



TRANE®

**Installation
Operation
Maintenance**

CG-SVX02B-EN

Library	Service Literature
Product Section	Refrigeration
Product	Hermetic Scroll Liquid Chillers, Air Cooled
Model	CG
Literature Type	Installation, Operation & Maintenance
Sequence	02B
Date	January 2005
File No.	SV-RF-CG-SVX02B-EN 105
Supersedes	CG-SVX02A-EN 403

**IntelliPak™
Air-Cooled Cold Generator**

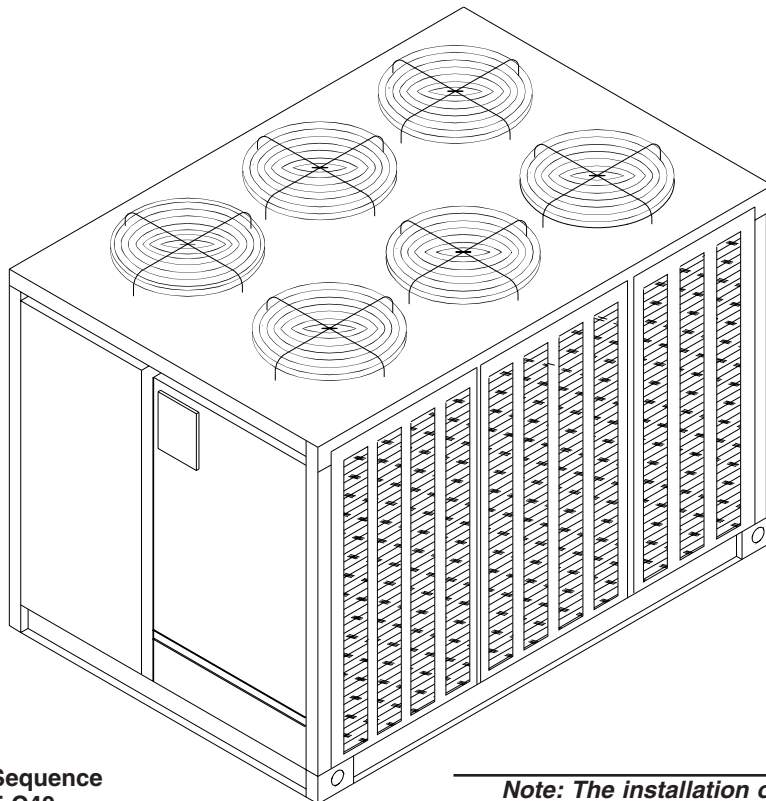

- Models**
 "K" and Later Design Sequence
- | | |
|----------|----------|
| CGAF-C20 | CGAF-C40 |
| CGAF-C25 | CGAF-C50 |
| CGAF-C30 | CGAF-C60 |

With 3-D™ Scroll Compressors

Note: The installation of this equipment must comply with all National, State and Local Codes.

Trane has a policy of continuous product and product data improvement and reserves the right to change design and specifications without notice. Only qualified technicians should perform the installation and servicing of equipment referred to in this publication.

About the Manual

Literature Change History

CG-SVX02B-EN (November 2004)

First issue of manual; provides Installation, Operation, and Maintenance instructions for “K” and later design sequence on CGAF 20 through 60 Ton air cooled Cold Generators.

Overview of Manual

Note: One copy of this document ships inside the control panel of each unit and is customer property. It must be retained by the unit's maintenance personnel.

This booklet describes proper installation, operation, and maintenance procedures for air cooled systems. By carefully reviewing the information within this manual and follow-

ing the instructions, the risk of improper operation and/or component damage will be minimized.

It is important that periodic maintenance be performed to help assure trouble free operation. A maintenance schedule is provided at the end of this manual. Should equipment failure occur, contact a qualified service organization with qualified, experienced HVAC technicians to properly diagnose and repair this equipment.

Note: The procedures discussed in this manual should only be performed by qualified, experienced HVAC technicians. Do Not release refrigerant to the atmosphere! If adding or removing refrigerant is required, the service technician must comply with all federal, state, and local laws.

Table of Contents

About the Manual

Literature Change History	2
Overview of Manual	2

General Information

Model Number Description	4
Unit Nameplate	4
Evaporator Barrel Nameplate	4
Compressor Nameplate	4
Hazard Identification	4
Unit Description	5
Input Devices & System Functions	5
Unit Component “Layout” and “Shipwith” Locations	8
Module Mounting Locations	9

Installation

Unit Inspection	10
Unit Clearances	10
Unit Dimensions & Weight Information	10
Foundation	10
Rigging	19
Unit Isolation	19
Leveling the Unit	19
Shipping Fasteners	22
General Unit Requirements	23
Chilled Water Piping Requirements	23
Main Electrical Power Requirements	23
Field Installed Control Wiring Requirements	23
Low Voltage Wiring (AC & DC)	23
Chilled Water Piping	23
Chilled Water Access Holes	24
Final Water Piping Connections	26
Freeze Protection from Ambient Contitions	26
Field Installed Power Wiring	28

Disconnect Switch External Handle	28
Main Unit Power Wiring	28
Power Wire Sizing and Protection Device Equations ...	30
Field Installed Control Wiring	32
Controls Using 115 VAC	32
Controls using 24 VAC	32
Controls using DC Analog Input/Outputs	32
Controls using DC Communication Links	33
Ice Building Control Option	33

System Pre-Start Procedures

Voltage Imbalance	38
Electrical Phasing	39

System Start-Up

Sequence of Operation	40
Chilled Water Circulating Pump	44
Ethylene Glycol Adjustment Factor	44
Verifying Proper Fan Rotation	47
Compressor Start-Up	47
Compressor Crankcase Heaters	51
Low Ambient Damper Adjustment	51
Final System Setup	51

Service & Maintenance

Compressor Operational Sounds	53
Scroll Compressor Replacement	53
Fuse Replacement Data	54
Monthly Maintenance	55
Coil Cleaning	56
Annual Maintenance	57
Final Process	57

Index	59
-------------	----

General Information

Model Number Description

All Trane products are identified by a multiple-character model number that precisely identifies a particular type of unit. An explanation of the alphanumeric identification code is provided below. Its use will enable the owner/operator, installing contractors, and service engineers to define the op-

eration, specific components, and other options for any specific unit.

When ordering replacement parts or requesting service, be sure to refer to the specific model number, serial number, and DL number (if applicable) stamped on the unit nameplate.

Sample Model Number: CGAF - C30 4 A A B 0 D etc.
Digit Number: 1,2,3,4 5,6,7 8 9 10 11 12 13 +

Digit 1,2 - Unit Function
CG = Cold Generator

Digit 9 - Heating Capacity
A = Standard

Digit 13, etc. Miscellaneous

A = Communications Interface (TCI)
B = No Unit Heat Tape (50 Hz Units Only)
C = Compressor Current Sensing (CSM)
D = Non-Fused Unit-Mounted Disconnect
E = *Unit Isolators - Neoprene P/S
F = *Unit Isolators - Spring P/S
G = Superheat / Subcooling
H = Hot Gas Bypass
J = Generic BAS Module 0-5 VDC Input, Binary O.P
L = LonTalk® Communication Interface Module
K = Stock Unit
L = LonTalk® Communication Interface Module
M = *Remote Human Interface
N = Generic BAS Module 0-10 VDC Analog Output
P = Remote Setpoint Potentiometer P/S
Q = *Zone Sensor (Chilled Solution Reset) P/S
S = Special
V = Copper Fin Condenser Coil
W = **Electronic Low Ambient Dampers P/S
Y = *Inter-Processor Comm Bridge (IPCB)
9 = Packed Stock Unit
* = Field Installed Options
** = Factory or Field Installed Option
*** Available on Pack Stock Units

Digit 3 - Unit Type
A = Air-Cooled Condenser

Digit 10 - Design Sequence
H = Brazed Plate Chiller

Digit 4 - Development Sequence
F = Sixth

Digit 11 - Leaving Water Setpoint

A = 40 - 50 F w/o Ice Machine
B = 30 - 39 F w/o Ice Machine
D = 51 - 65 F w/o Ice Machine
E = 20 - 29 F w/o Ice Machine
1 = 40 - 50 F w Ice Machine
2 = 30 - 39 F w Ice Machine
3 = 51 - 65 F w Ice Machine
4 = 20 - 29 F w Ice Machine
S = Special

Digit 5,6,7 - Nominal Capacity

C20 = 20 Tons
C25 = 25 Tons
C30 = 30 Tons
C40 = 40 Tons
C50 = 50 Tons
C60 = 60 Tons

Digit 8 - Power Supply

E = 200/60/3 P/S***
F = 230/60/3
4 = 460/60/3 P/S***
5 = 575/50/3
9 = 380/50/3
D = 415/50/3
S = Special

Digit 12 - Agency Approval

0 = None
1 = UL/CSA

Unit Nameplate

One Mylar unit nameplate is located on the outside upper right corner of the control panel door. It includes the unit model number, serial number, electrical characteristics, weight, refrigerant charge, as well as other pertinent unit data. A small metal nameplate with the Model Number, Serial Number, and Unit Weight is located just above the Mylar nameplate, and a third nameplate is located on the inside of the control panel door.

When ordering replacement parts or requesting service, be sure to refer to the specific model number, serial number, and DL number (if applicable) stamped on the unit nameplate.

Evaporator Nameplate

The nameplate is located on the opposite side of the water connections. The word "Nameplate" is stenciled on the insulation above the nameplate. To view the nameplate, remove the tape over the area and spread the insulation. Retape the insulation after viewing.

Compressor Nameplate

The nameplate for the "Scroll" compressors are located on the compressor lower housing.

Hazard Identification



WARNING— Indicates a potentially hazardous situation which, if not avoided, could result in death or serious injury.



CAUTION – Indicates a potentially hazardous situation which, if not avoided, may result in minor or moderate injury. It may also be used to alert against unsafe practices.

CAUTION – Indicates a situation that may result in equipment or property-damage-only accidents.

Echelon, LON, LONWORKS, LonBuilder, NodeBuilder, LonManager, LonTalk, LonUsers, Neuron, 3120, 3150, the Echelon logo, and the LonUsers logo are trademarks of Echelon Corporation registered in the United States and other countries. LonLink, LonResponse, LonSupport, LonMaker, and LonPoint are trademarks of Echelon Corporation.

General Information

Unit Description

Before shipment, each unit is leak tested, dehydrated, charged with refrigerant and compressor oil, and run tested for proper control operation.

Each unit is equipped with manifolded scroll compressors. Each manifolded set of compressors is piped in parallel and utilizes a passive oil management system to maintain proper compressor oil level.

The condenser coils are aluminum fin, mechanically bonded to copper tubing. Copper-fin coils are optional. Louvered condenser grilles for coil protection are standard.

Direct-drive, vertical discharge condenser fans are provided with built-in thermal overload protection.

For “Ship with” items, refer to the Unit Component “Layout” and “Ship with” Locations illustration.

If low ambient operation is required, low ambient dampers are available as a field or factory installed option.

The evaporators used in each air-cooled cold generator are of brazed plate construction. Each evaporator is fully insulated. Entering and leaving temperatures of the chilled solution are measured by sensors located on the evaporator.

A liquid line solenoid valve, filter drier, sight glass, thermostatic expansion valve, and service valves (liquid and discharge) are provided on each circuit.

Standard controls for these units is a microelectronics control system that consists of a network of modules referred to collectively as Unit Control Modules (UCM). The acronym UCM is used extensively throughout this document when referring to the control system network.

These modules, through Proportional/Integral control algorithms, perform specific unit functions that governs unit operation in response to chilled water temperature leaving the evaporator. The stages of capacity control for these units is achieved by starting and stopping the compressors.

The modules are mounted in the control panel and are factory wired to their respective internal components. They receive and interpret information from other unit modules, sensors, remote panels, and customer binary contacts to satisfy the applicable request for cooling. Refer to the following discussion for an explanation of each module function.

Human Interface Module (HI - Standard) (1U65 = Local, 6U66 = Remote)

The Human Interface module enables the operator to adjust the operating parameters for the unit using its 16 key keypad. The 2 line, 40 character LCD screen provides status information for the various unit functions as well as menus for the operator to set or modify the operating parameters.

Cold Generator Module (1U48) (CGM - Standard)

The Cold Generator Module (CGM) responds to cooling requests by energizing the proper unit components based on information received from other unit modules, sensors, remote panels, and customer supplied binary inputs. It initiates unit operation based on that information.

Compressor Module (1U44) (MCM)

The Compressor module, upon receiving a request for mechanical cooling, energizes the appropriate compressors and condenser fans. It monitors the compressor operation through feedback information it receives from various protection devices. It also provides heat tape output control for heat exchanger protection.

Interprocessor Communications Board (1U55) (IPCB - Optional - used with Optional Remote Human Interface)

The Interprocessor Communication Board expands communications from the unit's UCM network to a Remote Human Interface Panel. DIP switch settings on the IPCB module for this application should be; Switches 1 and 2 “Off”, Switch 3 “On”.

Trane Communications Interface Module (1U54) (TCI - Optional - used with Trane ICS™ Systems)

The Trane Communication Interface module expands communications from the unit's UCM network to a Trane Tracer 100™ or a Tracer Summit™ system and allows external setpoint adjustment and monitoring of status and diagnostics.

DIP Switch settings on the TCI module for these applications should be: Switches 1, 2, and 3 are “Off”

Generic Building Automation System Module (1U51 = GBAS 0-5V, 1U98 = GBAS 0-10V)

Optional - used with Non-Trane Building Control System)
The Generic Building Automation System (GBAS) module allows a non-Trane building control system to communicate with the unit and accepts external setpoints in form of analog inputs (0 - 5 DCV or 0 - 10 DCV depending on the module selected) and a binary Input for demand limit. Five (5) binary outputs are available on 0 - 5 DCV modules. One (1) binary output and four (4) analog outputs are available on the 0 - 10 DCV modules. Refer to the “Field Installed Control Wiring” section for the control wiring to the GBAS module and the various desired setpoints with the corresponding DC voltage inputs.

Lontalk Communication Interface Module (1U54) (LCI Optional - used on units with Trane ICS™ or 3rd party Building Automation Systems)

The LonTalk Communication Interface module expands communications from the unit's UCM network to a Trane Tracer Summit™ or a 3rd party building automation system, that utilizes LonTalk, and allows external setpoint and configuration adjustment and monitoring of status and diagnostics.

Current Sensing Module (1U90) (CSM - Optional)

Current transformers located around two (2) of the main power leads for each compressor monitors the running current during compressor operation. The information is sent to the CGM and can be accessed through the “Compressor Status” submenu displayed at the Human Interface Module.

Superheat & Subcooling Module (1U91) (SSM - Optional)

Monitors the system operating superheat and subcooling through the use of pressure transducers, liquid line, and suction line temperature sensors. The information is sent to the SSM and can be accessed through the “Compressor Status” submenu displayed at the Human Interface Module.

Input Devices & System Functions

The descriptions of the following basic Input Devices used within the UCM network are to acquaint the operator with their function as they interface with the various modules. Refer to the unit's electrical schematic for the specific module connections.

General Information

Lead/Lag (Standard)

When Lead-Lag is enabled, for each capacity add request, the CGM will begin sequencing the compressors “On” that have:

- a. the least number of starts; or,
- b. the least run time (if number of starts are equal)

At each capacity subtract request, the CGM will begin sequencing the compressors “Off” that have:

- a. the most run time; or,
- b. the least number of starts (if more than one compressor has the same run time)

If a compressor is locked out for any reason when a capacity add request occurs, the next available compressor which meets the specified criteria will be started.

If a compressor can not be turned “Off” due to the minimum “On Time”, the next compressor which meets the specified criteria will be turned “Off”.

On dual circuit units, as the first two capacity add requests are initiated, one compressor on each circuit will start before any additional compressors on any circuit is started. When staging down from three compressor stages to two compressor stages, the CGM will turn the compressors “Off” on the circuit that has the most compressors operating.

With Lead/Lag enabled, HGBP operation (if applicable) will be bypassed and the system will go directly into pumpdown when the last subtract command is initiated.

When the UCM is powered up (after a power loss), or any time the compressor’s start time and run time are equal, the lead compressor for single circuit units (20 through 30 Tons), will be the first “On” and the lag compressor will be the first “Off”. For dual circuit units (40 through 60 Tons), the “On” sequence will be A-C-B-D and the “Off” sequence will be D-B-C-A.

Loss of Charge/Flow (Refrigerant) Control

Is accomplished by Loss of Charge Cutout (LCC) switch(es), located on the suction line(s) near the scroll compressor(s). The LCC are connected to the SCM or MCM Low Pressure Cutout (LPC) binary input.

The LCC contacts are designed to open if the suction pressure approaches 7 ± 4 psig. If the LCC opens after a compressor has started, all compressors operating on that circuit will be turned off immediately and will remain off for a minimum of three minutes.

The LCC contacts are designed to close when the suction pressure exceeds 22 ± 4 psig. If the LCC is open when a compressor is requested to start, none of the compressors on that circuit will be allowed to operate. They are locked out and a manual reset diagnostic is initiated. If the LCC opens four consecutive times, during the initial three minutes of compressor operation on a circuit, the compressors

on that circuit will be locked out and a manual reset diagnostic is initiated.

Evaporator Freeze Protection

Is accomplished by Freeze Protection Cutout (FPC) switch(es), located on the suction line(s) near the scroll compressor(s).

The FPC are connected to the SCM or MCM Low Pressure Cutout (LPC) binary input, in series with the LCC switch(es.) The FPC switch is used to prevent the refrigerant from becoming cold enough to cause the chilled solution in the Evaporator to freeze. This pressure switch is typically set to trip at a higher refrigerant pressure, typically 20 to 45 PSIG depending on the selected leaving water setpoint range of the unit.

If the FPC opens after a compressor has started, all compressors operating on that circuit will be turned off immediately and will remain off for a minimum of three minutes.

If the FPC is open when a compressor is requested to start, none of the compressors on that circuit will be allowed to operate. They are locked out and a manual reset diagnostic is initiated.

If the FPC opens four consecutive times, during the initial three minutes of compressor operation on a circuit, the compressors on that circuit will be locked out and a manual reset diagnostic is initiated.

Saturated Condenser Temperature Sensors (Standard)

Are analog input devices mounted inside a temperature well located on a condenser tube bend. They monitor the saturated refrigerant temperature inside the condenser coil and are connected to the compressor module (MCM). As the saturated refrigerant temperature varies due to operating conditions, the condenser fans are cycled “On” or “Off” as required to maintain acceptable operating pressures.

Head Pressure Control (Standard)

Is generally achieved by staging condenser fans on if the Saturated Condensing Temperature (SCT) rises above the Saturated Condensing Temperature Control Band Upper Limit (SCTUL) and staged off if the SCT falls below the Saturated Condensing Temperature Control Band Low Limit (SCTLL), in an effort to maintain the SCT within this fixed temperature range.

For 20 and 40 ton units, two outputs (A and C) per circuit are controlled. For 25, 30, 50 and 60 ton units, three outputs (A, B and C) per circuit are controlled. Each output controls a condenser fan motor contactor. Output C will energize on initial call for fan staging, and will remain energized as long as a compressor on that circuit is on. The third condenser fan motor associated with Output C will be located under the low ambient damper, if that option is installed.

Condenser Fan Output Control (MCM relays and fan motor contactors)

Unit Tonnage	Circuit	Output A		Output B		Output C*		No. of Stages
		MCM Relay	Fan Contactor	MCM Relay	Fan Contactor	MCM Relay	Fan Contactor	
20	1	K1	1K8	na	na	K7	1K7	2
25	1	K1	1K8	K2	1K12	K7	1K7	3
30	1	K1	1K8	K2	1K12	K7	1K7	4
40	1	K1	1K8	na	na	K7	1K7	2
	2	K5	1K10	na	na	K8	1K9	2
50	1	K1	1K8	K2	1K12	K7	1K7	3
	2	K5	1K10	K6	1K13	K8	1K9	3
60	1	K1	1K8	K2	1K12	K7	1K7	3
	2	K5	1K10	K6	1K13	K8	1K9	3

* Output under the Low Ambient Damper, if installed.

For 25, 30, 50 and 60 ton units, the Saturated Condenser OA Temp Suppression Setpoint (SCTOATSS) is a Human Interface settable parameter (default: 40°F, range: 30 - 50°F, Disabled: above 50°F) which determines how many condenser fan outputs will turn on.

Upon first compressor start on a circuit, all condenser fans remain off until the SCT rises above the control band lower limit. On 25, 30, 50 and 60 ton units, if the Outdoor Air Temperature (OAT) is greater than or equal to the SCTOATSS, or the SCTOATSS Function is disabled, all condenser fan outputs will be energized. If the OAT is less than the SCTOATSS, only Outputs B and C are energized. On 20 and 40 ton units, all condenser fan outputs will be energized.

When one or more condenser fan outputs are energized:

If the SCT rises above the SCTUL, for 20 and 40 ton units, all condenser fan outputs are energized. For 25, 30, 50 and 60 ton units, if the OAT is less than the SCTOATSS only one condenser fan stage will be added. If the OAT is greater than or equal to SCTOATSS, or the SCTOATSS Function is disabled, all condenser fan stages will be energized.

If the SCT falls below the SCTLL, for 20 and 40 ton units, if both Outputs A and C are on, then Output A is de-energized. If only Output C was on, it remains on. For 25, 50 and 60 ton units, if both Outputs A and B are on, Output A is de-energized. ^(See Note 1) If only Output B is on, Output B is de-energized. ^(See Note 2) For 30 ton units, if both Outputs A and B are on, Output A is de-energized. ^(see Note 3) If only Output B is on, Output B is de-energized and Output A is energized. ^(see Note 4) If only Output A is on, Output A is de-energized. ^(see Note 2)

If the SCT rises above the Saturated Condensing Temperature Efficiency Check Point (SCTECP), for 20 and 40 ton units, no outputs are changed. For 25, 50 and 60 ton units, if the OAT is less than the SCTOATSS, no outputs are changed. If the OAT is greater than the SCTOATSS, or disabled, if Output A and Output B are off, then Output B is energized. If Output B is on and Output A is off, no outputs are changed. For 30 ton units, if the OAT is less than the SCTOATSS, no outputs are changed. If the OAT is greater than the SCTOATSS, or disabled, if Output A and Output B are off, Output A is de-energized. If Output A is on and Output B is off, Output B is energized and Output A is de-energized. If Output B is on and Output A is off, no outputs are changed.

Notes:

1. If the SCT remains below the SCTLL for 30 seconds after the stage change, then Output B will be de-energized. At this time, only the fan (under the low ambient damper) controlled by Output C will be on.
2. At this time, only the fan (under the low ambient damper) controlled by Output C will be on.
3. If the SCT remains below the SCTLL for 30 seconds after the stage change, then Output A will be energized and Output B will be de-energized. If the SCT remains below the SCTLL for an additional 30 seconds after the stage change, then Output A will be de-energized. At this time, only the fan (under the low ambient damper) controlled by Output C will be on.
4. If the Sat Cond. Temp. remains below the SCTLL for an additional 30 seconds after the stage change, then Output A will be de-energized. At this time, only the fan (under the low ambient damper) controlled by Output C will be on.

To prevent rapid fan cycling, minimum condenser fan stage on and off time is 5.2 seconds, except when all compressor stages on a circuit are de-energized for any reason, the condenser fan stages on that circuit

General Information

are de-energized immediately without regard to the condenser fan minimum on time. Also, if four fan stage changes occur within a ten minute period, then SCT is controlled to SCTLL minus "Saturated Condenser Temp Control Band Temporary Low Limit Suppression" for a period of one hour.

In a low ambient condition, adding or subtracting a full fan stage provides excess capacity. To provide head pressure control in low ambient conditions, the UCM controls SCT to the "Saturated Condensing Temperature Low Ambient Control Point" by modulating the capacity of a dedicated condenser fan stage between 0 and 100% via the Low Ambient Fan Control Actuator output

Normally, the head pressure control allows unit operation down to 30°F. With the addition of a low ambient damper, This feature allows for low ambient compressor operation down to 0°F.

The low ambient control algorithm is active on all units, regardless of whether the unit is configured as having low ambient damper option.

High Pressure Controls (Standard)

High Pressure controls are located on the discharge lines near the scroll compressors. They are designed to open when the discharge pressure approaches the unit specific pressure setting. The controls reset automatically when the discharge pressure decreases to the unit specific pressure setting. However, the compressors on that circuit are locked out and a manual reset diagnostic is initiated.

Low Ambient Control (Optional)

The low ambient modulating output on the compressor module is functional on all units with or without the low ambient option.

Anytime the unit is powered-on, this output is operational, regardless if the compressors are ON or OFF. Once the condenser fan operation is started, the condenser fan located under this damper will remain ON until all compressors on that circuit are turned OFF. These dampers will modulate to maintain the saturated condensing temperature to the "Saturated Condensing Temperature Control Point" and the "Low Ambient Control Deadband" which are located under the Human Interface setup screens for Head Pressure Control.

Status/Alarm Output (Standard)

Is an internal function within the CGM control module that provides;

- a. diagnostic signals to the Human Interface Alarm LED.
- b. control of the binary Alarm output.
- c. control of the binary outputs on the GBAS module to inform the customer of the operational status and/or diagnostic conditions.

Compressor Circuit Breakers (Standard)

The Scroll Compressors are protected by circuit breakers which interrupt the power supply to the compressors if the current exceeds the breakers "must trip" value and opens a set of auxiliary contacts in the control circuit.

When the Compressor Module (MCM) detects the open auxiliary compressor contacts, it turns any operating compressor(s) on that circuit "Off", locks out all compressor operation for that circuit, and initiates a manual reset diagnostic.

General Information

Compressor Motor Winding Thermostats (Standard)

A thermostat is embedded in the motor windings of each Scroll compressor. Each thermostat is designed to open if the motor windings exceeds approximately 221°F. The thermostat will reset automatically when the winding temperature decreases to approximately 181°F. Rapid cycling, loss of charge, abnormally high suction temperatures, or the compressor running backwards could cause the thermostat to open. During a request for compressor operation, if the Compressor Module detects a problem outside of its normal parameters, it turns any operating compressor(s) on that circuit "Off", locks out all compressor operation for that circuit, and initiates a manual reset diagnostic.

Low Ambient Compressor Lockout (Standard)

When low ambient compressor lockout is enabled, the compressors are not allowed to operate if the temperature of the outside air falls below the lockout setpoint. Compressor operation is enabled when the temperature rises 5°F above the lockout setpoint. The setpoints and enable/disable option is programmable at the Human Interface inside the unit control panel. The default setting is 30°F.

Short Cycle Protection (Standard)

If compressor operation is interrupted by a loss of power or by a manual reset diagnostic, a minimum of one minute must elapse before the affected compressor(s) will be allowed to restart for "Process" applications. A minimum of three minutes must elapse before the affected compressor(s) will be allowed to restart for "Comfort Cooling" applications.

Hot Start (Load Limit) Control (Standard)

Each time the system is started and the control of the CGM transitions from "Loop Stabilization" to either "Process" or "Comfort Cooling", if the Leaving Solution Temperature (LST) is higher than the programmable Hot Start Load Limit Setpoint (HSLLS), the lag compressor on each circuit will be prevented from operating until the leaving solution temperature is lowered by 5°F below the HSLLS.

If the Hot Start Limit time interval elapses before the LST is 5°F below the HSLLS, the control will transition immediately into the Hot Operation mode.

Hot Operation mode is programmable to:

1. Do not limit capacity, initiate an informational diagnostic until the LST falls 5°F below the HSLLS.
2. Limit the capacity to 50 percent (one compressor per circuit), initiate an auto reset diagnostic until the LST falls 5° F below the HSLLS.
3. Turn "Off" and lockout all of the compressors and initiate a manual reset diagnostic.

Loss-of-Flow (Solution) Protection (Standard)

All units:

Compressors are allowed to operate once the pump is running and the flow switch input is closed. If the flow switch input opens during normal operation for longer than 6 seconds, the compressors and fans will stop. If the switch input is still open after 5 minutes, a auto-reset diagnostic (Evap Solution Flow Proving Switch) will be generated. Once this input is closed, the diagnostic will clear and the compressors will be allowed to resume operation. If the flow switch fails open or is not connected when the chiller starts up,

only the solution pump output will be energized. 5 minutes later, an auto-reset diagnostic (Evap Solution Flow Proving Switch) will be generated. Once the flow switch input closes, the chiller will operate normally.

If the chiller controls the pump (Chiller solution pump mode = AUTO):

If the pump is cycled off by the CGM or a power failure occurs, and the unit is re-started, the flow switch input must open and then close for proper operation. If the switch is stuck closed or shorted, the pump will start but compressors will not operate. Also, a manual resettable diagnostic (Evaporator Solution Flow Loss) will be generated. To reset the diagnostic, stop the pump and allow the flow switch to open, then reset at the Human Interface (see Programming Guide).

Note: There is a minimum "off" time of 60 seconds for the pump output. This "off" time is overridden if the flow switch opens.

If the chiller does not control the pump (Chiller solution pump mode = ON):

Do not bypass the flow switch input! If the flow switch input is bypassed, the unit will not have flow loss protection and equipment damage may result.

WARNING

Equipment Damage!

Do not bypass the flow switch input! If the flow switch input is bypassed, the unit will not have flow loss protection and equipment damage may result.

The flow switch input must be closed for compressor operation. If the flow switch input is open and a request for cooling is given, compressors will not start and a auto-reset diagnostic (Evap Solution Flow Proving Switch) will be generated after 5 minutes. Once this input is closed, the diagnostic will clear and the compressors will be allowed to operate.

Low Ambient Start (Standard)

Before first start of a compressor on a refrigerant circuit, the CGM Low Ambient LPC Bypass output is closed which bypasses the Freeze Protection Cutout (FPC) switch in the MCM Low Pressure Cutout (LPC) input circuit for a period of time that varies based on the prevailing ambient temperature. The relationship between this variable time period and the ambient temperature is linear from a maximum of 5 minutes at 0°F to a minimum of two minutes at 65°F. A fixed three minute bypass time is initiated each time a subsequent compressor is started on a refrigerant circuit. No additional compressors will be allowed to start within that circuit until the bypass time has expired.

Chiller Solution Pump Output Relay (Standard)

A Solution Pump binary output (Form C) relay is located on the CGM which may be used to control the chiller solution pump.

If the Chiller Solution Pump Mode, at the Human Interface Module, is set to "On", the Solution Pump will run continuously.

If the Chiller Solution Pump Mode, at the Human Interface Module, is set to Auto, the Solution Pump will be turned "Off":

General Information

1. when the unit is stopped (Unit Stop or External Auto/ Stop)
2. during the unit's Power On Delay Time
3. when the primary control states are:
 - Ice Rebuild Delay
 - Ice Building Complete

A Solution Pump "Off Delay" Time may be programmed to allow the Solution Pump to remain "On", for an adjustable period of time between 0.5 minutes and 10 minutes, at the time an "Off" state is requested. The Solution Pump will always run for this delay time when turning off except during an Emergency Stop condition. If an Emergency Stop is initiated, the Solution Pump is immediately turned "Off" (relay de-energized).

On units configured with pump mode 'Auto', a solution pump 'On Delay' of 60 seconds will be enforced after the pump turns off to allow the solution flow proving switch to open before the pump is allowed to start. If the flow switch opens, this delay will be over-riden and the pump will be allowed to start.

Low Ambient Pump Control (Standard)

A Low Ambient Pump "On" Control function (LAPC) allows the pump to run continuously if either the entering or leaving solution temperature falls below a programmable Low Ambient Pump Override Temperature (LAPT) Setpoint or if either the entering or leaving Solution temperature input failure occurs. An Auto Reset Diagnostic will be issued and remain as long as the condition exists.

If both entering and leaving solution temperatures rise above the Low Ambient Pump Override Temp Setpoint plus three degrees and either temperature has risen above the Active Leaving Solution Setpoint, the Auto Reset diagnostic is cleared and the pump is turned off.

This function will be disabled when an Emergency Stop request is initiated.

During service test operation, if a low ambient condition exists when the operator attempts to turn the pump "Off", a message will be displayed on the Human Interface Module advising that the pump cannot be turned off due to the low ambient condition.

Emergency Stop (Optional)

Is accomplished when a customer provided, field installed binary input device is connected to the CGM. The unit will immediately shut down when the contacts are opened. Emergency Stop is a top priority command that will override all other commands received by the UCM. A manual reset diagnostic will occur and an indication showing that the unit is shut down due to Emergency Stop will be displayed at the Human Interface Module.

External Auto/Stop (Optional)

The unit can be Stopped and Started by a remote customer provided field installed binary input device (such as a time clock) connected to the CGM. When the input is opened (Stop), the unit will stage the compressors and the solution pump "Off" in a normal manner and display "Off due to external stop" at the unit Human Interface. When the input is closed (Start), the unit will start and run normally.

The External Auto/Stop input operates in the same manner as the STOP/AUTO keys on the unit mounted Human Interface or the Remote Human Interface (RHI). However, the Stop key at the unit mounted Human Interface has priority over both the remote External Auto/Stop and the Remote Human Interface Auto/Stop.

Note: If the STOP key is pressed at the unit mounted Human Interface, no remote AUTO (Start) key will start the unit until the AUTO key is pressed at the unit mounted Human Interface.

A start (AUTO) command is allowed only if no overriding diagnostics or higher priority function is present.

Flow Switch Interlock (Standard)

While the factory provided field installed flow switch is wired to the CGM, if it opens for more than 6 continuous seconds when the pump is requested to be "On", compressor operation will be inhibited and if compressors are operating, they will be turned off. If the flow switch remains open for 5 continuous minutes an auto reset diagnostic will occur.

Chiller Heat Tape Control Output

Heat tape control for the chiller heat exchanger will be provided by the unit. If either the entering or leaving solution temperatures fall below the heat tape temperature setpoint, the heat tape relay on the MCM module will de-energize, turning the heat tape on. If either of these two sensors fail, the heat tape relay will de-energize, turning the heat tape on. The heat tape relay will energize, turning the heat tape off when 1) compressor operation is required, or 2) both EST and LST rise 3°F above the heat tape temperature.

Unit Component "Layout" and "Ship with" Locations

(60 Ton Unit Illustrated)

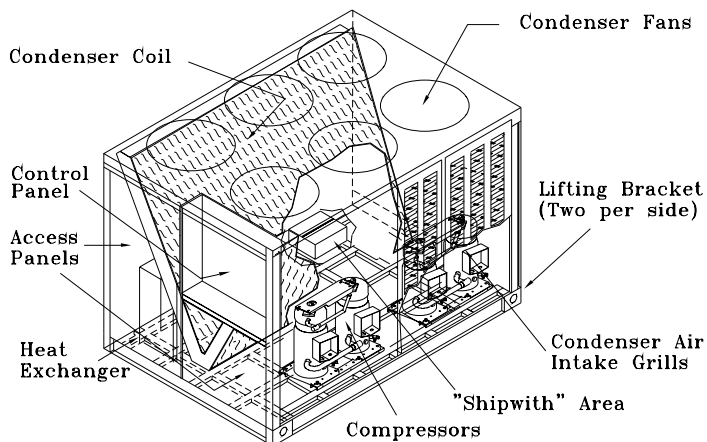

General Information

Module Mounting Locations & Screw Hole

20 - 30 Ton

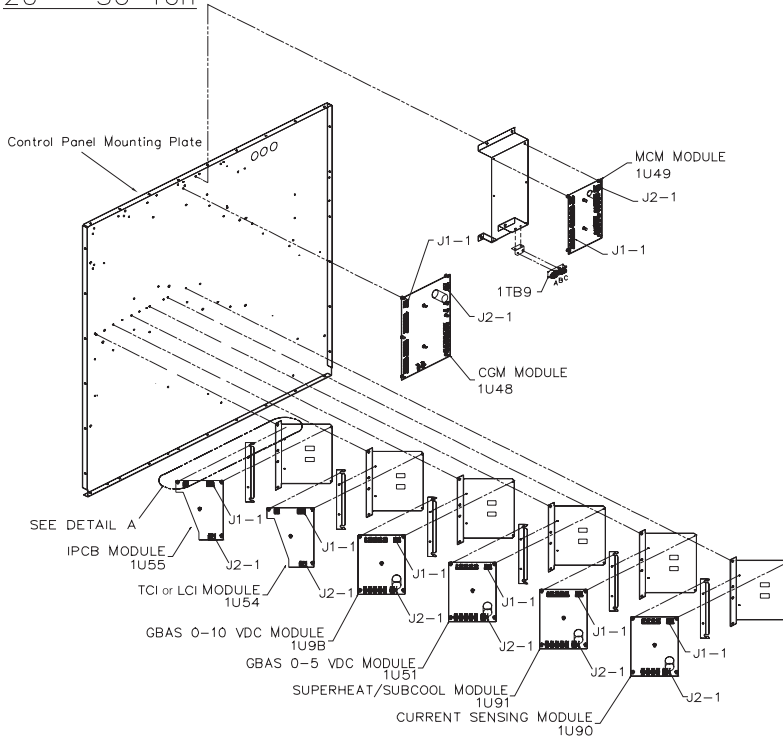

40 - 60 Ton

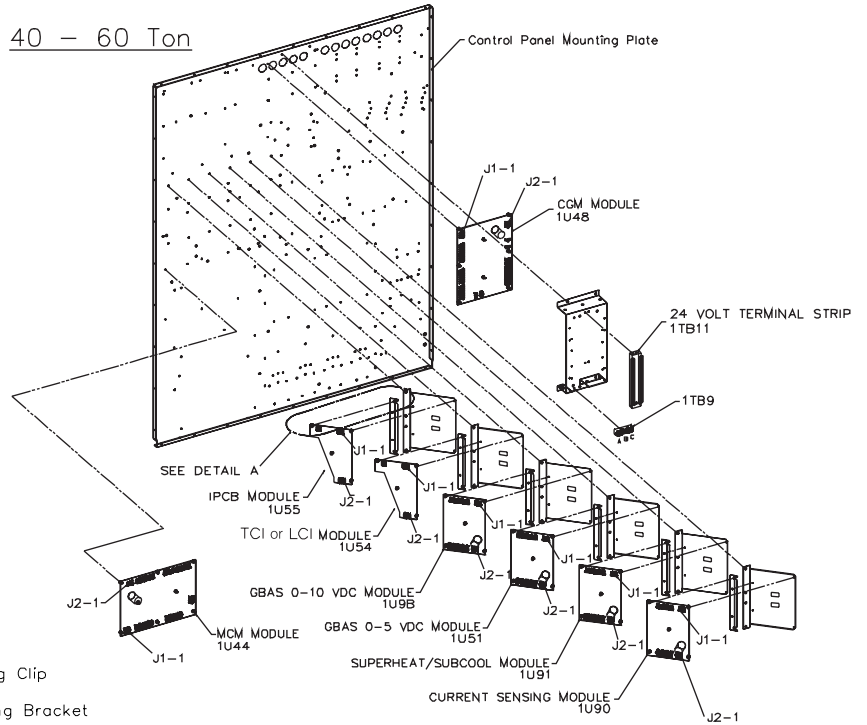

20 - 60 Ton

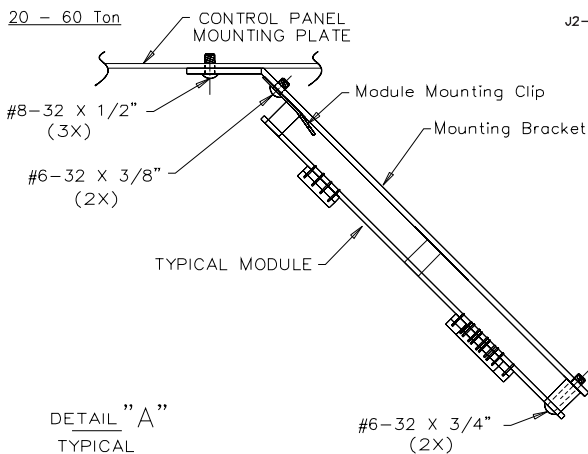

DETAIL "A"
TYPICAL

Installation

Unit Inspection

As soon as the unit arrives at the job site

- [] Verify that the nameplate data matches the data on the sales order and bill of lading (including electrical data).
- [] Verify that the power supply complies with the unit nameplate specifications.
- [] Visually inspect the exterior of the unit, including the roof, for signs of shipping damage.
- [] Check for material shortages. Refer to the Component Layout and Shipwith Location illustration.

If the job site inspection of the unit reveals damage or material shortages, file a claim with the carrier immediately. Specify the type and extent of the damage on the "bill of lading" before signing.

- [] Visually inspect the internal components for shipping damage as soon as possible after delivery and before it is stored. Do not walk on the sheet metal base pans.



WARNING **No Step Surface!**

Do not walk on the sheet metal drain pan. Walking on the drain pan could cause the supporting metal to collapse. Failure of the drain pan could result in death or serious injury.

Bridging between the unit's main supports may consist of multiple 2 by 12 boards or sheet metal grating.

- [] If concealed damage is discovered, notify the carrier's terminal of damage immediately by phone and by mail. Concealed damage must be reported within 15 days.

Request an immediate joint inspection of the damage by the carrier and the consignee. Do not remove damaged material from the receiving location. Take photos of the damage, if possible. The owner must provide reasonable evidence that the damage did not occur after delivery.

- [] Notify the appropriate Trane office before installing or repairing a damaged unit.

Unit Clearances

Figure 1 illustrates the minimum operating and service clearances for either a single, multiple, or pit application. These clearances are the minimum distances necessary to assure adequate serviceability, cataloged unit capacity, and peak operating efficiency.

Providing less than the recommended clearances may result in condenser coil starvation or recirculation of hot condenser air.

Locate the unit as close to the applicable system support equipment as possible to minimize refrigerant piping lengths.

Unit Dimensions & Weight Information

Overall unit dimensional data for each unit is illustrated in Figure 2.

A Center-of-Gravity illustration and the dimensional data is shown in Figure 3.

Table 1 lists the typical unit operating and point loading weights.

Foundation

If the unit is installed at ground level, elevate it above the snow line. Provide concrete footings at each support location or a slab foundation for support. Refer to Table 1 for the unit operating and point loading weights when constructing the footing foundation.

Anchor the unit to the footings or slab using hold down bolts or isolators. Isolators should be installed to minimize the transmission of vibrations into the building. Refer to the "Unit Isolation" section for spring or rubber isolator installation instructions.

For rooftop applications, ensure the roof is strong enough to support the unit. Refer to Table 1 for the unit operating weights.

Anchor the unit to the roof with hold-down bolts or isolators. Follow the instructions under "Unit Isolation" for proper isolator placement and installation.

Check with a roofing contractor for proper waterproofing procedures.

Figure 1

Typical Installation Clearances for Single, Multiple or Pit Applications

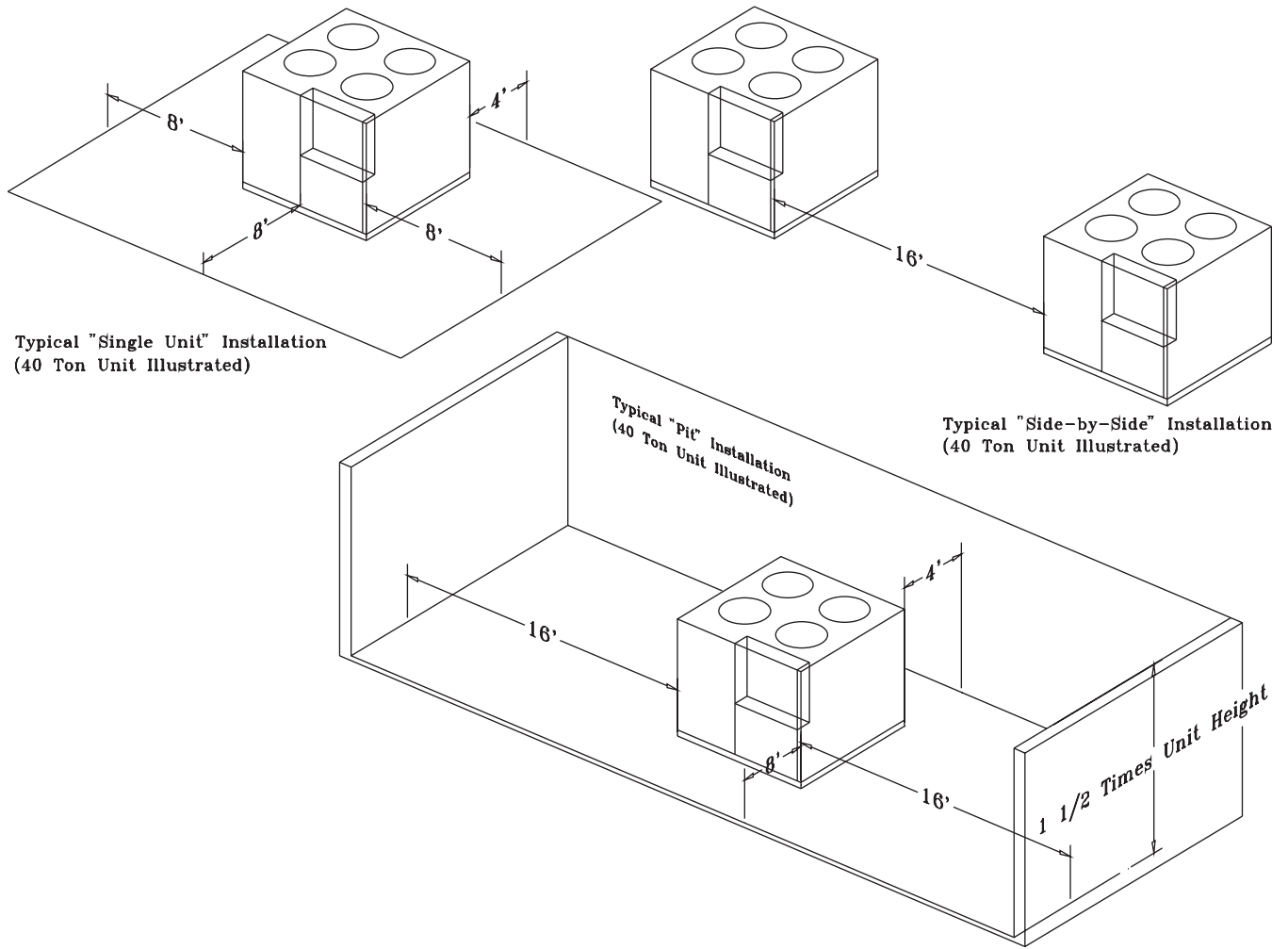

Figure 2
C20 Ton Unit Dimensional Data & Recommended Clearances

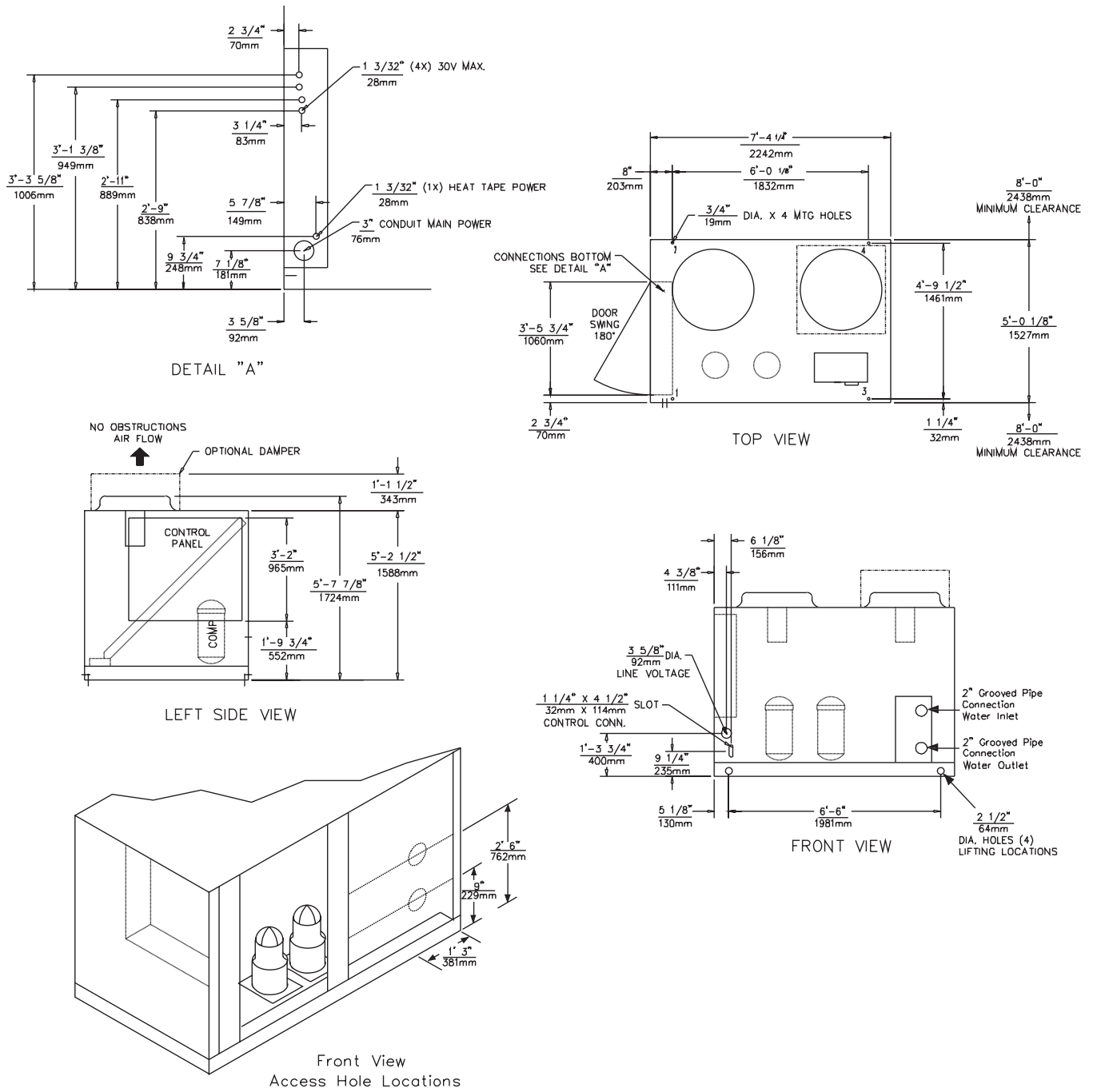

Figure 2
C25 Ton Unit Dimensional Data & Recommended Clearances

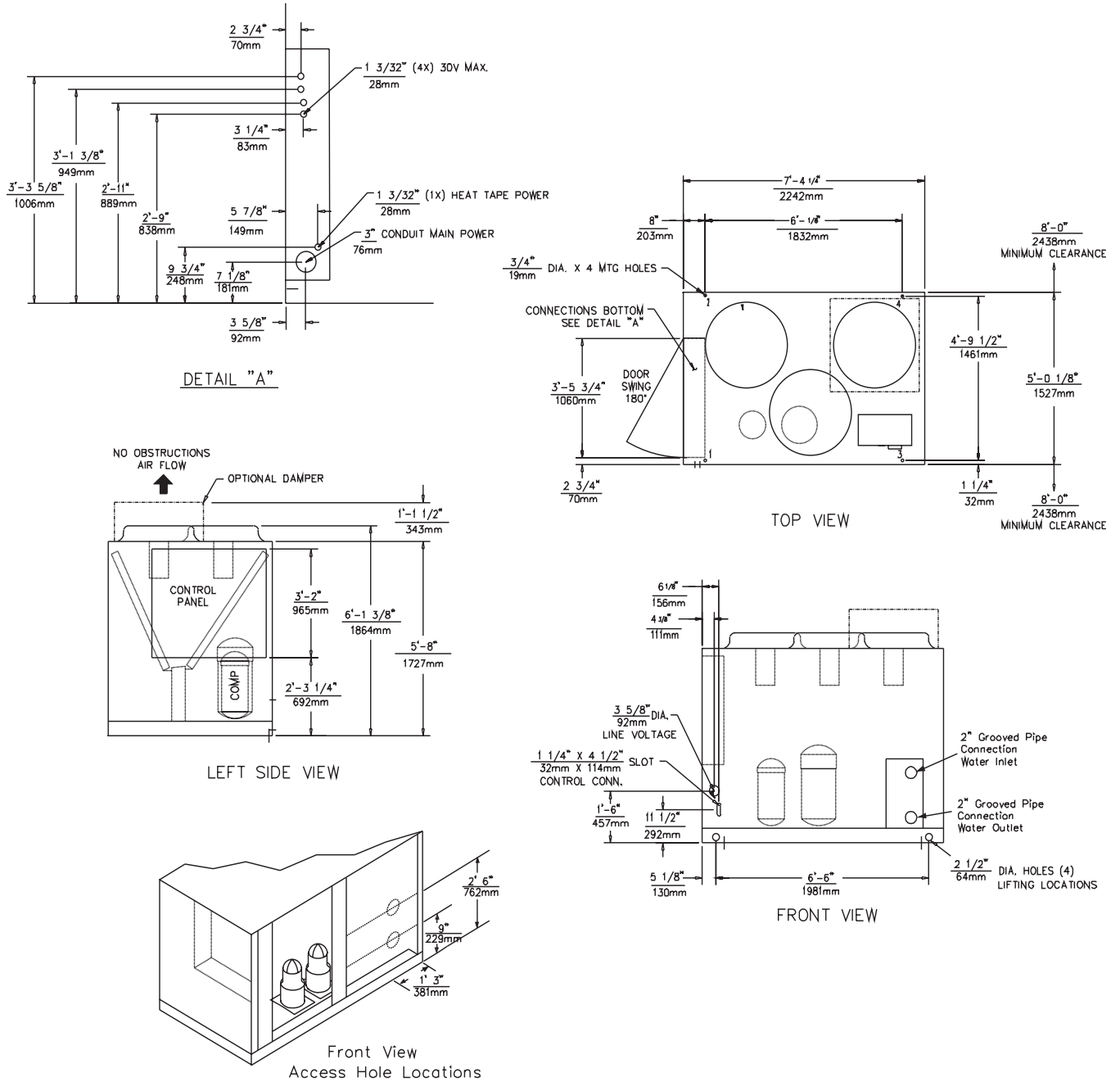

Figure 2
C30 Ton Unit Dimensional Data & Recommended Clearances

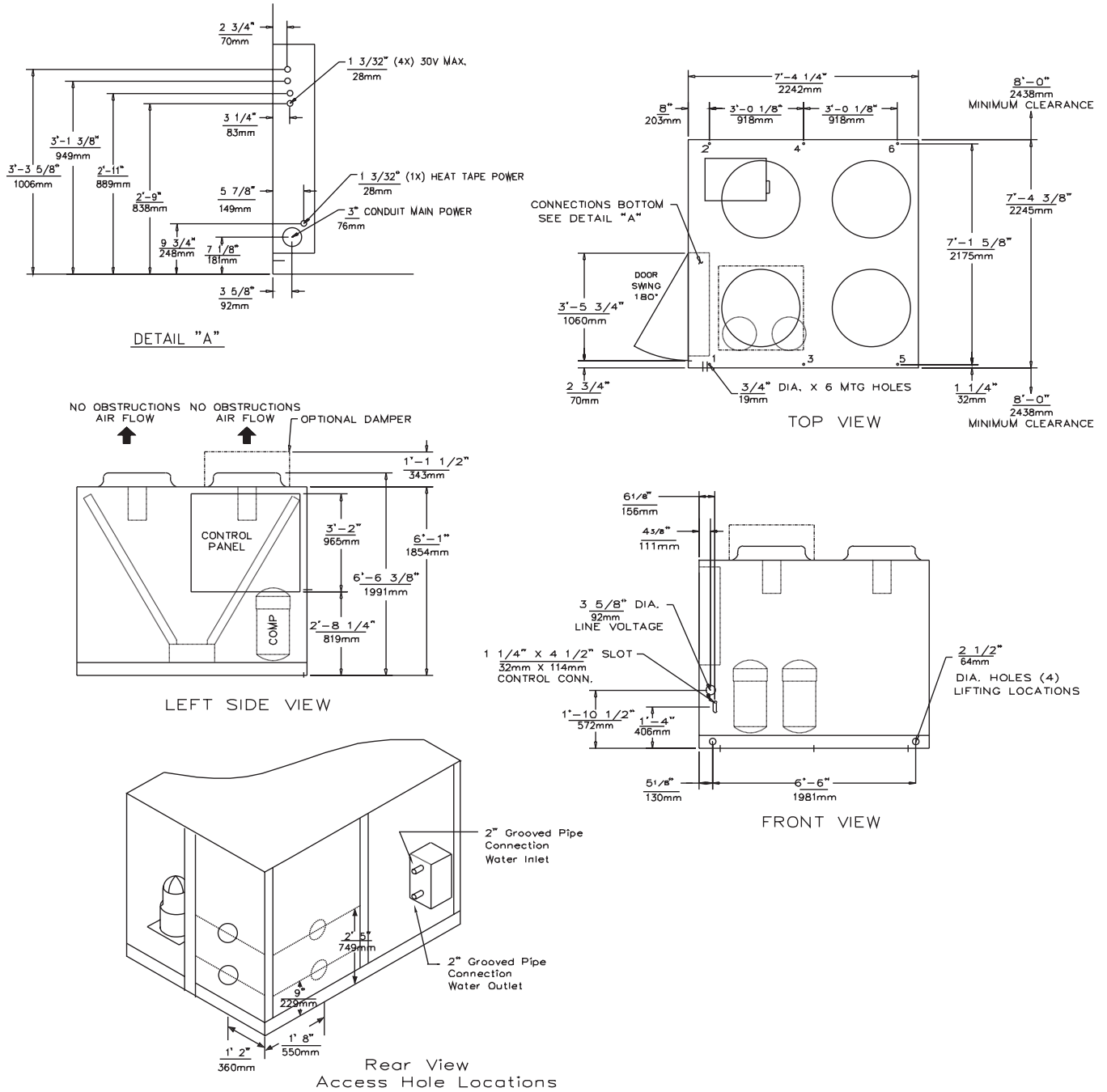

Figure 2
C40 Ton Unit Dimensional Data & Recommended Clearances

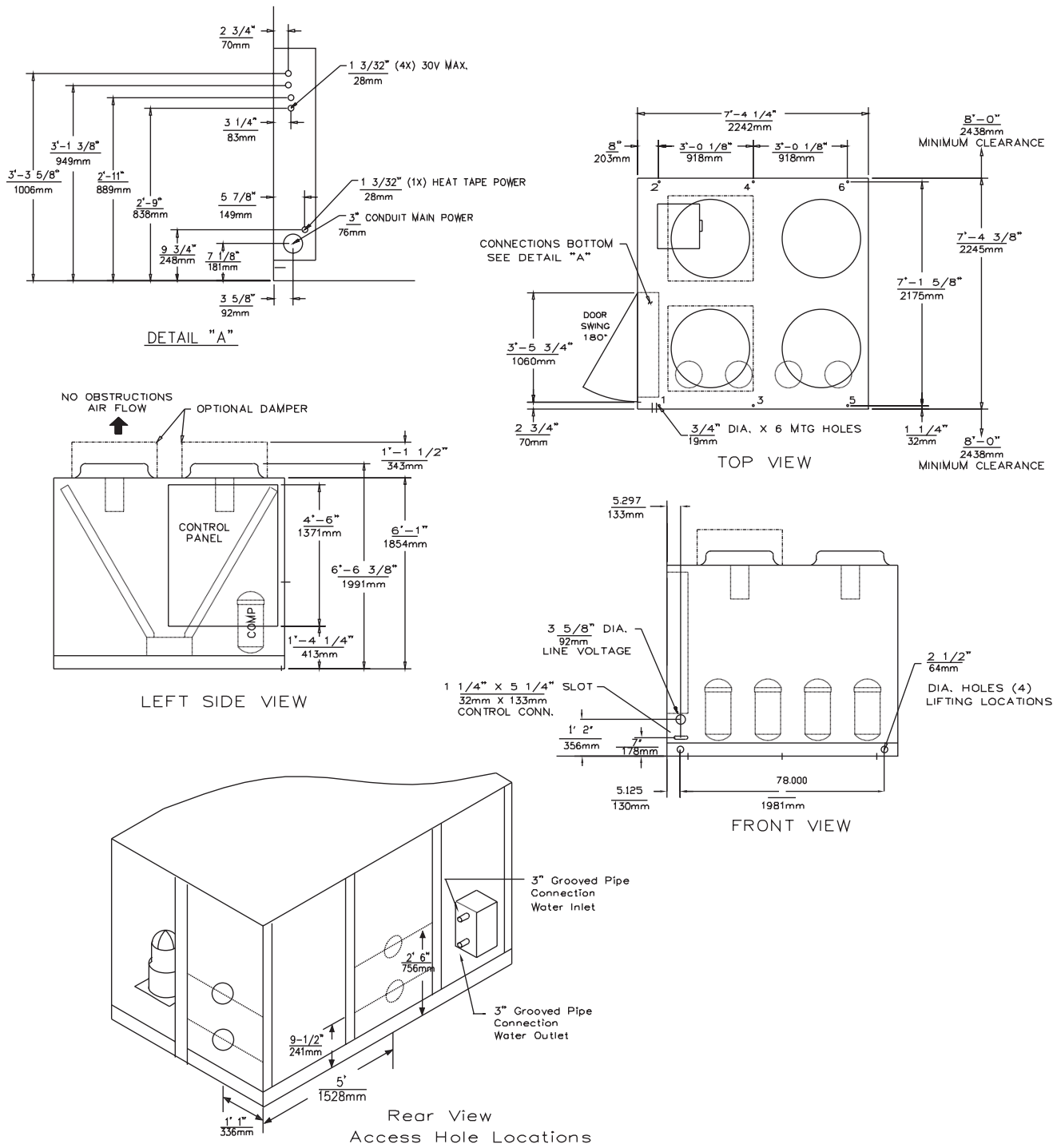

Figure 2
C50 Ton Unit Dimensional Data & Recommended Clearances

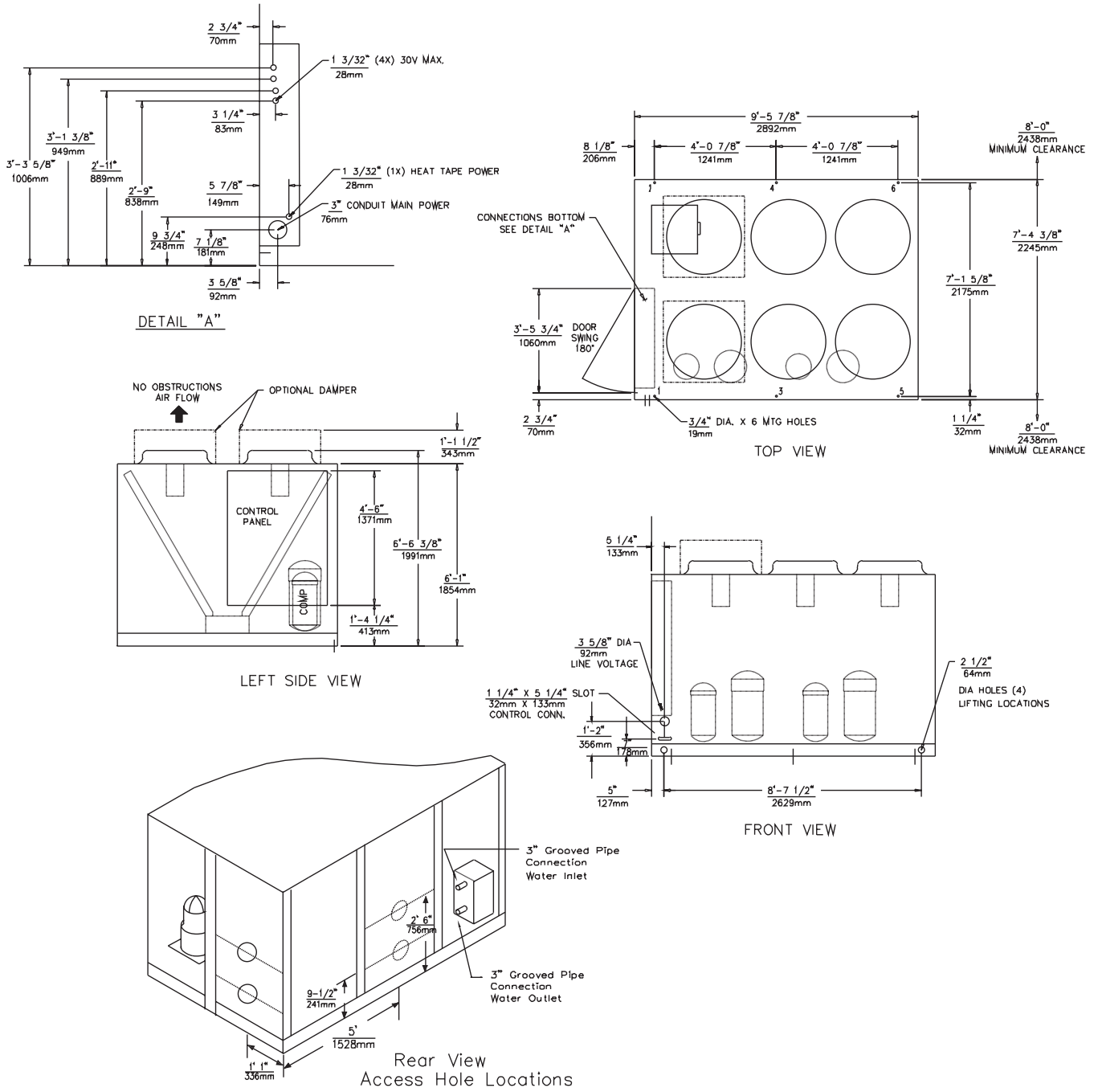
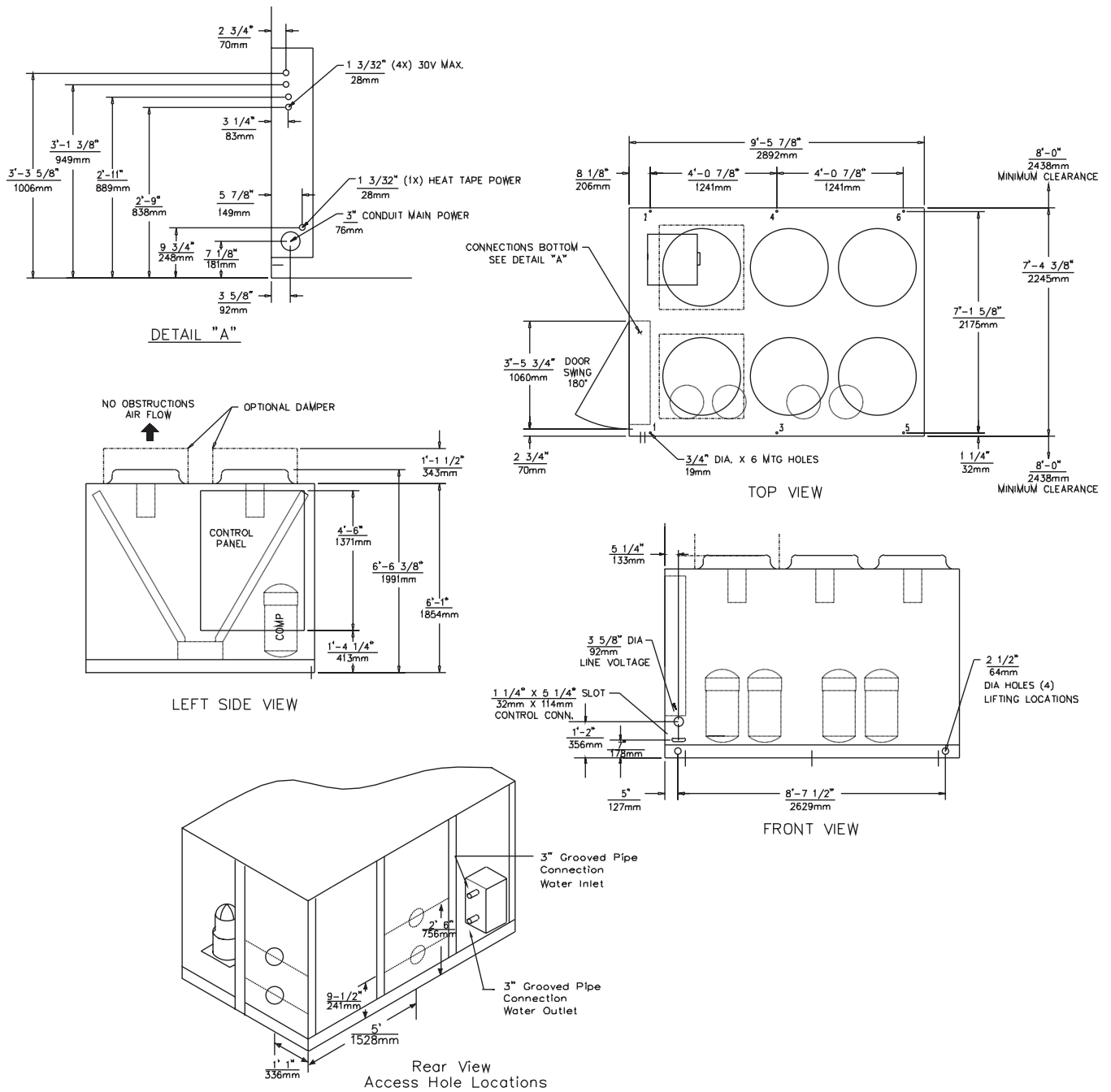

Figure 2
C60 Ton Unit Dimensional Data & Recommended Clearances



Installation

Table 1
Typical Unit Weights & Point Loading Data

Unit Size	Condenser Fin Mat'l.	Operating Weight	Operating Weight Distribution @ Unit Mounting Points					
			1	2	3	4	5	6
C20	Alum.	1870	595	470	470	335	—	—
	Copper	2085	690	475	490	430	—	—
C25	Alum.	2085	700	470	490	425	—	—
	Copper	2370	760	540	580	490	—	—
C30	Alum.	3060	865	430	725	340	430	270
	Copper	3450	875	525	830	385	555	280
C40	Alum.	3290	560	580	580	595	480	495
	Copper	3680	570	755	605	540	640	570
C50	Alum.	3900	685	715	720	750	505	525
	Copper	4435	840	870	660	680	680	705
C60	Alum.	4885	885	820	855	985	620	720
	Copper	5820	935	1220	875	920	1010	860

Notes:

1. Mounting locations correlate with those shown in point loading illustration.
2. Operating weight includes refrigerant, oil and water.
3. Shipping weight includes refrigerant and oil charges.

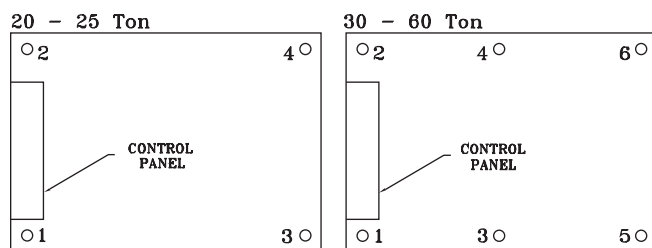

Unit Size	Shipping Weight (Max. Lbs.)	Center of Gravity			
		X		Z	
		Inches	mm	Inches	mm
C20	1875	39"	991	26"	660
C25	2085	40"	1016	26"	660
C30	3065	37"	940	30"	762
C40	3290	42"	1067	45"	1143
C50	3900	52"	1321	45"	1143
C60	4865	54"	1372	46"	1168

Figure 3
Rigging and Center-of-Gravity Data

WARNING
Heavy Objects!

Do not use cables (chains or slings) except as shown. Each of the cables (chains or slings) used to lift the unit must be capable of supporting the entire weight of the unit. Lifting cables (chains or slings) may not be of the same length. Adjust as necessary for even unit lift. Other lifting arrangements may cause equipment or property-only damage. Failure to properly lift unit could result in death or serious injury. See details below.

Note: Use spreader bars as shown in the diagram. Refer to the Installation manual or nameplate for unit weight. Refer to the Installation instructions located inside the control panel for further rigging information.

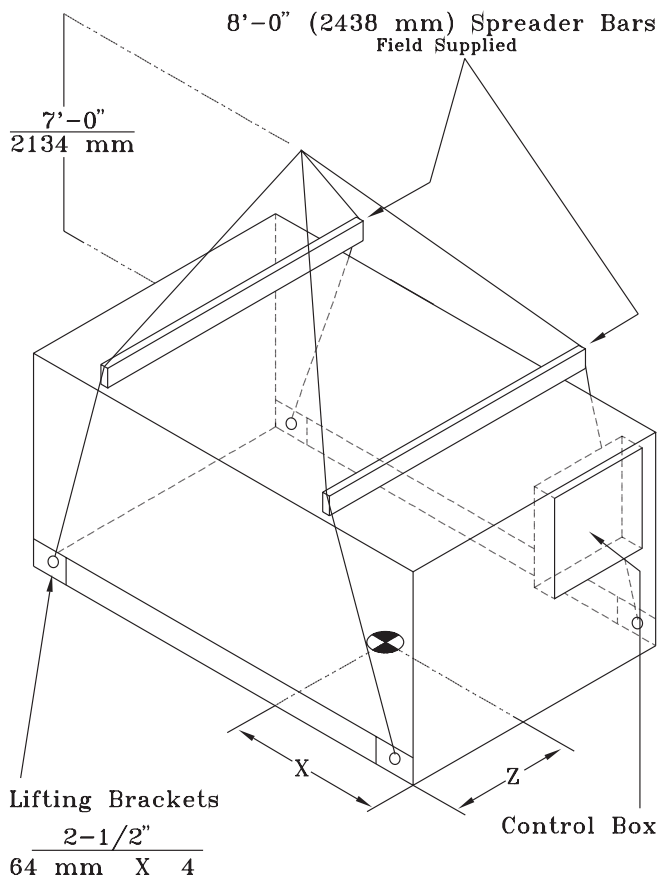

Installation

Rigging

A Rigging illustration and Center-of-Gravity dimensional data table is shown in Figure 3. Refer to the typical unit operating weights table before proceeding.

1. Rig the condensing unit as shown in Figure 3. Attach adequate strength lifting slings to all four lifting brackets in the unit base rail. Do not use cables, chains, or slings except as shown.
2. Install spreader bars, as shown in Figure 3, to protect the unit and to facilitate a uniform lift. The minimum distance between the lifting hook and the top of the unit should be 7 feet.
3. Test-lift the unit to ensure it is properly rigged and balanced, make any necessary rigging adjustments.
4. Lift the unit and position it into place.

Unit Isolation

To minimize unit sound and vibration transmission, one of the following installation methods should be used:

1. Install the unit directly on an isolated (detached) concrete pad or on isolated concrete footings located at each unit load point.
2. Install the optional neoprene or spring isolators at each mounting location. Refer to the following “Neoprene isolators” or “Spring Isolator” section.

Neoprene Isolators

Install the neoprene isolators at each unit mounting (load) point, using the following procedure:

1. Elevate the unit (one side at a time) to allow access to the base rail mounting holes.

WARNING

Isolator Installation!

Use solid type blocks, i.e. 4" X 4" wood blocks or similar material to prevent collapsing. Keep hands and other body limbs clear of elevated base rail while installing isolators to prevent personal injury.

2. Align the mounting holes in the base rail of the unit with the holes in the top of the appropriate isolator. Refer to Figure 4 for the appropriate isolator for each load point.
3. Install a 1/2" NC bolt (field supplied) through the base rail of the unit into the threaded bolt hole of the isolator. Position the isolator to allow access to the mounting holes in the base of the isolator, then tighten securely.
4. Lower the unit and isolator onto the mounting surface. The maximum isolator deflection should be approximately 1/4 inch.
5. Secure the isolator to the mounting surface using the base holes in the isolator.

6. Level the unit carefully. Refer to the “Leveling the Unit” section.

7. After the unit is level, tighten the isolator base mounting bolts to secure them to the mounting surface.

Spring Isolators

Install the spring isolators at each unit mounting (load) point using the following procedure:

1. Elevate the unit (one side at a time) to allow access to the base rail mounting holes.

WARNING

Isolator Installation!

Use solid type blocks, i.e. 4" X 4" wood blocks or similar material to prevent collapsing. Keep hands and other body limbs clear of elevated base rail while installing isolators to prevent personal injury.

2. Align the mounting holes in the base rail of the unit with the positioning pin in the top of the appropriate isolator. Refer to Figure 5 for the appropriate isolator for each load point.
3. Position the isolator to allow access to the mounting holes in the base of the isolator.
4. Lower the unit onto the isolator. The positioning pin on the isolator must engage into the hole of the base rail. The clearance between the upper and lower isolator housings should be approximately 1/4 to 1/2 inch. Refer to Figure 5. A clearance greater than 1/2 inch indicates that shims are required to level the unit. Refer to the “Leveling the Unit” section.
5. Make minor clearance adjustments by turning the isolator leveling bolt (Figure 5) clockwise to increase the clearance and counterclockwise to decrease the clearance. If proper isolator clearance cannot be obtained by turning the leveling bolt, level the isolators themselves. A 1/4 inch variance in elevation is acceptable.
6. Secure the isolator to the mounting surface using the base holes in the isolator.
7. After the unit is level, tighten the isolator base mounting bolts to secure them to the mounting surface.

Leveling the Unit

Before tightening the mounting bolts, level the unit carefully. Use the unit base rail as a reference. Level the unit to within 1/4 inch over its entire length. Use shims if non-adjustable isolators (neoprene) are used.

If adjustable isolators (spring) are used, ensure that the proper isolator housing clearance is maintained while leveling the unit. Isolators are identified by color and/or an isolator part number. Shims under the isolators may be required if the unit can not be leveled using the isolator leveling bolt.

Installation

Figure 4

Typical Neoprene Isolator Selection & Location

Unit Size	Fin Material	Neoprene Isolator Part Number @ Mounting Location					
		Location 1	Location 2	Location 3	Location 4	Location 5	Location 6
C20	Al	RDP-3-GRY	RDP-3-GRN	RDP-3-GRN	RDP-3-RED		
	Cu	RDP-3-GRY	RDP-3-GRN	RDP-3-GRN	RDP-3-GRN		
C25	Al	RDP-3-GRY	RDP-3-GRN	RDP-3-GRN	RDP-3-GRN		
	Cu	RDP-3-GRY	RDP-3-GRY	RDP-3-GRY	RDP-3-GRN		
C30	Al	RDP-4-BLK	RDP-3-GRN	RDP-3-GRY	RDP-3-RED	RDP-3-GRN	RDP-3-RED
	Cu	RDP-4-BLK	RDP-3-GRN	RDP-3-GRY	RDP-3-GRN	RDP-3-GRY	RDP-3-RED
C40	Al	RDP-3-GRY	RDP-3-GRY	RDP-3-GRY	RDP-3-GRY	RDP-3-GRN	RDP-3-GRN
	Cu	RDP-3-GRY	RDP-3-GRY	RDP-3-GRY	RDP-3-GRY	RDP-3-GRY	RDP-3-GRY
C50	Al	RDP-3-GRY	RDP-3-GRY	RDP-3-GRY	RDP-3-GRY	RDP-3-GRY	RDP-3-GRY
	Cu	RDP-4-BLK	RDP-4-BLK	RDP-3-GRY	RDP-3-GRY	RDP-3-GRY	RDP-3-GRY
C60	Al	RDP-4-BLK	RDP-4-BLK	RDP-4-BLK	RDP-4-BLK	RDP-3-GRY	RDP-3-GRY
	Cu	RDP-4-BLK	RDP-4-RED	RDP-4-BLK	RDP-4-BLK	RDP-4-BLK	RDP-4-BLK

Notes:

1. Mounting locations correlate with those shown in point loading illustration.

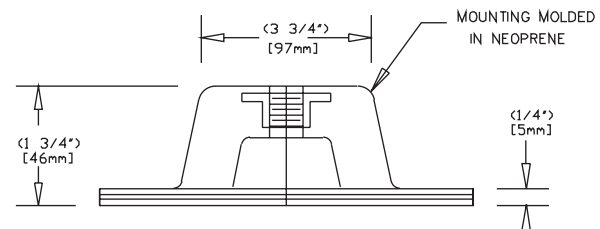
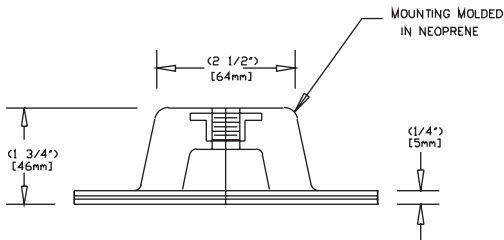
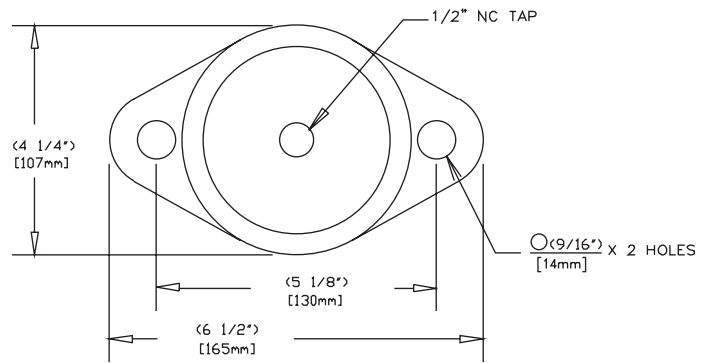
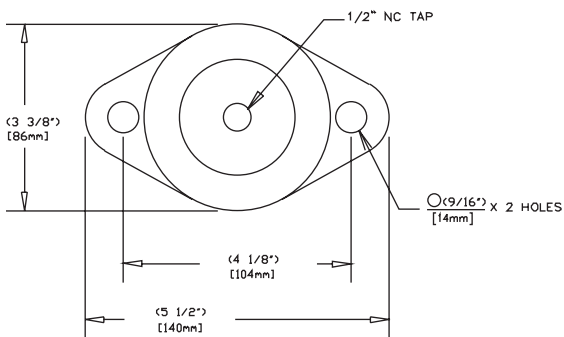

Installation

Figure 5
Typical Spring Isolator Selection & Location

Unit Size	Spring Isolator Part Number @ Mounting Location											
	Location 1		Location 2		Location 3		Location 4		Location 5		Location 6	
	AL	Cu	AL	Cu	AL	Cu	AL	Cu	AL	Cu	AL	Cu
C20	CP-1-28	CP-1-31	CP-1-27	CP-1-27	CP-1-27	CP-1-27	CP-1-26	CP-1-26				
C25	CP-1-31	CP-1-31	CP-1-27	CP-1-28	CP-1-27	CP-1-28	CP-1-26	CP-1-27				
C30	CP-1-32	CP-2-27	CP-1-27	CP-1-27	CP-1-31	CP-1-31	CP-1-26	CP-1-26	CP-1-27	CP-1-28	CP-1-25	CP-1-25
C40	CP-1-28	CP-1-28	CP-1-28	CP-1-31	CP-1-28	CP-1-28	CP-1-28	CP-1-28	CP-1-27	CP-1-28	CP-1-27	CP-1-28
C50	CP-1-31	CP-1-32	CP-1-31	CP-1-32	CP-1-31	CP-1-31	CP-1-31	CP-1-31	CP-1-28	CP-1-31	CP-1-28	CP-1-31
C60	CP-1-32	CP-2-27	CP-2-27	CP-2-28	CP-1-32	CP-2-27	CP-1-32	CP-2-27	CP-1-31	CP-1-32	CP-1-31	CP-2-27

Notes:

1. Mounting locations correlate with those shown in point loading illustration.
2. The spring number is marked on the outside of the spring housing, i.e. CP-1-25 is marked 25.
 The isolator spring is color coded as follows;
 CP-1-25 = Red CP-1-27 & CP-2-27 = Orange CP-1-31 & CP-2-31 = Gray
 CP-1-26 = Purple CP-1-28 & CP-2-28 = Green CP-1-32 = White
3. Refer to the "Spring Isolator" section, step 4, for proper clearance.

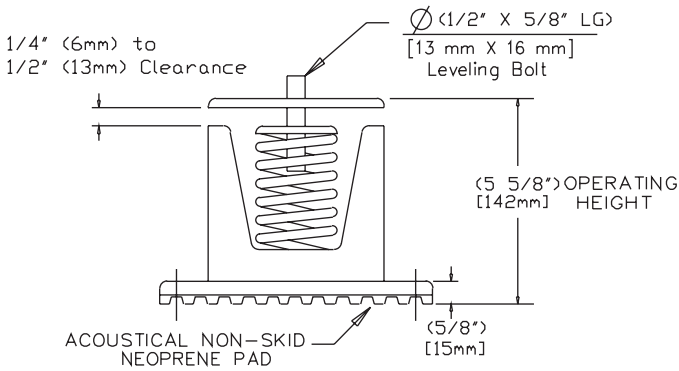

CP-1

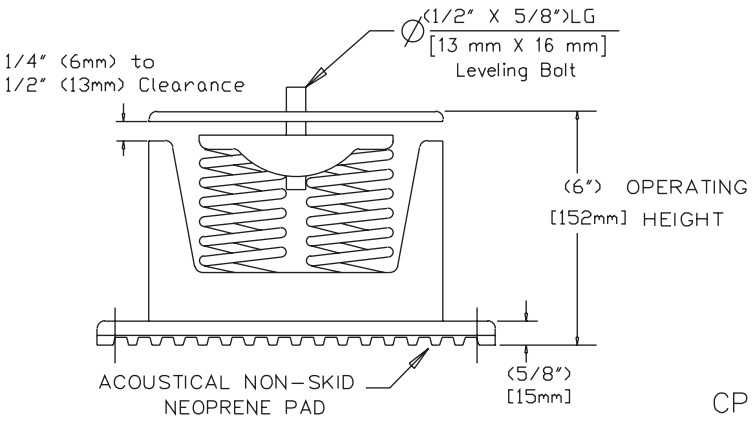
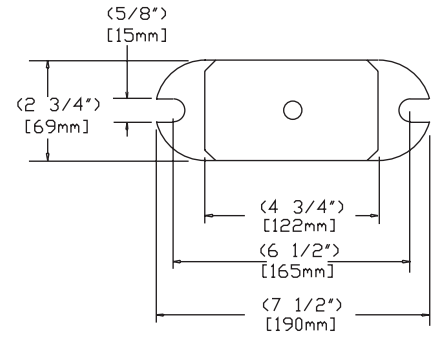

CP-2

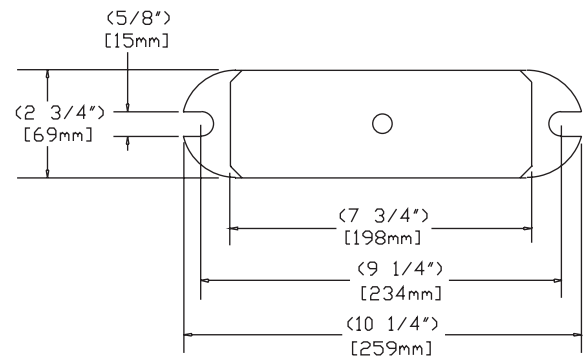

Installation

Shipping Fasteners

Compressor Shipping Hardware

Figure 6 illustrates the location of each tiedown bolt and rubber isolator bolt for the compressor assembly in each circuit. Refer to the illustration and the following discussion to locate and remove the fasteners.

Two Manifolder Compressors

Each manifolded compressor assembly is rigidly bolted to a mounting rail assembly. The rail assembly sets on four (4) rubber isolators. The assembly is held in place by two shipping braces that secure each compressor assembly rail to the unit's base rail. To remove the shipping hardware, follow the procedures below:

1. Remove the four anchor bolts (2 front and 2 rear), used to secure the shipping brace to the unit's base rail.
2. Remove the three self-tapping screws that secure each shipping brace to the compressor mounting rails.
3. Remove and discard the two 30-1/2" long shipping braces for each assembly.
4. Do not remove the shipping plate located on top of the compressors.
5. Ensure that the compressor rail assembly is free to move on the rubber isolators.

Figure 6

Removing C20 through C60 Scroll Compressor Shipping Hardware

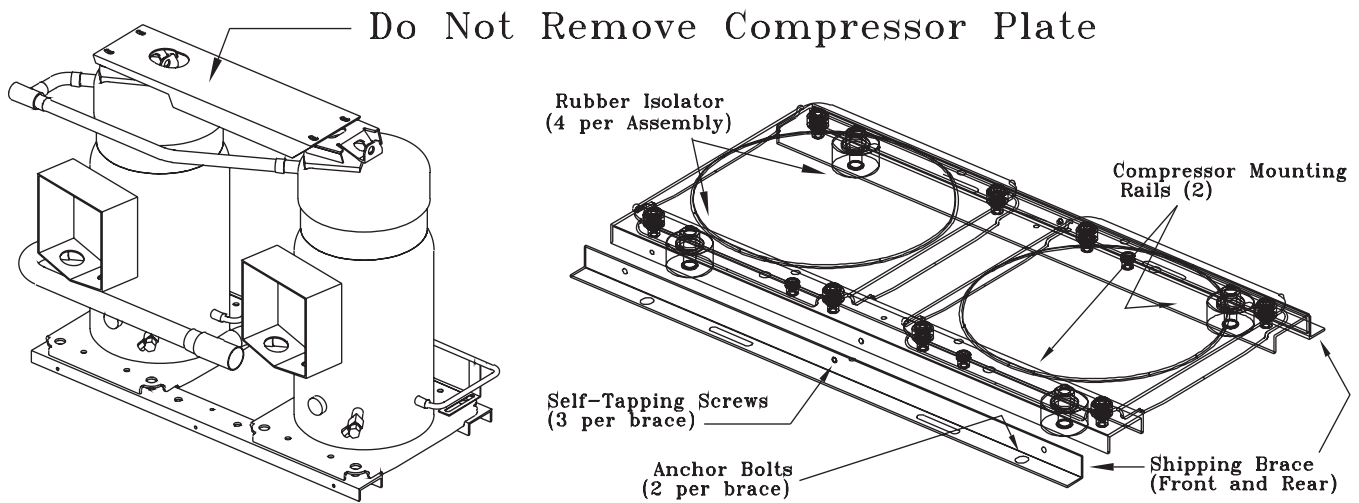

Installation

General Unit Requirements

The checklist listed below is a summary of the steps required to successfully install a commercial air cooled unit. This checklist is intended to acquaint the installing personnel with what is required in the installation process. It does not replace the detailed instruction called out in the applicable sections of this manual.

- [] Verify that the power supply complies with the unit nameplate specifications.
- [] Check the unit for shipping damage and material shortage; file a freight claim and notify Trane office.
- [] Verify that the installation location of the unit will provide the required clearance for proper operation.
- [] Install appropriate isolators, if required.

Chilled Water Piping Requirements

- [] Install properly sized chilled water pipe between the chiller and the supporting equipment. Refer to the “Chilled Water Piping” section for recommended system components and guidelines. Ensure that all necessary components have been installed:
 - Recommended:**
 - Water pressure gauges (with isolation valves)
 - Thermometers
 - Chiller isolation (shutoff) valves in the solution inlet and outlet piping
 - Pressure taps on the inlet and outlet at the chiller barrel
 - Chiller drain plug, or drain piping with a shutoff valve
 - Balancing valve
 - Required:**
 - Strainer in the solution inlet piping
 - Flow switch in the solution outlet piping
- [] Flushing the chilled solution piping system, if applicable.

Note: If using an acidic, commercial flushing solution, to prevent damage to the internal evaporator components, flush all chilled solution piping before making the final connection to the chiller.

- [] Connecting the chilled solution piping to the chiller barrel.
- [] Install heat tape and insulation, if necessary, to protect any exposed solution piping from external freezing conditions.

Main Electrical Power Requirements

- [] Verify the power supply meets the required power requirements of the system.

WARNING

Hazardous Voltage!

Disconnect all electric power, including remote disconnects before servicing. Follow proper lockout/tagout procedures to ensure the power can not be inadvertently energized. Failure to disconnect power before servicing could result in death or serious injury.

- [] Install power wiring in accordance with all applicable codes.

- [] Install and connect properly sized power supply wiring, with over current protection, to the main power terminal block (1TB1) or to an optional factory mounted nonfused disconnect switch (1S1) in the control panel.
- [] Install and connect properly sized power supply wiring, with over current protection, to the proper termination point in the air handling unit (if applicable).
- [] Install and connect properly sized power supply wiring, with over current protection, to the proper termination point for the chilled solution pump (chiller units only).
- [] Install proper grounding wires to an earth ground.

Field Installed Control Wiring Requirements

115 Volt Control Wiring

- [] Install the interlock circuitry wiring for the chilled water pump auxiliary contacts to the UCM to permit compressor operation after the chilled water pump has started. (i.e., proof of flow device, pump starter station, pump starter auxiliary contacts, etc). Refer to the Field Connection Diagram that shipped with the unit for interlocking information.

Low Voltage Wiring (AC & DC)

- [] Verify that the proper connections have been made at the UCM for the remote running/alarm indication contacts (if applicable).
- [] Verify that the proper connections have been made for external auto/stop (if applicable).
- [] Verify that the proper connections have been made for the optional chilled water flow switch (if applicable).
- [] Verify that the proper connections have been made at the UCM for the optional compressor inhibit/KW limit function (if applicable).
- [] Verify that the proper connections have been made at the UCM for the optional external Auto/Stop (if used).
- [] Verify that the proper connections have been made for the zone sensor(s) at the UCM for chilled solution set-point reset based on zone temperature.
- [] If the unit is a component of an ice storage system, verify that the remote contact connections have been made at the UCM for ice machine control.
- [] Verify that the proper connections have been made between the UCM and the bidirectional communication link device (Tracer™ or other remote device, if applicable).
- [] Verify that the shielded twisted-pair communication wire between the UCM and the remote display panel has been connected (if applicable).

Chilled Water Piping

Evaporator water inlet and outlet types, sizes and locations are shown in Figure 2. Refer to the operating GPM parameters listed in Table 9 when determining flow and piping requirements. Figure 8 illustrates the typical water piping components for chiller applications. Refer to this illustration while following the discussion on the various piping components.

Isolate the water pumps from the system to avoid vibration transmission. To minimize heat gain and prevent condensation, insulate all water piping. Use an appropriate pipe sealant on all threaded connections.

Chilled Water Access Holes

These units have water access panels that contain perforated "circles" and panel separations (30 to 60 ton chillers allow access through either of two sides. See Figure 7A). Removing these "circles" provides piping access to the chiller. Each panel contains one or two perforated "circles", remove both perforated "circles" per panel. Therefore, follow these steps to ensure proper panel modification.

1. Refer to Figure 7A and mark an "X" on the outer perforated "circle" in each water access panel. (These are aligned with the water inlet and outlet piping on the heat exchanger).
2. Remove all the screws located below the perforation of both panels. Do not remove any screws above the perforation.
3. Break both panels at the perforation by grasping them near the bottom and bending with a back and forth motion.
4. Remove the resulting "half-moon" sections that were marked with an "X".

Note: Remove only the "half-moon" sections that were marked with an "X".

5. For 50 and 60 Ton units, an additional perforated section in the upright brace behind the access panels must be removed. Break this piece out with pliers and discard.
6. Apply edge protector to the upper and lower portions of both panels along the entire length of the broken perforation as shown in Figure 7B. (The edge protector is factory provided, and is secured to the chiller foot).
7. Reinstall the lower halves of the water access panels and secure them with the screws that were removed in step two.

Note: The gap between the insulated pipe and the access holes must not exceed 1/2 inch. Refer to Figure 7C.

Air Vents

A vent port is located on top of the chiller near the return end. Additional vents must be installed at high points in the piping system to facilitate air purging during the filling process.

Installation

Water Pressure Gauges

Install pressure gauge(s) at the chiller barrel to monitor the entering and leaving solution pressure.

Note: To prevent evaporator damage, do not exceed 150 psig evaporator pressure.

Water Shutoff Valves

Provide shutoff valves in the "Supply" and "Return" pipe near the chiller so the gauge(s), thermostats, sensors, strainer, etc., can be isolated during service.

Pipe Unions

Use pipe unions to simplify disassembly for system service. Use vibration eliminators to prevent transmitting vibrations through the water lines

Thermometers

Install thermometers in the lines to monitor the evaporator entering and leaving water temperatures.

Balancing Valves

Install a balancing cock (valve) in the leaving water line. It will be used to establish a balanced flow.

Note: Both the entering and leaving water lines should have shutoff valves installed to isolate the evaporator for service.

Strainer

The strainer is factory provided and should be installed in the water line entering the chiller to protect the evaporator from entrapped debris.

Chiller Drain

The chiller drain should be piped to a suitable drain facility to facilitate evaporator draining during service or shutdown procedures. Provide a shutoff valve in the drain line.

Note: The chiller ships without the drain plug installed. If drain piping is not installed, remove the drain plug from the control panel and install it in the drain port before filling the system with water.

WARNING

Hazardous Voltage!

Disconnect all electric power, including remote disconnects before servicing. Follow proper lockout/tagout procedures to ensure the power can not be inadvertently energized. Failure to disconnect power before servicing could result in death or serious injury.

Chiller Flow Switch

Install the factory provided flow switch or other flow sensing device, illustrated in Figure 9, to prevent or stop the compressor operation if the water flow drops off drastically. A flow switch ships standard with each unit. Locate the device in the chilled water supply line (water outlet) as shown in Figure 8. Refer to the field wiring and unit schematics for the flow switch electrical interlock connections.

Figure 7A
Typical Water Access Holes for 20 through 60 Ton Units

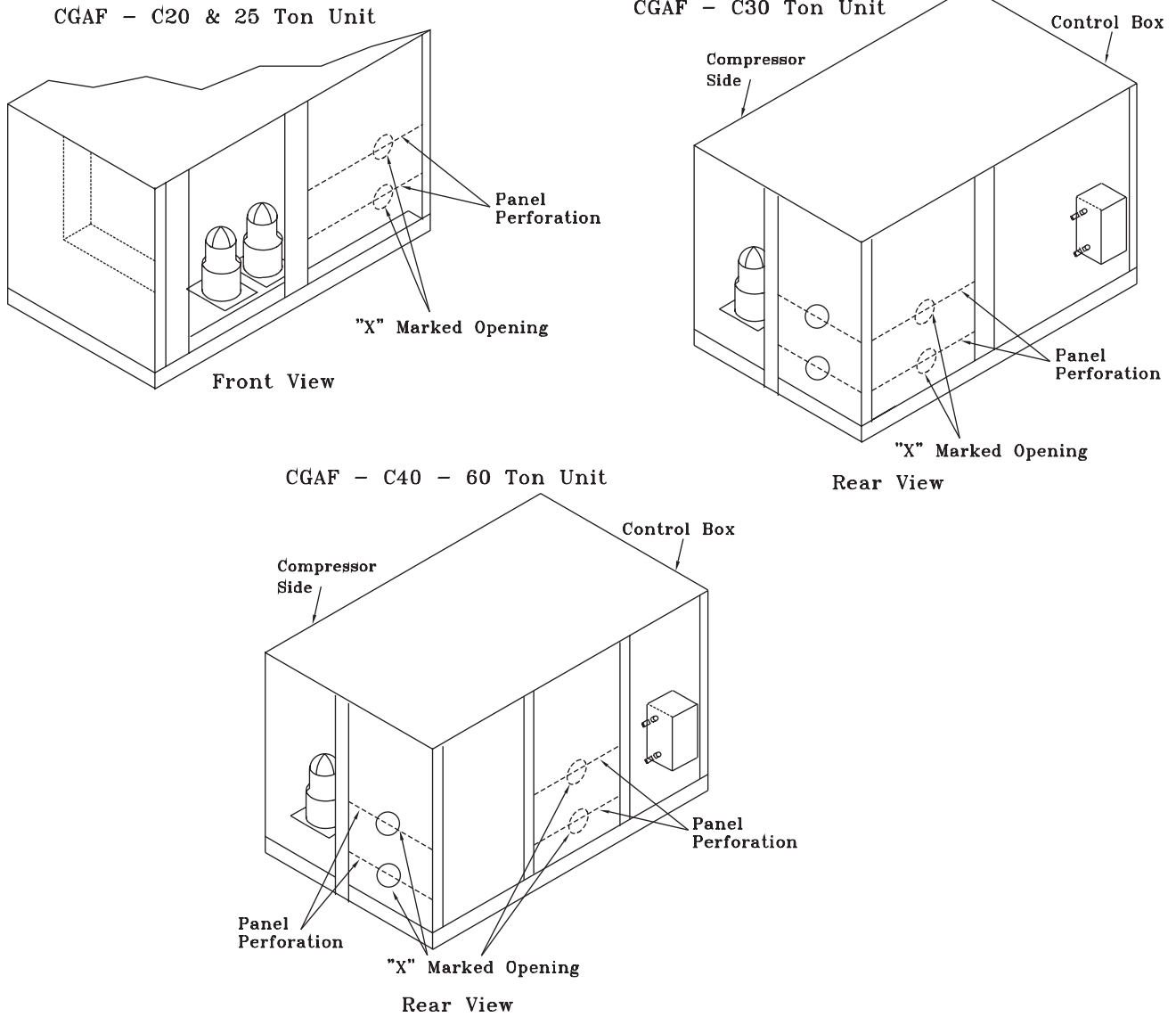

Figure 7B
Edge Protector Installation

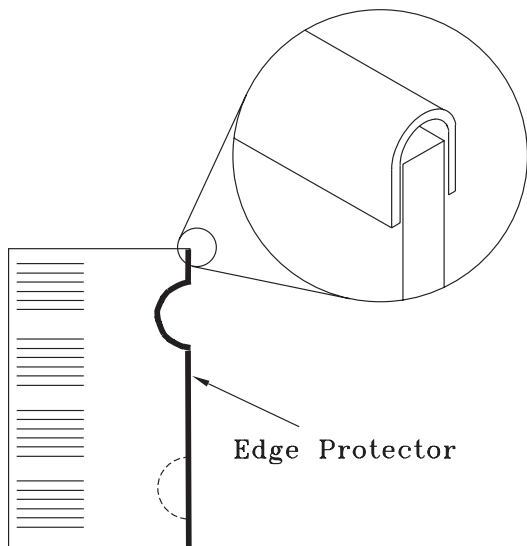
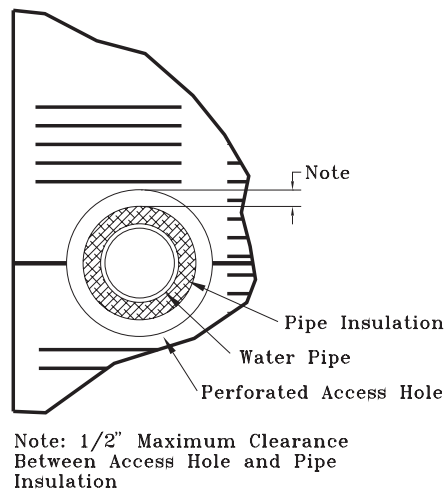

Figure 7C
Clearance Requirements Around Water Pipe



Note: 1/2" Maximum Clearance
 Between Access Hole and Pipe
 Insulation

Installation

Figure 8
Typical Water Piping Recommendations

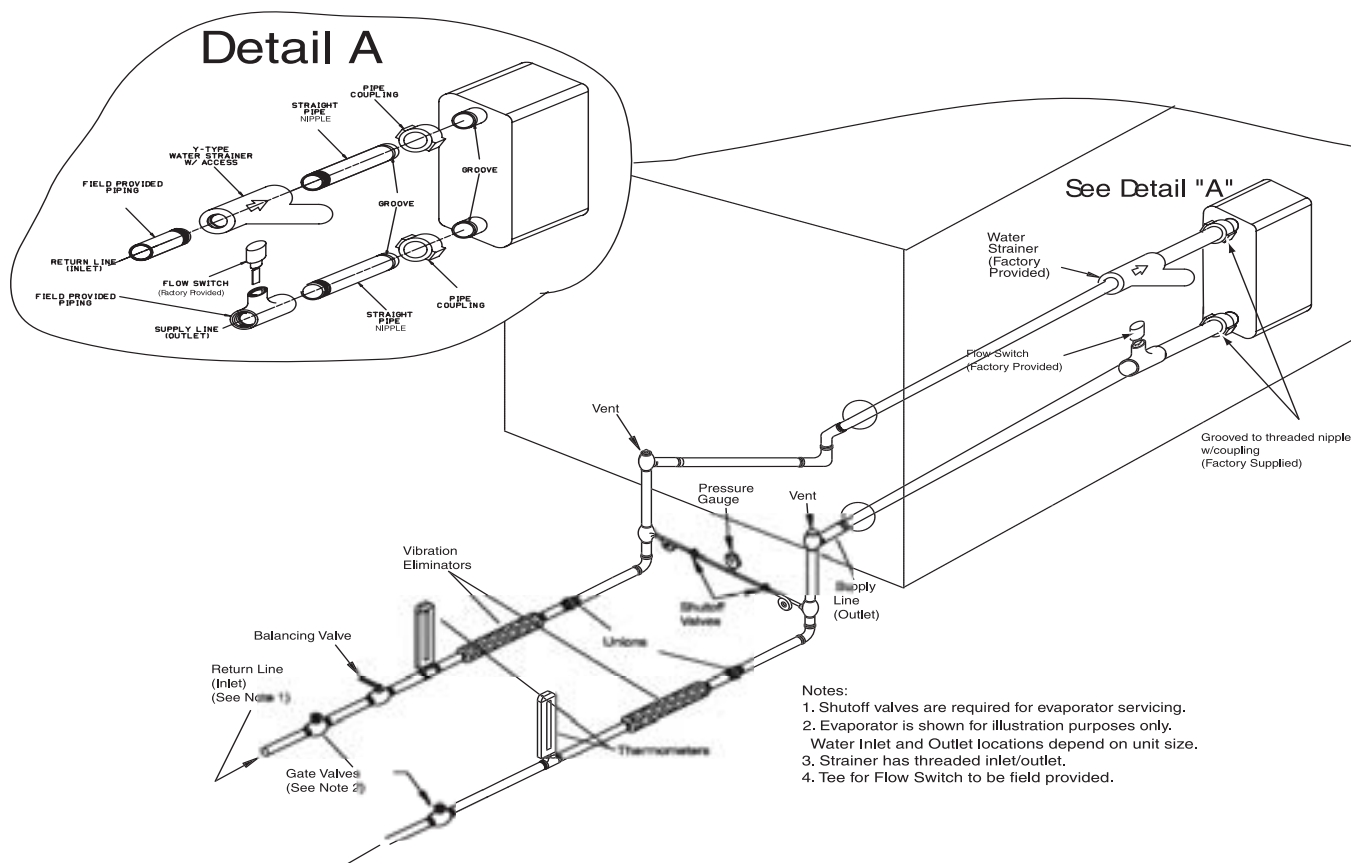
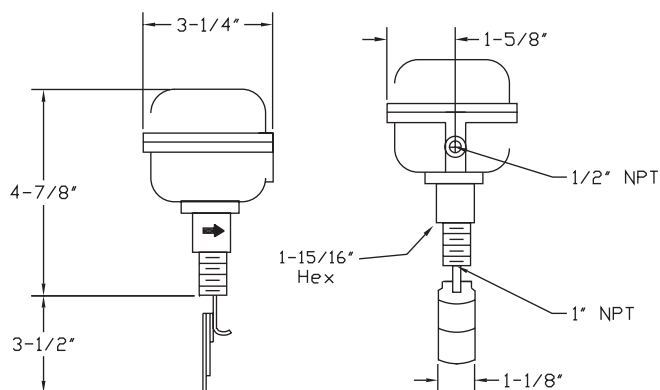

Figure 9
Required Flow Switch Illustration



Final Water Piping Connections

1. All water piping to the system should be flushed thoroughly before making the final connections.

Note: If an acidic commercial flushing solution is used, construct a temporary bypass around the chiller to prevent damage to the internal components of the evaporator.

2. Connect the water pipe to the chiller.
3. Install the drain plug, (if no drain is used) or ensure the drain shutoff valve is closed.
4. While filling the chiller system with solution, vent the air from the system at the highest points.

Note: To prevent possible damage to the equipment, do not use untreated or improperly treated water in the system.

Freeze Protection from Ambient Conditions

Use the procedure described below to ensure that the chilled water system is adequately protected from freeze-up in applications where the unit remains operational at sub-freezing ambient temperatures and against ice formation at the lowest expected operating temperatures by adding a non-freezing, low-temperature, heat-transfer fluid to the chilled water.

Ice making units with a termination setpoint of 27°F minimum entering chilled water temperature require a 25 percent glycol solution (minimum requirement by weight) to provide system freeze protection.

For evaporator water capacities, refer to the "System Start-Up" section. For the use and testing of the antifreeze solution, follow the manufacturer's recommendations.

Note: Use of an ethylene glycol-type antifreeze reduces unit cooling capacity; this condition must be accounted for during total system design. Also, the low pressure control may need to be changed. Contact the local Trane representative.

For all 60 Hz units, heat tape is factory-installed on the unit evaporator. Heat tape is optional on 50 Hz units. This heat tape will protect the evaporator from freezing due to low ambient temperatures down to -20°F. Heat tape power draw for 60 Hz units is 125 Watts on 20 through 30 Ton units, and 250 Watts on 40 through 60 Ton units. For 50 Hz units, heat tape power draw is 420 Watts on all units.

Internal/External Piping Heat Tape (Field Provided)

Install an appropriately sized non-unit powered fused disconnect switch for the heat tape when applying it to all exposed piping. Be sure to use heat tape that is recommended for low-temperature applications. It should be thermostatic controlled and dissipate 7 watts per linear foot. A field installed thermostat must be installed if the heat tape does not include a thermostat.

To install the heat tape properly, follow the instructions provided by the heat tape manufacturer. If no instructions are provided, use the recommendations outlined below:

Figure 10
Typical Insulated, Spiralled Heat Tape Installation

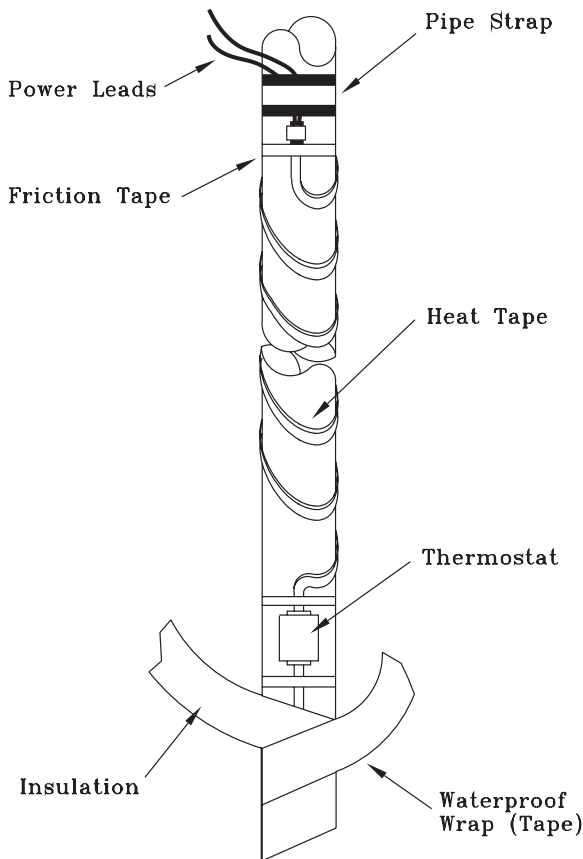

Installation

1. Wrap the heat tape around the pipe or apply it straight along the pipe, as necessary, to provide the required protection. Refer to Tables 2A and 2B.
2. Use friction tape to secure the heat tape to the solution pipe.
3. Place the thermostat parallel to the water pipe and tape it tightly in place at both ends. Be sure to install the thermostat on the most exposed (i.e., coldest) portion of the pipe.
4. Wrap the pipe with an insulation material and cover it with a weatherproof tape (if additional protection is required). On vertical pipe runs, start the wrap at the bottom and work up as shown in Figure 10. Be sure to overlap the tape so that it will shed moisture.

Note: To prevent heat tape failure, frozen pipes, and other unit damage, do not install insulation under the weatherproof wrap if a non-thermostatic controlled heat tape is used.

Table 2A
Non-Insulated, Non-Thermostatically controlled Heat Tape with Outer Wrap

Application Technique	Pipe Size				
	2"	2-1/2"	3"	4"	5"
"Straight"					
Heat Tape Req. per Linear Ft. of Pipe	12"	12"	12"	12"	12"
Protection Down to (°F)	6°	11°	15°	20°	22°
"Spiralled"					
Heat Tape Req. per Linear Ft. of Pipe	28"	31"	35"	47"	54"
Protection Down to (°F)	-27°	-23°	-20°	-17°	-15°

Note: Spiralled applications are twisted around pipe 3 turns per linear foot of pipe.

Table 2B
Insulated, Non-Thermostatically controlled Heat Tape with Outer Wrap

Application Technique	Pipe Size				
	2"	2-1/2"	3"	4"	5"
"Straight":					
Heat Tape Req. per Linear Ft. of Pipe	12"	12"	12"	12"	12"
Protection Down to (°F)	-6°	0°	3°	12°	16°
"Spiralled":					
Heat Tape Req. per Linear Ft. of Pipe	26"	31"	35"	47"	54"
Protection Down to (°F)	-55°	-50°	-45°	-40°	-1°

Note: Spiralled applications are twisted around pipe 3 turns per linear foot of pipe.

Installation

Field Installed Power Wiring

An overall dimensional layout for the field installed wiring entrance into the unit is illustrated in Figure 2. To insure that the unit's supply power wiring is properly sized and installed, follow the guidelines outlined below.

Note: All field installed wiring must conform to NEC guidelines as well as State and Local codes.

Verify that the power supply available is compatible with the unit's nameplate ratings. The available supply power must be within 10% of the rated voltage stamped on the nameplate. Use only copper conductors to connect the 3-phase power supply to the unit.

CAUTION

Use Copper Conductors Only!

Unit terminals are not designed to accept other types of conductors. Failure to use copper conductors may result in equipment damage.

Disconnect Switch External Handle (Factory Mounted Option)

Units ordered with the factory mounted nonfused disconnect switch comes equipped with an externally mounted handle. This allows the operator to disconnect power from the unit without having to open the control panel door. The handle locations and its three positions are shown below;

“ON” - Indicates that the disconnect switch is closed, allowing the main power supply to be applied at the unit.

“OFF” - Indicates that the disconnect switch is open, interrupting the main power supply to the unit controls.

“OPEN COVER/RESET” - Turning the handle to this position releases the handle from the disconnect switch, allowing the control panel door to be opened.



WARNING Hazardous Voltage!

Disconnect all electric power, including remote disconnects before servicing. Follow proper lockout/tagout procedures to ensure the power can not be inadvertently energized. Failure to disconnect power before servicing could result in death or serious injury.

Once the door has been opened, it can be closed with the handle in any one of the three positions outlined above, provided it matches the disconnect switch position.

The handle can be locked in the “OFF” position. While holding the handle in the “OFF” position, push the spring loaded thumb key, attached to the handle, into the base slot. Place the lock shackle between the handle and the thumb key. This will prevent it from springing out of position.

An overall layout of the field required power wiring is illustrated in Figure 11. These diagrams are representative of standard applications and are for general reference only. Always refer to the wiring diagram that shipped with the unit for specific electrical schematic and connection information.

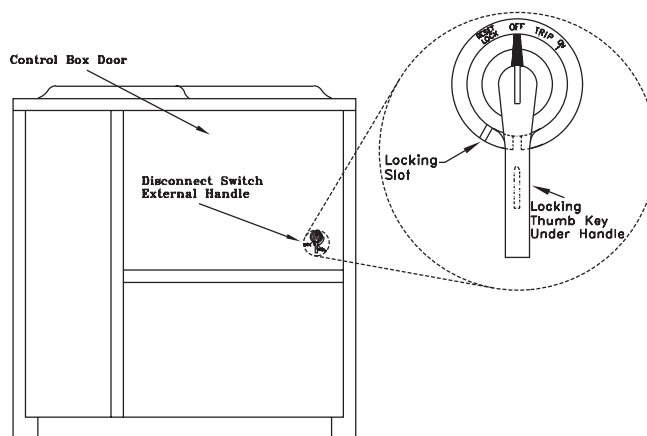

Main Unit Power Wiring

Table 3 lists the field connection wire ranges for both the main power terminal block 1TB1 and the optional factory mounted nonfused disconnect switch 1S14. The unit electrical data is listed in Table 4. The electrical service must be protected from over current and short circuit conditions in accordance with NEC requirements. Protection devices must be sized according to the electrical data on the nameplate. Refer to the “Power Wire Sizing & Protection Device Equations”, for determining;

- the appropriate electrical service wire size based on “Minimum Circuit Ampacity” (MCA),
- the “Maximum Over current Protection” (MOP) device.
- the “Recommended Dual Element fuse size” (RDE).

- If the unit is not equipped with an optional factory installed nonfused disconnect switch, a field supplied disconnect switch must be installed at or near the unit in accordance with the National Electrical Code (NEC latest edition). Refer to the “Power Wire Sizing & Protection Device Equations” (DSS calculation), for determining the correct size.
- Complete the unit's power wiring connections onto either the main terminal block 1TB1, or the factory mounted nonfused disconnect switch 1S14, inside the unit control panel. Refer to the customer connection diagram that shipped with the unit for specific termination points.

Installation

Figure 11
Typical Field Installed Power Wiring
Refer to the Wiring Diagram Notes at the end of this Section

Table 3
Customer Connection Wire Range

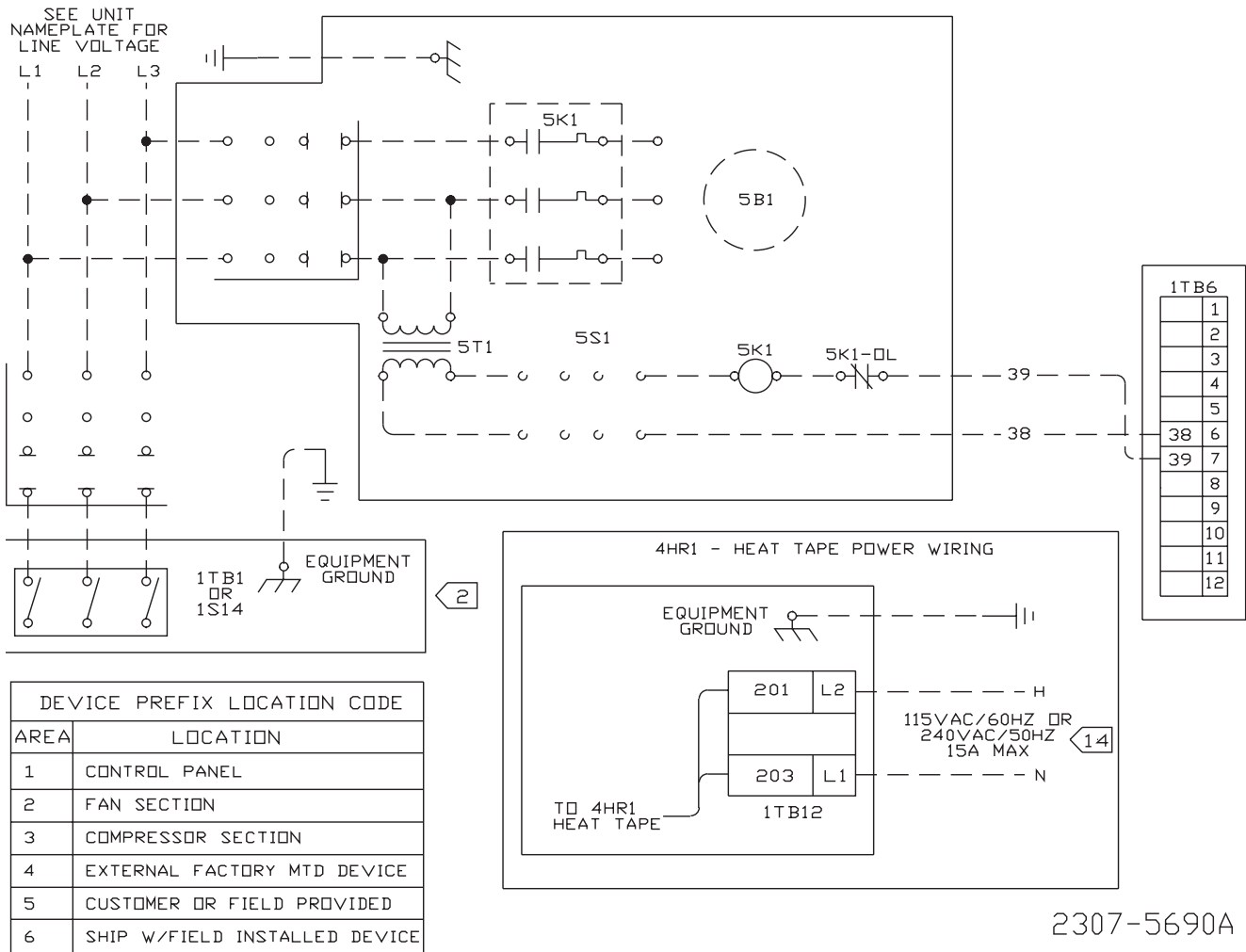

CUSTOMER CONNECTION WIRE RANGE			
NOTES A. BLOCK SIZE DISCONNECT SIZE ARE CALCULATED BY SELECTING THE SIZE GREATER THAN OR EQUAL TO 1.15 X (SUM OF UNIT LOADS). SEE UNIT LITERATURE FOR UNIT LOAD VALUES.		UNITS WITH MAIN POWER TERMINAL BLOCK (ALL VOLTAGES)	
		BLOCK SIZE 335 AMP	CONNECTOR WIRE RANGE (1) #6 - 350 MCM
UNITS WITH MAIN POWER DISCONNECT SWITCH			
UNIT TONNAGE 20-40 50 20-40 50-60 60 50-60	UNIT VOLTAGE 380-415-460-575V 575V 200-230V 380-415-460V 575V 200-230V	DISCONNECT SIZE 100 AMP 100 AMP 250 AMP 250 AMP 250 AMP 400 AMP	CONNECTOR WIRE RANGE (1) #14 - 1/0 (1) #14 - 1/0 (1) #4 - 350 kcmil (1) #4 - 350 kcmil (1) #4 - 350 kcmil (1) #1-600 kcmil OR (2) #1-250 kcmil

Installation

Table 4
Unit Electrical Data

Unit Size	Rated Voltage ⁶	Min.	Max.	Compressor Motor (Each) ⁵			Cond. Fan Motors (Each)		
		Ckt. Amp. ¹	Fuse Size ^{2,3}	Qty.	RLA ⁴	LRA	Qty.	FLA	Kw
CGAF 20	200/60/3	98	125	2	39.4	269	2	4.1	0.9
	230/60/3	98	125	2	39.4	251	2	4.1	0.9
	460/60/3	44	60	2	17.2	117	2	1.8	0.9
	575/60/3	33	45	2	13.2	94	2	1.4	0.9
	380/50/3	44	60	2	17.2	110	2	1.7	0.75
	415/50/3	44	60	2	17.2	110	2	1.7	0.75
CGAF 25	200/60/3	124	175	2	39.3/56.9	269/409	3	4.1	0.9
	230/60/3	124	175	2	39.3/56.9	251/376	3	4.1	0.9
	460/60/3	56	80	2	17.1/25.4	117/178	3	1.8	0.9
	575/60/3	44	60	2	13.8/20.2	95/143	3	1.4	0.9
	380/50/3	55	80	2	17.3/25.2	110/174	3	1.7	0.75
	415/50/3	55	80	2	17.3/25.2	110/174	3	1.7	0.75
CGAF 30	200/60/3	146	200	2	56.9	409	4	4.1	0.9
	230/60/3	146	200	2	56.9	376	4	4.1	0.9
	460/60/3	65	80	2	25.1	178	4	1.8	0.9
	575/60/3	51	70	2	19.9	143	4	1.4	0.9
	380/50/3	65	80	2	25.2	174	4	1.7	0.75
	415/50/3	65	80	2	25.2	174	4	1.7	0.75
CGAF 40	200/60/3	187	225	4	39.4	269	4	4.1	0.9
	230/60/3	186	225	4	39.4	251	4	4.1	0.9
	460/60/3	82	90	4	17.2	117	4	1.8	0.9
	575/60/3	62	70	4	13.2	95	4	1.4	0.9
	380/50/3	81	90	4	17.2	110	4	1.7	0.75
	415/50/3	81	90	4	17.2	110	4	1.7	0.75
CGAF 50	200/60/3	224	250	4	35.5/55.5	269/409	6	4.1	0.9
	230/60/3	223	250	4	35.5/55.5	251/376	6	4.1	0.9
	460/60/3	98	110	4	16.5/24.2	117/178	6	1.8	0.9
	575/60/3	77	90	4	12.4/19.4	94/143	6	1.4	0.9
	380/50/3	97	110	4	15.5/24.2	110/174	6	1.7	0.75
	415/50/3	97	110	4	15.5/24.2	110/174	6	1.7	0.75
CGAF 60	200/60/3	270	300	4	56.9	409	6	4.1	0.9
	230/60/3	269	300	4	56.9	376	6	4.1	0.9
	460/60/3	120	125	4	25.4	178	6	1.8	0.9
	575/60/3	95	110	4	20.2	143	6	1.4	0.9
	380/50/3	119	125	4	25.2	174	6	1.7	0.75
	415/50/3	119	125	4	23.2	174	6	1.7	0.75

Notes:

1. Minimum Circuit Ampacity is 125% of the largest compressor RLA plus 100% of the other compressor RLA plus the sum of the condenser fan FLA plus any other load rated at 1 Amp or more.
2. Maximum Fuse Size is 225% of the largest RLA plus 100% of the other compressor RLA plus the sum of the condenser fan FLA plus any other load rated at 1 Amp or more.
3. Recommended Dual Element Fuse Size is 150% of the largest compressor RLA plus 100% of the other compressor RLA plus the sum of the condenser fan FLA plus any other load rated at 1 Amp or more.
4. RLA is rated in accordance with UL Standard 465. Local codes may take precedence.
5. All units are across-the-line starting. Compressors will never start simultaneously.
6. (60 Hz units) One field provided 115/60/1, 15 amp power supply is required to operate the evaporator heat tape.
(50 Hz units) One field provided 240/50/1, 5 amp power supply is required to operate the evaporator heat tape.

Installation

Field Installed Control Wiring

Before installing any connecting wiring, refer to Figure 2 for the electrical access locations provided on the unit. Install appropriately sized control wiring for the 115 volt electrical components as required by the application.



WARNING **Hazardous Voltage!**

Disconnect all electric power, including remote disconnects before servicing. Follow proper lockout/tagout procedures to ensure the power can not be inadvertently energized. Failure to disconnect power before servicing could result in death or serious injury.

Since the unit-mounted 115V control power transformer (1T1) and the 24V control power transformers (1T2, 1T3, 1T4) is provided on all units, it is not necessary to run a separate 115 volt control circuit power source to the unit.

A separate field provided 15 Amp maximum 115V 60 Hz or 240V 50 Hz power source is required when the unit is equipped with heat tape. Refer to the wiring diagrams that shipped with the unit for proper connections.

Note: All field wiring must conform to NEC guidelines as well as state and local codes.

Controls Using 115 VAC

Install appropriately sized 115 volt control wiring for the following electrical components.

Circulating Pump Interlock

Pump interlock wiring is the responsibility of the installer. During compressor operation, the solution flow through the chiller must be maintained. The field provided; 5S1 disconnect switch, 5K1 pump starter, 5K1 overloads (OL's) must be installed and properly wired as part of the system's interlock circuit. Maximum contact rating @ 115 VAC is 1 amp inductive. A Solution Pump binary output (Form A) relay is located on the CGM which may be used to control the chiller solution pump. Refer to the illustrations in Figures 11 and 12A for the typical "field wiring" interlock diagrams.

Controls using 24 VAC

Before installing any connecting wiring, refer to Figure 2 for the electrical access locations provided on the unit and Table 5 for AC conductor sizing guidelines, and;

- Use copper conductors unless otherwise specified.
- Ensure that the AC control wiring between the controls and the unit's termination point does not exceed three (3) ohms/conductor for the length of the run.

Note: Resistance in excess of 3 ohms per conductor may cause component failure due to insufficient AC voltage supply.

- Be sure to check all loads and conductors for grounds, shorts, and miswiring.

- Do not run the AC low voltage wiring in the same conduit with the high voltage power wiring.

Install appropriately sized 24 volt AC/DC control wiring for the electrical components as required by the application.

These components may include:
Remote Running/Alarm Indicator
External Auto/Stop
Flow Control Interlock

Table 5
AC Conductors

Distance from Unit to Control	Recommended Wire Size
000 - 460 feet	18 gauge
461 - 732 feet	16 gauge
733 - 1000 feet	14 gauge

Remote Running/Alarm Indicator (Optional)

If the remote run indication and alarm contacts are used, a 24 VAC control circuit must be provided between the Remote Running/Alarm Indicator panel and the appropriate terminals located at the UCM. Maximum contact rating @ 24 VAC is 10 Amp inrush and 3.2 Amp sealed. Refer to the "field wiring" diagrams illustrated in Figure 12A. Provide a proper remote panel ground connection.

External Auto/Stop (Optional)

If the unit utilizes an optional remote Auto/Stop function, the installer must provide control wiring from the remote pump relay contacts (5S67) to the appropriate terminals on 1TB4 terminal board.

When this set of contacts opens, the UCM reads it as a command to stop chiller operation and begin the pumpdown cycle (if enabled).

Circuit requirements are 2-wire, 24 VDC; w/maximum contact rating 12 mA. Refer to the field wiring diagram illustrated in Figure 12A for the termination points.

Flow Control Interlock (6S1)

The required flow switch is a binary output device and is wired within the interlock circuit providing (required) chilled water flow interlock diagnostic for the system. Before installing the control wiring, refer to Figure 2 for the electrical access into the control panel. Refer to the field connection diagram for the specific connection points.

Provide a proper ground for all control circuitry at the ground connection screws provided within the unit's control panel.

Controls using DC Analog Input/Outputs (Standard Low Voltage Multiconductor Wire)

Before installing any connecting wiring between the unit and components utilizing a DC analog input/output signal, refer to Figure 2 for the electrical access locations provided on the unit.

- Table 6 lists the conductor sizing guidelines that must be followed when interconnecting the DC binary output devices and the system components utilizing a DC analog input/output signal to the unit.

Installation

Note: Resistance in excess of 2.5 ohms per conductor can cause deviations in the accuracy of the controls.

- b. Ensure that the wiring between the binary and analog controls and the unit's termination point does not exceed two and a half (2.5) ohms/conductor for the length of the run.
- c. Do not run the electrical wires transporting DC signals in or around conduit housing high voltage wires.

**Table 6
DC Conductors**

Distance from Unit to Control	Recommended Wire Size
000 - 499 feet	16 gauge
500 - 1000 feet	14 gauge

Controls using DC Communication Links

Before installing any connecting wiring between the unit and components utilizing a DC communication link, refer to the connection diagram that shipped with the unit for the electrical access and connection locations provided on the unit.

- a. Wiring for the components utilizing a DC communication link must be shielded cable (Belden 8760 or equivalent). Ground the shield at one end only.
- b. Table 2 lists the conductor sizing guidelines that must be followed when interconnecting a communication link to the unit.
- c. Communication link must not exceed 5,000 feet maximum for each link.
- d. Communication link must not pass between buildings.
- e. Do not run the electrical wires transporting DC signals in or around conduit housing AC voltage wires.

**Table 7
Maximum Communications Wiring Length**

Maximum Communication Link Wiring Length	Maximum Capacitance Between Conductors
1,000 feet	Up to 60 PF/FT
2,000 feet	Up to 50 PF/FT
3,000 feet	Up to 40 PF/FT
4,000 feet	Up to 30 PF/FT
5,000 feet	Up to 25 PF/FT

PF/FT = Picofarads/foot

BAS/NETWORK Communication Link

This option allows the unit control module (UCM) in the unit to exchange information (i.e., operating setpoints and AUTO/STOP commands) with a higher level control device, such as a Tracer or a third party BAS. Twisted-pair conductors establish the bi-directional communications link between the unit's control module and Tracer or a third party BAS.

1. Refer to the Tracer installation literature to determine proper communication link termination connections at the Tracer unit. Multiple UCM's on the communication link can be connected in a "daisy chain" configuration.
2. Connect the shield of the communication link wiring to the designated shield terminal at the Tracer 100.
3. Connect the shielded, twisted pair leads from the Tracer to the proper terminals on the UCM. There is no polarity requirement for this connection.
4. At the UCM, the shield should be cut off and taped to prevent any contact between the shield and ground.

Note: On multiple unit installations, connect the shield between each "daisy-chained" UCM in the system to the shield of the twisted-pair leads going to the next unit in line. Tape the spliced connection to prevent any contact between the shield and ground. At the last UCM on the link, the shield should be cut off and taped.

Ice Building Control Option

The CGM provides auxiliary control for a customer specified/installed contact closure for ice making. When this field installed normally open contact (5K86) is provided, the chiller will run normally. Upon contact closure, the unit will operate fully loaded until the entering water temperature falls below the preprogrammed ice building setpoint. High quality silver or gold-plated contacts are recommended. The field supplied contacts must be compatible with 24 VDC, 12 mA resistive load.

Connect the 5K86 relay contacts to the proper terminals on 1TB4 as illustrated in Figure 12A.

Compressor Inhibit / KW Limit

When a unit is equipped with a TCI module, the Demand Limit request is communicated from Tracer. When a unit is equipped with GBAS (0-5V and/or 0-10V), a customer provided/installed remote contact (5K89) initiates the demand limit function. When the contact is "Open", the chiller will operate normally. When the contact closes, the unit will be limited to the programmed operating capacity (25%, 50%, 75%, or 100%). When the contact opens, normal chiller operation is restored.

High quality silver or gold-plated contacts are recommended. These customer-supplied contacts must be compatible with 24 VDC, 12 mA resistive load. Refer to the wire selection Table 6 for proper wire size and Figure 12B or Figure 12C for proper termination points.

Connect the wiring from the field supplied normally open contacts between terminals 5 and 6 on 1TB16, if 0 - 5 Volt GBAS is installed.

Connect the wiring from the field supplied normally open contacts between terminals 1 and 2 on 1TB17, if 0 - 10 Volt GBAS is installed.

Connect the wiring from the field supplied normally open contacts between the proper terminals on 1TB16 and 1TB17 when both GBAS modules are installed. Refer to the appropriate wiring diagram illustrated in Figure 12B and Figure 12C for connections.

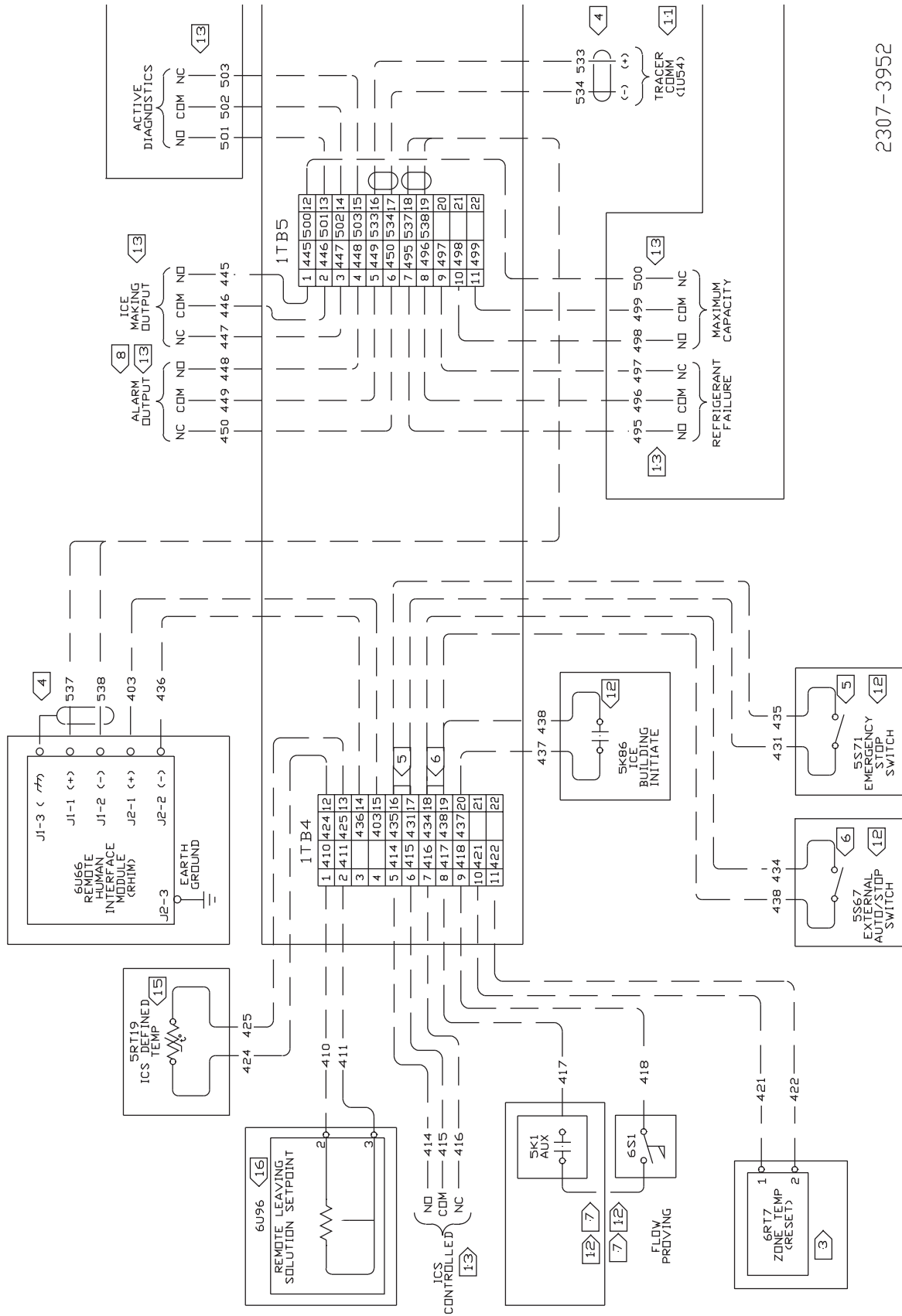

2307-3952

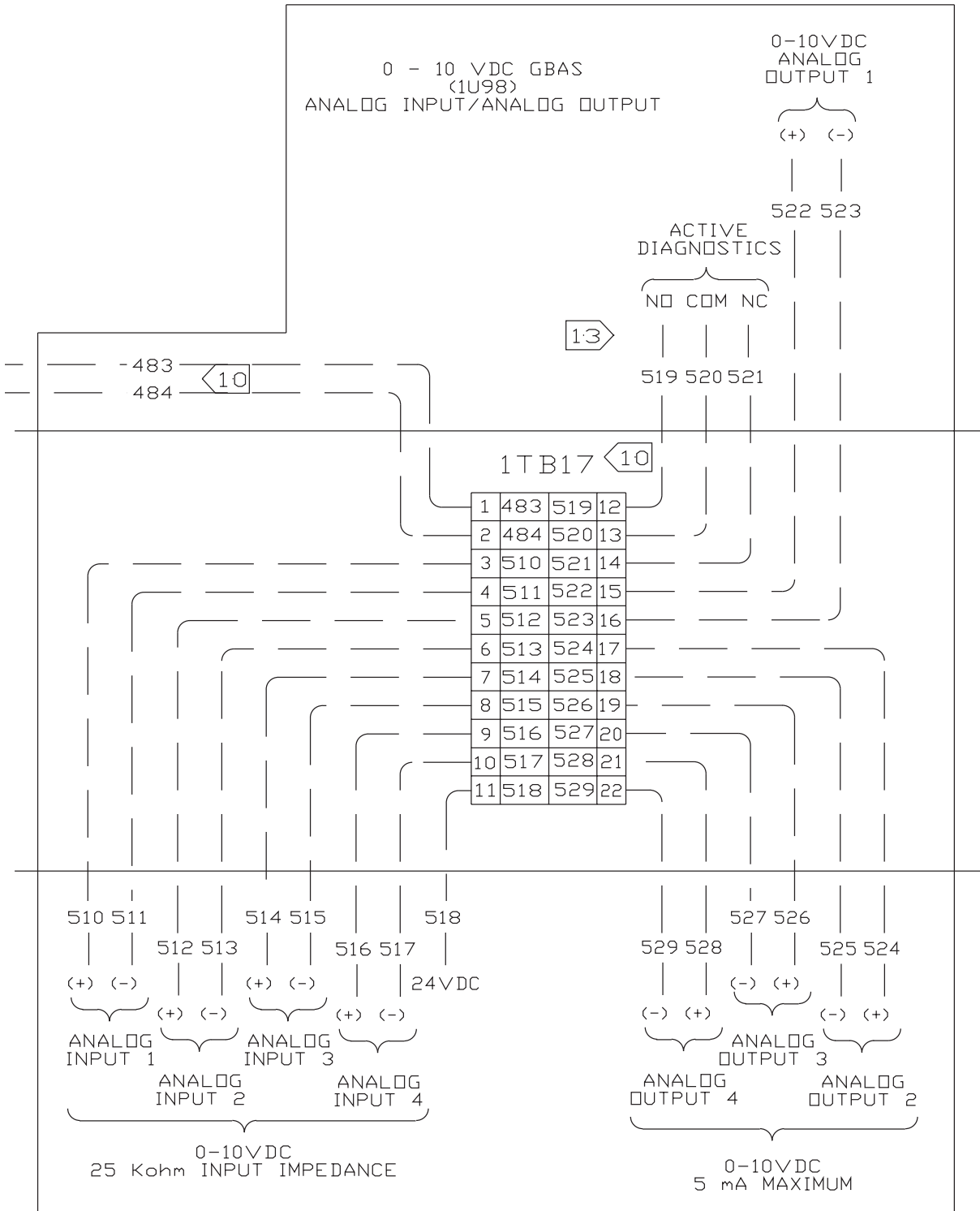

2307-3952

NOTES:

1. ALL WIRING AND COMPONENTS SHOWN DASHED TO BE SUPPLIED AND INSTALLED BY THE CUSTOMER IN ACCORDANCE WITH THE NATIONAL ELECTRICAL CODE (NEC), STATE AND LOCAL REQUIREMENTS. OUTSIDE THE UNITED STATES, OTHER COUNTRIES APPLICABLE NATIONAL AND/OR LOCAL REQUIREMENTS SHALL APPLY.
2. SEE CUSTOMER CONNECTION WIRE RANGE TABLE FOR ACCEPTABLE WIRE SIZES FOR CONNECTION TO MAIN UNIT TERMINAL BLOCK (1TB1) OR DISCONNECT SWITCH (1S14).
3. OPTIONAL 6RT7 SENSOR IS USED FOR ZONE TEMPERATURE RESET - USE BAYSENS017B OR EQUIVALENT.
4. WIRES ARE SHIELDED TWISTED PAIR.
5. REMOVE JUMPER (1TB4-16 AND 1TB4-17) WHEN FIELD SUPPLIED EMERGENCY STOP SWITCH (5S71) IS INSTALLED.
6. REMOVE JUMPER (1TB4-18 AND 1TB4-19) WHEN FIELD SUPPLIED EXTERNAL AUTO/STOP SWITCH (5S67) IS INSTALLED.
7. INSTALL FLOW PROVING SWITCH (6S1) AND 5K1 AUXILIARY CONTACT.
8. ALARM OUTPUT SWITCHES AT ANY MANUAL RESET DIAGNOSTIC.
9. TERMINAL BLOCK 1TB16 AND ASSOCIATED WIRING REQUIRED WITH GBAS 0-5VDC (1U51) OPTION. DEMAND LIMIT CONTACTS (5K89) TO BE PROVIDED BY CUSTOMER.
10. TERMINAL BLOCK 1TB17 AND ASSOCIATED WIRING REQUIRED WITH GBAS 0-10VDC (1U98) OPTION. DEMAND LIMIT CONTACTS (5K89) TO BE PROVIDED BY CUSTOMER.
11. WIRES 533 AND 534 ARE REQUIRED WITH THE BAS/NETWORK COMMUNICATION MODULE (1U54) OPTION.
12. CONTACTS RATED 12 mA @ 24VDC MINIMUM.
13. CONNECT TO 24VAC CLASS 2 CIRCUITS ONLY.
14. WHEN HEAT TAPE IS INSTALLED, CUSTOMER MUST PROVIDE 115VAC POWER FOR 60HZ UNITS OR 240VAC POWER FOR 50HZ UNITS TO 1TB12-L1 AND 1TB12-L2.
15. 5RT19 ICS DEFINED TEMPERATURE SENSOR - USE BAYSENS016A, BAYSENS017B OR EQUIVALENT.
16. OPTIONAL REMOTE LEAVING SOLUTION SETPOINT POTENTIOMETER (6U96). USE BAYSENS030A OR EQUIVALENT.

2307-3952

System Pre-Start Procedures

Use the checklist provided below in conjunction with the “General Unit Requirement” checklist” to ensure that the unit is properly installed and ready for operation. Be sure to complete all of the procedures described in this section before starting the unit for the first time.

- [] Turn the field supplied disconnect switch, located upstream of the unit, to the “Off” position.

WARNING **Hazardous Voltage!**

Disconnect all electric power, including remote disconnects before servicing. Follow proper lockout/tagout procedures to ensure the power can not be inadvertently energized. Failure to disconnect power before servicing could result in death or serious injury.

- [] Turn the “System” selection switch (at the Remote Panel) to the “Off” position and the “Fan” selection switch (if applicable) to the “Auto” or “Off” position.
- [] Check all electrical connections for tightness and “point of termination” accuracy.
- [] Verify that the condenser airflow will be unobstructed.
- [] Check the condenser fan blades. Ensure they rotate freely within the fan orifices and are securely fastened to the fan motor shaft.
- [] Verify that all compressor service valves, discharge service valves, and liquid line service valves are back seated on each circuit.

CAUTION **Compressor Damage!**

Do not allow liquid refrigerant to enter the suction line. Excessive liquid accumulation in the liquid lines may result in compressor damage.

Compressor service valves must be fully opened before start-up (suction, discharge, liquid line, and oil line).

Failure to fully open valves prior to start-up may cause compressor failure due to lack of refrigerant and/or oil flow.

- [] Inspect the interior of the unit for tools and debris.
- [] Fill the chilled water system.
- [] Vent the chilled water system at the highest points in the system. Vent the air out of the chiller barrel by opening the vent, located on the top of the chiller barrel. Close the vent when the chiller barrel is full of water.
- [] Once the system has been filled, inspect the entire chilled water piping system for leaks. Make any necessary repairs before proceeding.

Note: To avoid possible equipment damage, do not use untreated or improperly treated system water.

WARNING

Live Electrical Components!

During installation, testing, servicing and troubleshooting of this product, it may be necessary to work with live electrical components. Have a qualified licensed electrician or other individual who has been properly trained in handling live electrical components perform these tasks. Failure to follow all electrical safety precautions when exposed to live electrical components could result in death or serious injury.

Voltage Imbalance

Excessive three phase voltage imbalance between phases will cause motors to overheat and eventually fail. The maximum allowable voltage imbalance is 2%. Measure and record the voltage between phases 1, 2, and 3 and calculate the amount of imbalance as follows:

$$\% \text{ Voltage Imbalance} = 100 \times \frac{AV - VD}{AV} \text{ where;}$$

$$AV (\text{Average Voltage}) = \frac{\text{Volt 1} + \text{Volt 2} + \text{Volt 3}}{3}$$

V1, V2, V3 = Line Voltage Readings

VD = Line Voltage reading that deviates the farthest from the average voltage.

Example: If the voltage readings of the supply power measured 221, 230, and 227, the average volts would be:

$$\frac{221 + 230 + 227}{3} = 226 \text{ Avg.}$$

VD (reading farthest from average) = 221

The percentage of Imbalance equals:

$$100 \times \frac{226 - 221}{226} = 2.2\%$$

The 2.2% imbalance in this example exceeds the maximum allowable imbalance of 2.0%. This much imbalance between phases can equal as much as a 20% current imbalance with a resulting increase in motor winding temperatures that will decrease motor life. If the voltage imbalance is over 2%, notify the proper agencies to correct the voltage problem before operating this equipment.

Scroll Compressor Current Imbalance

Typically, current imbalance is associated with loss in motor efficiency, higher operating motor temperature, loss of performance and reliability.

With the designs of specialized motors such as those used in the Trane scroll compressor, operating temperature, efficiency, performance, and reliability has been taken into account in the total performance of the compressor.

Current imbalance in a scroll compressor can typically vary from 4 to 15 percent with balanced line voltage. This imbalance occurs because not all of the winding turns see the same amount of stator iron. The variance of iron within the motor is to accommodate design requirements for motor cooling and oil return.

System Pre-Start Procedures

At low operating voltage and high operating load, the imbalance may be around 4 percent. At high operating voltage and low operating load, the imbalance may be as high as 15 percent.

If an imbalance situation is suspected within the compressor (current draw unequal between phases) and the line voltage imbalance does not exceed 2 percent;

1. Turn the field supplied disconnect switch, located upstream of the unit to the "Off" position.

WARNING **Hazardous Voltage!**

Disconnect all electric power, including remote disconnects before servicing. Follow proper lockout/tagout procedures to ensure the power can not be inadvertently energized. Failure to disconnect power before servicing could result in death or serious injury.

2. Disconnect the compressor leads at the compressor terminals.
3. Measure the resistance of the compressor windings at the compressor terminals.

The actual resistance measured across each winding is not as important as the amount of variation between the windings. The actual resistance measured may vary due to the accuracy of the meter, rounding off of the resistance readings, and the amount of resistance between the meter leads and the compressor terminals.

Since the amount of copper in each winding is very consistent, the variance between the windings should not exceed 7 percent.

Example: Typical 10 Ton, 460 volt, 60 Hz compressor has a winding resistance of 1.44 to 1.09 Ohms.

Electrical Phasing

Unlike traditional reciprocating compressors, scroll compressors are phase sensitive. Proper phasing of the electrical supply to the unit is critical for proper operation and reliability.

The compressor motor is internally connected for clockwise rotation with the incoming power supply phased as A, B, C.

Proper electrical supply phasing can be quickly determined and corrected before starting the unit by using an instrument such as an Associated Research Model 45 Phase Sequence Indicator and following the steps below:

WARNING **Hazardous Voltage!**

Disconnect all electric power, including remote disconnects before servicing. Follow proper lockout/tagout procedures to ensure the power can not be inadvertently energized. Failure to disconnect power before servicing could result in death or serious injury.

HIGH VOLTAGE IS PRESENT AT TERMINAL BLOCK 1TB1 OR UNIT DISCONNECT SWITCH 1S14.

- [] Turn the field supplied disconnect switch that provides power to terminal block 1TB1 or to the unit mounted disconnect switch 1S14 to the "Off" position.
- [] Connect the phase sequence indicator leads to terminal block 1TB1 or to the unit mounted disconnect switch 1S14 as follows;

Black (phase A)	to	L1
Red (phase B)	to	L2
Yellow (phase C)	to	L3

- [] Close the disconnect switch or circuit protector switch that provides the supply power to the unit's terminal block 1TB1 or the unit mounted disconnect switch 1S14.
- [] Observe the ABC and CBA phase indicator lights on the face of the sequencer. The ABC indicator light will glow if the phase is ABC. If the CBA indicator light glows, open the disconnect switch or circuit protection switch and reverse any two power wires.
- [] Restore the main electrical power and recheck the phasing. If the phasing is correct, open the disconnect switch or circuit protection switch and remove the phase sequence indicator.

System Start-Up

Sequence of Operation

Chiller Control for Comfort Applications

The CGM controls the leaving solution temperature (LST) to within an adjustable setpoint using deadband control. The CGM monitors the LST sensor and determines how far away the temperature is from the leaving solution setpoint (LSS). The compressors are staged On/Off depending on where the LST is within the control deadband.

Deadband Calculation

The rate at which capacity stages are added or subtracted is determined by a control algorithm. The CGM control deadband for comfort applications is a calculated value based upon the control response setpoint, the difference between LSS and LST, the number of capacity steps, the design delta temperature (DDT) of the system, and the number of capacity steps. The minimum comfort deadband is 1 degree F. The maximum comfort deadband above or below the LSS is 10 F for a two stage unit and 5°F for a 4 stage unit.

When the LST is inside the control deadband, the calculation is cleared and no response is initiated. When the LST is outside the deadband and the calculated control algorithm value equals 1, a capacity add command is initiated. Conversely, when the value of the control algorithm equals -1, a capacity subtract command is initiated. Once a capacity add or subtract command is given and a change in the compressor staging has been detected, the value of the control algorithm is reset to 0.

Chiller Freeze Protection

The CGM prevents evaporator fluid from freezing by utilizing two separate algorithms. One is the evaporator limit control algorithm which stages compressors "Off" if violated and the other is the evaporator freeze protection algorithm which activates auto/manual diagnostics if violated. The freeze protection function will always operate as long as the unit is in the Auto mode for both normal cooling applications and/or ice building modes. A manual reset diagnostic will occur if all compressors are shut off due to a freeze protection violation.

The evaporator limit control integrator (ELCI) algorithm calculates a value based upon the low solution temperature cutout setpoint and the leaving solution temperature. When the value for ELCI drops below -1, the unit control will reduce the chiller capacity by staging down and/or inhibiting a compressor from operation. After each capacity subtract command from the capacity control algorithm is issued, ELCI is increased by 1 and retained. The ELCI is set to 0 any time the leaving solution temperature is greater than or equal to the low solution temperature cutout (LSC) + 3°F. Compressors will be prevented from operating until the leaving solution temperature (LST) is 4°F above the LSC.

If Pumpdown is enabled and a subtract command is issued, the circuit will be allowed to pumpdown.

If HGBP is enabled (Pumpdown is disabled) and a subtract command is sent by the ELCI, HGBP operation will be initiated before the last compressor is turned "Off". Once HGBP has been initiated, all subtract commands sent by the ELCI will be ignored. If the Leaving Solution Temperature (LST) is less than the Low Solution Cutout (LSC) + 1°F, HGBP is either prevented from operating or turned "Off".

Evaporator Freeze Protection Diagnostic

The evaporator freeze protection integrator (EFZ) will start integrating when the leaving solution temperature or entering solution temperature is less than the low solution temperature cutout setpoint. Once EFZ integrates up to 30 Sec, the following diagnostics will occur:

1. If all compressors are off, an auto diagnostic will occur. All of the compressors will be prevented from operating until the LST and/or EST is 4°F greater than the LSC. Once the LST and/or EST is 4°F above the LSC, the unit will allow normal unit operation.
2. If any compressors are "On", a manual diagnostic will occur. All of the compressors will be shutdown and locked out due to the violation of the evaporator freeze protection.

Sequence of Operation

Chiller Control for Ice Building Mode

The CGM provides Ice Building control when a customer provided field installed binary input is connected to the CGM or requested by Tracer (TCI only).

Ice Building can be activated by:

- Closing the customer provided field installed remote device, or
- Ice building requested by Tracer (TCI only), provided;
- Ice machine option is installed, and
- Ice building is enabled through the Human Interface Module

The optional Ice building machine has two ice building modes:

1. One Time Ice Build Mode
Once the ice building mode is initiated, the unit will run fully loaded until the entering solution temperature (EST) equals the ice building termination setpoint (IBTS). After the IBTS is reached, the unit will transition into the "Ice Building Complete" mode and turn all compressors "Off" and the solution pump "Off" (if pump mode is in "Auto"). The unit will remain in the ice build complete status until the unit is cycled out of the "Ice Building" mode.
2. Continuous Ice Build Mode
Once the ice building mode is initiated, the unit will run fully loaded until the EST equals the IBTS. After the EST reaches the IBTS, the unit will transition into the "Ice Rebuild Delay" mode and turn all compressors "Off" and the solution pump "Off" (if pump mode is in "Auto"). The unit will remain in the ice rebuild delay status until the Ice Rebuild Delay Timer (IRDT) expires. Once the IRDT time expires the unit will transition to the "Loop Stabilization" state and turn the solution pump "On" (if pump mode is in "Auto"). Once the loop stabilization timer has expired, the unit will transition into the ice building mode and will run fully loaded until the IBTS is reached. After the IBTS is reached, the unit will transition into the "Ice Rebuild Delay" mode again. The unit will continue to cycle through the ice building, ice rebuild delay and loop stabilization states until the unit is cycled out of the ice building mode or the continuous ice building mode is changed to the one time ice building mode.

System Start-Up

Ice Building can be terminated by:

- Opening the customer provided field installed remote device, or
- Ice building stopped from ICS communications.

If at any time the unit is switched from the Ice Building mode to normal comfort operation, the unit will transition to ice building complete status and stage all operating compressors "Off".

Sequence of Operation

Chiller Control for Process Applications

Process applications are characterized as having fast changes in load and these loads are not adequately controlled with the same scheme used for comfort applications. To provide better control of these dynamic loads, a Proportional + Integral "control to setpoint" (as opposed to "control to deadband") control strategy is used. System reliability is inversely proportional to compressor cycle rates so reliability is the driving factor for determining maximum cycle rate which ultimately translates into cycle-to-cycle leaving solution temperature swings.

To provide stable capacity control, a 1 minute minimum time between compressor starts is required. The control will determine an estimate of instantaneous load based on error from setpoint for the leaving solution temperature and cycle the appropriate compressor stage to best match the calculated load.

Determining instantaneous error:

$$\text{Error} = \text{Chiller Solution Temp} - \text{Chiller Solution Setpoint.}$$

PI Control Calculation:

The CGM calculates the Load Value by applying PI calculations to the instantaneous error value. The Load Value consists of an integer part and a fractional part. The integer part represents which compressor stages are locked "On" and the fractional part represents the duty cycle required for the next higher compressor stage. For a 4 compressor unit, the Load Value will range from 0.0 to 4.0. For a 2 compressor unit, the Load Value will range from 0.0 to 2.0.

Duty Cycle Calculations calculate the duty cycle based on the calculated Load Value Fraction:

$$\text{On Time Seconds} = 3600 / 4 \times \text{Max Cycle Rate} \times (1 - \text{Load Value Fraction})$$

$$\text{Off Time Seconds} = 3600 / 4 \times \text{Max Cycle Rate} \times \text{Load Value Fraction}$$

Where Load Value Fraction = Fractional part of the calculated Load Value.

Sequence of Operation

Leaving Solution Reset (LSR)

Leaving Solution Reset (LSR) refers to the process of adjusting the Leaving Solution Setpoint (LSS) based on an external temperature.

When the optional Leaving Solution Reset (LSR) feature is used, the CGM will automatically adjust the LSS in response to a temperature change from one of three different temperature sensors:

1. Zone Temperature sensor
2. Outside Air Temperature sensor
3. Entering Solution Temperature sensor.

The reset temperature value (Start Temperature), to start resetting the Leaving Solution Setpoint (LSS) and the maximum amount of reset to be applied to the LSS is programmable through the Human Interface. The reset amount applied to the LSS is a linear calculation between the Start Temperature and the End Temperature. After the reset amount has been calculated, it is added to the Leaving Solution Setpoint to create the Leaving Solution Reset Setpoint. If the solution temperature is above the selected Start Temperature, the reset amount is zero. If the solution temperature is below the End Temp, the maximum amount of reset is applied. For reset type 'None', the amount of reset is zero. Refer to the appropriate reset type in Table 5-1 for reset schedules.

System Start-up

Zone Temp Reset:

- If Zone Temperature is above the Start Temp, or if Zone Temperature Sensor has failed, calculated reset amount is zero (0).
- If Zone Temperature is equal or below the End Temp, calculated reset amount is equal to selected Max Amount.
- If Zone Temperature is between the Start Temp and the End Temp,

$$\text{calculated reset amount} = \frac{\text{Max Amount}}{(\text{ZR Start Temp} - \text{ZR End Temp})} * (\text{ZR Start Temp} - \text{Zone Temp})$$

Outside Air Temp Reset

- If Outside Air Temperature is above the Start Temp, or if Outside Air Temperature Sensor has failed, calculated reset amount is zero (0).
- If Outside Air Temperature is equal or below the End Temp, calculated reset amount is equal to selected Max Amount.
- If Outside Air Temperature is between the Start Temp and the End Temp,

$$\text{calculated reset amount} = \frac{\text{Max Amount}}{(\text{OA Start Temp} - \text{OA End Temp})} * (\text{OA Start Temp} - \text{Outside Air Temp})$$

Entering Solution Temp Reset

- If (EST - LST) is above the Start Temp, or if either Entering Solution or Leaving Temperature Sensor has failed, calculated reset amount is zero (0).
- If (EST - LST) is equal or below the End Temp, calculated reset amount is equal to selected Max Amount.
- If (EST - LST) is between the Start Temp and the End Temp,

$$\text{calculated reset amount} = \frac{\text{Max Amount}}{(\text{ES Start Temp} - \text{ES End Temp})} * (\text{ES Start Temp} - (\text{EST} - \text{LST}))$$

Determine the Active Leaving Solution Setpoint (LSS)

LSS = ALSS + calculated reset amount.

Where:

ALSS is Arbitrated Leaving Solution Setpoint

LSS is Active Leaving Solution Setpoint

System Start-Up

Table 8A
Chilled Solution Reset Schedule based on Zone Temperature

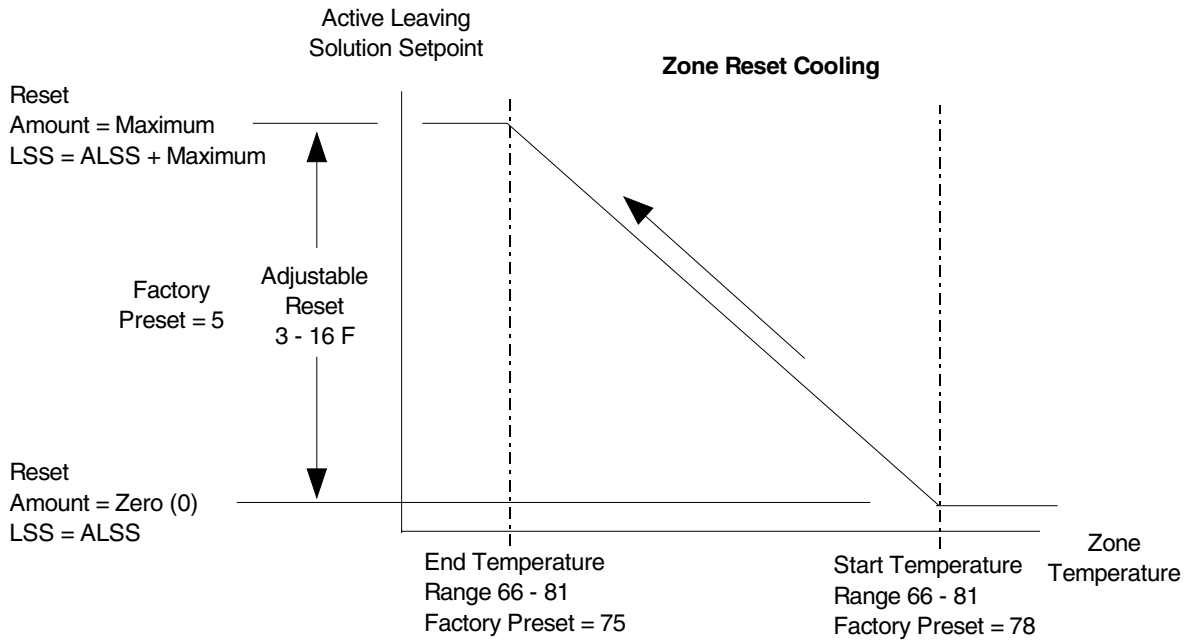
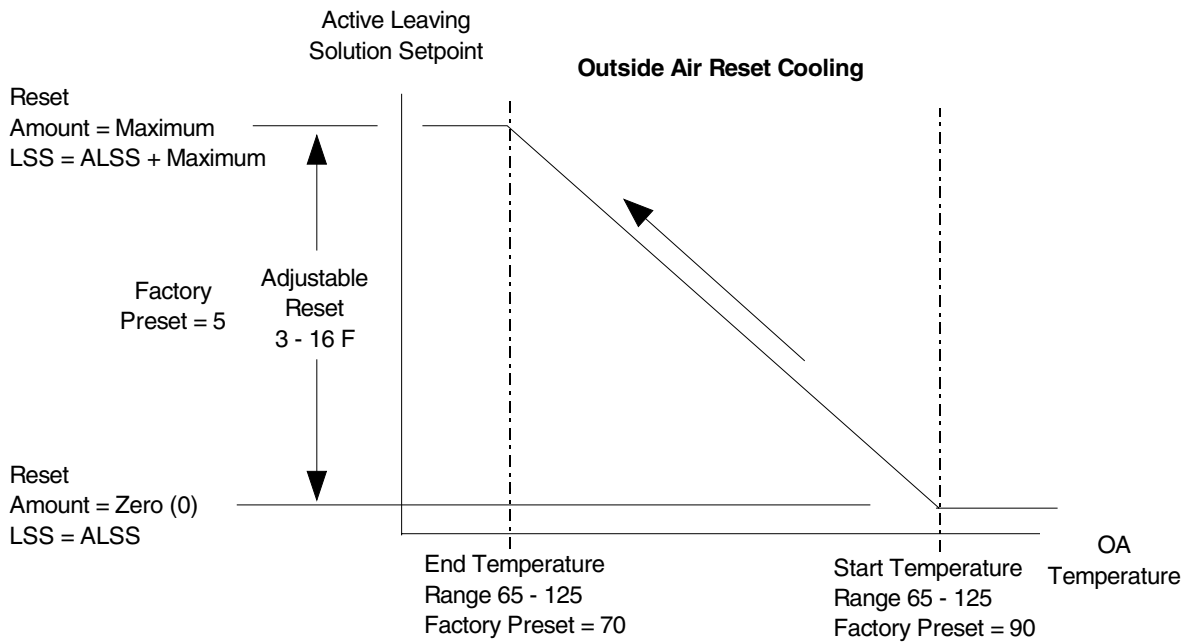

Table 8B
Chilled Solution Reset Schedule based on Outside Air Temperature



System Start-Up

Table 8C

Chilled Solution Reset Schedule based on Entering Solution Temperature

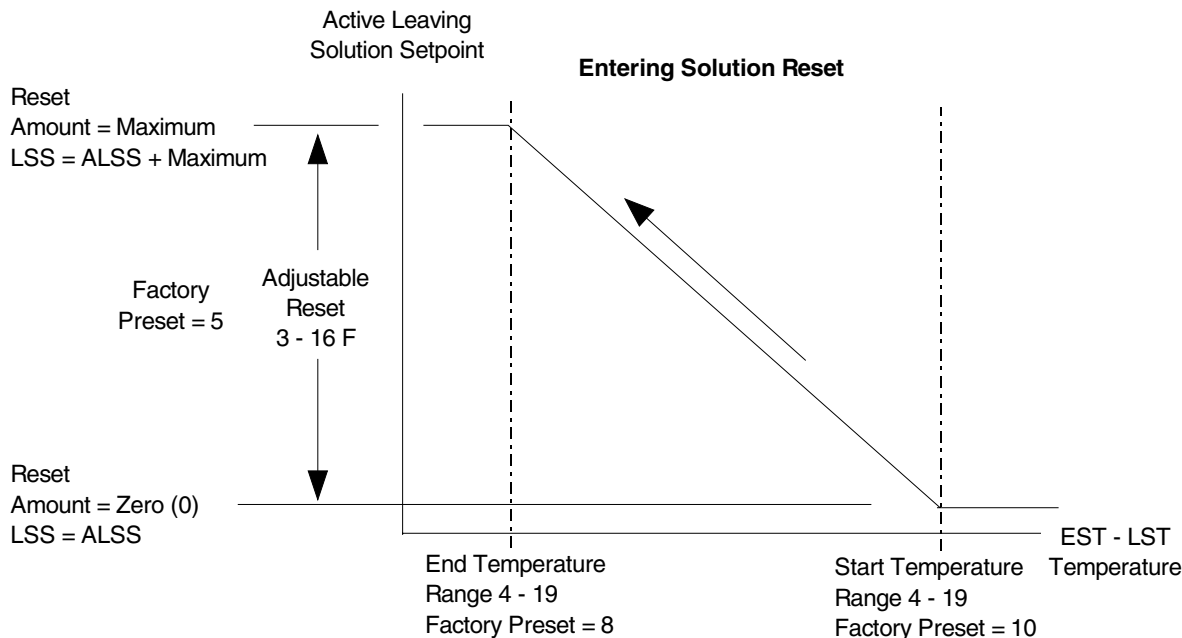

Sequence of Operation

Lead/Lag (Standard)

When Lead-Lag is enabled, for each capacity add request, the CGM will begin sequencing the compressors “On” that have:

- a. the least number of starts; or,
- b. the least run time (if number of starts are equal)

At each capacity subtract request, the CGM will begin sequencing the compressors “Off” that have:

- a. the most run time; or,
- b. the least number of starts (if more than one compressor has the same run time)

If a compressor is locked out for any reason when a capacity add request occurs, the next available compressor which meets the specified criteria will be started.

If a compressor can not be turned “Off” due to the minimum “On Time”, the next compressor which meets the specified criteria will be turned “Off”.

On dual circuit units, as the first two capacity add requests are initiated, one compressor on each circuit will start before any additional compressors on any circuit is started. When staging down from three compressor stages to two compressor stages, the CGM will turn a compressor “Off” on the circuit that has the most compressors operating.

The Lead/Lag function is ignored (treated as disabled) when the Hot Gas Bypass option is installed and enabled.

When the UCM is powered up (after a power loss), or any time the compressor’s start time and run time are equal, the number one (Lead) designated compressor will be the first “On” and the number two (lag) designated compressor will be the first “Off” on single circuit units (20 - 30 Tons).

For dual circuit units (40 through 60 Tons), the “On” sequence will be A-C-B-D and the “Off” sequence will be D-B-C-A under the previously described conditions. Refer to Figure 16 for compressor locations.

Sequence of Operation

Hot Gas Bypass (HGBP)

The Hot Gas Bypass (HGBP) option prevents compressor short cycling. The HGBP option can only be installed on circuit #1. With HGBP installed and enabled, the unit will always stage the circuit #1 compressors “On” first, if operable and stage them “Off” last. Hot Gas Bypass is never initiated when staging compressors “On” (adding capacity), only when staging compressors “Off”.

HGBP is initiated when the last compressor on circuit #1 is operating, and the capacity control algorithm generates a subtract command.

Sequence of Operation

Condenser Fan Control

The CGM condenser fan control logic is dependent on the number of compressors operating per circuit and the saturated condensing temperature. Fan logic is not initiated until the low ambient start time has elapsed.

The condenser fan contactors, located in the unit control panel, initiate fan operation when energized. Refer to Figure 15 for the condenser fan locations and fan contactor designators.

System Start-Up

Sequence of Operation

Low Ambient Dampers

Low Ambient Dampers are available as a factory installed option or can be field-installed. Dampers are used to extend the operation of these units from the standard operational temperatures to a minimum of 0°F without hot gas bypass or 10°F with hot gas bypass. (These values apply when wind speed across the condenser coil is less than 5 m.p.h.). If typical wind speeds are higher than 5 m.p.h., a wind screen around the unit may be required. By restricting the airflow across the condenser coils, saturated condensing temperatures can be maintained as the ambient temperatures change.

The low ambient damper actuator controls damper modulation for each refrigerant circuit in response to saturated condensing temperature.

Chilled Water Circulating Pump

Once the system has been filled, complete the following chilled water system start-up procedures.

1. Turn the 115 volt control circuit switch 1S1 and the 24 volt control circuit switch 1S70 located in the unit control panel to the "Off" position.
2. Turn the main power disconnect switch and the control circuit disconnect switch (5S1), for the solution pump, to the "On" position.
3. Close the main power disconnect switch or circuit protector switch that provides the supply power to the unit's terminal block 1TB1 or the unit mounted disconnect switch 1S14. The unit mounted disconnect switch (1S14), if applicable, must be closed.
4. Turn the 24 volt control circuit switch 1S70 located in the unit control panel to the "On" position.

Note: To prevent the compressors from starting, leave the 115 volt control circuit switch "Off".

5. Open the Human Interface access door, located in the unit control panel, and press the SERVICE MODE key to display the first service screen. Refer to the latest edition of the Trouble Shooting Guide for the SERVICE TEST screens and programming instructions.
6. Once the configuration for the pump is complete, press the NEXT key until the LCD displays the "Start test in ___Sec." screen. Press the + key to designate the delay before the test is to start. This service test will begin after the TEST START key is pressed and the delay designated in this step has elapsed. Press the ENTER key to confirm this choice.

WARNING Rotating Components!

During installation, testing, servicing and troubleshooting of this product it may be necessary to measure the speed of rotating components. Have a qualified or licensed service individual who has been properly trained in handling exposed rotating components, perform these tasks. Failure to follow all safety precautions when exposed to rotating components could result in death or serious injury.

7. Press the TEST START key to start the test. Remember that the delay designated in step 7 must elapse before the pump will begin to operate.

Note: Pump operation is dependent upon proper solution flow proving switch operation. Please see section titled "Loss-Of Flow Protection: under General Information for details.

8. To balance the flow through the evaporator, adjust the flow rates between the minimum and maximum values given in Table 9. Flow rates above or below these values can cause equipment damage or improper unit operation.
9. Check the flow device (if applicable) on the evaporator outlet piping to ensure it opens and closes properly.
10. Measure the evaporator water pressure drop at the system pressure gauge(s). Compare the readings to the pressure drop values given in Figure 13.

Note: Evaporator pressure drop is an approximation and is to be used as a tool to estimate flow rate and as an aid to waterside system piping design. If an accurate measurement of flow is required, a flow meter must be installed in the system.

Ethylene Glycol Adjustment Factor

The addition of ethylene glycol to the chilled water system reduces unit capacity. To determine the pressure drop of a glycol solution system, obtain the pressure drop adjustment factor from the chart in Figure 14 and multiply it times the pressure drop of a water system without glycol, i.e:

$$\text{Glycol sP} = \text{H}_2\text{O sP} \times \text{Adjustment Factor.}$$

Table 9
Evaporator Data for C20 through C60 Units

Unit Size	Water Volume		Minimum Flow Rate		Maximum Flow Rate	
	gal	litre	gpm	litre/s	gpm	litre/s
C20	11.7	44	24	1.5	72	4.5
C25	10.7	40	30	1.9	90	5.7
C30	16.3	62	36	2.3	108	6.8
C40	13.8	52	48	3	144	9.1
C50	21	79	60	3.8	180	11.3
C60	37.8	143	72	4.5	216	13.6

System Start-Up

Figure 13
Evaporator Water-Pressure Drop for CGAF-C20 Through C60 Units (English)

Note 1 - Factor to convert "Feet of Water" to "Lbs. per Sq. Inch" (PSI): 2.3 Feet of Water = 1 PSI

Evaporator Pressure Drops

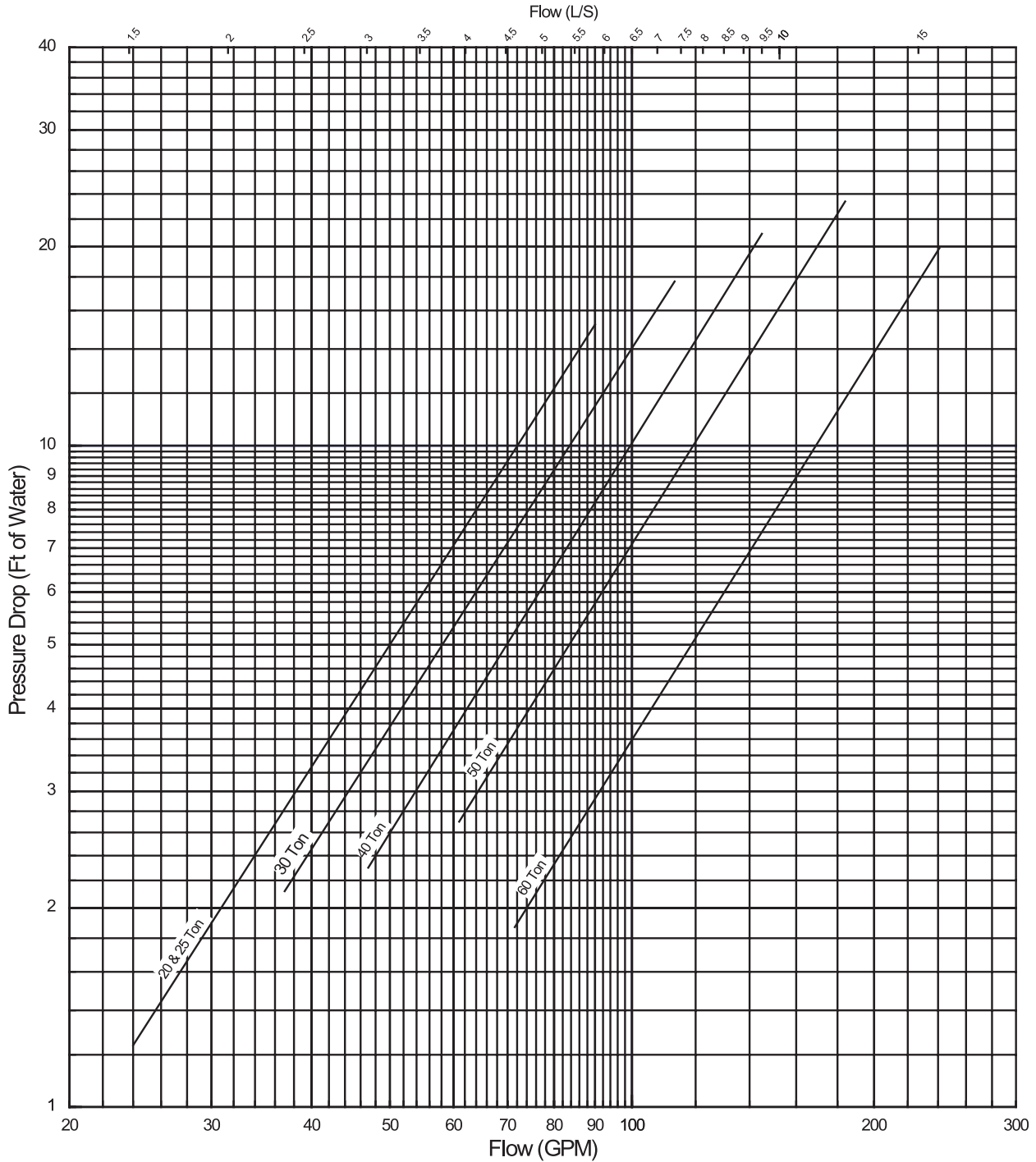

System Start-Up

Figure 14

Performance Adjustments and Solution Freezing Points
(Use Only When Leaving Brine Temperature is Between 40°F & 50°F)

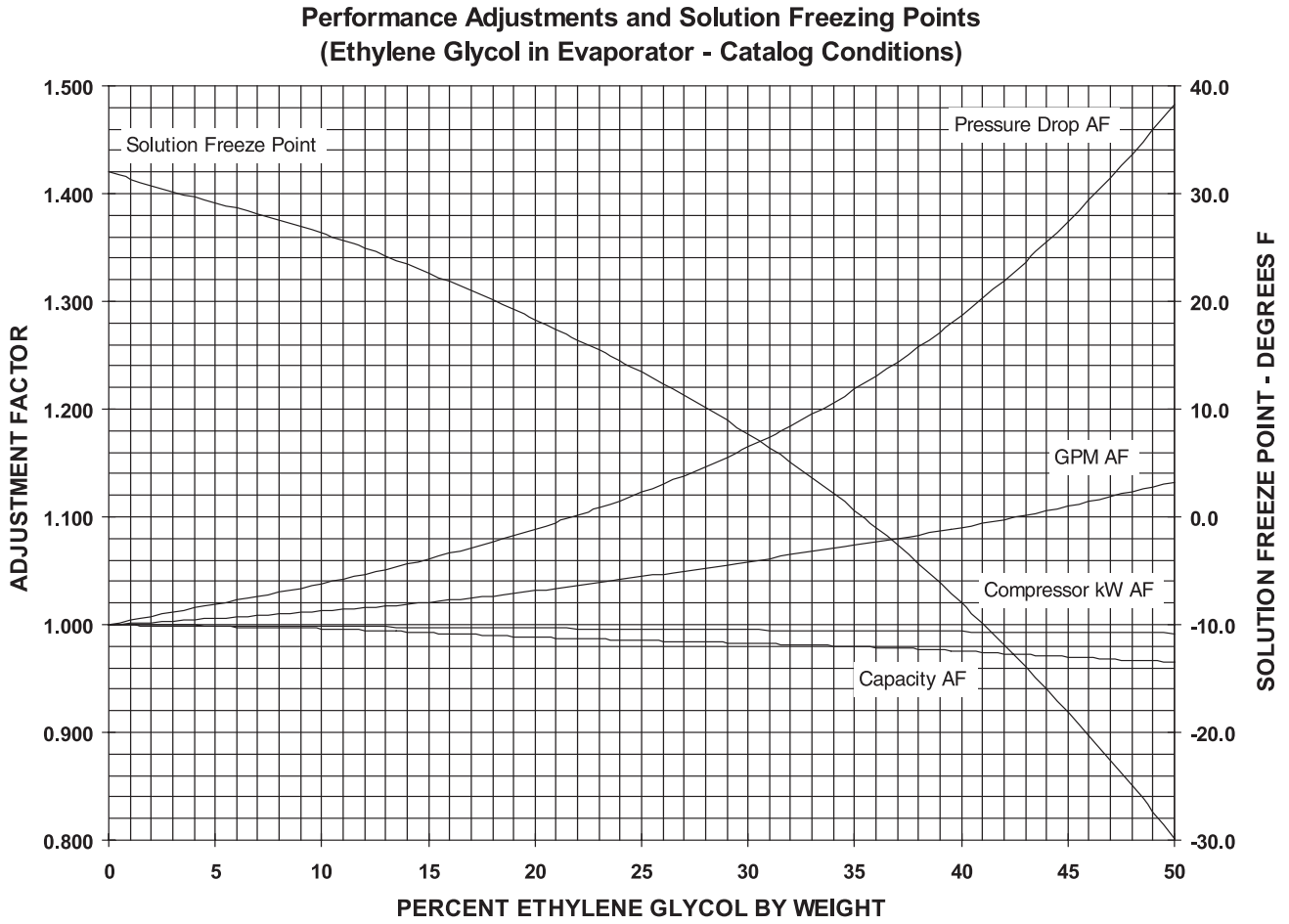

System Start-Up

Verifying Proper Fan Rotation

1. Close the main power disconnect switch or circuit protector switch that provides the supply power to the unit's terminal block 1TB1 or the unit mounted disconnect switch 1S14.
2. Open the Human Interface access door, located in the unit control panel, and press the SERVICE MODE key to display the first service screen. Refer to the latest edition of the CG-SVP manual for the SERVICE TEST screens and programming instructions.
3. Use the Human Interface to program the condenser fans for operation by scrolling through the displays. All of the condenser fans can be programmed to be "On", if desired. Verify proper fan rotation for VFD's with bypass.

Refer to Figure 15 for the condenser fan locations and designations.

4. Once the configuration for the Fans is complete, press the NEXT key until the LCD displays the "Start test in ___Sec." screen. Press the + key to designate the delay before the test is to start. This service test will begin after the TEST START key is pressed and the delay designated in this step has elapsed. Press the ENTER key to confirm this choice.



WARNING Rotating Components!

During installation, testing, servicing and troubleshooting of this product it may be necessary to measure the speed of rotating components. Have a qualified or licensed service individual who has been properly trained in handling exposed rotating components, perform these tasks. Failure to follow all safety precautions when exposed to rotating components could result in death or serious injury.

5. Press the TEST START key to start the test. Remember that the delay designated in step 4 must elapse before the fans will begin to operate.
6. Check the supply fan and the exhaust fans (if equipped) for proper rotation. The direction of rotation is indicated by an arrow on the fan housings. Check the condenser fans for clockwise rotation when viewed from the top.

If all of the fans are rotating backwards;

- a. Press the STOP key at the Human Interface Module in the unit control panel to stop the fan operation.
- b. Open the field supplied disconnect switch upstream of the unit. Lock the disconnect switch in the open position while working at the unit.



WARNING Hazardous Voltage!

Disconnect all electric power, including remote disconnects before servicing. Follow proper lockout/tagout procedures to ensure the power can not be inadvertently energized. Failure to disconnect power before servicing could result in death or serious injury.

- c. Interchange any two of the field connected main power wires at the unit terminal block 1TB1 or the factory mounted disconnect switch 1S14.

Note: Interchanging "Load" side power wires at the fan contactors will only affect the individual fan rotation. Ensure that the voltage phase sequence at the main terminal block 1TB1 or the factory mounted disconnect switch 1S14 is ABC as outlined in the "Electrical Phasing" section.

If some of the fans are rotating backwards;

- a. Press the STOP key at the Human Interface Module in the unit control panel to stop the fan operation.
- b. Open the field supplied disconnect switch upstream of the unit. Lock the disconnect switch in the open position while working at the unit. As indicated by warning on previous page.
- c. Interchange any two of the fan motor leads at the contactor for each fan that is rotating backwards.

Compressor Start-Up

1. Ensure that the main power disconnect switch and the control power disconnect switch for the "System Solution Pump" is "On".
2. Before closing the main power disconnect switch for the unit, ensure that the compressor discharge service valve and the liquid line service valve for each circuit is back seated.



CAUTION Compressor Damage!

Do not allow liquid refrigerant to enter the suction line. Excessive liquid accumulation in the liquid lines may result in compressor damage.

Compressor service valves must be fully opened before start-up (suction, discharge, liquid line, and oil line).

Failure to fully open valves prior to start-up may cause compressor failure due to lack of refrigerant and/or oil flow.

3. Remove the protective plastic coverings that shipped over the compressors.
4. Check the compressor oil levels. The oil level in each manifolded set of compressor sight glasses should be equally 1/2 to 3/4 full when they are "Off".
5. Check the condenser coils. They should be clean and the fins should be straight. Straighten any bent coil fins with an appropriate sized fin comb.
6. Turn the main power disconnect switch or circuit protector switch that provides the supply power to the unit's terminal block 1TB1 or the unit mounted disconnect switch 1S14 to the "On" position.
7. Turn the 24 volt control circuit switch 1S70 to the "On" position.

System Start-Up

Figure 15
Condenser Fan Locations

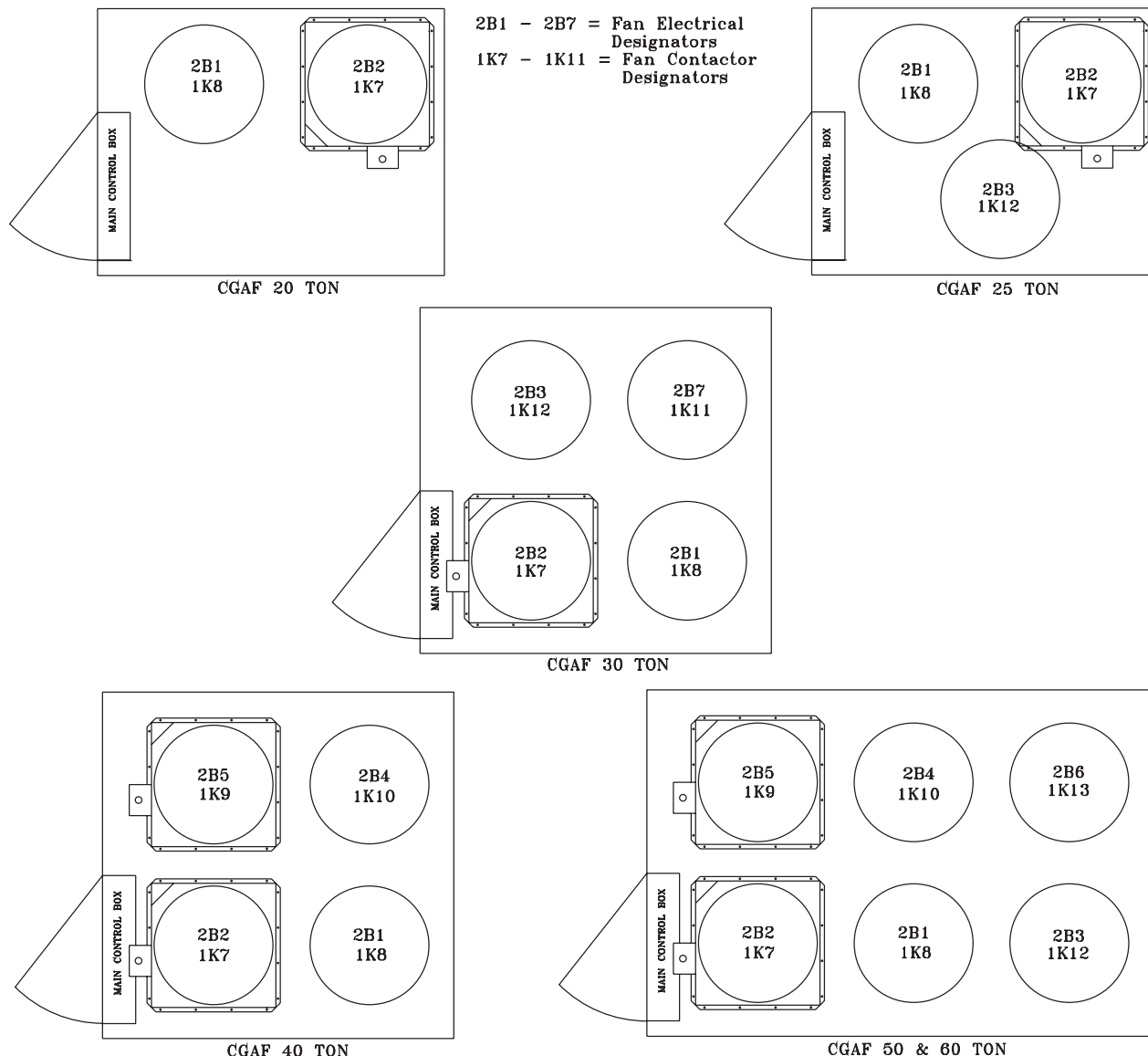

8. Open the Human Interface access door, located in the unit control panel, and press the SERVICE MODE key to display the first service screen. Refer to the latest edition of the Trouble Shooting Guide for the SERVICE TEST screens and programming instructions.

9. Program the following system components for operation by scrolling through the displays;

20 through 30 Ton

- Compressor 1A (On)
- Compressor 1B (Off)
- Condenser Fans (On)
- Solution Pump (On)

40 through 60 Ton

- Compressor 1A (On)
- Compressor 1B (Off)
- Compressor 2A (Off)
- Compressor 2B (Off)
- Condenser Fans (On)
- Solution Pump (On)

Note: Pump operation is dependent upon proper solution flow proving switch operation. Please see section titled "Loss-Of-Flow Protection" under General Information for details.

10. Attach a set of service gauges onto the suction and discharge gauge ports for each circuit. Refer to Figure 16 for the various compressor locations.

11. Once the configuration for the components is complete, press the NEXT key until the LCD displays the "Start test in __Sec." screen. Press the + key to designate the delay before the test is to start. This service test will begin after the TEST START key is pressed and the delay designated in this step has elapsed. Press the ENTER key to confirm this choice.



WARNING Rotating Components!

During installation, testing, servicing and troubleshooting of this product it may be necessary to measure the speed of rotating components. Have a qualified or licensed service individual who has been properly trained in handling exposed rotating components, perform these tasks. Failure to follow all safety precautions when exposed to rotating components could result in death or serious injury.

12. Turn the 115 volt control circuit switch 1S1 "On".
13. Press the TEST START key to start the test. Remember that the delay designated in step 11 must elapse before the system will begin to operate.
14. Once each compressor or compressor pair has started, verify that the rotation is correct. If a scroll compressor is rotating backwards, it will not pump and a loud rattling sound can be observed. Check the electrical phasing at the load side of the compressor contactor.

If the phasing is correct, before condemning the compressor, interchange any two leads to check the internal motor phasing. Refer to the illustration in Figure 17 for the compressor terminal identification. If the compressor runs backward for an extended period (15 to 30 minutes), the motor windings can over heat and cause the motor winding thermostats to open. This will cause a "compressor trip" diagnostic and stop the compressor.
15. Verify that the oil level in each compressor is correct. The oil level may be down to the bottom of the sightglass but should never be above the sightglass.
16. Press the STOP key at the Human Interface Module in the unit control panel to stop the compressor operation.
17. Repeat steps 8 through 16 for each compressor stage and the appropriate condenser fans.

Verifying Proper Refrigerant Charge

1. Attach a set of service gauges onto the suction line and liquid line gauge ports for each circuit. Refer to Figure 16 for the various compressor locations.
2. Open the Human Interface access door, located in the unit control panel, and press the SERVICE MODE key to display the first service screen. Refer to the latest edition of the Trouble Shooting Guide for the SERVICE TEST screens and programming instructions.
3. Program the following system components for the number 1 refrigeration circuit by scrolling through the displays;
 - Chilled Solution Pump (On)
 - All Compressors for each circuit (On)
 - Condenser Fans for each circuit (On)
 - Hot Gas Bypass (Disabled, if applicable)
 - Low Ambient Dampers (100%, if applicable)
4. Once the configuration for the components is complete, press the NEXT key until the LCD displays the "Start test in __Sec." screen. Press the + key to designate the delay before the test is to start. This service test will begin after the TEST START key is pressed and the delay des-

System Start-Up

ignated in this step has elapsed. Press the ENTER key to confirm this choice.



WARNING Rotating Components!

During installation, testing, servicing and troubleshooting of this product it may be necessary to measure the speed of rotating components. Have a qualified or licensed service individual who has been properly trained in handling exposed rotating components, perform these tasks. Failure to follow all safety precautions when exposed to rotating components could result in death or serious injury.

5. Press the TEST START key to start the test. Remember that the delay designated in step 4 must elapse before the system will begin to operate.
6. After all of the compressors and condenser fans for the number 1 circuit have been operating for approximately 30 minutes, observe the operating refrigerant pressures and measure the system superheat and subcooling.

The outdoor ambient temperature must be between 65°F and 105°F. When the temperatures are outside of these ranges, refer to Table 10 for the recommended refrigerant capacities.

Note: Do Not release refrigerant to the atmosphere! If adding or removing refrigerant is required, the service technician must comply with all Federal, State and local laws. Refer to general service bulletin MSCU-SB-1 (latest edition).

Subcooling

With the unit operating at "Full Circuit Capacity", acceptable subcooling ranges between 14°F to 22°F.

Measuring Subcooling

- a. At the liquid line service valve, measure the liquid line pressure. Using a Refrigerant 22 pressure / temperature chart, convert the pressure reading into the corresponding saturated temperature.
- b. Measure the actual liquid line temperature as close to the liquid line service valve as possible. To ensure an accurate reading, clean the line thoroughly where the temperature sensor will be attached. After securing the sensor to the line, insulate the sensor and line to isolate it from the ambient air.

Note: Glass thermometers do not have sufficient contact area to give an accurate reading.

- c. Determine the system subcooling by subtracting the actual liquid line temperature (measured in b) from the saturated liquid temperature (converted in a).

Superheat

The reliability and performance of the refrigeration system is heavily dependent upon proper expansion valve adjustment. Therefore, the importance of maintaining the proper superheat cannot be over emphasized. Accurate measurements of superheat will provide the following information.

- a. How well the expansion valve is controlling the refrigerant flow.

System Start-Up

- b. The efficiency of the evaporator.
- c. The amount of protection the compressor is receiving against flooding or overheating.

The recommended range for superheat is 10 to 16 degrees at the evaporator. Systems operating with less than 10 degrees of superheat:

- a. Could cause serious compressor damage due to refrigerant floodback.
- b. Removes working surface from the evaporator normally used for heat transfer.

Systems operating with superheat in excess of 16 degrees:

- a. Could cause excessive compressor cycling on internal winding thermostat which leads to compressor motor failure.
- b. Lowers the efficiency of the evaporator by reducing the heat transfer capability.

Measuring Superheat

- a. Measure the suction pressure at the suction line gauge access port located near the compressor.

- b. Using a Refrigerant / Temperature chart, convert the pressure reading to a corresponding saturated vapor temperature.
- c. Measured the suction line temperature as close to the expansion valve bulb, as possible.
- d. Subtract the saturated vapor temperature obtained in step b from the actual suction line temperature obtained in step c. The difference between the two temperatures is known as "superheat".

Note: When adjusting superheat, recheck the system subcooling before shutting the system "Off".

- 7. Once the checks and adjustments for the operating circuit has been completed, check and record the:

- ambient temperature;
- compressor oil level (each circuit);
- compressor suction and discharge pressures (each circuit);
- superheat and subcooling (each circuit);

Record this data on an "operator's maintenance log" shown in Table 11.

Figure 16
Typical Compressor Locations

CGAF 20 Ton Unit

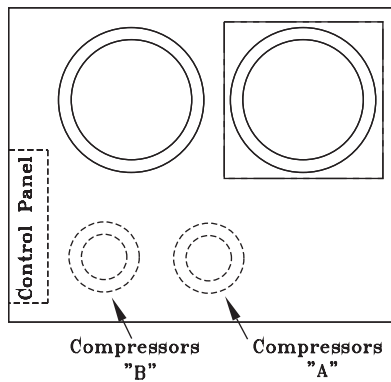

CGAF 25 Ton Unit

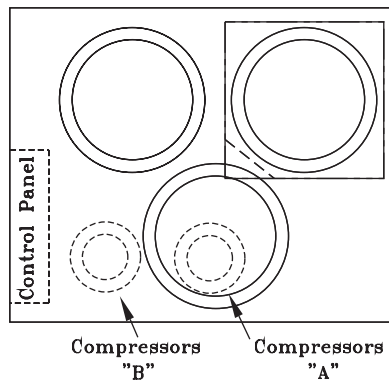

CGAF 30 Ton Unit

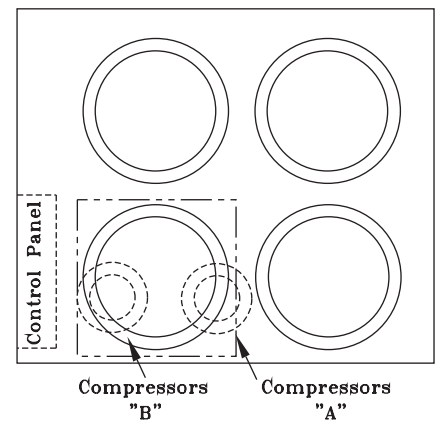

CGAF 40 Ton Unit

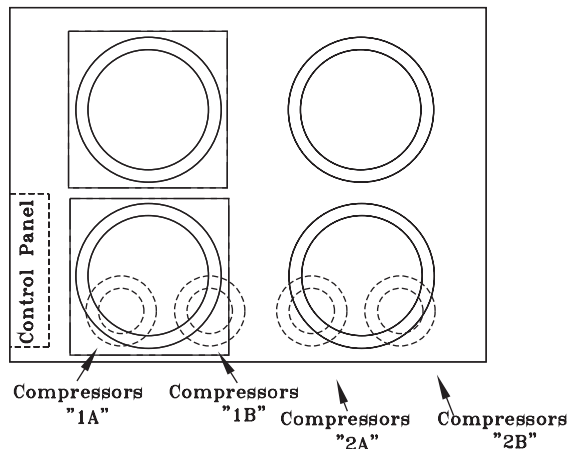

CGAF 50 & 60 Ton Unit

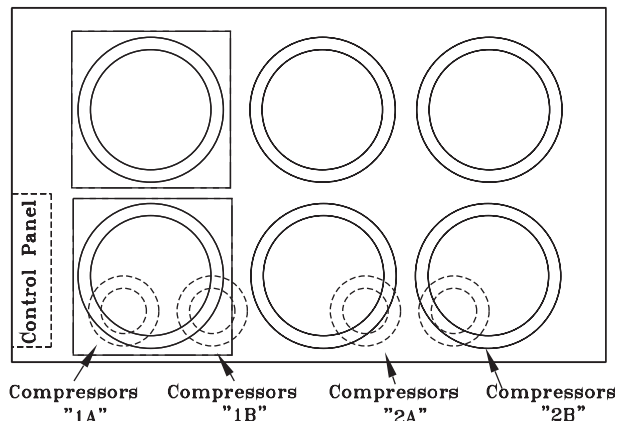

System Start-Up

- Press the STOP key at the Human Interface Module in the unit control panel to stop the system operation.
- Repeat steps 1 through 8 for the number 2 refrigeration circuit.
- After shutting the system off, check the compressor's oil's appearance. Discoloration of the oil indicates that an abnormal condition has occurred. If the oil is dark and smells burnt, it has overheated because of: compressor is operating at extremely high condensing temperatures; high superheat; a compressor mechanical failure; or, occurrence of a motor burnout.

If the oil is black and contains metal flakes, a mechanical failure has occurred. This symptom is often accompanied by a high compressor amperage draw.

If a motor burnout is suspected, use an acid test kit to check the condition of the oil. Test results will indicate an acid level exceeding 0.05 mg KOH/g if a burnout occurred.

Compressor Oil

The scroll compressor uses **Trane OIL-42 without substitution**. The appropriate oil charge for a 9 and 10 Ton scroll compressor is 8.5 pints. For a 14 and 15 Ton scroll compressor, use 13.8 pints.

Table 10
Recommended Refrigerant Capacities

Unit Size	Refrigerant Charge*
C20	40.5
C25	54.0
C30	72.0
C40	38.0
C50	47.0
C60	67.0

*The listed refrigerant charge is for pounds per circuit.

Figure 17
Typical Compressor Terminal Block

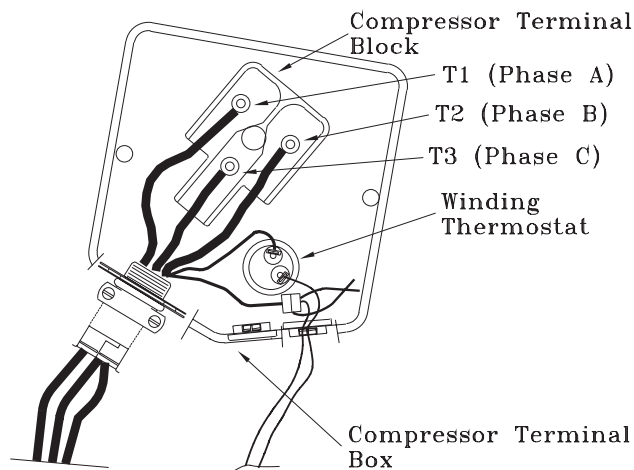

Compressor Crankcase Heaters

Each compressor is equipped with a crankcase heater and is controlled by a 600 volt auxiliary switch on the compressor contactor. The proper operation of the crankcase heater is important to maintain an elevated compressor oil temperature during the "Off" cycle to reduce oil foaming during compressor starts.

When the compressor starts, the sudden reduction in crankcase pressure causes the liquid refrigerant to boil rapidly causing the oil to foam. This condition could damage compressor bearings due to reduced lubrication and could cause compressor mechanical failures.

When power has been "Off" for an extended period, allow the crankcase heater to operate a minimum of 8 hours before starting the unit.

Low Ambient Damper Adjustment (Factory or Field Installed)

When a unit is ordered with the low ambient option (i.e., a "W" in the miscellaneous digit of the model number), a damper is factory installed over the lead condenser fan for each refrigeration circuit. Refer to the appropriate unit illustrated in Figure 15 for the damper locations.

For field installation, mount the dampers over the condenser fans at the locations shown in Figure 15 and connect the actuator, controller, and sensor for each circuit. (Refer to the Installation Instructions provided with each low ambient damper kit.)

The UCM has a factory default setpoint of 90°F. This setpoint can be adjusted using the Human Interface programming procedures.

Inspect the damper blades for proper alignment and operation. Dampers should be in the closed position during the "Off" cycle. If adjustment is required;

- At the Human Interface, program the actuator for 0% on circuit #1 and/or circuit #2. (The output signal will go to 0.0 VDC.)
- Loosen the damper shaft "Locking" set screws on the actuator.
- Firmly hold the damper blades in the closed position.
- Tighten the "Locking" set screws.

To check damper operation, program the actuator for 100% on circuit #1 and/or circuit #2. (The output signal will go to 10 VDC and the damper will drive to the full open position.)

Final System Setup

After completing all of the checkout and start-up procedures outlined in the previous sections (i.e., operating the unit in each of its Modes through all available stages of cooling), perform these final checks before leaving the unit:

- [] Close the disconnect switch or circuit protector switch that provides the supply power to the unit's terminal block 1TB1 or the unit mounted disconnect switch 1S14.

System Start-Up

⚠ WARNING
Hazardous Voltage!

Disconnect all electric power, including remote disconnects before servicing. Follow proper lockout/tagout procedures to ensure the power can not be inadvertently energized. Failure to disconnect power before servicing could result in death or serious injury.

HIGH VOLTAGE IS PRESENT AT TERMINAL BLOCK 1TB1 OR UNIT DISCONNECT SWITCH 1S14.

- [] Turn the solution pump control circuit disconnect switch to the "Off" position.
- [] At the Human Interface Module, press the "SETUP" key. The LCD screen will display various preset "parameters of operation" based on the unit type, size, and the installed options. Compare the factory preset information to the specified application requirements. If adjustments are required, follow the step-by-step instructions provided in the appropriate CG-SVP manual

- [] Program the Night Setback (NSB) panel (if applicable) for proper unoccupied operation. Refer to the programming instructions for the specific panel.
- [] Verify that the Remote panel "System" selection switch, "Fan" selection switch, and "Zone Temperature" settings for comfort systems are correct.
- [] Inspect the unit for misplaced tools, hardware, and debris.
- [] Turn the solution pump control circuit disconnect switch to the "On" position.
- [] Press the "AUTO" key at the Human Interface Module to begin system operation. The system will start automatically once a request for solution cooling has been initiated.

Note: Pump operation is dependent upon proper solution flow proving switch operation. Please see section titled "Loss-Of-Flow Protection" under General Information for details.

- [] Verify that all exterior panels including the control panel doors and condenser grilles are secured in place.

Table 11
Sample Operator's Maintenance Log

Date	Current Ambient Temp. (F)	Refrigerant Circuit #1						Refrigerant Circuit #2					
		Compr. Oil Level	Suct. Press. (Psig)	Disch. Press. (Psig)	Liquid Press. (Psig)	Super-heat (F)	Sub-cool. (F)	Compr. Oil Level	Suct. Press. (Psig)	Disch. Press. (Psig)	Liquid Press. (Psig)	Super-heat (F)	Sub-cool. (F)
		- ok - low						- ok - low					
		- ok - low						- ok - low					
		- ok - low						- ok - low					
		- ok - low						- ok - low					
		- ok - low						- ok - low					
		- ok - low						- ok - low					
		- ok - low						- ok - low					
		- ok - low						- ok - low					
		- ok - low						- ok - low					

Note: Check and record the data requested above each month during the cooling season with the unit running.

Service & Maintenance

Compressor Operational Sounds

Because of the scroll compressor design, it emits a higher frequency tone (sound) than a reciprocating compressor. It is designed to accommodate liquids, both oil and refrigerant, without causing compressor damage. The following discussion describes some of the operational sounds that differentiate it from those typically associated with a reciprocating compressor. These sounds do not affect the operation or reliability of the compressor.

At Shutdown:

When a scroll compressor shuts down, the gas within the scroll expands and causes momentary reverse rotation until the discharge check valve closes. This results in a “flutter” type sound.

At Low Ambient Start-Up

When the compressor starts up under low ambient conditions, the initial flow rate of the compressor is low due to the low condensing pressure. This causes a low differential across the thermal expansion valve that limits its capacity. Under these conditions, it is not unusual to hear the compressor rattle until the suction pressure climbs and the flow rate increases.

Scroll Compressor Replacement

Table 12 lists the specific compressor electrical data and the circuit breaker operating ranges.

The compressor manifold system was purposely designed to provide proper oil return to each compressors. The refrigerant manifolded system must not be modified in any way.

Note: Altering the manifold piping may cause oil return problems and compressor failure.

Should a compressor replacement become necessary and a suction line filter drier is to be installed, install it a minimum of 18 inches upstream of the oil separator tee. Refer to the illustration in Figure 18.

Anytime a compressor is replaced, the oil for each compressor within the manifolded set must be replaced.

The scroll compressor uses **Trane OIL-42 without substitution**. The appropriate oil charge for a 9 and 10 Ton scroll compressor is 8.5 pints. For a 14 and 15 Ton scroll compressor, use 13.8 pints.

Note: Do Not release refrigerant to the atmosphere! If adding or removing refrigerant is required, the service technician must comply with all Federal, State and local laws. Refer to general service bulletin MSCU-SB-1 (latest edition).

Note: Refrigerant oil is detrimental to some roofing materials. Care must be taken to protect the roof from oil leaks or spills.

Figure 18
Suction Line Filter/Drier Installation

30 Ton Compressor Assembly

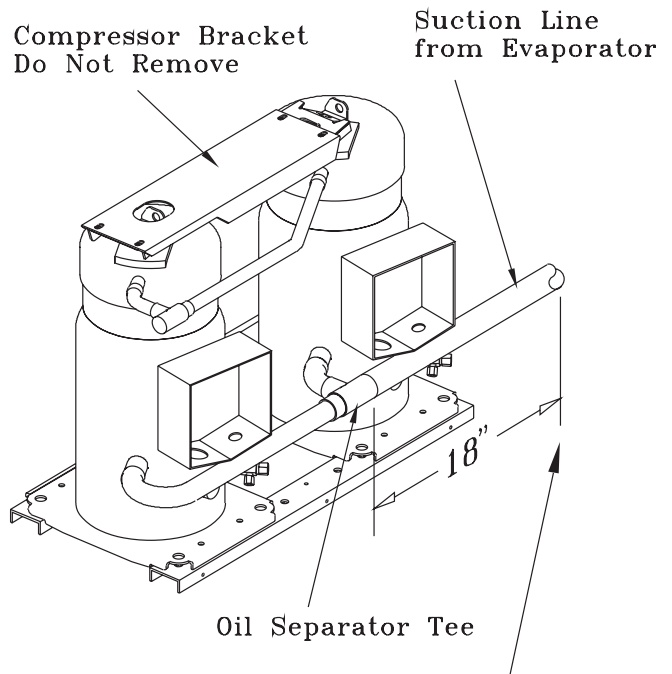

Minimum 18" straight unobstructed piping between the Suction Filter/Drier and the Oil Separator Tee.

Service & Maintenance

Table 12
Compressor Circuit Breaker Data

Unit Size	Number of Compressors	Compressor Capacities	Rated Voltage	Compressor RLA	Compressor LRA	Must Hold (AMPS)	Must Trip (AMPS)
C20	2	9	200	39.4	269	43.2	49.7
			230	39.4	251	43.2	49.7
			380/415	17.2	110	18.9	21.7
			460	17.2	117	18.9	21.7
			575	13.2	94	15.1	17.4
			200	39.3, 56.9	269, 409	47.8, 67.6	55.0, 77.7
C25	1, 1	10, 15	230	39.3, 56.9	251, 376	47.8, 67.6	55.0, 77.7
			380/415	17.3, 25.2	110, 174	20.8, 29.5	23.9, 33.9
			460	17.1, 25.4	117, 178	20.8, 29.5	23.9, 33.9
			575	13.8, 20.2	94, 143	16.8, 23.6	19.3, 27.2
C30	2	15	200	56.9	409	67.6	77.7
			230	56.9	376	67.6	77.7
			380/415	25.2	174	29.5	33.9
			460	25.1	178	29.5	33.9
			575	19.9	143	23.6	27.2
C40	4	9	200	39.4	269	43.2	49.7
			230	39.4	251	43.2	49.7
			380/415	17.2	110	18.9	21.7
			460	17.2	117	18.9	21.7
			575	13.2	94	15.1	17.4
C50	2, 2	9, 14	200	35.5, 55.5	269, 409	43.2, 67.6	49.7, 77.7
			230	35.5, 55.5	251, 376	43.2, 67.6	49.7, 77.7
			380/415	15.5, 24.2	110, 174	18.9, 29.5	21.7, 33.9
			460	15.5, 24.2	117, 178	18.9, 29.5	21.7, 33.9
			575	12.4, 19.4	94, 143	15.1, 23.6	17.4, 27.2
C60	4	15	200	56.9	409	69.3	79.7
			230	56.9	376	69.3	79.7
			380/415	25.2	174	30.7	35.3
			460	25.4	178	30.7	35.3
			575	20.2	143	24.6	28.3

Fuse Replacement Data

Table 13 lists the replacement fuses for the control circuit, compressors, and condenser fans.

Table 13
Fuse Replacement Data

FUSE REPLACEMENT TABLE							
CONDENSER FAN FUSE 1F1 THRU 1F6 CLASS RK5	UNIT VOLTAGE	200	230	380	415	460	575
	TIME DELAY	25A	25A	15A	15A	15A	15A
CONTROL POWER FUSE	1F7			CLASS K5		6.25 AMP	
COMPRESSOR PROTECTION FUSE	1F44	1F45		TYPE MTH		6 AMP	
TRANSFORMER PROTECTION FUSE	1F72 THRU 1F74			TYPE FLQ		15 AMP	

2307-3952

Service & Maintenance

Monthly Maintenance

Before completing the following checks, turn all system control circuit switches to the “Off” position.

“Open” the main power disconnect switches for the Condensing Unit and all system support equipment. “lock” the disconnect switches in the “Off” position before removing any access panels.



WARNING **Hazardous Voltage!**

Disconnect all electric power, including remote disconnects before servicing. Follow proper lockout/tagout procedures to ensure the power can not be inadvertently energized. Failure to disconnect power before servicing could result in death or serious injury.

Air Handling Equipment (Comfort Applications)

- [] Inspect the return air filters. Clean or replace them if necessary.
- [] Check the drain pan and condensate piping to ensure that there are no blockages.
- [] Inspect the evaporator (DX and/or Hydronic) coils for dirt. If the coils appear dirty, clean them according to the instructions described in the “Coil Cleaning” section.
- [] Inspect the economizer damper hinges and pins (if applicable) to ensure that all moving parts are securely mounted. Clean the blades as necessary.
- [] Verify that all damper linkages move freely (if applicable); lubricate with white grease, if necessary.
- [] Check Supply Fan motor bearings; repair or replace the motor as necessary.
- [] Check the fan shaft bearings for wear. Replace the bearings as necessary.
- [] Lubricate the supply fan bearings. Refer to the equipment manufacturer for their recommended greases.

Note: Over lubrication can be just as harmful as not enough grease.

Use a hand grease gun to lubricate these bearings; add grease until a light bead appears all around the seal. Do not over lubricate!

After greasing the bearings, check the setscrews to ensure that the shaft is held securely to the bearings and Fan wheels. Make sure that all bearing supports are tight.

- [] Check the supply fan belt(s). If the belts are frayed or worn, replace them.
- [] Verify that all wire terminal connections are tight.
- [] Generally inspect the unit for unusual conditions (e.g., loose access panels, leaking piping connections, etc.)
- [] Make sure that all retaining screws are reinstalled in the unit access panels once these checks are complete.

Condensing Unit

- [] Manually rotate the condenser fans to ensure free movement and check motor bearings for wear. Verify that all of the fan mounting hardware is tight.
- [] Verify that all wire terminal connections are tight.
- [] Inspect the condenser coils for dirt and foreign debris. If the coils appear dirty, clean them according to the instructions described in the “Coil Cleaning” section.
- [] Straighten any bent coil fins with a fin comb. Refer to Table 14 to determine the appropriate fin comb size.
- [] Inspect the compressor and condenser fan motor contactors. If the contacts appear severely burned or pitted, replace the contactor. Do not clean the contacts.
- [] Check the compressor oil level. (Compressors “Off”)

Table 14
Condenser Coil Data

Unit Size	Number of Coils	Coil Fin Configuration	Tube Diameter	Coil Rows	Fins per Foot	Coil Size (inches)	Subcooler Size (inches)	Tube Type
C20	1	Slit Fin	0.375"	3	144	61 X 71	10 X 71	smooth
C25	2	Slit Fin	0.375"	3	144	45 X 71 35 X 71	14 X 71	smooth
C30	2	Slit Fin	0.375"	3	144	56 X 70	9 X 70	smooth
C40	2	Slit Fin	0.375"	3	144	56 X 70	9 X 70	smooth
C50	2	Slit Fin	0.375"	3	144	57 X 96	9 X 96	smooth
C60	2	Slit Fin	0.375"	4	144	57 X 96	9 X 96	smooth

Service & Maintenance

Coil Cleaning

Regular coil maintenance, including annual cleaning, enhances the unit's operating efficiency by minimizing:

compressor head pressure and amperage draw;
evaporator water carryover;
fan brake horsepower, due to increase static pressure losses;
airflow reduction.

At least once each year, or more often if the unit is located in a "dirty" environment, clean the evaporator and condenser coils using the instructions outlined below. Be sure to follow these instructions as closely as possible to avoid damaging the coils.

To clean refrigerant coils, use a soft brush and a sprayer (either a garden pump-up type or a high-pressure sprayer). A high-quality detergent is also required; suggested brands include "SPREX A.C.", "OAKITE 161", "OAKITE 166" and "COILOX". If the detergent selected is strongly alkaline (ph value exceeds 8.5), add an inhibitor.



WARNING **Hazardous Chemicals!**

Coil cleaning agents can be either acidic or highly alkaline. Handle chemical carefully. Proper handling should include goggles or face shield, chemical resistant gloves, boots, apron or suit as required. For personal safety refer to the cleaning agent manufacturer's Materials Safety Data Sheet and follow all recommended safe handling practices. Failure to follow all safety instructions could result in death or serious injury.

1. Remove enough panels from the unit to gain access to the coil.
2. Protect all electrical devices such as motors and controllers from any over spray.
3. Straighten any bent coil fins with a fin comb.
4. Mix the detergent with water according to the manufacturer's instructions. If desired, heat the solution to 150°F maximum to improve its cleansing capability.



CAUTION **Compressor Damage!** **Contains Refrigerant!**

Do not allow liquid refrigerant to enter the suction line. Excessive liquid accumulation in the liquid lines may result in compressor damage.

Do not heat the detergent-and-water solution above 150° F. Hot liquids sprayed on the exterior of the coil will raise the coil's internal pressure and may cause it to burst.

Note: Refrigerant oil is detrimental to some roofing materials. Care must be taken to protect the roof from oil leaks or spills.

5. Pour the cleaning solution into the sprayer. If a high-pressure sprayer is used:
 - a. do not allow sprayer pressure to exceed 600 psi.
 - b. the minimum nozzle spray angle is 15 degrees.
 - c. maintain a minimum clearance of 6" between the sprayer nozzle and the coil.
 - d. spray the solution perpendicular (at 90 degrees) to the coil face.
6. Spray the leaving-airflow side of the coil first; then spray the opposite side of the coil. Allow the cleaning solution to stand on the coil for five minutes.
7. Rinse both sides of the coil with cool, clean water.
8. Inspect both sides of the coil; if it still appears to be dirty, repeat Steps 6 and 7. Do not spray cleaner in heavy winds to prevent overspray from possible contacting other building components and other adjacent objects such as automobiles etc. Flush coil cleaners from all surfaces thoroughly to prevent possible damage.
9. Reinstall all of the components and panels removed in Step 1 and any protective covers installed in step 2.
10. Restore the unit to its operational status and check system operation.

System operation

- [] Close the main power disconnect switch for the unit and all system support equipment. Turn all system control circuit switches to the "On" position.



WARNING **Hazardous Voltage!** **Rotating Parts!**

Disconnect all electric power, including remote disconnects before servicing. Follow proper lockout/tagout procedures to ensure the power can not be inadvertently energized. Failure to disconnect power before servicing could result in death or serious injury.

- [] With the unit running, check and record the:

ambient temperature;
compressor oil level (each circuit);
compressor suction and discharge pressures (each circuit);
superheat and Subcooling (each circuit);

Record this data on an "operator's maintenance log" similar to the one illustrated in the "Final Setup" section of this manual. If the operating pressures indicate a refrigerant shortage, measure the system Superheat and system Subcooling. For guidelines, refer to the "system Start-Up" section.

Note: Do Not release refrigerant to the atmosphere! If adding or removing refrigerant is required, the service technician must comply with all federal, state and local laws. Refer to general service bulletin MSCU-SB-1 (latest edition).

Service & Maintenance

Annual Maintenance

- [] Perform all weekly and monthly maintenance procedures.
- [] Have a qualified service technician check the setting and function of each control and inspect the condition of and replace compressor and control contactors if needed.
- [] If chiller is not piped to drain facilities, make sure drain is clear to carry away system water.
- [] Drain water from evaporator and associated piping systems. Inspect all piping components for leakage, damage, etc. Clean out any in-line water strainers.
- [] Clean and repaint any corroded surface.
- [] Check low ambient dampers for proper operation.
- [] Clean condenser coils. Refer to "Coil Cleaning".



WARNING **Hazardous Voltage!**

Disconnect all electric power, including remote disconnects before servicing. Follow proper lockout/tagout procedures to ensure the power can not be inadvertently energized. Failure to disconnect power before servicing could result in death or serious injury.

- [] Inspect the expansion valve sensing bulbs for cleanliness. Clean if required. Sensing bulbs must make good contact with suction lines and be properly insulated.
- [] Clean condenser fans. Check fan assemblies for proper orifice clearance and for motor shaft mis-alignment, abnormal end-play or vibration and noise.



WARNING **Rotating Components!**

During installation, testing, servicing and troubleshooting of this product it may be necessary to measure the speed of rotating components. Have a qualified or licensed service individual who has been properly trained in handling exposed rotating components, perform these tasks. Failure to follow all safety precautions when exposed to rotating components could result in death or serious injury.

Final Process

For future reference, you may find it helpful to record the unit data requested below in the blanks provided.

(1) Complete Unit Model Number:

(2) Unit Serial Number:

(3) Unit "DL" Number ("design special" units only):

(4) Wiring Diagram Numbers (from unit control panel):

— schematic(s)

— connection(s)

Unit Address (TCI)

Network ID (LCI)

WARRANTY AND LIABILITY CLAUSE

COMMERCIAL EQUIPMENT RATED 20 TONS AND LARGER AND RELATED ACCESSORIES

PRODUCTS COVERED - This warranty* is extended by American Standard Inc. and applies only to commercial equipment rated 20 Tons and larger and related accessories.

The Company warrants for a period of 12 months from initial start-up or 18 months from date of shipment, whichever is less, that the Company products covered by this order (1) are free from defects in material and workmanship and (2) have the capacities and ratings set forth in the Company's catalogs and bulletins, provided that no warranty is made against corrosion, erosion or deterioration. The Company's obligations and liabilities under this warranty are limited to furnishing f.o.b. factory or warehouse at Company designated shipping point, freight allowed to Buyer's city (or port of export for shipment outside the conterminous United States) replacement equipment (or at the option of the Company parts therefore) for all Company products not conforming to this warranty and which have been returned to the manufacturer. The Company shall not be obligated to pay for the cost of lost refrigerant. No liability whatever shall attach to the Company until said products have been paid for and then said liability shall be limited to the purchase price of the equipment shown to be defective.

The Company makes certain further warranty protection available on an optional extra-cost basis. Any further warranty must be in writing, signed by an officer of the Company.

The warranty and liability set forth herein are in lieu of all other warranties and liabilities, whether in contract or in negligence, express or implied, in law or in fact, including implied warranties of merchantability and fitness for particular use. In no event shall the Company be liable for any incidental or consequential damages.

THE WARRANTY AND LIABILITY SET FORTH HEREIN ARE IN LIEU OF ALL OTHER WARRANTIES AND LIABILITIES, WHETHER IN CONTRACT OR IN NEGLIGENCE, EXPRESS OR IMPLIED, IN LAW OR IN FACT, INCLUDING IMPLIED WARRANTIES OF MERCHANTABILITY AND FITNESS FOR PARTICULAR USE, IN NO EVENT SHALL WARRANTOR BE LIABLE FOR ANY INCIDENTAL OR CONSEQUENTIAL DAMAGES.

Manager - Product Service
American Standard Inc.
Clarksville, Tn 37040-1008

PW-215-2688

*Optional Extended Warranties are available for compressors and heat exchangers of Combination Gas-Electric Air Conditioning Units.

Index

A

AC Conductors...32; *See* Table 5
Air Handling Equipment...55
Air Vents...24
Align the mounting holes...19

B

Balancing Valves...24

C

C20 Ton Unit Dimensional Data...12; *See* Figure 2
C25 Ton Unit Dimensional Data...13; *See* Figure 2
C30 Ton Unit Dimensional Data...14; *See* Figure 2
C40 Ton Unit Dimensional Data...15; *See* Figure 2
C50 Ton Unit Dimensional Data...16; *See* Figure 2
C60 Ton Unit Dimensional Data...17; *See* Figure 2
Cautions...4
chiller drain...24
Chiller Flow Switch...24
Circulating Pump Interlock...32
clearance adjustments...19
Clearance Requirements Around Water Pipe...25; *See* Figure 7C
“COILOX”...56
Compressor Circuit Breaker Data...54; *See* Table 12
Compressor Circuit Breakers...7
Compressor Crankcase Heaters ...51
compressor discharge service valve...38
Compressor Inhibit / KW Limit...33
Compressor Lockout...7
Compressor Module...5
Compressor Motor Winding Thermostats...7
Compressor Nameplate...4
Compressor Oil...51
Compressor Shipping Hardware...22; *See* Figure 6
concealed damage...10
Condenser Coil Data...55; *See* Table 14
Condenser Fan Control...43
Condenser Fan Locations...48; *See* Figure 15
condensing temperature rises above the “lower limi...6
Condensing Unit...55
Connection Diagram Notes...37
Connection Wire Range...29; *See* Table 3
Control for Comfort Applications...40
Control for Ice Building...40
Control for Process Applications...41
Current Sensing Module...5

D

DC Conductors...33; *See* Table 6
discharge pressure approaches 405 ± 7 psig...6
discharge pressure decreases to approximately 300...6
Drain Plug...24

E

Edge Protector...25; *See* Figure 7B
“efficiency check point” setting...6
Electrical Service Sizing Data...31
Emergency Stop...8
Evaporator Nameplate...4
Evaporator Data...44; *See* Table 9
Evaporator water inlet and outlet types...23
Evaporator Water-Pressure Drop...45; *See* Figure 13
External Auto/Stop...8, 32

F

factory mounted disconnect switch...28
Field Control Connections Diagram; *See* Figure 12A
Field Installed Power Wiring...29; *See* Figure 11
Flow Control Interlock...32
Flow Switch Interlock...8
flushing water piping...26
Freeze Protection...40
Freeze Protection Diagnostic...40
Fuse Replacement Data...54; *See* Table 13

G

GBAS 0 - 10 Volt Connections Diagram;
See Figure 12C
GBAS 0 - 5 Volt Connections Diagram;
See Figure 12B
General Unit Requirement...38
Generic Building Automation System...5

H

Head Pressure Control...6
Heat Tape Installation...27; *See* Figure 10: Table 2A:
Table 2B
High Pressure Controls...6
Hot Gas Bypass...43
Hot Operation...7
Hot Start...7
Human Interface Module...5

I

Ice Building Control...33
ICS™ Communication Link...33
Installation Clearances...11
Interprocessor Communications Board...5

L

“Layout” and “Shipwith”...9
Lead-Lag...6, 43
Leaving Solution Reset...41
Level the unit...19
LonTalk Communication Interface Module...5
Loss of Flow (Refrigerant)...6

Loss-of-Flow (Solution)...7
Low Ambient Control...6
Low Ambient Dampers...44
low ambient option...51
Low Ambient Pump Control...8
Low Ambient Start...7

M

maximum allowable voltage imbalance...38
Maximum Communications Wiring Length...33; *See*
Table 7
maximum isolator deflection...19
microelectronics control system...5
motor winding temperature decreases to approxi-
mate...7
motor windings exceeds approximately 221 F...7

N

Neoprene Isolator Selection...20; *See* Figure 4
Neoprene Isolators...19

O

“OAKITE 161”...56
“OAKITE 166”...56
Operator’s Maintenance Log...52; *See* Table 11
Optional Flow Switch...26
Optional Flow Switch Illustration; *See* Figure 9

P

pipe strainer...24
Pipe Unions...24
pressure gauge...24

R

Refrigerant Capacities...51; *See* Table 10
Refrigerant Charging...49
Reset Schedule based on Entering Solution
Temperat...43; *See* Table 8C
Reset Schedule based on Outside Air
Temperature...42; *See* Table 8B
Reset Schedule based on Zone
Temperature...42; *See* Table 8A
Rigging and Center-of-Gravity...18, 19; *See* Figure 3

S

Saturated Condenser Temperature Sensors...6
saturated condensing temperature falls...6
scroll compressor design...53

Secure the isolator...19
shell-and-tube type evaporator...5
“Shipwith” items...5
“Shipwith” Locations...5
Short Cycle Protection...7
shutoff valves...24
Solution Freezing Points...46; *See* Figure 14
Solution Pump Interlock...7
“SPREX A.C.”...56
Spring Isolator Selection...21; *See* Figure 5
Spring Isolators...19
Status/Alarm Output...7
Strainer...24
Suction Line Filter/Drier; *See* Figure 18
Suction Line Filter/Drier Installation...53
suction pressure approaches 7 ± 4 psig...6
suction pressure exceeds 22 ± 4 psig...6
Superheat...49
Superheat & Subcooling Module...5

T

“temporary low limit suppression” setting...6
Thermometers...24
Trane Communications Interface Module...5
Trane OIL-42...51
Typical Compressor Locations; *See* Figure 16
Typical Compressor Terminal Block...51;
See Figure 17
Typical Piping recommendations...26
Typical Water Piping Recommendations;
See Figure 8

U

Unit Nameplate...4
Unit Weights & Point Loading...18; *See* Table 1

V

vibration eliminators...24
Voltage Monitoring...7

W

Warnings...4
Water Access Holes...25; *See* Figure 7A
Water Pressure Gauges...24
Water Shutoff Valves...24

