



Installation Operation Maintenance

Series R[®] Rotary Liquid Chillers Water-Cooled and Condenserless

Packaged Water-Cooled Chiller,
RTWA 70-125

Water-Cooled Compressor
Chiller RTUA 70-125

Air-Cooled Condenser
RTCA 70-125

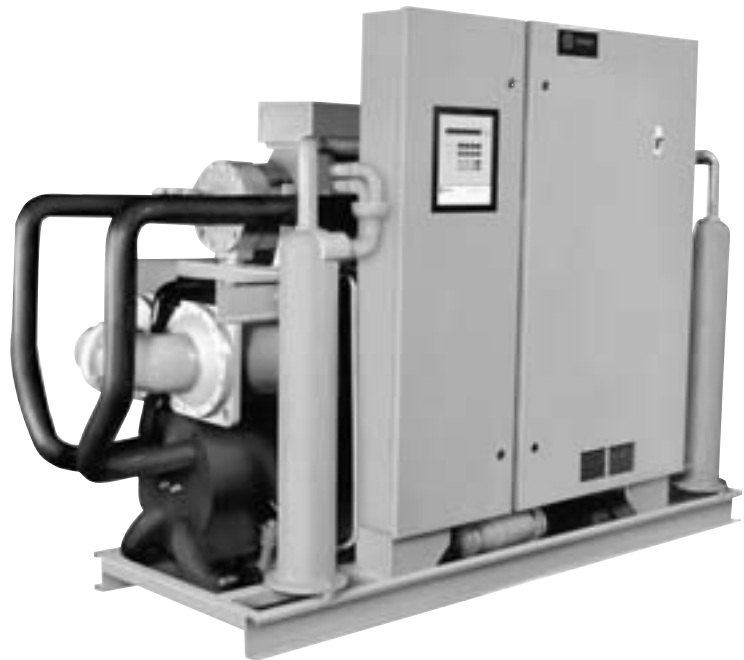

Models

RTWA-70	RTUA-70	RTCA-70
RTWA-80	RTUA-80	RTCA-80
RTWA-90	RTUA-90	RTCA-90
RTWA-100	RTUA-100	RTCA-100
RTWA-110	RTUA-110	RTCA-110
RTWA-125	RTUA-125	RTCA-125

October 2005

RLC-SVX07A-EN



NOTICE: Warnings and Cautions appear at appropriate sections throughout this literature. Read these carefully.

⚠ WARNING: Indicates a potentially hazardous situation which, if not avoided, could result in death or serious injury.

⚠ CAUTION: Indicates a potentially hazardous situation which, if not avoided, may result in minor or moderate injury. It may also be used to alert against unsafe practices.

CAUTION: Indicates a situation that may result in equipment or property-damage only accidents.

Important Environmental Concerns!

Scientific research has shown that certain man-made chemicals can affect the earth's naturally occurring stratospheric ozone layer when released to the atmosphere. In particular, several of the identified chemicals that may affect the ozone layer are refrigerants that contain Chlorine, Fluorine and Carbon (CFCs) and those containing Hydrogen, Chlorine, Fluorine and Carbon (HCFCs). Not all refrigerants containing these compounds have the same potential impact to the environment. Trane advocates the responsible handling of all refrigerants—including industry replacements for CFCs such as and HCFCs and HFCs.

Responsible Refrigerant Practices!

Trane believes that responsible refrigerant practices are important to the environment, our customers, and the air conditioning industry. All technicians who handle refrigerants must be certified. The Federal Clean Air Act (Section 608) sets forth the requirements for handling, reclaiming, recovering and recycling of certain refrigerants and the equipment that is used in these service procedures. In addition, some states or municipalities may have additional requirements that must also be adhered to for responsible management of refrigerants. Know the applicable laws and follow them.

⚠ WARNING Contains Refrigerant!

System contains oil and refrigerant under high pressure. Recover refrigerant to relieve pressure before opening the system. See unit nameplate for refrigerant type. Do not use non-approved refrigerants, refrigerant substitutes, or refrigerant additives.

Failure to follow proper procedures or the use of non-approved refrigerants, refrigerant substitutes, or refrigerant additives could result in death or serious injury or equipment damage.



Contents

General Information	5
Unit Identification	5
Unit Inspection	5
Inspection Checklist	5
Loose Parts Inventory	5
Unit Description	5
Installation Responsibilities	9
Nameplates	10
Unit Nameplate	10
Model Number Coding System	11
Storage	14
Installation - Mechanical	15
Pre-Installation	15
Location Requirements	15
Rigging	15
Lifting Procedure	16
Unit Isolation and Leveling	27
Water Piping	31
Evaporator Water Piping (for RTWA and RTUA Units Only)	31
Condenser Water Piping (for RTWA Units Only)	38
Water Regulations Valve (for RTWA Units Only)	39
Water Treatment	41
Water Pressure Gauges	41
Water Pressure Relief Valves	41
Field-Installed Water Temperature Sensors	41
Water Sensor Installation Procedure	41
Refrigerant Relief Valve Venting	42
Initial Leak Test	44
Installation - Remote Condenser	45
Remote Air-Cooled Condenser Interconnecting Refrigerant Piping	45
Installation - Electrical	58
Installer-Supplied Components	62
Power Supply Wiring	62
Interconnecting Wiring	62
Low Voltage Wiring	67
Optional Bidirectional Communications Link (BCL)	75
Remote Clear Language Display Installation Procedure	77
Installation Checklist	81
Operating Principles	83
Refrigeration (Cooling) Cycle	85
Oil System Operation (RTWA and RTUA Only)	87
Controls Interface	91
Clear Language Display Keypad Overview	91
Diagnostics	112
Operational Features	113
DIP Switch Settings	120
Pre-Start Checkout	122
Unit Voltage Power Supply	123



Contents

Unit Voltage Imbalance	124
Unit Voltage Phasing	124
Water System Flow Rates	126
Water System Pressure Drop	126
Start-Up Procedures	127
System Superheat	128
System Subcooling	128
Unit Shutdown Procedures	131
Temporary Shutdown and Restart	131
Extended Shutdown Procedure	131
System Restart after Extended Shutdown	131
Periodic Maintenance	133
Weekly Maintenance	133
Monthly Maintenance	133
Annual Maintenance	133
Maintenance	137
Cleaning the Evaporator (RTWA and RTUA)	137
Cleaning the Condenser	137
Water Treatment	139
Oil Separator Level Check	139
Refrigerant Charging	143
Adding Refrigerant	143
Low Side Repairs	144
High Side Repair	144
Diagnostics	146
Unit Wiring	155
Unit Wiring	155



General Information

Unit Identification

When the unit arrives, compare all nameplate data with ordering and shipping information.

Unit Inspection

When the unit is delivered, verify that it is the correct unit and that it is properly equipped. Compare the information which appears on the unit nameplate with the ordering and submittal information. Refer to "Nameplates".

Inspect all exterior components for visible damage. Report any apparent damage or material shortage to the carrier and make a "unit damage" notation on the carrier's delivery receipt. Specify the extent and type of damage found and notify the appropriate Trane Sales Office.

Do not proceed with installation of a damaged unit without sales office approval.

Inspection Checklist

To protect against loss due to damage incurred in transit, complete the following checklist upon receipt of the unit.

- Inspect the individual pieces of the shipment before accepting the unit. Check for obvious damage to the unit or packing material.
- Inspect the unit for concealed damage as soon as possible after delivery and before it is stored. Concealed damage must be reported within 15 days.
- If concealed damage is discovered, stop unpacking the shipment. Do not remove damaged material from the receiving location. Take photos of the damage, if possible. The owner must provide reasonable evidence that the damage did not occur after delivery.
- Notify the carrier's terminal of the damage immediately, by phone and by mail. Request an immediate, joint inspection of the damage with the carrier and the consignee.
- Notify the Trane sales representative and arrange for repair. Do not repair the unit, however, until damage is inspected by the carrier's representative.

Loose Parts Inventory

Check all the accessories and loose parts which are shipped with the unit against shipping list. Included in these items will be water vessel drain plugs, rigging and electrical diagrams, and service literature, which are placed inside the control panel and/or starter panel for shipment.

Unit Description

The RTWA 70 to 125 ton units are helical-rotary type, water-cooled, liquid chillers, designed for installation indoors. The units have 2 independent refrigerant circuits, with one compressor per circuit. The RTWA units are packaged with an evaporator and condenser.

Each RTWA unit is a completely assembled, hermetic package that is factory-piped, wired, leak-tested, dehydrated, charged and tested for proper control operations prior to shipment. The chilled water inlet and outlet openings are covered for shipment.



General Information

The RTUA 70 to 125 ton units are helical-rotary type, compressor chillers, designed to operate with the RTCA, an air-cooled condenser. The RTUA is designed for indoor installation. It has 2 independent refrigerant circuits, with one compressor per circuit. It is assembled with the discharge line leaving the oil separator capped, to enable the factory to leak-test, dehydrate and add oil charge (excluding additional oil for needed field piping). The unit ships with a nitrogen holding charge. The chilled water inlet and outlet openings are covered.

The RTCA 70 to 125 ton air-cooled condensers are dehydrated, leak tested, shipped with a nitrogen holding charge and electrically tested for proper control operation before shipment.

The RTWA/RTUA series features Trane's exclusive Adaptive Control logic with Clear Language Display. It monitors the control variables that govern the operation of the chiller unit. Adaptive Control logic can correct these variables, when necessary, to optimize operational efficiencies, avoid chiller shutdown, and keep producing chilled water. An optional remote display is available to monitor unit operation from a remote location.

Compressor unloaders are solenoid actuated and oil pressure operated. Each refrigerant circuit is provided with filter drier, sight glass, electronic expansion valve, and charging valves on the RTWA and RTUA units.

The shell-and-tube type evaporator is manufactured in accordance with ASME standards. Each evaporator is fully insulated and is equipped with water drain and vent connections.



General Information

Table 1 General Data RTWA Compressor Chiller

Size		70 Std	70 Long	80 Std	80 Long	90 Std	90 Long	100 Std	100 Long	110 Std	110 Long	125 Std	125 Long
Compressor													
Nominal Tons ¹		35/35	35/35	40/40	40/40	50/40	50/40	50/50	50/50	60/50	60/50	60/60	60/60
Quantity		2	2	2	2	2	2	2	2	2	2	2	2
Evaporator													
Water Storage	(Gallons)	39.8	39.8	37.8	37.8	35.0	35.0	32.1	32.1	51.8	51.8	47.6	47.6
	(Liters)	150.8	150.8	143.3	143.3	132.7	132.7	121.7	121.7	196.3	196.3	180.4	180.4
Min. Flow	(GPM)	84	84	96	96	108	108	120	120	132	132	150	150
	(US)	5.3	5.3	6.1	6.1	6.8	6.8	7.6	7.6	8.3	8.3	9.5	9.5
Max. Flow	(GPM)	252	252	288	288	324	324	360	360	396	396	450	450
	(US)	15.9	15.9	18.2	18.2	20.5	20.5	22.7	22.7	25.0	25.0	28.4	28.4
Condenser													
Water Storage	(Gallons)	9.0	11.8	9.9	13.0	10.9	14.7	11.8	16.4	12.6	17.5	13.4	18.5
	(Liters)	34.1	44.7	37.5	49.3	41.3	55.7	44.7	62.2	47.8	66.3	50.8	70.1
Min. Flow	(GPM)	75	90	90	105	120	145	120	145	145	170	145	170
	(US)	4.7	5.7	5.7	6.6	7.6	9.2	7.6	9.2	9.2	10.7	9.2	10.7
Max. Flow	(GPM)	275	325	325	375	325	375	440	525	440	525	525	615
	(US)	17.4	20.5	20.5	23.7	20.5	23.7	27.8	33.1	27.8	33.1	33.1	38.8
General													
Refrig. Type		HCFC-22	HCFC-22	HCFC-22	HCFC-22	HCFC-22	HCFC-22	HCFC-22	HCFC-22	HCFC-22	HCFC-22	HCFC-22	HCFC-22
Refrig. Charge	(Lb)	64/64	85/85	64/64	85/85	72/64	95/85	72/72	95/95	72/72	95/95	72/72	95/95
	(Kg)	29.1/29.1	38.6/38.6	29.1/29.1	38.6/38.6	33.4/29.1	43.6/38.6	32.7/32.7	43.1/43.1	32.7/32.7	43.1/43.1	32.7/32.7	43.1/43.1
Oil Charge ³	(Qts)	10/10	10/10	10/10	10/10	12/10	12/10	12/12	12/12	12/12	12/12	12/12	12/12
	(Lt)	11.4/11.4	11.4/11.4	43.1/43.1	11.4/11.4	11.4/11.4	11.4/11.4	11.4/11.4	11.4/11.4	11.4/11.4	11.4/11.4	11.4/11.4	11.4/11.4
Operating Wt. ²	(Lbs)	4815	4978	4847	5018	4971	5173	5108	5340	5476	5715	5546	5792
	(Kg)	2234	2258	2199	2277	2254	2346	2317	2422	2484	2592	2516	2627
Shipping Wt. ²	(Lbs)	4485	4648	4531	4702	4685	4887	4839	5071	5044	5283	5114	5360
	(Kg)	2084	2108	2055	2133	2125	2217	2195	2300	2288	2396	2320	2431
Overall (in)													
Length		99	112	99	112	103	112	102	112	132	132	132	132
Width		34	34	34	34	34	34	34	34	34	34	34	34
Height		72	72	72	72	72	72	72	72	72	72	72	72
Overall Dim. (mm)													
Length		2515	2835	2515	2835	2607	2848	2607	2848	3340	3340	3340	3340
Width		864	864	864	864	864	864	864	864	864	864	864	864
Height		1822	1822	1822	1822	1822	1822	1822	1822	1822	1822	1822	1822

1. Data containing information on two circuits shown as follows: ckt 1/ckt 2.
2. All weights include Y-Delta starters.
3. Trane Part # Oil-31.



General Information

Table 2 RTWA Refrigerant Circuit Designations and Capacities

RTWA Model	Circuit/Tons		Compressor/Tons	
70	1	35	A	35
	2	35	B	35
80	1	40	A	40
	2	40	B	40
90	1	50	A	50
	2	40	B	40
100	1	50	A	50
	2	50	B	50
110	1	60	A	60
	2	50	B	50
125	1	62.5	A	60
	2	62.5	B	60

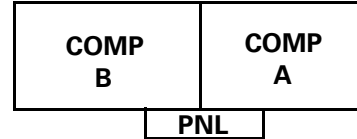

Table 3 General Data RTUA Compressor Chiller

Size		70	80	90	100	110	125
Compressor							
Nominal (Tons) ¹	(1)	35/35	40/40	50/40	50/50	60/50	60/60
Quantity		2	2	2	2	2	2
Evaporator							
Water Storage	(Gallons)	39.8	37.8	35	32.1	51.8	47.6
	(Liters)	150.8	143.3	132.7	121.7	196.3	180.4
Min. Flow	(GPM)	84.0	96.0	108.0	120.0	132.0	150.0
	(L/Sec)	5.3	6.1	6.8	7.6	8.3	9.5
Max. Flow	(GPM)	252.0	288.0	324.0	360.0	396.0	450.0
	(L/Sec)	15.9	18.2	20.5	22.7	25.0	28.4
General							
Refrig. Type		HCFC-22	HCFC-22	HCFC-22	HCFC-22	HCFC-22	HCFC-22
Oil Charge ³	(Qts)	10/10	10/10	12/10	12/12	12/12	12/12
	(Ls)	11.4/11.4	11.4/11.4	11.4/11.4	11.4/11.4	11.4/11.4	11.4/11.4
Operating Weight ²	(Lbs)	3804	3816	3895	3970	4149	4149
	(Kg)	1725	1731	1766.8	1801	1882	1882
Shipping Wt. ²	(Lbs)	3474	3500	3609	3701	3717	3717
	(Kg)	1576	1588	1637	1679	1686	1686
Overall Dim. (in)							
Length		99.0	99.0	102.6	102.6	131.5	131.5
Width		34.0	34.0	34.0	34.0	34.0	34.0
Height		71.8	71.8	71.8	71.8	71.8	71.8
Overall Dim. (mm)							
Length		2515	2515	2607	2607	3340	3340
Width		864	864	864	864	864	864
Height		1822	1822	1822	1822	1822	1822

1. Data containing information on two circuits shown as follows: ckt 1/ckt 2.

2. All weights include Y-Delta starters.

3. Trane Part # Oil-31.



General Information

Table 4 General Data RTAC Air-Cooled Condenser

Size		70	80	90	100	110	125
Condenser							
Qty. of Coils		4	4	4	4	4	4
Coil Length ¹	(In)	156/156	156/156	168/156	168/168	204/168	204/204
Coil Height	(In)	42	42	42	42	42	42
Number of Rows		2	2	2	2	2	2
Condenser Fans							
Quantity (1)		4/4	4/4	5/4	5/5	5/5	5/5
Diameter	(In)	30	30	30	30	30	30
Total Airflow	(CFM)	71750	71750	77640	83530	87505	91480
Nominal RPM		850	850	850	850	850	850
Tip Speed	(Ft. Min)	6675	6675	6675	6675	6675	6675
Motor SP	(Ea)	1.1	1.1	1.1	1.1	1.1	1.1
Min. Starting/Oper.							
Ambient ²		HCFC-22	HCFC-22	HCFC-22	HCFC-22	HCFC-22	HCFC-22
Std Unit	(Deg F)	15	15	15	15	15	15
Low Ambient	(Deg F)	-10	-10	-10	-10	-10	-10
Weights							
Operating Wt.	(Lbs)	3384	3384	3625	3686	3941	4110
	(Kg)	1535	1535	1645	1671	1788	1865
Shipping Wt.	(Lbs)	3303	3303	3531	3584	3821	3973
	(Kg)	1500	1500	1603	1627	1735	1804
Overall Dim. (in)							
Length		204	204	204	204	231	231
Width		85	85	85	85	85	85
Height		88	88	88	88	88	88
Overall Dimensions (mm)							
Length		5176	5176	5176	5176	5861	5861
Width		2240	2240	2240	2240	2240	2240
Height		2223	2223	2223	2223	2223	2223

1. Data containing information on two circuits shown as follows: ckt1/ckt2

2. Minimum start-up/operating ambient based on a 5 mph wind across the condenser.

Installation Responsibilities

Generally, the contractor must install the unit per the instructions contained in Sections 2 and 3 of this manual, including the following:

- Install unit on a flat foundation, level (within 1/4" [6.4 mm]), and strong enough to support unit loading.
- Install any optional sensors and make electrical connections at the Unit Control Panel.

NOTE: The standard leaving chilled water sensor is factory installed in the evaporator leaving water outlet.

- Where specified, provide and install valves in water piping upstream and downstream of evaporator and condenser water connections to isolate



General Information

the heat exchangers for maintenance, and to balance/trim system.

- If desired, supply and install flow switches in both the chilled water and condenser water piping; interlock each switch with proper pump starter to ensure unit can only operate if water flow is established. Chilled water flow protection is provided by the Unit Controls without the need for a chilled water flow switch. A flow switch for chilled water is strictly discretionary.
- Furnish and install pressure gauges in inlet and outlet piping of the evaporator and condenser.
- Furnish and install a drain valve to both the evaporator and condenser.
- Supply and install a vent cock to the top of the evaporator and condenser.
- Furnish and install strainers ahead of all pumps and automatic modulating valves.
- Provide and install field wiring.
- Start unit under supervision of a qualified service technician.

Nameplates

The RTWA/RTUA unit nameplates (Figure 1) are applied to the exterior surface of the Control Panel door.

A compressor nameplate is located on each compressor. The RTCA unit nameplate is applied to the side of the control panel.

Unit Nameplate

The unit nameplate provides the following information:

- Unit model and size descriptor.
- Unit serial number.
- Identifies unit electrical requirements.
- Lists correct operating charges of R-22 and refrigerant oil.
- Lists unit test pressures
- Identifies installation, operation and maintenance and service data literature.
- Lists drawing numbers for unit wiring diagrams.

Compressor Nameplate

The compressor nameplate provides the following information:

- Compressor model number.
- Compressor serial number.
- Compressor electrical characteristics.
- Utilization Range.
- Recommended refrigerant.

ASME Nameplate

The ASME Nameplate is different for the evaporators and condensers (RTWA only). The evaporator nameplate is located on the tubesheet, on the suction end. The insulation over the nameplate is intentionally left unglued, for ease in viewing the nameplate.

Each condensing shell has a nameplate located on the top of the shell, between the relief valve and the tubesheet. The nameplates are at opposite ends from each other.

General Information

		MODEL NUMBER				SERIAL NUMBER			
RATED VOLTAGE		MIN CKT AMPACITY		MAX FUSE OR BRKR (1)		MAX D.C. PRNT'N		REC DUAL-ELEMENT FUSE	
VOLT UTIL RANGE		CKT 1		CKT 2		CKT 1		CKT 2	
TYPE OF USE		VOLT-AC		HZ		PH		VA	
CPRSR MOTOR 1		3		RLA		Y LRA		X-L LRA	
CONTROL CIRCUIT		1		EVAP HEATER		1		REFRIGERANT DIL	
CPRSR MOTOR 2		3		TYPE/NUMBER		CHARGE CKT 1		LBS GAL	
CPRSR MOTOR 3		3		HP EA		FLA EA		CHARGE CKT 2	
CPRSR MOTOR 4		3		MIN HKD DESIGN PSIG FOR ANY RMT COND		REFRIGERANT CHARGE			
FAN MOTORS		3		QTY		HP EA		FLA EA	
DESIGN PRESSURES		HIGH SIDE		LOW SIDE		MIN HKD DESIGN PSIG FOR ANY RMT COND		REFRIGERANT CHARGE	
INSTALLATION, OPERATION, AND MAINTENANCE MANUALS									
FIELD WIRING DIAGRAM				ELECTRICAL DIAGRAMS (1) HACR TYPE CB REQUIRED BY NEC					
LAYOUT & SENSORS		P.1		P.4		P.7			
COMPONENT LOCATIONS		P.2		P.5		P.8			
		P.3		P.6		P.9			
<small> MANUFACTURED UNDER ONE OR MORE OF THE FOLLOWING U.S. PATENTS: 5,886,287; 5,711,749; 5,707,263; 5,645,177; 5,487,749; 5,005,006; 5,079,075; 5,037,608; 5,038,448; 5,064,032 CORRESPONDING FOREIGN PATENTS OWNED BY AMERICAN STANDARD INC.: 5,056,254; 5,078,151; 5,077,580; 5,123,226; 5,183,844; 5,231,846; 5,419,175; 5,522,884; 5,527,151; 5,570,043 The Trane Company, A Division of American Standard Inc. Made in the U.S.A. 0706-0049-0100 </small>									

Figure 1 Nameplates

Model Number Coding System

The model numbers for the unit and the compressors are comprised of numbers and letter which represent features of the equipment.

Each position, or group of positions, in the number is used to represent a feature. For example, Unit Voltage, contains the number "4". From the chart, it can be seen that a "4" in this position means that the unit voltage is 460/60/3.



General Information

The Series R Unit Model Number is as follows:

Model Number	RTW	A	070	4	Y	A0	1	C	1	D	O	V	F					
Digit Number	0					1												
Digit Position	1	2	3	4	5	6	7	8	9	0	1	2	3	4	5	6	7	8

Digit 1-2

Unit Model
RT Rotary Chiller

Digit 03

Unit Type
W Water Cooled
U Compressor Chiller (Use w/ Remote Condenser)

Digit 04

Development Sequence
A First Sequence

Digit 05, 06, 07

Nominal Capacity
070 70 Nominal Tons
080 80 Nominal Tons
090 90 Nominal Tons
100 100 Nominal Tons
110 110 Nominal Tons
125 125 Nominal Tons

Digit 08

Unit Voltage
A 200/60/3
C 230/60/3
D 380/60/3
K 380-415/50/3 Dual Voltage
4 460/60/3
5 575/60/3
S Special

Digit 09

Compressor Starter Type
Y Y-Delta Closed Transition
X X-Line (Across the Line)
S Special

Digit 10, 11

Design Sequence
AO First Sequence (Factory Input)

Digit 12

Evaporator Leaving Temperature
1 Standard 40 to 65 F
2 Low Temperature Process (0 to 39 F)
3 Ice-Making + 40 to 65 F Daytime
4 Ice-Making + 0 to 39 F Daytime
S Special

Digit 13

Condenser Configuration
C Standard Length, Copper Tubes, Std. Temp
D Long, Copper Tubes, Std. Temp
E Standard Efficiency, High Temp., Copper Tubes
F Long Condenser Shell, High Temp., Copper tubes
R Remote Condenser (RTUA)
S Special

Digit 14

Agency Listing
0 No Agency Listing
3 C-UL Listing

Digit 15

Control Interface
C Deluxe without Communication
D Deluxe with Communication
L LCI-C (LonTalk)

Digit 16

Chilled Water Reset
0 No Chilled Water Reset
1 Based on Return Water Temperature
2 Based on Outside Air Temperature

Digit 17

Compressor Volume Ratio
V Hi-Vi Application (If Digit 12 is 3 or if Digit 13 is E, F or R)
W Lo-Vi Application (If Digit 12 is 1 or 3 and if Digit 13 is C or D)

Digit 18 (up to Digit 24)

Miscellaneous Factory Installed Options
D Low Ambient Lockout Sensor (1)
F Power Disconnect
N Neoprene Isolators
R Remote Display Panel
S Special Custom Option
T Condenser Water Temp Sensors (2)
V Condenser Refrigerant Sensors (3)

Notes:

1. Either RTCA or non-RTCA Condensers.
2. RTWA only.
3. Use only with RTUA and non-RTCA condensers.



General Information

The Series R Unit Model Number is as follows:

Model Number	RTC	A	070	4	*	A0	*	B	3	*	*	A
Digit Number	0					1						
Digit Position	1 2 3	4	5 6 7	8	9	0 1	2	3	4	5	6	7

Digit 1-2

Unit Model

RT Rotary Chiller

Digit 3

Unit Type

C Air Cooled Condenser Unit

Digit 4

Development Sequence

A First Sequence

Digit 05, 06, 07

Nominal Capacity

070 70 Nominal Tons
 080 80 Nominal Tons
 090 90 Nominal Tons
 100 100 Nominal Tons
 110 110 Nominal Tons
 125 125 Nominal Tons

Digit 08

Unit Voltage

A 200/60/3
 C 230/60/3
 D 380/60/3
 J 346/50/3
 4 460/60/3
 5 575/60/3
 S Special
 G 200-230/60/3 Dual Voltage

Digit 09

Compressor Starter Type

0 Not Applicable

Digit 10, 11

Design Sequence

AO First Sequence (Factory Input)

Digit 12

Evaporator Leaving Temperature

0 Not Applicable

Digit 13

Condenser Coil Fin Material

A Aluminum
 2 Complete Coat
 4 Copper Fins
 S Special

Digit 14

Agency Listing

0 No Agency Listing
 3 C-UL Listing

Digit 15

Control Interface

0 Not Applicable

Digit 16

Chilled Water Reset

0 No Chilled Water Reset
 1 Based on Return Water Temperature
 2 Based on Outside Air Temperature
 3 Based on Zone Temperature

Digit 17

Miscellaneous Factory Installed Options

A Architectural Louvered Panels
 G Low Ambient Operation
 K Coil Protection
 M Access Guard
 N Neoprene Isolators



General Information

Storage

The RTWA/RTUA are designed for indoor installation only. Store the unit in a suitable enclosure, protected from the elements.

CAUTION

Equipment Damage!

Store the unit in an enclosed area, to prevent damage due to excessive water condensation.

The RTCA units are designed for outdoor installation. Extended storage of the outdoor unit prior to installation requires the following precautionary measures:

1. Store the outdoor unit in a secure area.
2. At least every three months (quarterly), check the holding charge to verify that the refrigerant circuits are intact. Contact a qualified service organization and the appropriate Trane sales office if there appears to be a problem.



Installation - Mechanical

Pre-Installation

Report any damage incurred during handling or installation to the Trane sales office immediately. An Installation Check Sheet is provided at the end of the Section "[Installation - Electrical](#)".

Location Requirements

Noise Considerations

Locate the RTWA/RTUA unit away from sound sensitive areas. If required, install rubber vibration isolators in all water piping and use flexible electrical conduit. Refer to Paragraph "[Unit Isolation and Leveling](#)" on [Page 27](#), for instructions on mounting isolators under the unit. Consult an acoustical engineer for critical applications.

Foundation

Provide rigid, non-warping mounting pads or a concrete foundation of sufficient strength and mass to support the applicable operating weight (i.e., including completed piping, and full operating charges of refrigerant, oil and water). Refer to [Tables 1, 3 and 4](#) for unit operating weights. Once in place, the unit must be level within 1/4" (6.4 mm) over its length and width. The Trane Company is not responsible for equipment problems resulting from an improperly designed or constructed foundation.

Clearances

Provide enough space around the unit to allow the installation and maintenance personnel unrestricted access to all service points. Refer to submittal drawings for the unit dimensions, to provide sufficient clearance for the opening of control panel doors and unit service. Refer to [Figures 3 to 6, 8, 9 and 11](#) for minimum clearances. In all cases, local codes which require additional clearances will take precedence over these recommendations.

NOTE: If the unit configuration requires a variance to the clearance dimensions, contact your Trane Sales Office Representative. Also refer to Trane Engineering Bulletins for application information on RTWA, RTUA and RTCA chillers.

Rigging

The Model RTWA/RTUA chiller should be moved by lifting, if the optional skid is removed. The RTCA should always be moved by lifting.

Refer to [Figures 2, 7 and 10](#) for typical unit lifting and operating weights. Refer to the rigging diagram that ships with each unit for specific "per unit" weight data.



Installation - Mechanical

⚠ WARNING **Heavy Objects!**

Do not use cables (chains or slings) except as shown. Each of the cables (chains or slings) used to lift the unit must be capable of supporting the entire weight of the unit. Lifting cables (chains or slings) may not be of the same length. Adjust as necessary for even unit lift. Other lifting arrangements may cause equipment or property-only damage. Failure to properly lift unit may result in death or serious injury. See details below.

Lifting Procedure

Attach chains or cables to lifting beam. The total lifting weight, lifting weight distribution and required lifting beam dimensions are shown in [Figures 2, 7](#) and [10](#) and on the rigging diagram shipped with each unit. Lifting beam crossbars must be positioned so lifting cables do not contact the sides of the unit.

Installation - Mechanical

X LINE STARTER PANEL				Y DELTA STARTER PANEL				X LINE STARTER PANEL				Y DELTA STARTER PANEL						
UNIT SIZE	STD. LENGTH COND			TOTAL WEIGHT LBS	CG LOCATION	X	Y	Z	UNIT SIZE	STD. LENGTH COND			TOTAL WEIGHT KG	CG LOCATION	X	Y	Z	
	X	Y	Z							X	Y	Z						
70	48.1	15.7	31.1	4205	70	48.2	16.5	30.9	4485	70	(1221.7)	(398.8)	(789.9)	1907	(1224.3)	(419.1)	(784.9)	2034
80	48.1	15.7	31.0	4251	80	48.2	16.5	30.9	4531	80	(1221.7)	(398.8)	(787.4)	1928	(1224.3)	(419.1)	(784.9)	2055
90	48.6	15.7	31.1	4405	90	48.6	16.5	31.0	4685	90	(1183.6)	(388.8)	(789.9)	1988	(1234.4)	(419.1)	(787.4)	2125
100	48.1	15.5	31.2	4559	100	48.5	16.3	31.1	4839	100	(1221.7)	(393.7)	(792.5)	2088	(1231.9)	(414.0)	(789.9)	2195
110	48.4	15.4	30.6	4764	110	48.5	16.2	30.5	5044	110	(1229.4)	(391.2)	(777.2)	2161	(1231.9)	(411.5)	(774.7)	2288
125	48.4	15.4	30.4	4834	125	48.5	16.1	30.3	5114	125	(1229.4)	(391.2)	(772.2)	2193	(1231.9)	(408.9)	(769.6)	2320
LONG LENGTH COND				LONG LENGTH COND				LONG LENGTH COND				LONG LENGTH COND						
70	47.7	15.6	31.1	4368	70	47.8	16.4	30.9	4648	70	(1211.6)	(386.2)	(789.9)	1981	(1214.1)	(416.6)	(784.9)	2108
80	47.7	15.6	31.0	4422	80	47.8	16.4	30.9	4702	80	(1211.6)	(386.2)	(787.4)	2006	(1214.1)	(416.6)	(784.9)	2133
90	48.2	15.6	31.1	4607	90	48.2	16.4	31.0	4887	90	(1224.3)	(396.2)	(789.9)	2090	(1224.3)	(416.6)	(787.4)	2217
100	47.8	15.4	31.2	4791	100	47.8	16.1	31.1	5071	100	(1214.1)	(391.2)	(792.5)	2173	(1214.1)	(408.9)	(789.9)	2300
110	48.3	15.3	30.6	5003	110	48.4	16.0	30.5	5283	110	(1226.8)	(388.6)	(777.2)	2269	(1229.4)	(406.4)	(774.7)	2396
125	48.3	15.2	30.4	5080	125	48.4	15.9	30.4	5360	125	(1226.8)	(386.1)	(772.2)	2304	(1229.4)	(403.9)	(772.2)	2431

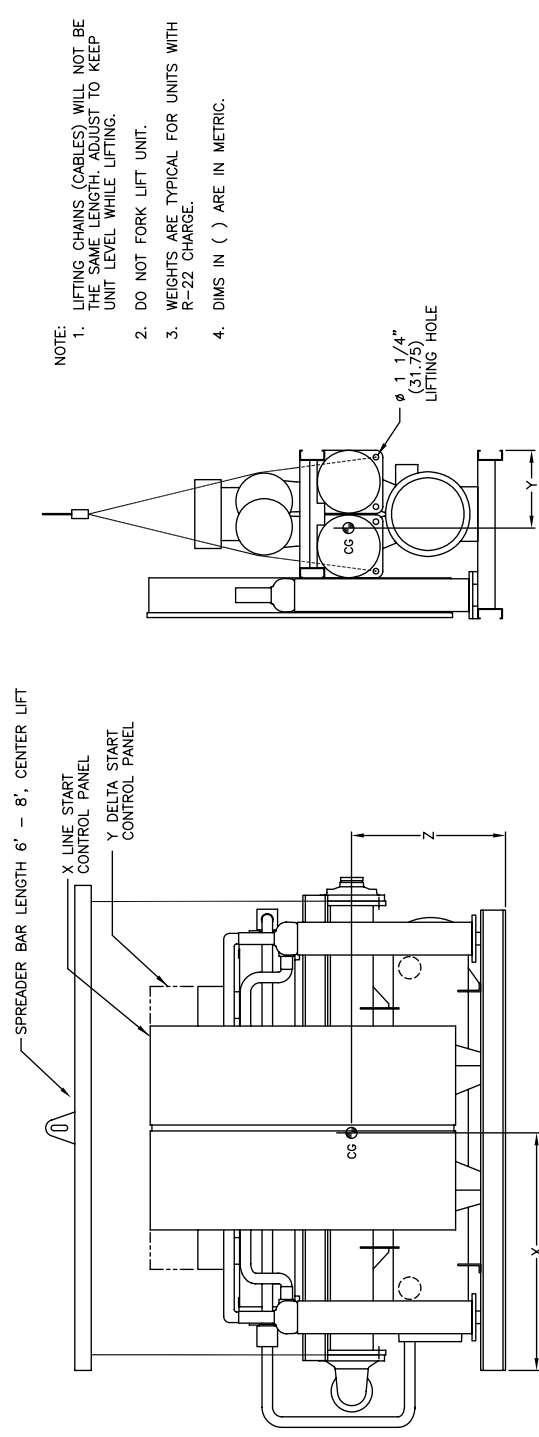

Figure 2 Rigging and Lifting for RTWA Units

Installation - Mechanical

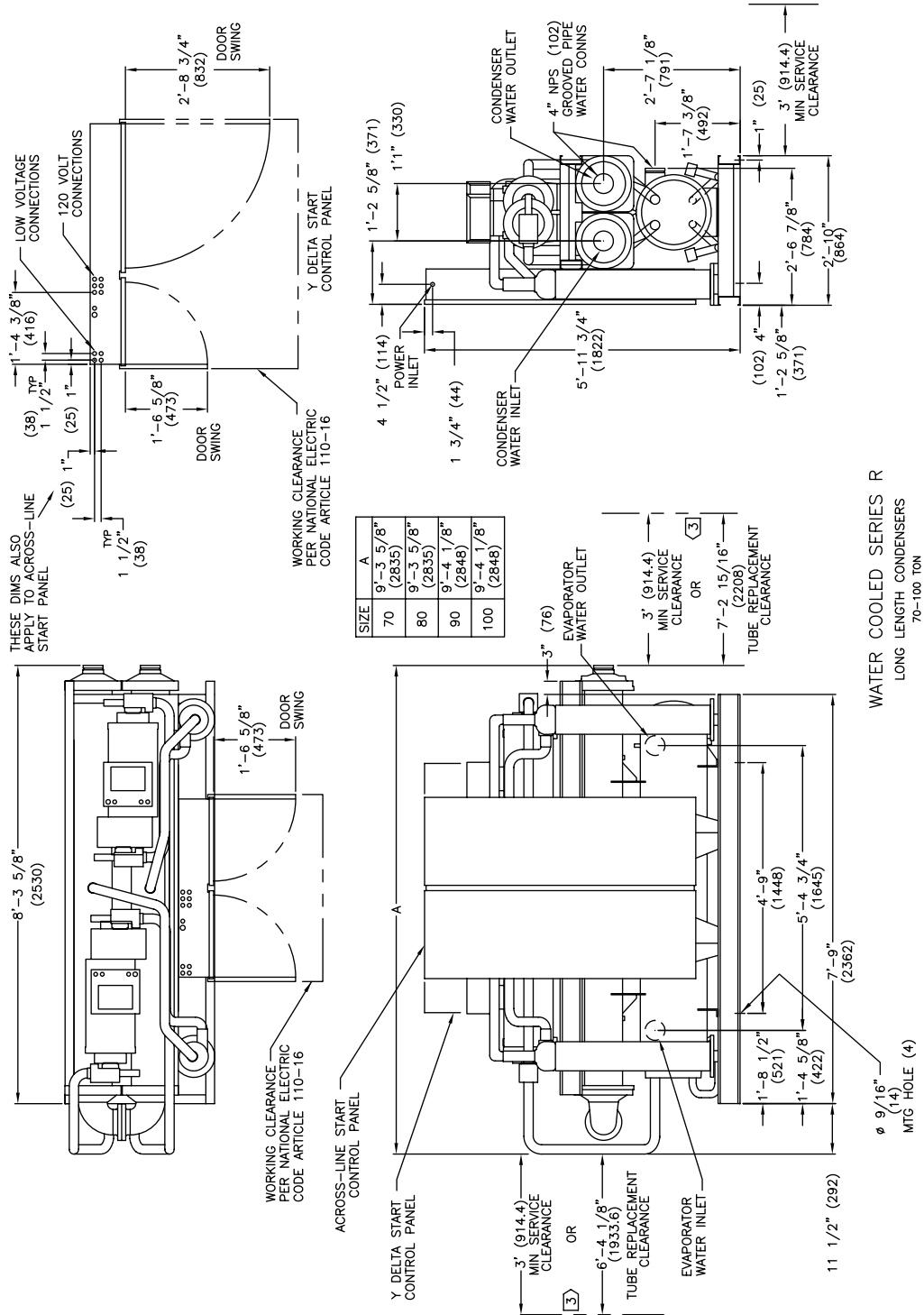

Figure 3 Dimension and Clearances for RTWA Unit Standard Length Condensers – 70-100 Tons

Installation - Mechanical

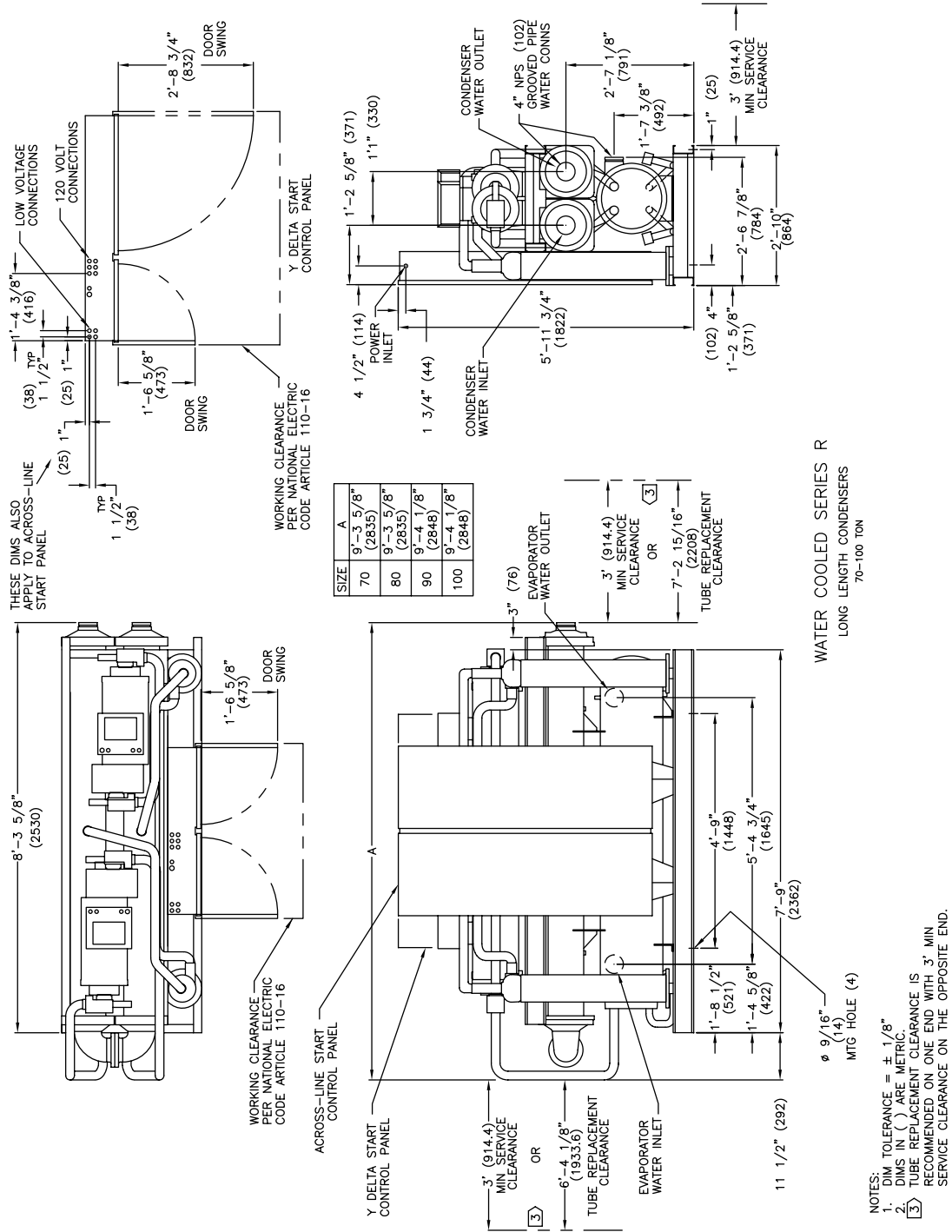
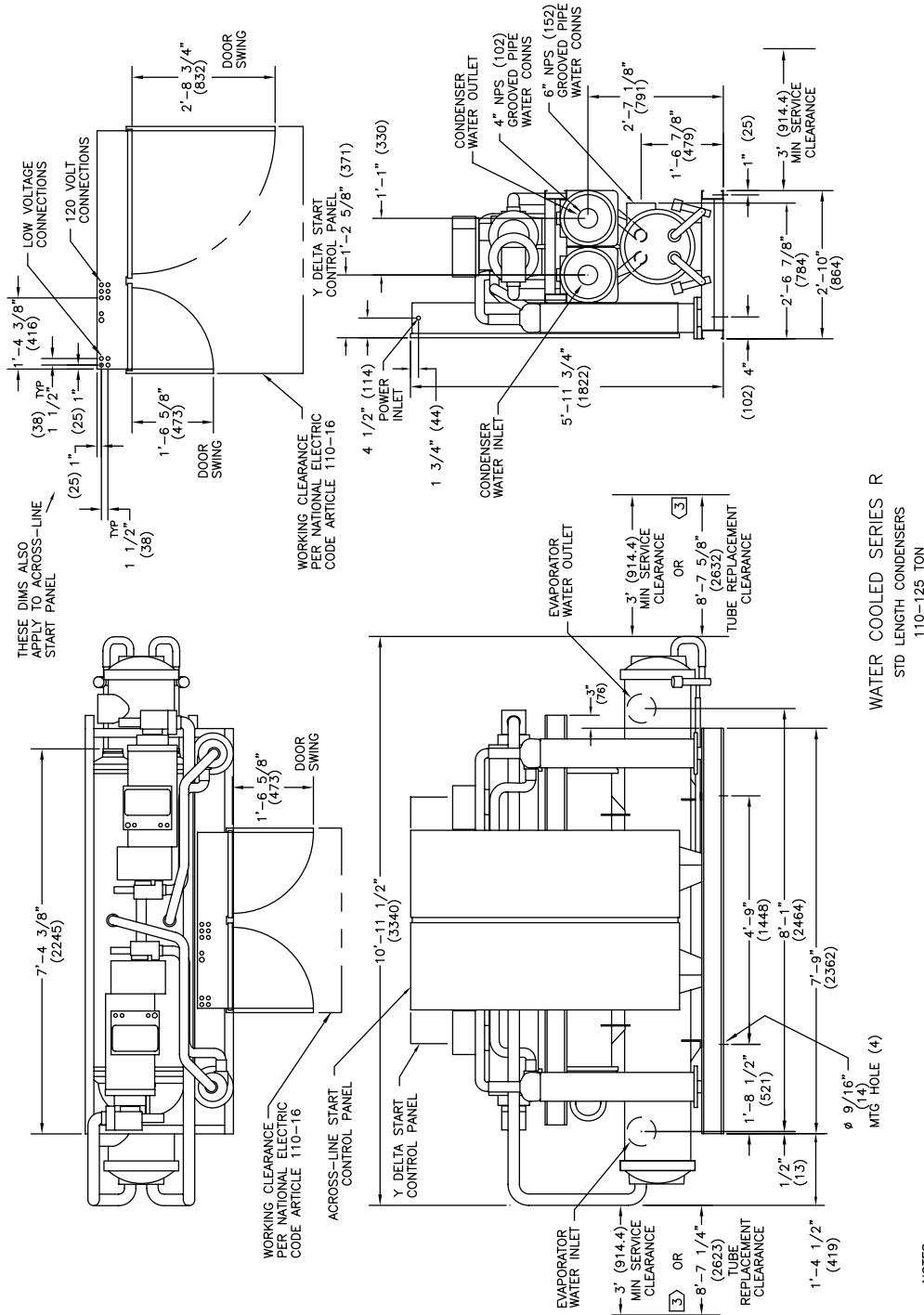

Figure 4 Dimension and Clearances for RTWA Unit Long Length Condensers – 70-100 Tons

Installation - Mechanical



- NOTES:
1. DIM TOLERANCE = ± 1/8"
 2. DIMS IN () ARE METRIC.
 3. TUBE REPLACEMENT CLEARANCE IS RECOMMENDED ON ONE END WITH 3" MIN SERVICE CLEARANCE ON THE OPPOSITE END.

Figure 5 Dimension and Clearances for RTWA Unit Standard Length Condensers—110-125 Tons

Installation - Mechanical

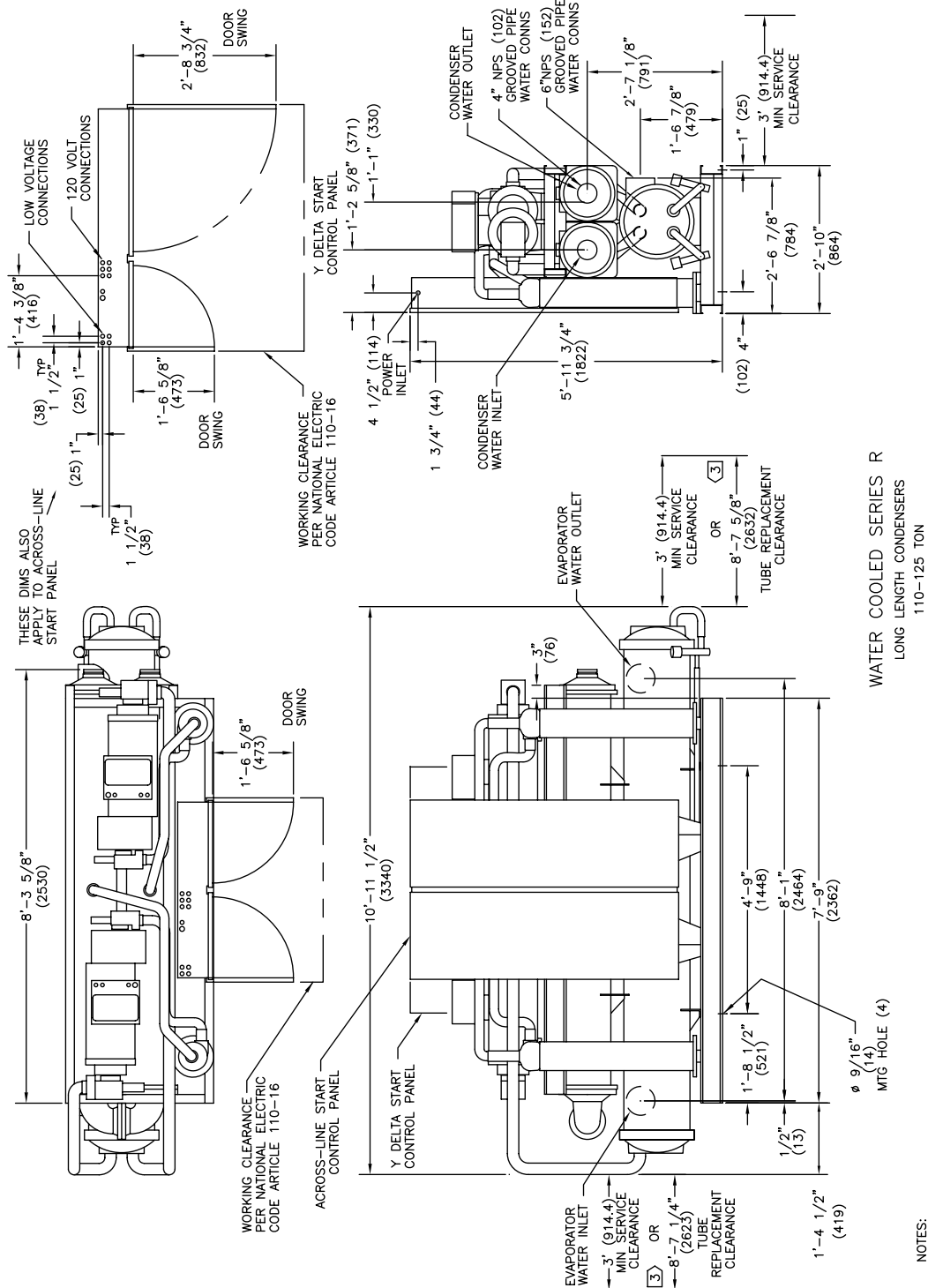

Figure 6 Dimension and Clearances for RTWA Unit Long Length Condensers-110-125 Tons

Installation - Mechanical

X LINE STARTER PANEL				Y DELTA STARTER PANEL					
UNIT SIZE	CG LOCATION			TOTAL WEIGHT LBS	UNIT SIZE	CG LOCATION			TOTAL WEIGHT LBS
	X	Y	Z			X	Y	Z	
70	48.5	18.0	31.5	3194	70	48.5	17.0	31.3	3474
80	48.5	18.0	31.4	3220	80	48.5	17.0	31.2	3500
90	49.2	18.1	31.5	3329	90	49.1	17.1	31.3	3609
100	48.5	18.2	31.6	3421	100	48.5	17.3	31.4	3701
110	48.5	18.2	31.6	3437	110	48.5	17.3	31.4	3717
125	48.5	18.2	31.6	3437	125	48.5	17.3	31.4	3717
	MILLIMETERS			KG		MILLIMETERS			KG
70	(1231.9)	(457.2)	(800.1)	1449	70	(1231.9)	(431.8)	(795.0)	1576
80	(1231.9)	(457.2)	(797.6)	1461	80	(1231.9)	(431.8)	(792.5)	1588
90	(1249.7)	(459.7)	(800.1)	1510	90	(1247.1)	(434.3)	(795.0)	1637
100	(1231.9)	(462.3)	(802.6)	1552	100	(1231.9)	(439.4)	(797.6)	1679
110	(1231.9)	(462.3)	(802.6)	1559	110	(1231.9)	(439.4)	(797.6)	1686
125	(1231.9)	(462.3)	(802.6)	1559	125	(1231.9)	(439.4)	(797.6)	1686

- NOTE:
- LIFTING CHAINS (CABLES) WILL NOT BE THE SAME LENGTH. ADJUST TO KEEP UNIT LEVEL WHILE LIFTING.
 - DO NOT FORK LIFT UNIT.
 - WEIGHTS ARE TYPICAL FOR UNITS WITH R-22 CHARGE.
 - DIMS IN () ARE IN MILLIMETERS.

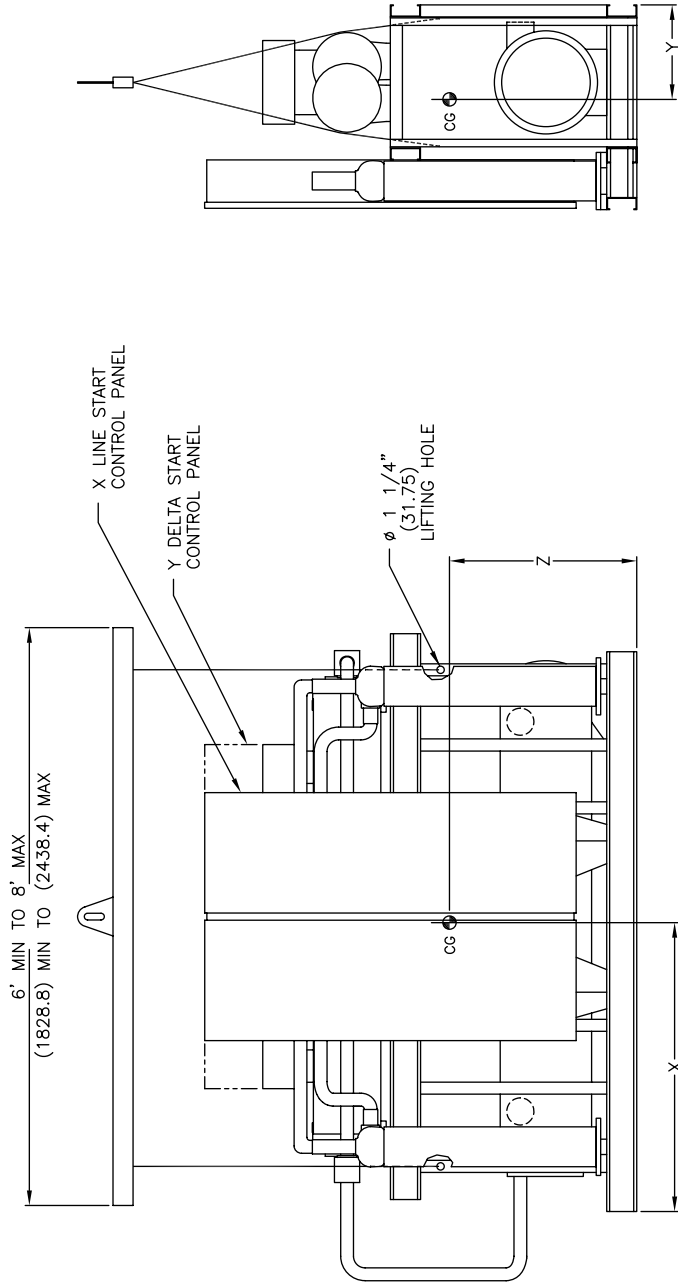

Figure 7 Rigging and Lifting for RTUA Units

Installation - Mechanical

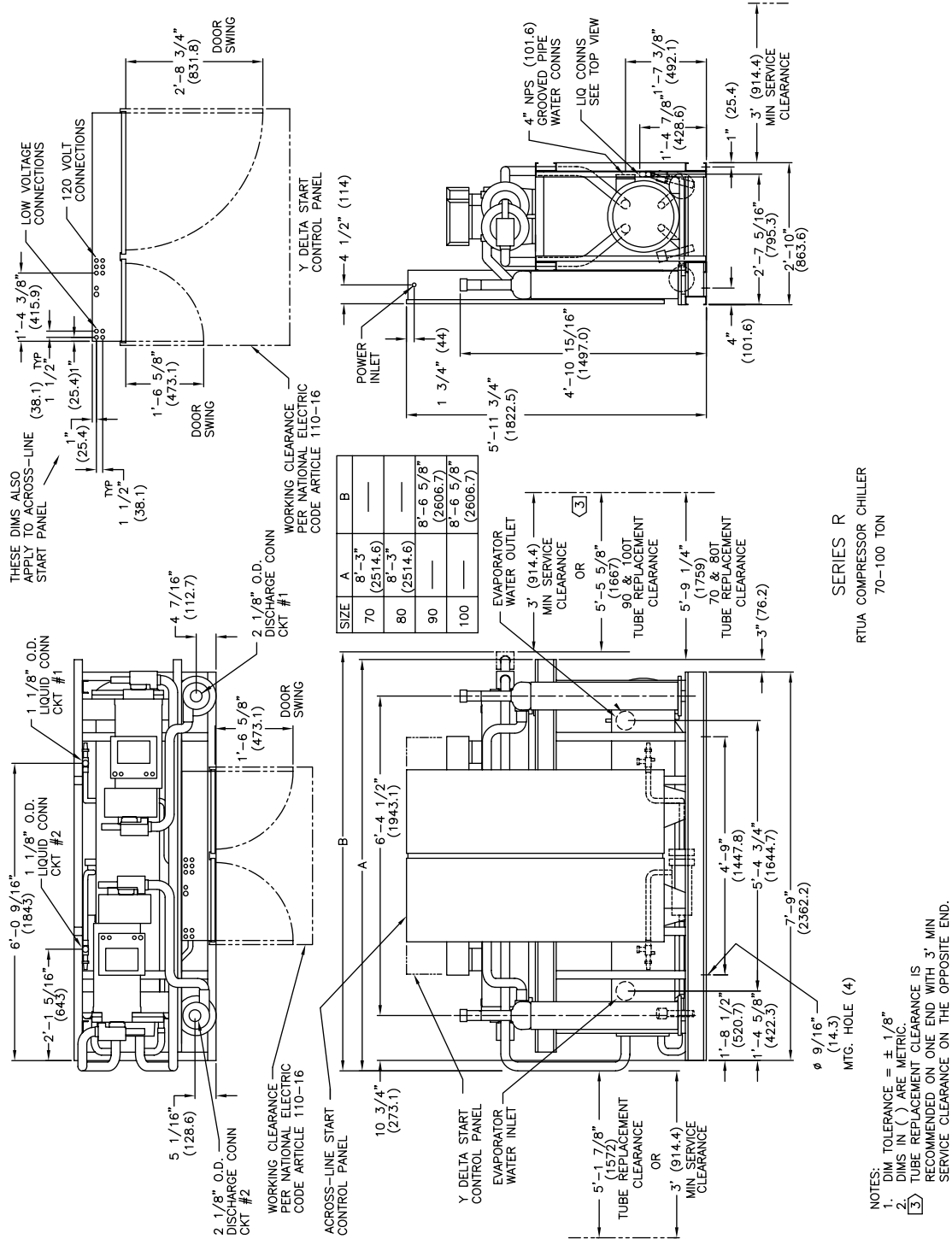
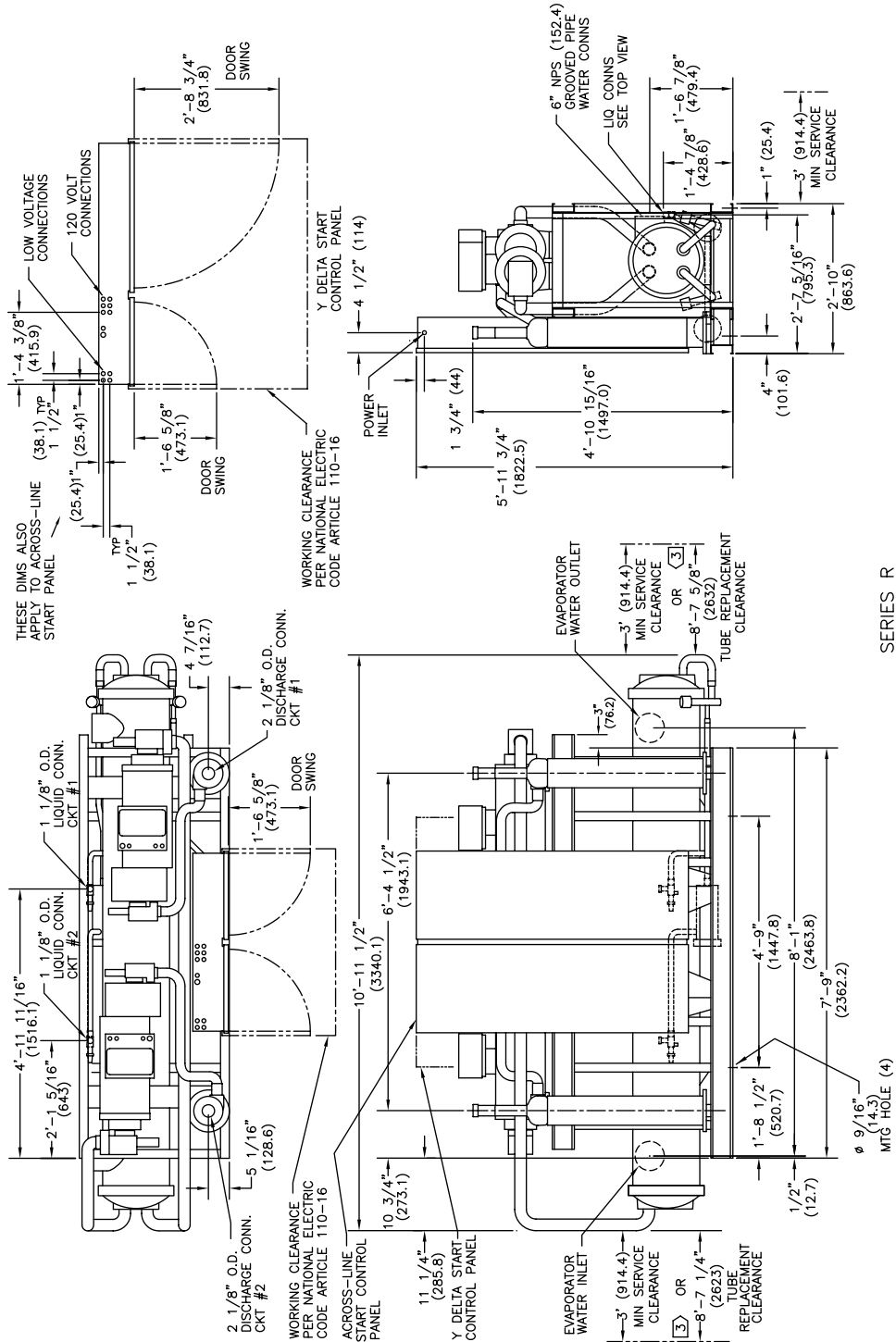

Figure 8 Dimension and Clearances for RTUA Compressor Chiller – 70-100 Tons

Installation - Mechanical



SERIES R
RTUA COMPRESSOR CHILLER
110-125 TON

- NOTES:
1. DIM TOLERANCE = ± 1/8"
2. DIMS IN () ARE METRIC.
3. TUBE REPLACEMENT CLEARANCE IS RECOMMENDED ON ONE END WITH 3" MIN SERVICE CLEARANCE ON THE OPPOSITE END.

Figure 9 Dimension and Clearances for RTUA Compressor Chiller – 100-125 Tons

Installation - Mechanical

- NOTES:
1. LIFTING CHAINS (CABLES) WILL NOT BE THE SAME LENGTH. ADJUST TO KEEP UNIT LEVEL WHILE LIFTING.
 2. DO NOT FORK LIFT UNIT.
 3. WEIGHTS ARE TYPICAL FOR UNITS WITH R-22 CHARGE.
 4. DIMENSION IN () ARE IN METRIC.

UNIT SIZE	LIFTING WEIGHTS				TOTAL WEIGHTS	CG LOCATIONS		
	W1	W2	W3	W4		X	Y	Z
70	667 (303)	642 (291)	1504 (682)	1448 (657)	4262 (1933)	94.2 (2.393)	43.3 (1.100)	50.4 (1.280)
80	671 (304)	646 (293)	1513 (686)	1457 (661)	4287 (1945)	94.2 (2.393)	43.3 (1.100)	50.2 (1.275)
90	667 (303)	606 (275)	1615 (733)	1469 (666)	4357 (1976)	96.1 (2.441)	42.1 (1.069)	50.7 (1.288)
100	641 (291)	619 (281)	1637 (743)	1578 (716)	4475 (2030)	97.5 (2.477)	43.3 (1.100)	50.8 (1.290)
110	923 (419)	840 (381)	1554 (705)	1413 (641)	4730 (2146)	105.3 (2.675)	42.1 (1.069)	52.5 (1.333)
125	877 (398)	848 (385)	1593 (723)	1540 (699)	4858 (2204)	108.0 (2.743)	43.4 (1.102)	52.4 (1.331)

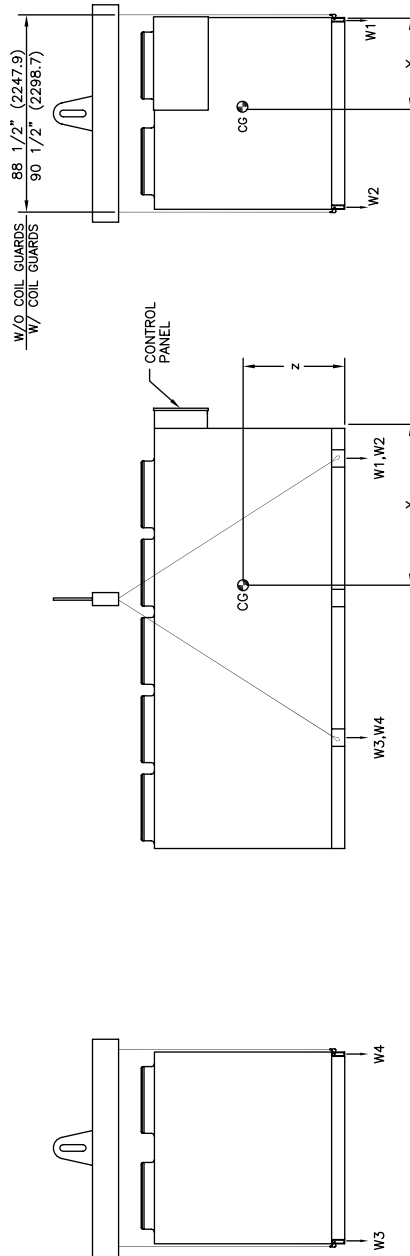

SERIES R AIR COOLED CONDENSER™
 ROTARY LIQUID CHILLER®
 RIGGING
 RTCA 70 - 125 TON

Figure 10 Rigging and Lifting for RTCA Condenser

Installation - Mechanical

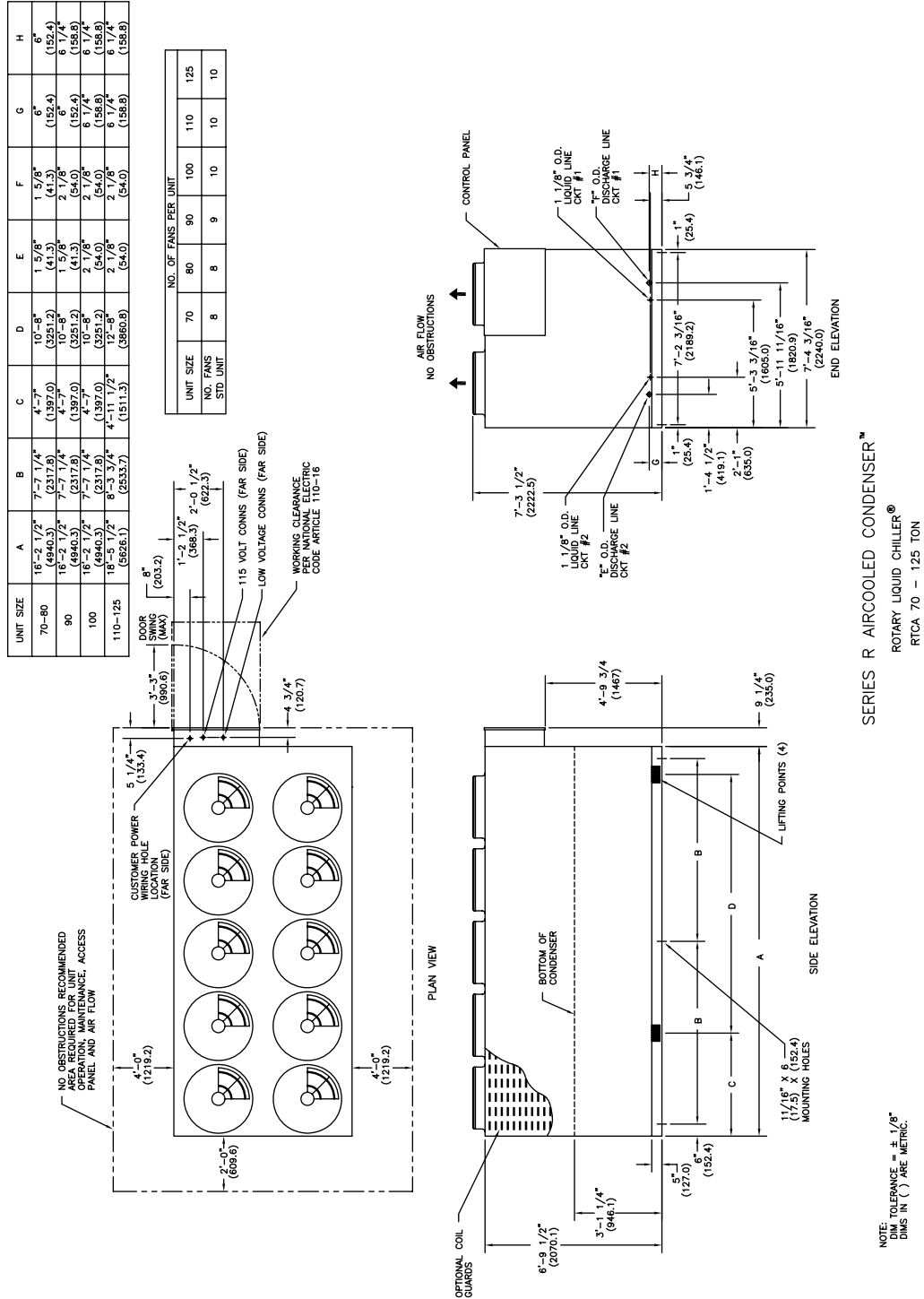

SERIES R AIRCOOLED CONDENSER
 ROTARY LIQUID CHILLER®
 RTCA 70 - 125 TON

NOTE: TOLERANCE = ± 1/8"
 DIMS IN () ARE METRIC.

Figure 11 Dimensions and Clearances for RTCA Condenser



Installation - Mechanical

Unit Isolation and Leveling

Mounting

Construct an isolated concrete pad for the unit or provide concrete footings at each of the four unit mounting points. Mount the unit directly to the concrete pads or footings.

Level the unit using the base rail as a reference. The unit must be level within 1/4" over the entire length. Use shims as necessary to level the unit.

Isolators

The RTWA, RTUA and RTAC units should use neoprene isolators. Install isolators at each unit mounting point.

Neoprene Isolator Installation.

Install the optional neoprene isolators at each mounting location. Isolators are identified by part number and color.

1. Secure the isolators to the mounting surface, using the mounting slots in the isolator base plate, as shown in [Figure 12](#), [13](#) and [14](#). Do not fully tighten the isolator mounting bolts at this time.
2. Align the mounting holes in the base of the unit, with the threaded positioning pins on the top of the isolators.

NOTE: RTWA/RTUA mount front isolators on cross rails not long rails for best performance.

3. Lower the unit on to the isolators and secure the isolator to the unit with a nut. Maximum isolator deflection should be approximately 1/4".
4. Level the unit carefully. Refer to "Leveling". Fully tighten the isolator mounting bolts.

Installation - Mechanical

SPECIFICATIONS:
 TYPE: RDP-4
 COLOR: BLACK
 MAX LOAD EA: 1500 LBS (680 KG)
 DEFLECTION: .50"
 MATL: NEOPRENE
 P/N: X1014-0305-610

UNIT SIZE	LOC 1	LOC 2	LOC 3	LOC 4	TOTAL WEIGHT
	MTG WT. (APPROX LBS)				
70	1123	1081	1049	1010	4262
80	1129	1087	1055	1016	4287
90	1155	1051	1126	1025	4357
100	1136	1096	1142	1101	4475
110	1302	1185	1174	1068	4730
125	1267	1225	1203	1163	4858
	MTG WT. (APPROX KG)				
70	509	490	476	458	1933
80	512	493	479	461	1945
90	524	477	511	465	1976
100	515	497	518	500	2030
110	591	538	533	485	2146
125	575	556	546	528	2204

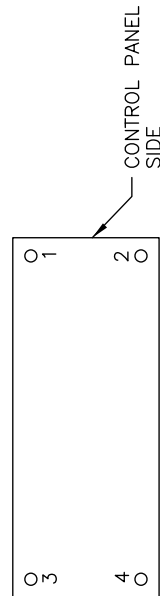
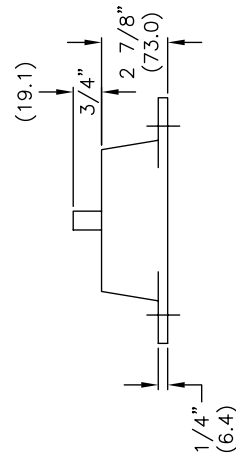
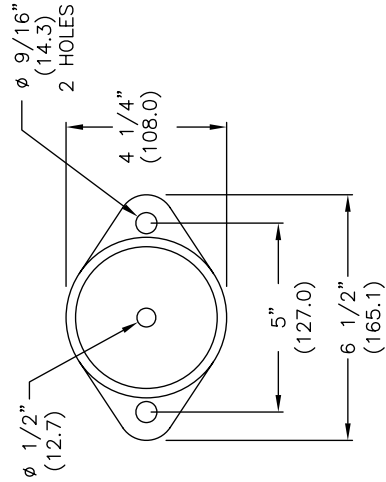

SERIES R AIRCOOLED CONDENSER
 ISOLATORS
 70 - 125 TON

Figure 12 Neoprene Isolator Placement for Typical RTWA Package Units 70-125 Ton

Installation - Mechanical

SPECIFICATIONS:
TYPE: RDP-3

COLOR: GRAY

DEFLECTION: .50"

MATL: NEOPRENE

P/N: X1014-0305-600

ACROSS-LINE STARTER PANEL					Y DELTA STARTER PANEL				
UNIT SIZE	LOC 1	LOC 2	LOC 3	LOC 4	UNIT SIZE	LOC 1	LOC 2	LOC 3	LOC 4
	MTG WT (APPROX LBS)					MTG WT (APPROX LBS)			
70	794	727	798	731	70	927	735	931	738
80	797	731	800	734	80	929	738	933	741
90	836	770	799	736	90	970	776	930	745
100	828	776	832	780	100	961	783	965	787
110	865	829	869	832	110	998	836	1002	839
125	865	829	869	832	125	998	836	1002	839
	MTG WT (APPROX KG)					MTG WT (APPROX KG)			
70	360	330	362	332	70	420	333	422	335
80	362	332	363	333	80	421	335	423	336
90	379	349	362	334	90	440	352	422	338
100	376	352	377	354	100	436	355	438	357
110	392	376	394	377	110	453	379	454	381
125	392	376	394	377	125	453	379	454	381

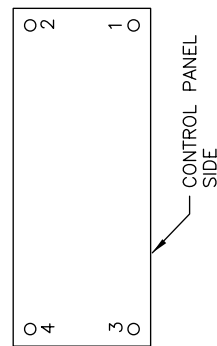
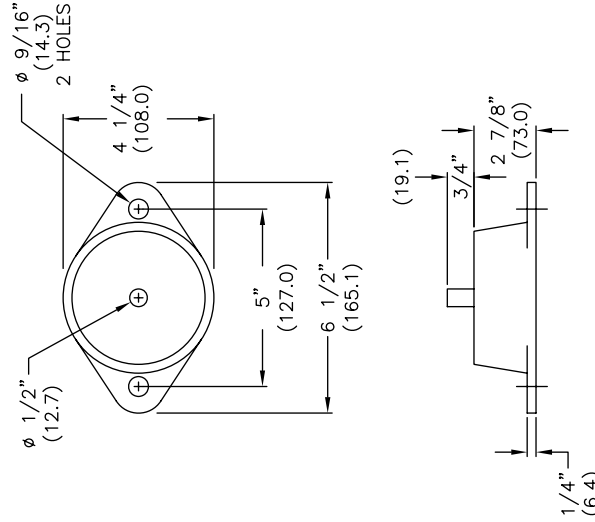

SERIES R COMPRESSOR CHILLER
RTUA ISOLATORS
70 - 125 TON

Figure 13 Neoprene Isolator Placement for Typical RTUA Package Units 70-125 Ton

Installation - Mechanical

SPECIFICATIONS:
 TYPE: RDP-4
 COLOR: BLACK
 MAX LOAD EA: 1500 LBS (680 KG)
 DEFLECTION: .50"
 MATL: NEOPRENE
 P/N: X1014-0305-610

UNIT SIZE	LOC 1	LOC 2	LOC 3	LOC 4	TOTAL WEIGHT
	MTG WT (APPROX LBS)				
70	1123	1081	1049	1010	4262
80	1129	1087	1055	1016	4287
90	1155	1051	1126	1025	4357
100	1136	1096	1142	1101	4475
110	1302	1185	1174	1068	4730
125	1267	1225	1203	1163	4858
MTG WT (APPROX KG)					
70	509	490	476	458	1933
80	512	493	479	461	1945
90	524	477	511	465	1976
100	515	497	518	500	2030
110	591	538	533	485	2146
125	575	556	546	528	2204

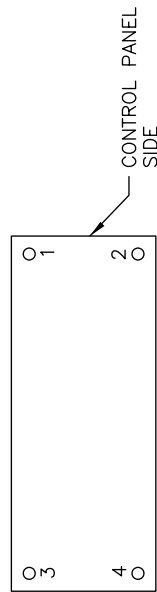
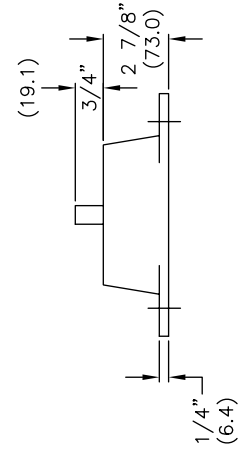
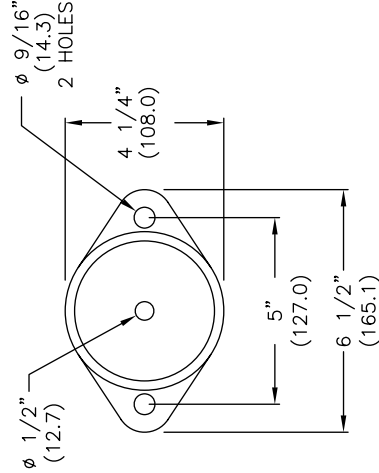

SERIES R AIRCOOLED CONDENSER
 ISOLATORS
 70 - 125 TON

Figure 14 Neoprene Isolator Placement for Typical RTCA Package Units 70-125 Ton



Installation - Mechanical

Water Piping

Thoroughly flush all water piping to the RTWA/RTUA unit before making the final piping connections to the unit.

CAUTION

Equipment Damage!

If using an acidic commercial flushing solution, construct a temporary bypass around the unit to prevent damage to internal components of the evaporator.

CAUTION

Proper Water Treatment!

The use of untreated or improperly treated water in a Chiller may result in scaling, erosion, corrosion, algae or slime. It is recommended that the services of a qualified water treatment specialist be engaged to determine what water treatment, if any, is required. Trane assumes no responsibility for equipment failures which result from untreated or improperly treated water, or saline or brackish water.

CAUTION

Use Piping Strainers!

To prevent evaporator or condenser damage, pipe strainers must be installed in the water supplies to protect components from water born debris. Trane is not responsible for equipment-only-damage caused by water born debris.

Evaporator Water Piping (for RTWA and RTUA Units Only)

[Figure 15](#) illustrates typical evaporator piping components. Components and layout will vary slightly, depending on the location of connections and the water source.

CAUTION

Equipment Damage!

The chilled water connections to the evaporator are to be grooved connections. Do not attempt to weld these connections, as the heat generated from welding can cause internal damage to the evaporator.

The chilled water connections are on the back of the unit, when facing the control panel.

A vent is provided on the top of the evaporator at the return end. Be sure to provide additional vents at high points in the piping to bleed air from the chilled water system. Install necessary pressure gauges to monitor the entering and leaving chilled water pressures.

Installation - Mechanical

CAUTION Equipment Damage!

To prevent damage to chilled water components, do not allow evaporator pressure (maximum working pressure) to exceed 215 psig.

Provide shutoff valves in lines to the gauges to isolate them from the system when they are not in use. Use rubber vibration eliminators to prevent vibration transmission through the water lines.

If desired, install thermometers in the lines to monitor entering and leaving water temperatures. Install a balancing valve in the leaving water line to control water flow balance. Install shutoff valves on both the entering and leaving water lines so that the evaporator can be isolated for service.

A pipe strainer must be installed in the entering water line to prevent water-borne debris from entering the evaporator.

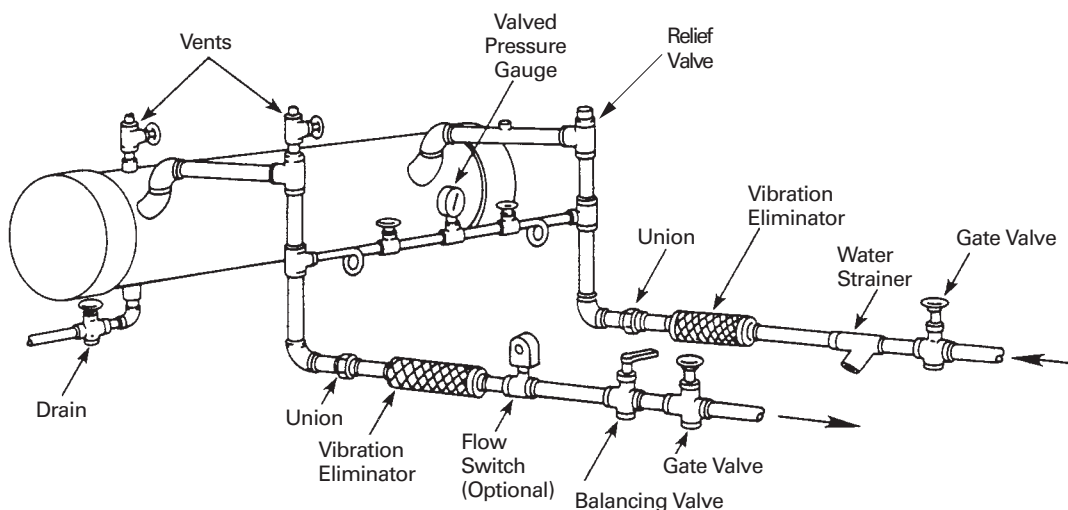

Figure 15 Suggested Piping for Typical RTWA Evaporator

Evaporator Piping Components

"Piping components" include all devices and controls used to provide proper water system operation and unit operating safety. These components and their general locations are given below.

Entering Chilled Water Piping

- Air vents (to bleed air from system).
- Water pressure gauges with shutoff valves.
- Vibration eliminators.
- Shutoff (isolation) valves.
- Thermometers (if desired).
- Cleanout tees.
- Relief valve.
- Pipe strainer.



Installation - Mechanical

CAUTION

Use Piping Strainers!

To prevent evaporator or condenser damage, pipe strainers must be installed in the water supplies to protect components from water born debris. Trane is not responsible for equipment-only-damage caused by water born debris.

Leaving Chilled Water Piping

- Air vents (to bleed air from system).
- Water pressure gauges with shutoff valves.
- Vibration eliminators.
- Shutoff (isolation) valves.
- Thermometers.
- Cleanout tees.
- Balancing valve.
- Flow Switch (If desired).

CAUTION

Equipment Damage!

To prevent evaporator damage, do not exceed 215 psig (14.6 bar) evaporator water pressure.

Evaporator Drain

A 3/4" drain connection is located under the outlet end of the evaporator. This may be connected to a suitable drain to permit evaporator drainage during unit servicing. A shutoff valve must be installed on the drain line.

Chilled Water Flow Switch

On RTWA and RTUA units, chilled water flow protection is provided by the UCM without the need for a chilled water flow switch. A flow switch for chilled water is strictly discretionary but if not installed, a signal must be sent to the chiller to indicate that water flow has been established, eg. chilled water pump motor starter auxiliary contacts, building automation system, etc.

If additional chilled water flow protection is desired, use a field-installed flow switch or differential pressure switch, with the pump motor starter auxiliary contacts, to sense system water flow. Install and wire the flow switch in series with the chilled water pump motor starter auxiliaries (refer to Paragraph "[Interconnecting Wiring](#)" on Page 62).

Specific connection and schematic wiring diagrams are shipped with the unit. Some piping and control schemes, particularly those using a single water pump for both chilled and hot water, must be analyzed to determine how and or if a flow sensing device will provide desired operation.

Follow the manufacturer's recommendations for selection and installation procedures. General guidelines for flow switch installation are outlined below:

1. Mount the switch upright, with a minimum of 5 pipe diameters of straight horizontal run on each side. Do not install close to elbows, orifices or valves.



Installation - Mechanical

NOTE: The arrow on the switch must point in the direction of flow.

2. To prevent switch fluttering, remove all air from the water system.
3. Adjust the switch to open when water flow falls below nominal. Evaporator data is shown in [Figure 16](#). Refer to Tables 1 to 3 (General Data) for minimum flow recommendations. Flow switch contacts are closed on proof of water flow.
4. Install a pipe strainer in the entering evaporator water line to protect components from water-borne debris.

Installation - Mechanical

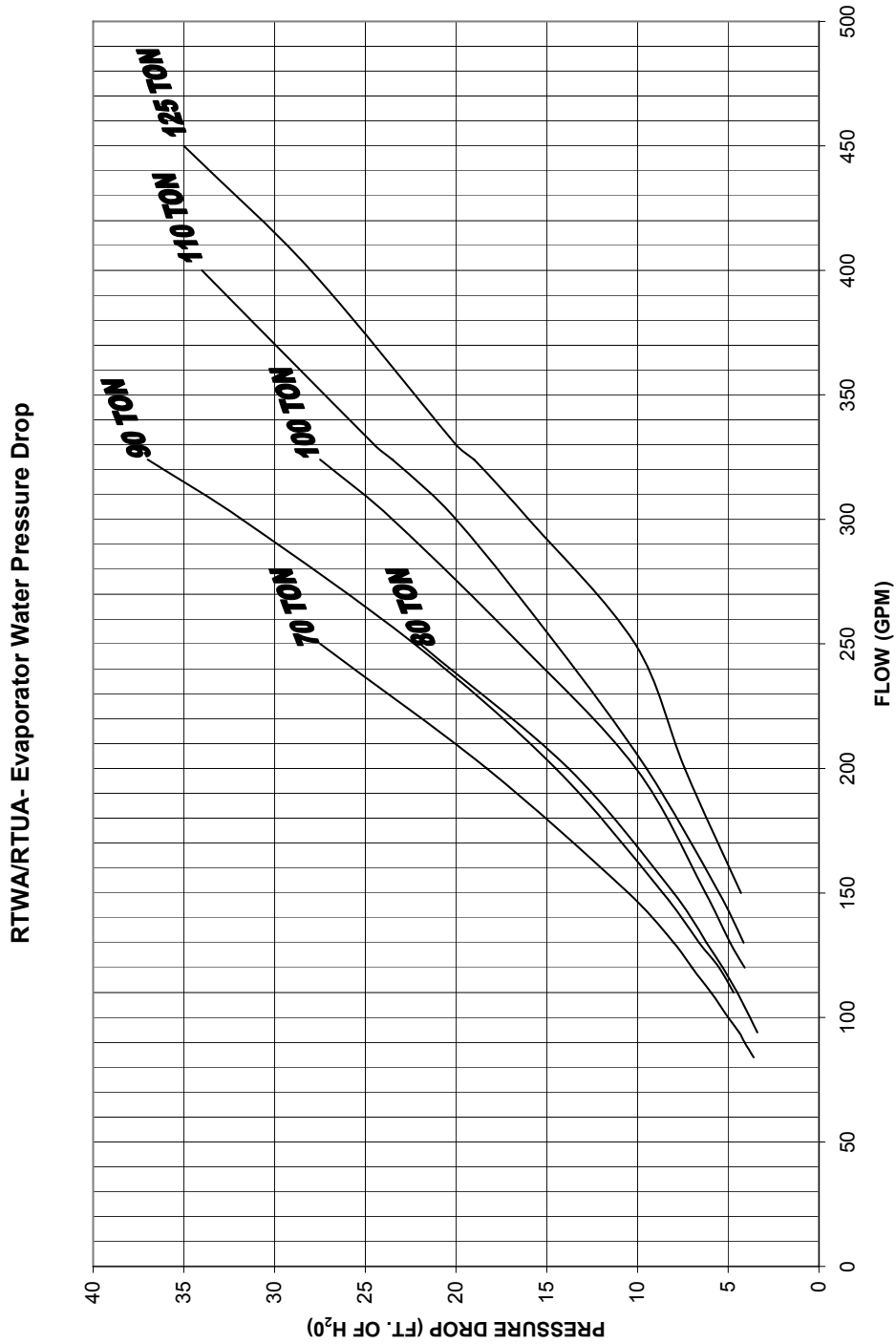

Figure 16 RTWA/RTUA – Evaporator Water Pressure Drop

Installation - Mechanical

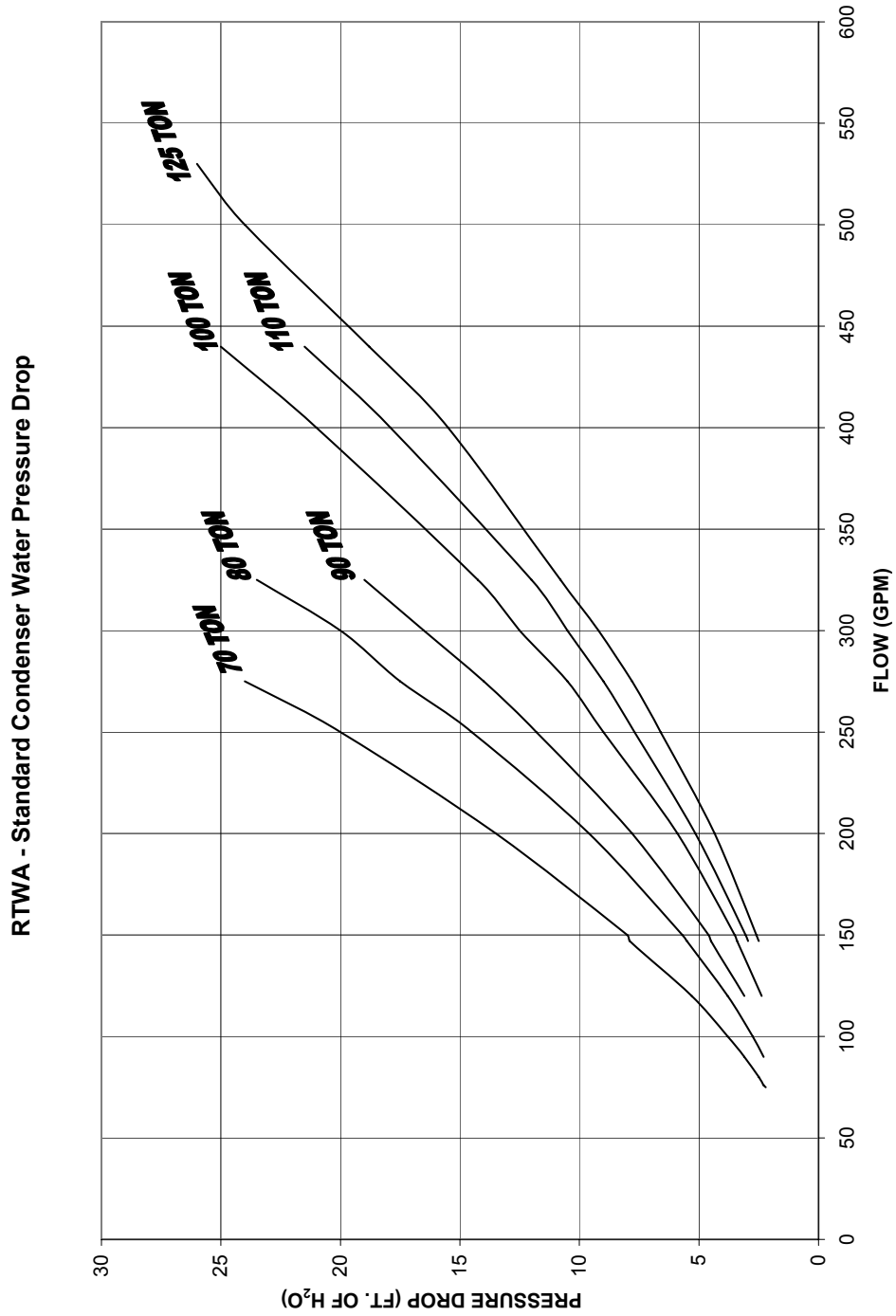

Figure 17 RTWA – Standard Pressure Water Pressure Drop

Installation - Mechanical

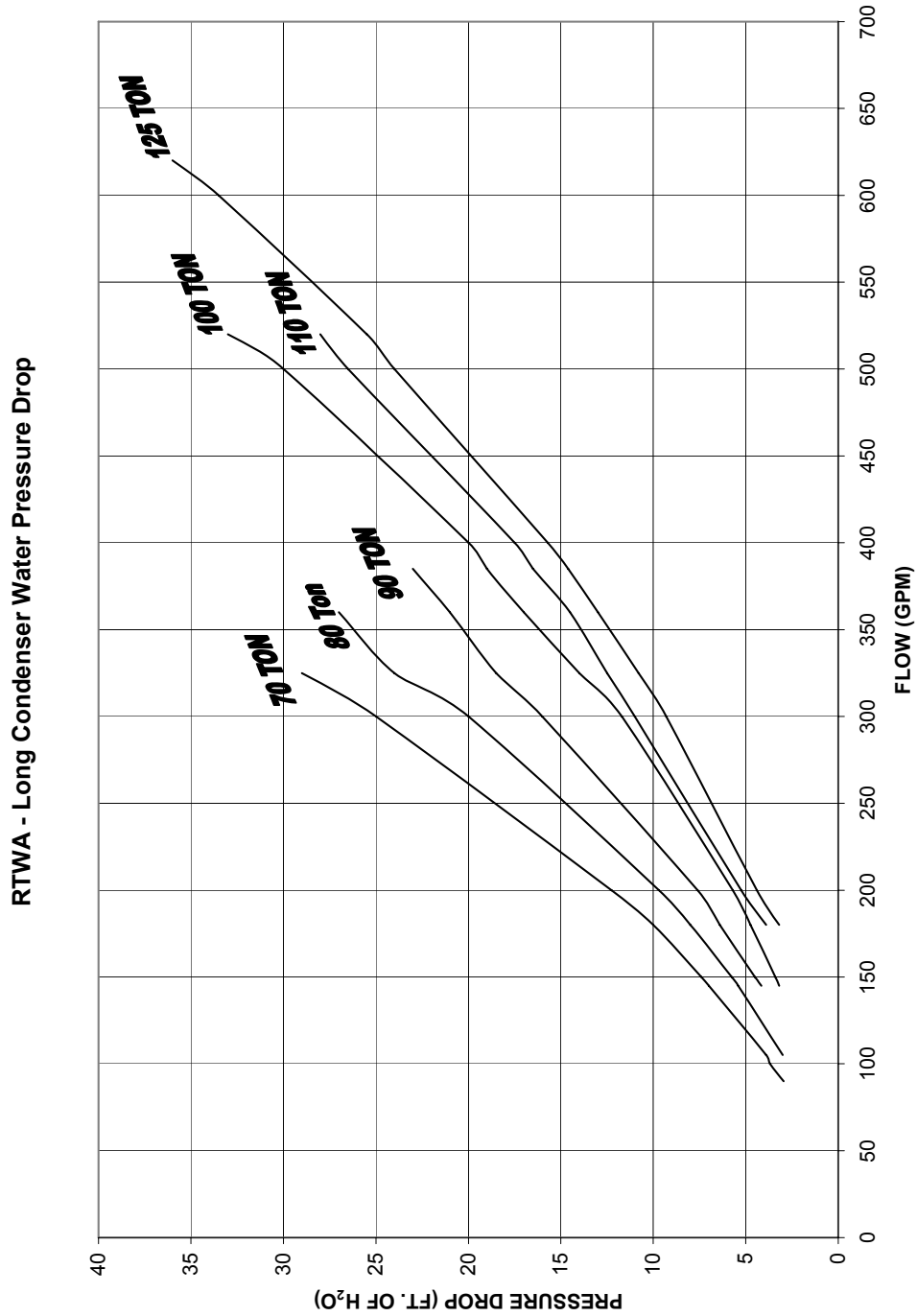

Figure 18 RTWA – Long Condenser Water Pressure Drop



Installation - Mechanical

Condenser Water Piping (for RTWA Units Only)

Condenser water inlet and outlet types, sizes and locations are given in Figures 3 to Condenser pressure drops are shown in Figures 17 and 18.

Condenser Piping Components

Condenser piping components and layout vary, depending on the location of connections and the water source. Figure 19 illustrates typical piping components for a well water (or city water) condensing source. Typical components for a cooling tower condensing source are shown in Figure 20.

Condenser piping components generally function identically to those in the evaporator piping system, as described in "Evaporator Water Piping (for RTWA and RTUA Units Only)" on Page 31. In addition, cooling tower systems should include a manual or automatic bypass valve that can alter the water flow rate, to maintain condensing pressure. Well water (or city water) condensing systems should include a pressure reducing valve and a water regulating valve, as shown in Figure 19.

The pressure reducing valve should be installed to reduce water pressure entering the condenser. This is required only if the water pressure exceeds 150 psig. This is necessary to prevent damage to the disc and seat of the water regulating valve that can be caused by excessive pressure drop through the valve and also due to the design of the condenser. The condenser waterside is rated at 150 psi.

CAUTION

Equipment Damage!

To prevent damage to the condenser or regulating valve, the condenser water pressure should not exceed 150 psig.

The optional water regulating valve maintains condensing pressure and temperature by throttling water flow leaving the condenser in response to compressor discharge pressure. Adjust the regulating valve for proper operation during unit start-up.

This valve is not used in cooling tower applications. Cooling towers, however, may require the use of a three-way, pilot-operated regulating/bypass valve, to maintain balance between cooling tower water temperature and condensing pressure.

NOTE: Plugged tees are installed to provide access for chemical cleaning of the condenser tubes.

Condenser piping must be in accordance with all applicable local and national codes.

Condenser Drains

The condenser shells can be drained by removing the drain plugs from the bottom of the condenser heads. Also, remove the vent plugs at the top of the condenser heads to facilitate complete drainage.

When the unit is shipped, the drain plugs are removed from the condenser and placed in a plastic bag in the control panel, along with the evaporator drain plug. The condenser drains may be connected to suitable drains to permit drainage during unit servicing. If they are not, the drain plugs must be installed.

Installation - Mechanical

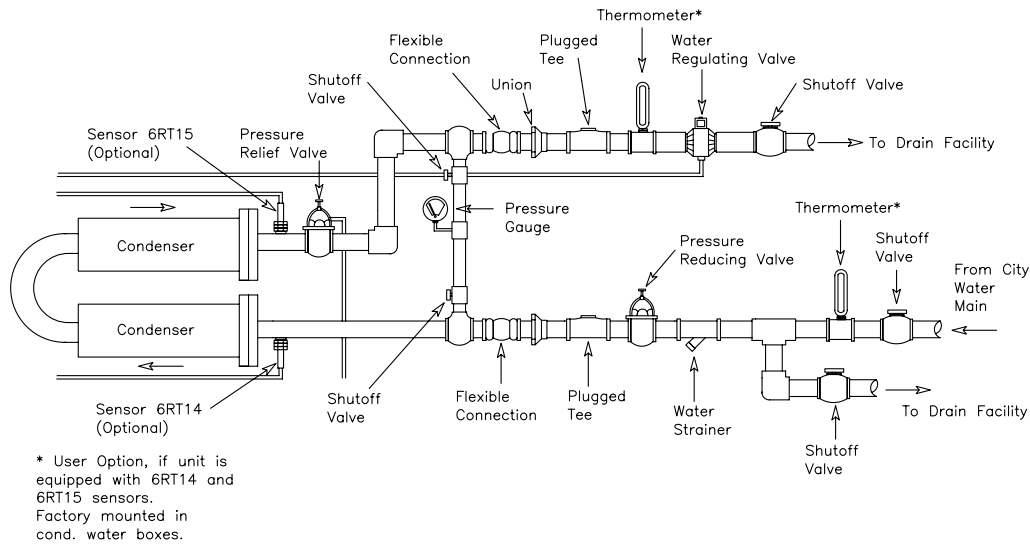

Figure 19 Typical Well (city) Water Piping Components for Condenser Water Circuit

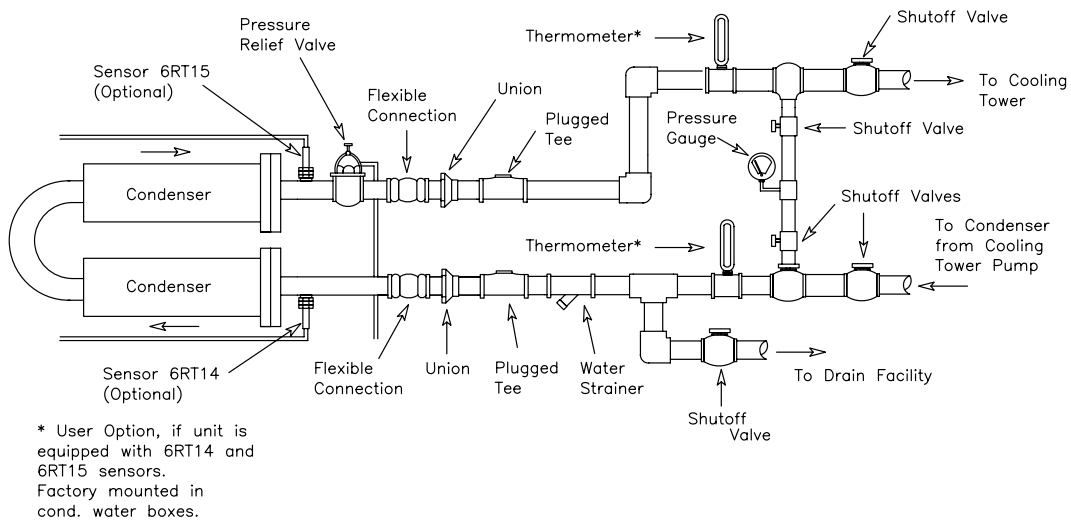

Figure 20 Typical Cooling Tower Water Piping Components for Condenser Water Circuit

Water Regulations Valve (for RTWA Units Only)

The water regulating valve maintains condensing pressure and temperature by throttling water flow leaving the condenser in response to compressor discharge pressure on the RTWA. Decrease the water flow as discharge pressure falls and increase the water flow when discharge pressure rises. This valve is not used in cooling tower applications. Cooling towers, however, may require the use of a three-way bypass valve to maintain balance between cooling tower water temperature and condensing pressure.

Installation - Mechanical

Typically, two regulating valves will be required in parallel, each one responding to the refrigerant pressure in its corresponding condenser. Install the valves on the condenser leaving water line. The valves should be located after the thermometer and before the shutoff valve. Refer to Figure 21. Run the capillary tubing from the valve to the discharge service valve and attach it to the non-stem end of the discharge valve access port.

CAUTION: Equipment Damage!

To prevent refrigerant loss, locate capillary tubing and secure it, to avoid damage due to friction or vibration.

Insure that the valves are closed to the access port before removing the flare cap.

⚠ WARNING Prevent Injury!

To prevent injury due to instantaneous release of high pressure gas and/or contact with refrigerant, be sure the discharge valve access port is closed off before removing the flare cap.

Loosen the flare caps slowly, to relieve residual pressure and connect the water regulating valve capillary tubes. Adjust the regulating valves for proper operation during unit startup.

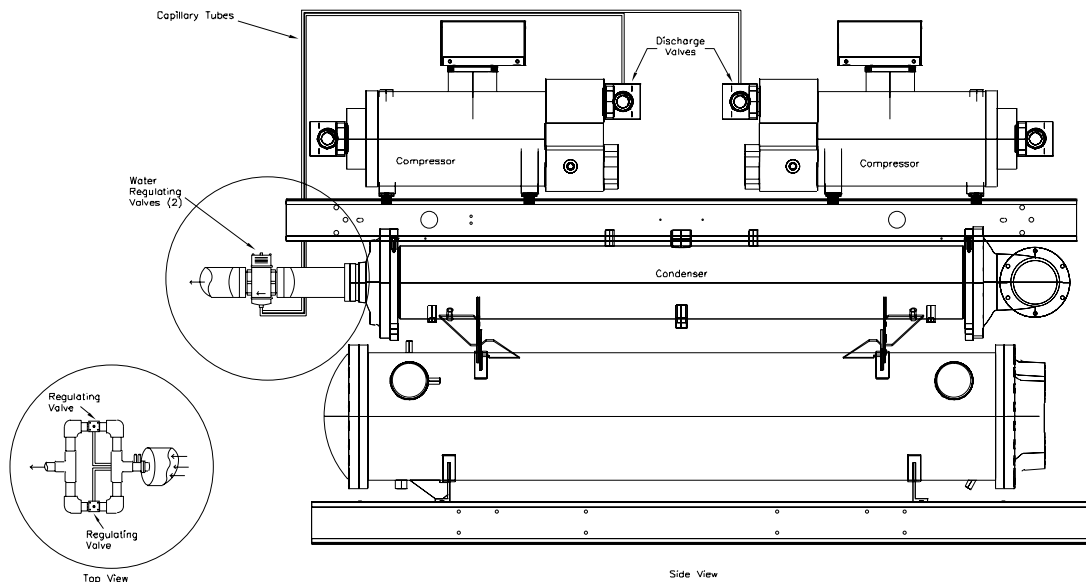

Figure 21 Typical Water Regulating Valve Installation Single-Circuit RTWA Unit



Installation - Mechanical

Water Treatment

Using untreated or improperly treated water in these units may result in inefficient operation and possible tube damage. Consult a qualified water treatment specialist to determine whether treatment is needed. The following disclamatory label is provided on each RTWA and RTUA unit:

CAUTION

Proper Water Treatment!

The use of untreated or improperly treated water in a Chiller may result in scaling, erosion, corrosion, algae or slime. It is recommended that the services of a qualified water treatment specialist be engaged to determine what water treatment, if any, is required. Trane assumes no responsibility for equipment failures which result from untreated or improperly treated water, or saline or brackish water.

Water Pressure Gauges

Install field-supplied pressure gauges (with manifolds, whenever practical) on the RTWA and RTUA units, as shown in Figures 15, 19 and 20. Locate pressure gauges or taps in a straight run of pipe; avoid placement near elbows, etc. Be sure to install the gauges at the same elevation.

To read manifolded pressure gauges, open one valve and close the other (depending upon the reading desired). This eliminates errors resulting from differently calibrated gauges installed at unmatched elevations.

Water Pressure Relief Valves

Install a water pressure relief valve in the condenser and evaporator leaving chilled water piping. See Figures 15, 19 and 20. Water vessels with close coupled shutoff valves have a high potential for hydrostatic pressure buildup on a water temperature increase. Refer to applicable codes for relief valve installation guidelines.

CAUTION

Prevent Shell Damage!

To prevent shell damage, install pressure relief valves in both the evaporator and condenser water systems.

Field-Installed Water Temperature Sensors

Entering and leaving evaporator water temperature sensors (6RT7, 6RT8) are factory installed on all units, excluding the RTCA. Entering and leaving condenser water temperature sensors are factory installed in the condenser water boxes, if the "Condenser Water Temperature Sensor Kit" is ordered with the unit (RTWA only).

Water Sensor Installation Procedure

If field installation is required, the sensors must be properly located to read a mixed water temperature. An installed sensor and fitting is illustrated in Figure 22.

1. Cut a properly-sized hole in the piping and weld a 1/4" NPT 150 psig half-coupling (field-provided) into the piping at each sensor location.
2. Using teflon tape, install the entire sensor compression fitting into the

Installation - Mechanical

coupling and tighten securely by turning the hex nut, on the fitting body only.

CAUTION Equipment Damage!

Do not tighten the clamping nut at this time. This will prevent proper sensor insertion.

3. Insert the sensor into the compression fitting (through the clamping nut) until the plastic coating on the sensor contacts the top of the clamping nut.
4. Use a wrench to carefully tighten the clamping nut until the sensor can no longer be turned by hand.
5. Scribe a reference line on the clamping nut at the "six o'clock" position. Then, while observing the reference point, tighten the nut 1-1/4 additional turns.

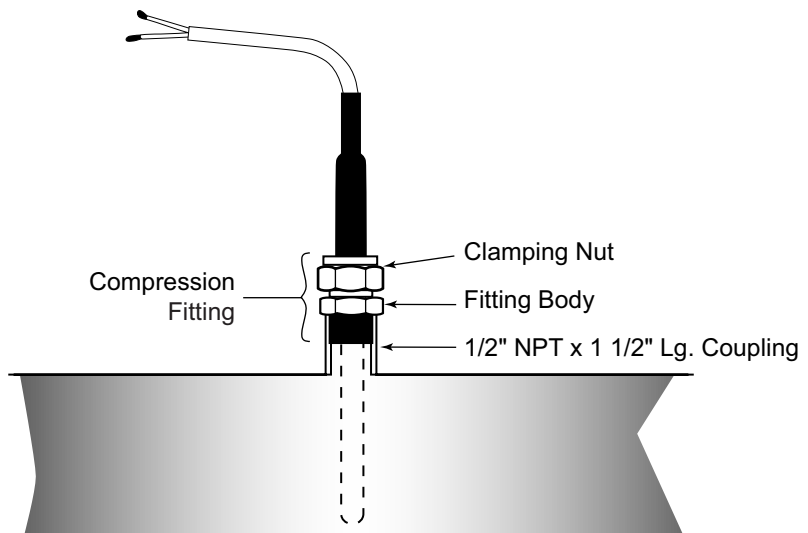

Figure 22 Water Temperature Sensor Installation

Refrigerant Relief Valve Venting

Condenser Pressure Relief Valve Venting (for RTWA units only)

All RTWA units utilize a refrigerant-pressure relief valve for each circuit which must be vented to the outdoor atmosphere. The valves are located at the top of the condenser. When facing the control panel, Circuit #1 relief valve is approximately 5" left of center and Circuit #2 relief valve is approximately 5" right of center. Relief valve connections are 5/8" flare. See Figure 21 and Table 5. Refer to local codes for relief valve vent line sizing requirements.

NOTE: Vent line length must not exceed code recommendations. If the line length will exceed code recommendations for the outlet size of the valve, install a vent line of the next larger pipe size.

Installation - Mechanical

CAUTION

Equipment Damage!

To prevent capacity reduction and relief valve damage, do not exceed vent piping code specifications.

Relief valve discharge setpoints are 450 psig. Once the relief valve has opened, it will reclose when pressure is reduced to a safe level.

Pipe each relief valve on the unit into a common vent line. Provide access valve located at the low point of the vent piping, to enable draining of any condensate that may accumulate in the piping.

⚠ WARNING

Contains Refrigerant!

System contains oil and refrigerant under high pressure. Recover refrigerant to relieve pressure before opening the system. See unit nameplate for refrigerant type. Do not use non-approved refrigerants, refrigerant substitutes, or refrigerant additives.

Failure to follow proper procedures or the use of non-approved refrigerants, refrigerant substitutes, or refrigerant additives could result in death or serious injury or equipment damage.

If multiple chillers are installed, each unit must have a separate venting for its relief valves. Consult local regulations for any special relief line requirements.

Table 5 Relief Valve Descriptions

Relief Setpoint	450 psig	300 psig
Units	RTWA/RTUA	RTWA/RTUA
Quantity	1 per ckt	1 per ckt
Relief Rate		
Superior	N/A	10.21 lba/min
Henry	35.8lba/min	N/A

Evaporator Pressure Relief Valve Venting (for RTWA and RTUA units only)

All RTWA and RTUA units utilize a low-side refrigerant-pressure relief valve for each circuit which must be vented to the outdoor atmosphere. The valves are located on the refrigerant head of the evaporator, one per circuit. Relief valve connections are 3/8" flare. Refer to Figure 21 and Table 5. Refer to local codes for relief valve vent line sizing requirements.

NOTE: Vent line length must not exceed code recommendations. If the line length will exceed code recommendations for the outlet size of the valve, install a vent line of the next larger pipe size.



Installation - Mechanical

CAUTION

Equipment Damage!

To prevent capacity reduction and relief valve damage, do not exceed vent piping code specifications.

Relief valve discharge setpoints are 300 psig. Once the relief valve has opened, it will reclose when pressure is reduced to a safe level.

Pipe each relief valve on the unit into a common vent line. Provide an access valve located at the low point of the vent piping, to enable draining of any condensate that may accumulate in the piping.

⚠ WARNING

Contains Refrigerant!

System contains oil and refrigerant under high pressure. Recover refrigerant to relieve pressure before opening the system. See unit nameplate for refrigerant type. Do not use non-approved refrigerants, refrigerant substitutes, or refrigerant additives.

Failure to follow proper procedures or the use of non-approved refrigerants, refrigerant substitutes, or refrigerant additives could result in death or serious injury or equipment damage.

If multiple chillers are installed, each unit must have a separate venting for its relief valves. Consult local regulations for any special relief line requirements.

Initial Leak Test

The RTWA units are shipped with a full charge of refrigerant and oil. Before operating the unit, install appropriate gauges to verify that the charges are intact. If there is no pressure, leak test the unit and make the appropriate repairs.

The RTUA units are shipped with a nitrogen holding charge and a full charge of oil, excluding the additional charge needed for field piping. Before installing these units, verify that the holding charge was not lost. Install the appropriate pressure gauges and measure the pressure. If there is no pressure, leak test the unit and repair all leaks before installing the interconnecting refrigerant piping.

The RTCA units are shipped only with a nitrogen holding charge. Prior to installation, confirm that the charge was not lost. If there is no pressure on the condensing unit, leak test the unit and make necessary repairs. Then continue with the refrigerant piping.

Installation - Remote Condenser

Remote Air-Cooled Condenser Interconnecting Refrigerant Piping

The RTUA compressor chiller is shipped with a full charge of oil, excluding the additional charge for the field piping, and a nitrogen holding charge. The RTCA unit is an air-cooled condenser that is designed for use with the RTUA unit. The RTUA unit is designed to be most effective when used with the RTCA air-cooled condenser. Other air-cooled condensers can be used in place of the RTCA condenser, but the overall performance of the system may be different from that published in the catalogs. The following section covers the required piping between the RTUA unit and the appropriate air-cooled condenser.

The RTUA unit consists of an evaporator, two helical rotor compressors (one per circuit), oil coolers, liquid line service valves, sightglasses, electronic expansion valves and filter driers. The discharge line leaving the oil separator is capped and brazed and the liquid line is terminated with a liquid line service valve. The installing contractor need only provide the interconnecting piping between the RTUA and the air-cooled condenser.

Refrigerant piping must be properly sized and applied, since these factors have a significant effect on system performance and reliability.

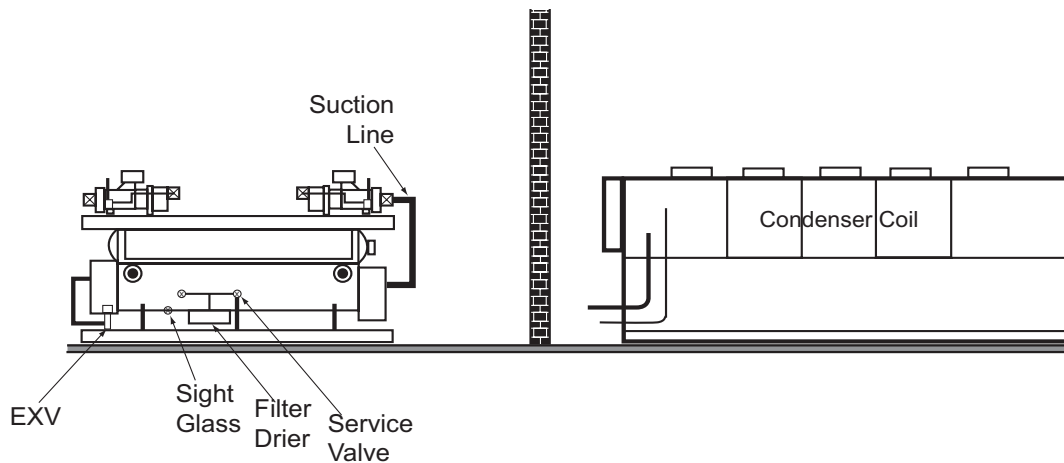

RESTRICTIONS:

- Total distance between components should not exceed 200 feet (actual) or 300 feet (actual) or 300 feet (equivalent).
- Liquid line height must not exceed 15 ft. from the base of the air cooled condenser unit.
- Discharge line trap is recommended leaving the oil separator if the discharge piping runs for more than 10 (actual) feet horizontally above the RTUA unit.

Figure 23 No Elevation Difference

Installation - Remote Condenser

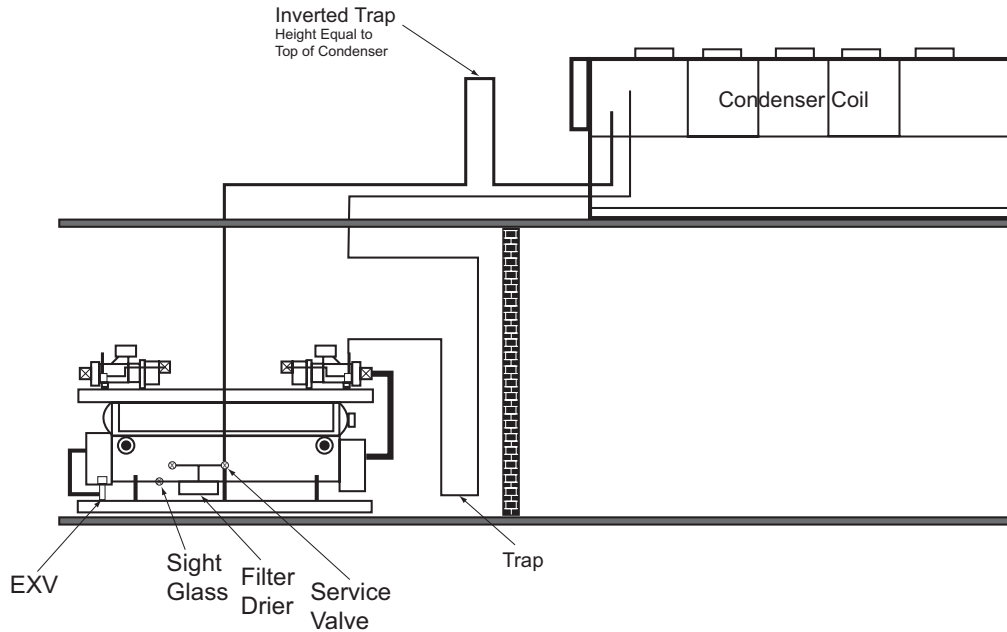

RESTRICTIONS:

- Total distance between components should not exceed 200 ft. (actual) or 300 ft. (equivalent).
- Elevation difference greater than 100 ft. (actual) will result in at least a 2% efficiency decrease.

Figure 24 Condenser Above the Compressor /Chiller

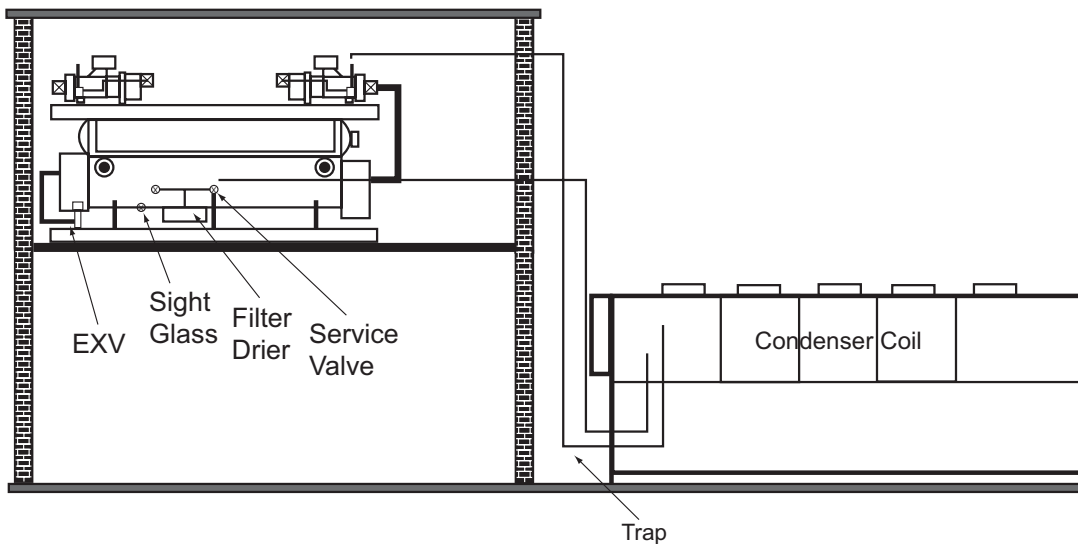

RESTRICTIONS:

- Total distance between components should not exceed 200 ft. (actual) or 300 ft. (equivalent).
- Liquid line riser(s) must not exceed 15 ft. from base of air cooled condenser.

Figure 25 Condenser Below Compressor/ Chiller



Installation - Remote Condenser

For best reliability and performance, the RTUA should be matched with the Trane RTCA. If a non-RTCA condenser is used, the overall performance and reliability of the RTUA may be affected. Depending on the customer's fan control, nuisance trips may occur on the RTUA unit, due to head pressure instability.

If a non-RTCA condenser is supplied, it must be capable of providing a minimum of 5 F subcooling at the EXV. The RTUA requires subcooled liquid at the expansion valves. Without a minimum of 5 F subcooling, the RTUA will not operate as designed.

Piping should be sized and laid out according to the job plans and specifications. This design should be completed during system component selection.

NOTE: Use Type L refrigerant-grade copper tubing only.

The refrigerant lines must be isolated to prevent line vibration from being transferred to the building. Do not secure the lines rigidly to the building at any point.

All horizontal suction lines should be pitched downward, in the direction of flow, at a slope of 1/2 in. per 10 feet of run. This allows for larger line size, which will improve unit efficiency.

Important: Relieve nitrogen pressure before removing end caps.

Do not use a saw to remove end caps, as this may allow copper chips to contaminate the system. Use a tubing cutter or heat to remove the end caps.

⚠ WARNING

Prevent Injury!

When sweating line connections, always provide a sufficient purge of dry nitrogen through the tubing to prevent the formation of oxides/scaling cause by high temperature from brazing. Use a pressure regulator in the line between the unit and the high pressure nitrogen cylinder to avoid over pressurization and possible explosion. If any refrigerant or refrigerant vapors are present a thorough purge with dry nitrogen will prevent the possible formation of toxic phosgene gas. Failure to follow these recommendations could result in death or serious injury.

System Configuration

The system can be configured in any of the primary arrangements as shown in [Figures 23, 24 and 25](#). The configuration and its associated elevation, along with the total distance between the RTUA and the air-cooled condenser, plays a critical role in determining the liquid line and discharge line sizes. This will also affect the field refrigerant and oil charges. Consequently, there are physical limits which must not be violated if the system is to operate as designed. Please note the following restrictions:

1. The discharge line sizing is different for different leaving evaporator water temperatures.



Installation - Remote Condenser

CAUTION Catastrophic Damage!

Tables 8, 9 and 10 show line sizing for leaving evaporator water temperatures ranging from 0 F to 60 F. Only units with a “2” or “4” in the 12th digit of the model number of the RTUA unit can be piped using Tables 8 and Unless the RTUA unit is designed for low temperature applications, Table 8 must be used. Catastrophic damage may result if the incorrect table is used for pipe sizing.

2. The total distance between the RTUA and the aircooled condenser must not exceed 200 actual feet or 300 equivalent feet.
3. Liquid line risers must not exceed 15 feet from the base of the air-cooled condenser.
4. Discharge line risers cannot exceed an elevation difference greater than 100 actual feet without a minimum of 2% efficiency decrease.
5. Refer to [Figures 23, 24 and 25](#) for location of recommended traps.
6. Circuit #1 on the condenser must be connected to Circuit # 1 on the RTUA unit.

CAUTION Equipment Damage!

If circuits are crossed, serious equipment damage may occur.

NOTE: The piping shown in [Figures 23, 24 and 25](#) are for one circuit only. The piping for the other circuit should follow the same guidelines.

Equivalent Line Length

To determine the appropriate size for field installed liquid and discharge lines, it is first necessary to establish the equivalent length of pipe for each line, including the added flow resistance of elbows, valves, etc. An initial approximation can be made by assuming that the equivalent length of pipe is 1.5 times the actual pipe length.

Table 6 RTUA Circuit Capacities

MODEL	CIRCUIT 1	CIRCUIT 2
70	35	35
80	40	40
90	50	40
100	50	50
110	60	50
125	60	60

It is also necessary to know the capacity (tons) for each circuit. Circuit capacities for each RTUA unit are listed in [Table 6](#).



Installation - Remote Condenser

NOTE: Table 7 states the equivalent length, in feet, for various non-ferrous valves and fittings. When calculating the equivalent length, do not include piping of the unit. Only field piping must be considered.

Table 7 Equivalent Lengths of Non-ferrous Valves and Fittings

LINE SIZE Inches OD	GLOBE Valve (Ft)	ANGLE Valve (Ft)	SHORT Radius Elbow (Ft)	LONG Radius Elbow (Ft)
1 1/8	87	29	2.7	1.9
1 3/8	102	33	3.2	2.2
1 5/8	115	34	3.8	2.6
2 1/8	141	39	5.2	3.4
2 5/8	159	44	6.5	4.2
3 1/8	185	53	8	5.1
3 5/8	216	66	10	6.3
4 1/8	248	76	12	7.3

Reproduced by permission of the Air Conditioning and Refrigeration Institute.

Liquid Line Sizing

The Trane Company recommends that the liquid line diameter be as small as possible, while maintaining acceptable pressure drop. This is necessary to minimize refrigerant charge. The total length between the components must not exceed 200 actual feet or 300 equivalent feet. Refer to [Table 11](#) for the maximum allowable liquid line drainable to the evaporator, listed in actual feet, for applications with the condenser above the unit.

Liquid risers in the system will require an additional 0.5 psig pressure drop per foot of vertical rise. The liquid line risers must not exceed 15 feet from the base of the air-cooled condenser. The liquid line does not have to be pitched. Liquid line sizing for these units are shown in [Tables 7 to 9](#).

Liquid lines are not typically insulated. However, if the lines run through an area of high ambient temperature (eg. boiler room), subcooling may drop below required levels. In these situations, insulate the liquid lines.

NOTE: In case of power failure to the expansion valve, the amount of liquid refrigerant contained in the liquid line above the evaporator must not exceed the holding capacity of the evaporator. Therefore, the actual length of the drainable liquid in the liquid line is restricted to the above values.



Installation - Remote Condenser

Table 8 Liquid Line Sizes (O.D.) For Units with Leaving Evaporator Water Temp of 40-60 F with Daytime 40-60 F and Ice Making

35 Ton Circuit (40 - 60F LWT)				
Total Equiv. Length (ft.)	Liquid Line Size (OD")			
	Horizontal or Downflow	Upflow 1-5 ft.	Upflow 6-10 ft.	Upflow 11-15 ft.
25	1 1/8	1 1/8	1 1/8	1 1/8
50	1 1/8	1 1/8	1 1/8	1 1/8
75	1 1/8	1 1/8	1 1/8	1 3/8
100	1 1/8	1 1/8	1 1/8	1 3/8
125	1 1/8	1 1/8	1 1/8	1 3/8
150	1 1/8	1 1/8	1 1/8	1 3/8
175	1 1/8	1 1/8	1 3/8	1 3/8
200	1 1/8	1 1/8	1 3/8	1 3/8
225	1 1/8	1 1/8	1 3/8	1 5/8
250	1 1/8	1 3/8	1 3/8	1 5/8
275	1 1/8	1 3/8	1 3/8	1 5/8
300	1 3/8	1 3/8	1 3/8	1 5/8

40 Ton Circuit (40 - 60F LWT)				
Total Equiv. Length (ft.)	Liquid Line Size (OD")			
	Horizontal or Downflow	Upflow 1-5 ft.	Upflow 6-10 ft.	Upflow 11-15 ft.
25	1 1/8	1 1/8	1 1/8	1 1/8
50	1 1/8	1 1/8	1 1/8	1 3/8
75	1 1/8	1 1/8	1 1/8	1 3/8
100	1 1/8	1 1/8	1 1/8	1 3/8
125	1 1/8	1 1/8	1 3/8	1 3/8
150	1 1/8	1 1/8	1 3/8	1 3/8
175	1 1/8	1 3/8	1 3/8	1 5/8
200	1 1/8	1 3/8	1 3/8	1 5/8
225	1 3/8	1 3/8	1 3/8	1 5/8
250	1 3/8	1 3/8	1 3/8	1 5/8
275	1 3/8	1 3/8	1 3/8	1 5/8
300	1 3/8	1 3/8	1 3/8	1 5/8

50 Ton Circuit (40 - 60F LWT)				
Total Equiv. Length (ft.)	Liquid Line Size (OD")			
	Horizontal or Downflow	Upflow 1-5 ft.	Upflow 6-10 ft.	Upflow 11-15 ft.
25	1 1/8	1 1/8	1 1/8	1 1/8
50	1 1/8	1 1/8	1 1/8	1 3/8
75	1 1/8	1 1/8	1 3/8	1 3/8
100	1 1/8	1 1/8	1 3/8	1 3/8
125	1 1/8	1 3/8	1 3/8	1 5/8
150	1 1/8	1 3/8	1 3/8	1 5/8
175	1 3/8	1 3/8	1 3/8	1 5/8
200	1 3/8	1 3/8	1 3/8	1 5/8
225	1 3/8	1 3/8	1 5/8	1 5/8
250	1 3/8	1 3/8	1 5/8	2 1/8
275	1 3/8	1 3/8	1 5/8	2 1/8
300	1 3/8	1 3/8	1 5/8	2 1/8

60 Ton Circuit (40 - 60F LWT)				
Total Equiv. Length (ft.)	Liquid Line Size (OD")			
	Horizontal or Downflow	Upflow 1-5 ft.	Upflow 6-10 ft.	Upflow 11-15 ft.
25	1 1/8	1 1/8	1 1/8	1 3/8
50	1 1/8	1 1/8	1 3/8	1 3/8
75	1 1/8	1 1/8	1 3/8	1 5/8
100	1 1/8	1 3/8	1 3/8	1 5/8
125	1 3/8	1 3/8	1 3/8	1 5/8
150	1 3/8	1 3/8	1 3/8	1 5/8
175	1 3/8	1 3/8	1 5/8	1 5/8
200	1 3/8	1 3/8	1 5/8	2 1/8
225	1 3/8	1 3/8	1 5/8	2 1/8
250	1 3/8	1 5/8	1 5/8	2 1/8
275	1 3/8	1 5/8	1 5/8	2 1/8
300	1 3/8	1 5/8	1 5/8	2 1/8



Installation - Remote Condenser

Table 9 Liquid Line Sizes (O.D.)
For Units with Leaving Evaporator Water Temp of 20-39 F

35 Ton Circuit (20 - 39F LWT)				
Total Equiv. Length (ft.)	Liquid Line Size (OD")			
	Horizontal or Downflow	Upflow 1-5 ft.	Upflow 6-10 ft.	Upflow 11-15 ft.
25	7/8	7/8	7/8	1 1/8
50	7/8	7/8	7/8	1 1/8
75	7/8	7/8	1 1/8	1 1/8
100	7/8	1 1/8	1 1/8	1 3/8
125	1 1/8	1 1/8	1 1/8	1 3/8
150	1 1/8	1 1/8	1 1/8	1 3/8
175	1 1/8	1 1/8	1 3/8	1 3/8
200	1 1/8	1 1/8	1 3/8	1 3/8
225	1 1/8	1 1/8	1 3/8	1 3/8
250	1 1/8	1 1/8	1 3/8	1 3/8
275	1 1/8	1 1/8	1 3/8	1 5/8
300	1 1/8	1 1/8	1 3/8	1 5/8

40 Ton Circuit (20 - 39FLWT)				
Total Equiv. Length (ft.)	Liquid Line Size (OD")			
	Horizontal or Downflow	Upflow 1-5 ft.	Upflow 6-10 ft.	Upflow 11-15 ft.
25	7/8	7/8	7/8	1 1/8
50	7/8	7/8	1 1/8	1 1/8
75	7/8	1 1/8	1 1/8	1 3/8
100	1 1/8	1 1/8	1 3/8	1 3/8
125	1 1/8	1 1/8	1 3/8	1 3/8
150	1 1/8	1 1/8	1 3/8	1 3/8
175	1 1/8	1 1/8	1 3/8	1 3/8
200	1 1/8	1 1/8	1 3/8	1 5/8
225	1 1/8	1 3/8	1 3/8	1 5/8
250	1 1/8	1 3/8	1 3/8	1 5/8
275	1 1/8	1 3/8	1 3/8	1 5/8
300	1 1/8	1 3/8	1 3/8	1 5/8

50 Ton Circuit (20 - 39F LWT)				
Total Equiv. Length (ft.)	Liquid Line Size (OD")			
	Horizontal or Downflow	Upflow 1-5 ft.	Upflow 6-10 ft.	Upflow 11-15 ft.
25	7/8	7/8	1 1/8	1 1/8
50	7/8	1 1/8	1 1/8	1 3/8
75	1 1/8	1 1/8	1 1/8	1 3/8
100	1 1/8	1 1/8	1 1/8	1 3/8
125	1 1/8	1 1/8	1 3/8	1 3/8
150	1 1/8	1 1/8	1 3/8	1 5/8
175	1 1/8	1 3/8	1 3/8	1 5/8
200	1 1/8	1 3/8	1 3/8	1 5/8
225	1 3/8	1 3/8	1 3/8	1 5/8
250	1 3/8	1 3/8	1 3/8	1 5/8
275	1 3/8	1 3/8	1 3/8	1 5/8
300	1 3/8	1 3/8	1 5/8	1 5/8

60 Ton Circuit (20 - 39F LWT)				
Total Equiv. Length (ft.)	Liquid Line Size (OD")			
	Horizontal or Downflow	Upflow 1-5 ft.	Upflow 6-10 ft.	Upflow 11-15 ft.
25	1 1/8	1 1/8	1 1/8	1 1/8
50	1 1/8	1 1/8	1 1/8	1 3/8
75	1 1/8	1 1/8	1 1/8	1 3/8
100	1 1/8	1 1/8	1 3/8	1 3/8
125	1 1/8	1 3/8	1 3/8	1 5/8
150	1 1/8	1 3/8	1 3/8	1 5/8
175	1 3/8	1 3/8	1 3/8	1 5/8
200	1 3/8	1 3/8	1 3/8	1 5/8
225	1 3/8	1 3/8	1 3/8	1 5/8
250	1 3/8	1 3/8	1 5/8	1 5/8
275	1 3/8	1 3/8	1 5/8	2 1/8
300	1 3/8	1 3/8	1 5/8	2 1/8

Table 8 only applies to units that are designed for evaporator leaving water temperatures between 20 - 39 F. A 2 or 4 must appear in the 12th digit of the RTUA unit model number and the unit must be designed to operate between 20 - 39 F before this table can be used. If this table is used to size piping for standard units, catastrophic damage to the unit may occur.



Installation - Remote Condenser

Table 10 Liquid Line Sizes (O.D.)
For Units with Leaving Evaporator Water Temp of 0 - 19 F

35 Ton Circuit (0 - 19 F LWT)				
Total Equiv. Length (ft.)	Liquid Line Size (OD")			
	Horizontal or Downflow	Upflow 1-5 ft.	Upflow 6-10 ft.	Upflow 11-15 ft.
25	7/8	7/8	7/8	7/8
50	7/8	7/8	7/8	7/8
75	7/8	7/8	7/8	1 1/8
100	7/8	7/8	7/8	1 1/8
125	7/8	7/8	1 1/8	1 1/8
150	7/8	7/8	1 1/8	1 1/8
175	7/8	7/8	1 1/8	1 1/8
200	7/8	1 1/8	1 1/8	1 1/8
225	7/8	1 1/8	1 1/8	1 3/8
250	7/8	1 1/8	1 1/8	1 3/8
275	1 1/8	1 1/8	1 1/8	1 3/8
300	1 1/8	1 1/8	1 1/8	1 3/8

40 Ton Circuit (0 - 19 F LWT)				
Total Equiv. Length (ft.)	Liquid Line Size (OD")			
	Horizontal or Downflow	Upflow 1-5 ft.	Upflow 6-10 ft.	Upflow 11-15 ft.
25	7/8	7/8	7/8	7/8
50	7/8	7/8	7/8	1 1/8
75	7/8	7/8	7/8	1 1/8
100	7/8	7/8	1 1/8	1 1/8
125	7/8	7/8	1 1/8	1 1/8
150	7/8	1 1/8	1 1/8	1 1/8
175	7/8	1 1/8	1 1/8	1 3/8
200	1 1/8	1 1/8	1 1/8	1 3/8
225	1 1/8	1 1/8	1 1/8	1 3/8
250	1 1/8	1 1/8	1 1/8	1 3/8
275	1 1/8	1 1/8	1 1/8	1 3/8
300	1 1/8	1 1/8	1 1/8	1 3/8

50 Ton Circuit (0 - 19 F LWT)				
Total Equiv. Length (ft.)	Liquid Line Size (OD")			
	Horizontal or Downflow	Upflow 1-5 ft.	Upflow 6-10 ft.	Upflow 11-15 ft.
25	7/8	7/8	7/8	7/8
50	7/8	7/8	7/8	1 1/8
75	7/8	7/8	1 1/8	1 1/8
100	7/8	1 1/8	1 1/8	1 1/8
125	7/8	1 1/8	1 1/8	1 3/8
150	1 1/8	1 1/8	1 1/8	1 3/8
175	1 1/8	1 1/8	1 1/8	1 3/8
200	1 1/8	1 1/8	1 1/8	1 3/8
225	1 1/8	1 1/8	1 1/8	1 3/8
250	1 1/8	1 1/8	1 3/8	1 3/8
275	1 1/8	1 1/8	1 3/8	1 3/8
300	1 1/8	1 1/8	1 3/8	1 3/8

60 Ton Circuit (0 - 19 F LWT)				
Total Equiv. Length (ft.)	Liquid Line Size (OD")			
	Horizontal or Downflow	Upflow 1-5 ft.	Upflow 6-10 ft.	Upflow 11-15 ft.
25	7/8	7/8	7/8	1 1/8
50	7/8	7/8	1 1/8	1 1/8
75	7/8	1 1/8	1 1/8	1 1/8
100	1 1/8	1 1/8	1 1/8	1 3/8
125	1 1/8	1 1/8	1 1/8	1 3/8
150	1 1/8	1 1/8	1 1/8	1 3/8
175	1 1/8	1 1/8	1 3/8	1 3/8
200	1 1/8	1 1/8	1 3/8	1 3/8
225	1 1/8	1 1/8	1 3/8	1 3/8
250	1 1/8	1 1/8	1 3/8	1 5/8
275	1 1/8	1 3/8	1 3/8	1 5/8
300	1 1/8	1 3/8	1 3/8	1 5/8

Table 9 only applies to units that are designed for evaporator leaving water temperatures between 0 - 19 F. A 2 or 4 must appear in the 12th digit of the RTUA unit model number and the unit must be designed to operate below 19 F before this table can be used. If this table is used to size Dining for standard units, catastrophic damage to the unit may occur.



Installation - Remote Condenser

Table 11 Maximum Allowable Liquid Line Drainable to the Evaporator (Actual Ft.)

CIRCUIT SIZE Liquid Line Size (O.D.)	30 Ton	40 Ton	50 Ton	60 Ton
1 1/8	200	200	200	200
1 3/8	125	125	175	200

Table 12 Horizontal or Downflow Discharge Line Sizes (O.D.)

35 Ton Circuit				40 Ton Circuit			
Total Equiv. Length (ft.)	Leaving Evaporator Water Temperature (F)			Total Equiv. Length (ft.)	Leaving Evaporator Water Temperature (F)		
	40 - 60 F	20 - 39 F	0 - 19 F		40 - 60 F	20 - 39 F	0 - 19 F
25	2 1/8	1 5/8	1 5/8	25	2 1/8	1 5/8	1 5/8
50	2 1/8	1 5/8	1 5/8	50	2 1/8	1 5/8	1 5/8
75	2 1/8	1 5/8	1 5/8	75	2 1/8	1 5/8	1 5/8
100	2 1/8	1 5/8	1 5/8	100	2 1/8	1 5/8	1 5/8
125	2 1/8	1 5/8	1 5/8	125	2 1/8	1 5/8	1 5/8
150	2 1/8	1 5/8	1 5/8	150	2 1/8	1 5/8	1 5/8
175	2 1/8	1 5/8	1 5/8	175	2 1/8	1 5/8	1 5/8
200	2 1/8	1 5/8	1 5/8	200	2 1/8	1 5/8	1 5/8
225	2 1/8	2 1/8	1 5/8	225	2 1/8	2 1/8	1 5/8
250	2 1/8	2 1/8	1 5/8	250	2 1/8	2 1/8	1 5/8
275	2 1/8	2 1/8	1 5/8	275	2 1/8	2 1/8	1 5/8
300	2 1/8	2 1/8	1 5/8	300	2 1/8	2 1/8	1 5/8

50 Ton Circuit				60 Ton Circuit			
Total Equiv. Length (ft.)	Leaving Evaporator Water Temperature (F)			Total Equiv. Length (ft.)	Leaving Evaporator Water Temperature (F)		
	40 - 60 F	20 - 39 F	0 - 19 F		40 - 60 F	20 - 39 F	0 - 19 F
25	2 1/8	2 1/8	2 1/8	25	2 1/8	2 1/8	2 1/8
50	2 1/8	2 1/8	2 1/8	50	2 1/8	2 1/8	2 1/8
75	2 1/8	2 1/8	2 1/8	75	2 1/8	2 1/8	2 1/8
100	2 1/8	2 1/8	2 1/8	100	2 1/8	2 1/8	2 1/8
125	2 1/8	2 1/8	2 1/8	125	2 1/8	2 1/8	2 1/8
150	2 1/8	2 1/8	2 1/8	150	2 1/8	2 1/8	2 1/8
175	2 1/8	2 1/8	2 1/8	175	2 5/8	2 1/8	2 1/8
200	2 1/8	2 1/8	2 1/8	200	2 5/8	2 1/8	2 1/8
225	2 5/8	2 1/8	2 1/8	225	2 5/8	2 1/8	2 1/8
250	2 5/8	2 1/8	2 1/8	250	2 5/8	2 1/8	2 1/8
275	2 5/8	2 1/8	2 1/8	275	2 5/8	2 1/8	2 1/8
300	2 5/8	2 1/8	2 1/8	300	2 5/8	2 1/8	2 1/8



Installation - Remote Condenser

Table 13 Upflow Discharge Line Sizes (O.D.)

35 Ton Circuit				40 Ton Circuit			
Total Equiv. Length (ft.)	Leaving Evaporator Water Temperature (F)			Total Equiv. Length (ft.)	Leaving Evaporator Water Temperature (F)		
	40 - 60 F	20 - 39 F	0 - 19 F		40 - 60 F	20 - 39 F	0 - 19 F
0 - 300 ft.	2 1/8	1 5/8	1 5/8	0 - 300 ft.	2 1/8	1 5/8	1 5/8

50 Ton Circuit				60 Ton Circuit			
Total Equiv. Length (ft.)	Leaving Evaporator Water Temperature (F)			Total Equiv. Length (ft.)	Leaving Evaporator Water Temperature (F)		
	40 - 60 F	20 - 39 F	0 - 19 F		40 - 60 F	20 - 39 F	0 - 19 F
0 - 300 ft.	2 1/8	2 1/8	1 5/8	0 - 300 ft.	2 1/8	2 1/8	1 5/8

Discharge (Hot Gas) Line Sizing

The discharge lines should pitch downward, in the direction of the hot gas flow, at the rate of 1/2 inch per each 10 feet of horizontal run.

Discharge line size is based on the velocity needed to obtain sufficient oil return. Basic discharge line sizing is shown in [Tables 11](#) and [12](#), depending on the unit configuration.

NOTE: The proper column for leaving evaporator water temperature must be used to avoid catastrophic damage to the unit. Columns for 0 F to 19 F and 20 F to 39 F can only be used on units designed for low temperature applications. Refer to the design conditions of the unit to determine the correct column that must be used.

NOTE: The discharge line should drop well below the compressor discharge outlet before beginning its vertical rise. This prevents possible refrigerant drainage back to the compressor and oil separator during the unit STOP cycle. Refer to [Figures 23](#), [24](#) and [25](#) for details.

Refrigerant Sensors

If a Trane RTCA condenser is used with the RTUA unit, no sensors need to be field installed.

If a non-RTCA condenser is used, an outdoor ambient temperature sensor and a saturated condenser temperature sensor must be installed for the RTUA to control properly. The outdoor ambient temperature sensor must be installed in a location that accurately represents the outdoor ambient temperature which the condenser will encounter. It must not be exposed to direct sunlight or precipitation which could artificially alter the actual outdoor ambient temperature. Also, it must not be exposed to the recirculating air from the discharge of the condenser.

The saturated condensing temperature sensors must be installed on the refrigerant piping which leaves the condenser and enters the subcooler on both circuits. Strap the sensor into place, similar to the method used with most thermal expansion valve sensing bulbs. This sensor can be mounted externally if it is sufficiently insulated. The insulation covering the sensor must be capable of withstanding the higher temperatures without degradation. Failure to properly mount and insulate the saturated condensing refrigerant temperature sensor could cause poor control and/or possible compressor damage.



Installation - Remote Condenser

NOTE: Failure to properly mount and insulate the saturated condensing refrigerant temperature sensor could cause poor control and/or possible compressor damage.

If the sensor cannot be located at the point where the saturated gas enters the subcooler, locate the sensor closer to the subcooler rather than the condenser discharge gas. If saturated condensing temperature cannot be measured, it is preferred to measure liquid temperature rather than discharge temperature.

Refer to "Interconnecting Wiring" on Page 62 for interconnecting wiring of sensors for non-RTCA units.

NOTE: The RTUA unit ships with the outdoor ambient sensor and two saturated condenser temperature sensors in the control panel.

Refrigerant Charge Determination

The approximate amount of the refrigerant charge required by the system must be determined by referring to Table 14 and must be verified by running the system and checking the liquid line sightglasses.

Table 14 System Refrigerant Charge

Circuit Size	LBS of R-22
35	58
40	61
50	73
60	98

To determine the approximate charge, first refer to Table 13 and establish the required charge without the field-installed piping. Then refer to Table 14, to determine the charge required for the field-installed piping. The approximate charge is therefore the sum of the values from Tables 14 and 15.

Table 15 Field-Installed Piping Charge

PIPE O.D	DISCHARGE LINE (LBS.)	LIQUID LINE (LBS.)
7/8	---	24
1 1/8	---	41
1 3/8	4	62
1 5/8	6	88
2 1/8	10	153
2 5/8	15	236

Note:

The amounts of refrigerant listed in Table 15 are based on 100 feet of pipe. Actual requirements will be in direct proportion to the actual length of the piping.

Note:

Table 14 assumes:
Liquid temperature = 100 F
Saturated Discharge Temp. = 125 F
Discharge Superheat = 55 F



Installation - Remote Condenser

Oil Charge Determination

The RTUA unit is factory charged with the amount of oil required by the system, without the field-installed piping. The amount of additional oil required is dependent upon the amount of refrigerant that is added to the system for the field installed piping.

Calculate the amount of oil to be added, using the following formula:

$$\text{Pints of Oil (Trane OIL-31)} = \frac{\text{Lbs. of R-22 added}}{100} \times \text{for field-installed piping}$$

Example

Shown in Figure 26 are RTUA 80 ton and RTCA 80 ton units designed for a leaving evaporator water temperature of 42 degrees F. This example will show how to calculate the pipe sizes for both the liquid and discharge lines. The discharge line consists of one long radius elbow and 4 short radius elbows. The liquid line also consists of one long radius elbow and 4 short radius elbows.

Discharge Line

Actual length of horizontal or downflow lines	= 2 + 5 + 71 = 78 ft.
Actual length of upflow lines	= 15 1/2 + 5 = 20 1/2 ft.
Total equivalent length	= 1 1/2 x (78 + 20 1/2) = 147.75
Approx. line size for horizontal/downflow lines (Table 12)	= 2 1/8"
Approx. line size for upflow lines (Table 13)	= 2 1/8"
Equiv. length of one long radius elbow at 2 1/8" (Table 7)	= 3 2/5 ft.
Equiv. length of 4 short radius elbows at 2 1/8" (Table 7)	= 4 x 5 1/5 ft. = 20 4/5 ft.
Total equivalent length	= 78 + 20 1/2 + 3 2/5 + 20 4/5 = 122.7 ft.
New line size for horizontal/downflow and upflow lines remains (Table 12)	= 2 1/8"
ALL DISCHARGE LINE SIZES ARE	= 2 1/8"

Liquid Lines

Actual length of horizontal or downflow lines	= 8 + 75 + 20 = 103 ft.
Actual length of upflow lines	= 8 ft.
Total equivalent length	= 1 1/2 X (103 + 8) = 166 1/2 ft.
Approx. line size for horizontal/downflow lines (Table 8)	= 1 1/8"
Approx. line size for upflow lines (Table 8)	= 1 3/8 ft.
Equiv. length of one long radius elbow at 1 1/8" (Table 7)	= 1 9/10
Equiv. length of 4 short radius elbows at 1 1/8" (Table 7)	= 4 x 2 7/10 ft. = 10 4/5 ft.
Total equivalent length	= 103 + 8 + 19/10 + 10 2/5 = 123 7/10 ft.

Installation - Remote Condenser

New line size for horizontal and downflow lines
remains
(Table 8) = 1 1/8"

HORIZONTAL AND DOWNFLOW LIQUID
LINES ARE = 1 1/8"

UPFLOW LIQUID LINES ARE = 1 3/8"

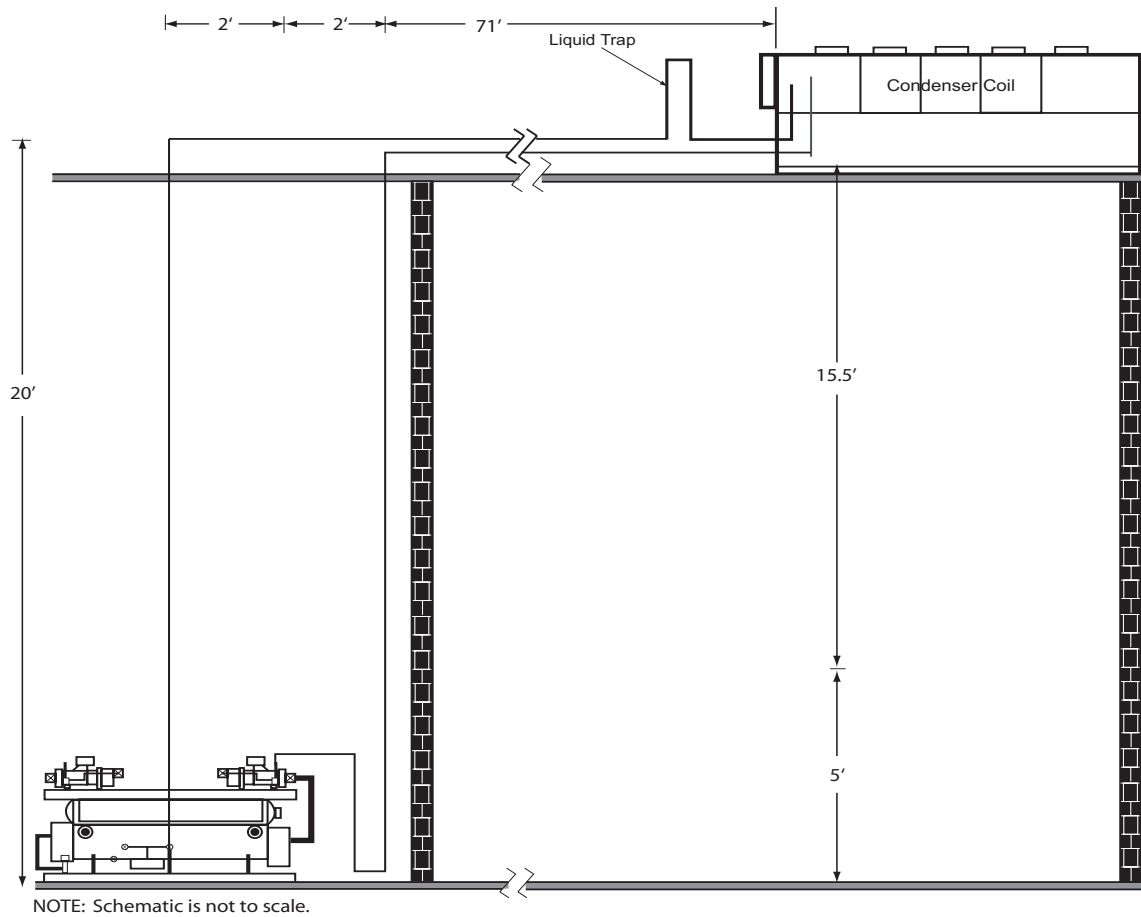

Figure 26 Example Pipe Size Configuration



Installation - Electrical

⚠ WARNING

Hazardous Voltage w/Capacitors!

Disconnect all electric power, including remote disconnects before servicing. Follow proper lockout/tagout procedures to ensure the power cannot be inadvertently energized. For variable frequency drives or other energy storing components provided by Trane or others, refer to the appropriate manufacturer's literature for allowable waiting periods for discharge of capacitors. Verify with an appropriate voltmeter that all capacitors have discharged. Failure to disconnect power and discharge capacitors before servicing could result in death or serious injury.

Note: For additional information regarding the safe discharge of capacitors, see PROD-SVB06A-EN or PROD-SVB06A-FR

All wiring must comply with local codes and the National Electric Code. Typical field wiring diagrams are shown in Section "Unit Wiring". Minimum circuit ampacities and other unit electrical data are on the unit nameplate and are shown in Table 16. See the unit order specifications for actual electrical data. Specific electrical schematics and connection diagrams are shipped with the unit.

CAUTION

Use Copper Conductors Only!

Unit terminals are not designed to accept other types of conductors. Failure to use copper conductors may result in equipment damage.

Do not allow conduit to interfere with other components, structural members or equipment.

Control voltage (115V) wiring in conduit must be separate from conduit carrying low voltage (<30V) wiring.



Installation - Electrical

Table 16 RTWA Electrical Data

Unit Wiring			Motor Data				
Unit Size	Rated Voltage (V/HZ/Phase)	MCA (1)	Max. Fuse or HACR (2)	Rec Time Delay or RDE (3)	Qty.	Compressor (Ea)	
						RLA (4)	LRA (6)
RTWA 70	200/60/3	237	300	300	2	105/105	800/800
Std. Cond. Temp	230/60/3	205	250	250	2	91/91	690/690
	460/60/3	104	125	125	2	46/46	330/330
	575/60/3	84	110	100	2	37/37	270/270
RTWA 80	200/60/3	279	400	350	2	124/124	880/880
Std. Cond. Temp	230/60/3	243	350	300	2	108/108	760/760
	460/60/3	122	175	150	2	54/54	380/380
	575/60/3	97	125	110	2	43/43	304/304
RTWA 90	200/60/3	329	450	400	2	164/124	990/880
Std. Cond. Temp	230/60/3	287	400	350	2	143/108	820/760
	460/60/3	144	200	175	2	72/54	410/380
	575/60/3	115	150	150	2	57/43	328/304
RTWA 100	200/60/3	369	500	450	2	164/164	990/990
Std. Cond. Temp	230/60/3	322	450	400	2	143/143	820/820
	460/60/3	162	225	200	2	72/72	410/410
	575/60/3	129	175	150	2	57/57	328/328
RTWA 110	200/60/3	407	600	500	2	194/164	1190/990
Std. Cond. Temp	230/60/3	355	500	400	2	169/143	1044/820
	460/60/3	179	250	200	2	85/77	522/410
	575/60/3	142	200	175	2	68/57	420/328
RTWA 125	200/60/3	437	600	300	2	194/194	1190/1190
Std. Cond. Temp	230/60/3	381	500	250	2	169/169	1044/1044
	460/60/3	192	250	125	2	85/85	522/522
	575/60/3	153	200	100	2	68/68	420/420

1. MCA-Minimum Circuit Ampacity - 125 percent of the largest compressor RLA plus 100 percent of the second compressor RLA.
2. HACR type circuit breaker for CSA only. Fuse size (HACR breaker) 225 percent of the largest compressor RLA plus 100 percent of the second compressor RLA.
3. Recommended Time Delay or Dual Element (RDE) Fuse Size - 150 percent of the largest compressor RLA plus 100 percent of the second compressor RLA.
4. Local codes may take precedence.
5. Voltage Utilization range:
6. RLA-Rated Load Amps - Rated in accordance with UL Standard 1995.
7. LRA-Locked Rotor Amps - Based on full winding starts.
8. Data containing information on two circuits shown as follows: ckt 1/ckt 2.



Installation - Electrical

Table 17 RTUA and RTWA High Temp Condenser Electrical Data

Unit Wiring			Motor Data				
Unit Size	Rated Voltage (V/Hz/Phase)	MCA (1)	Max. Fuse or HACR (2)	Rec Time Delay or RDE (3)	Qty.	Compressor (Ea)	
						RLA (4)	LRA (6)
RTUA 70	200/60/3	259	350	300	2	115/115	800/800
RTWA 70 High	230/60/3	225	300	250	2	100/100	690/690
Cond.	460/60/3	113	150	125	2	50/50	330/330
Temp	575/60/3	90	125	100	2	40/40	270/270
RTUA 80	200/60/3	320	450	400	2	142/142	880/880
RTWA 80 High	230/60/3	279	400	350	2	124/124	760/760
Cond.	460/60/3	140	200	175	2	62/62	380/380
Temp	575/60/3	113	150	125	2	50/50	304/304
RTUA 90	200/60/3	382	500	450	2	192/142	990/880
RTWA 90 High	230/60/3	333	450	400	2	167/124	820/760
Cond.	460/60/3	167	250	200	2	84/62	410/380
Temp	575/60/3	134	200	175	2	67/50	328/304
RTUA 100	200/60/3	432	600	500	2	192/192	990/990
RTWA 100 High	230/60/3	376	500	450	2	167/167	820/820
Cond.	460/60/3	189	250	225	2	84/84	410/410
Temp	575/60/3	151	200	175	2	67/67	328/328
RTUA 110	200/60/3	484	700	600	2	233/192	1190/990
RTWA 110 High	230/60/3	421	600	600	2	203/167	1044/820
Cond.	460/60/3	211	300	250	2	101/84	522/410
Temp	575/60/3	169	225	200	2	81/67	420/328
RTUA 125	200/60/3	525	700	600	2	233/233	1190/1190
RTWA 125 High	230/60/3	457	600	600	2	203/203	1044/820
Cond.	460/60/3	228	300	250	2	101/101	522/522
Temp	575/60/3	183	250	225	2	81/81	420/420

1. MCA-Minimum Circuit Ampacity - 125 percent of the largest compressor RLA plus 100 percent of the second compressor RLA.
2. HACR type circuit breaker for CSA only. Fuse size (HACR breaker) 225 percent of the largest compressor RLA plus 100 percent of the second compressor RLA.
3. Recommended Time Delay or Dual Element (RDE) Fuse Size - 150 percent of the largest compressor RLA plus 100 percent of the second compressor RLA.
4. Local codes may take precedence.
5. Voltage Utilization range:
6. RLA-Rated Load Amps - Rated in accordance with UL Standard 1995.
7. LRA-Locked Rotor Amps - Based on full winding starts.
8. Data containing information on two circuits shown as follows: ckt 1/ckt 2.



Installation - Electrical

Table 18 RTCA Electrical Data

Unit Size	Rotated Voltage (V/HZ/Phase)	Unit Wiring			Fan Motor Data			Control KW
		MCA (1)	Max. Fuse or HACR (2)	Rec Time Delay or RDE (3)	Qty.	KW	FLA)	
RTCA 70	200/60/3	39.6	40	40	8	1	4.8	0.75
	230/60/3	39.6	40	40	8	1	4.8	0.75
	460/60/3	20.6	25	25	8	1	2.5	0.75
	575/60/3	18.2	20	20	8	1	2.2	0.75
RTCA 80	200/60/3	39.6	40	40	8	1	4.8	0.75
	230/60/3	39.6	40	40	8	1	4.8	0.75
	460/60/3	20.6	25	25	8	1	2.5	0.75
	575/60/3	18.2	20	20	8	1	2.2	0.75
RTCA 90	200/60/3	44.4	45	45	9	1	4.8	0.75
	230/60/3	44.4	45	45	9	1	4.8	0.75
	460/60/3	23.1	25	25	9	1	2.5	0.75
	575/60/3	20.4	25	25	9	1	2.5	0.75
RTCA 100	200/60/3	49.2	50	50	10	1	4.8	0.75
	230/60/3	49.2	50	50	10	1	4.8	0.75
	460/60/3	25.6	30	30	10	1	2.5	0.75
	575/60/3	22.6	25	25	10	1	2.2	0.75
RTCA 110	200/60/3	49.2	50	50	10	1	4.8	0.75
	230/60/3	49.2	50	50	10	1	4.8	0.75
	460/60/3	25.6	30	30	10	1	2.5	0.75
	575/60/3	22.6	25	25	10	1	2.2	0.75
RTCA 125	200/60/3	49.2	50	50	10	1	4.8	0.75
	230/60/3	49.2	50	50	10	1	4.8	0.75
	460/60/3	25.6	30	30	10	1	2.5	0.75
	575/60/3	22.6	25	25	10	1	2.2	0.75

- (1) MCA - Minimum Circuit Am capacity - 125 percent of largest fan motor FLA plus 100 percent of the other fan motors FLAs.
- (2) HACR type circuit breaker for CSA only. Fuse size (HACR breaker) 225 percent of the largest fan motor FLA plus 100 percent of the other fan motor FLAs.
- (3) RECOMMENDED TIME DELAY OR DUAL ELEMENT (RDE) FUSE SIZE: 150 percent of the largest fan motor FLA plus 100 percent of the other fan motor FLAs.
- (4) RLA - Rated Load Amps - rated in accordance with UL Standard 1995.
- (5) Local codes may take precedence.
- (6) LRA - Locked Rotor Amps - based on full winding starts.
- (7) VOLTAGE UTILIZATION RANGE:
- (8) Data containing information on two circuits shown as follows: ckt 1/ckt 2



Installation - Electrical

Installer-Supplied Components

The installer must provide the following components if not ordered with the unit:

- Power supply wiring (in conduit) for all field-wired connections.
- All control (interconnecting) wiring (in conduit) for field supplied devices.
- Fused-disconnect switches.
- Power factor correction capacitors.

Power Supply Wiring

All power supply wiring must be sized and selected accordingly by the project engineer in accordance with National Electric Code.

All wiring must comply with local codes and the National Electrical Code. The installing (or electrical) contractor must provide and install the system interconnecting wiring, as well as the power supply wiring. It must be properly sized and equipped with the appropriate fused disconnect switches. The type and installation location(s) of the fused disconnects must comply with all applicable codes.

Cut holes for the appropriately-sized wiring conduits in the upper right side of the power connection panel on the RTWA and RTUA units. The wiring is passed through these conduits and connected to the terminal blocks or optional unit-mounted disconnect. Refer to Figures 3 thru 6 and Figures 8 and 9.

For the RTCA units, refer to Figure 11 for the power supply wiring hole location.

Control Power Supply

The RTWA and RTUA units are equipped with a control power transformer. It is not necessary to provide control power voltage to these units.

Water Pump Power Supply

Provide power supply wiring with fused-disconnect for the chilled water pump(s) (RTWA and RTUA) and condenser water pump(s) (RTWA only).

Interconnecting Wiring

Chilled Water Pump

CAUTION Equipment Damage!

The chiller water pump must operate for a minimum of one minute after the UCM receives a command through the external Auto/Stop input to shut down the chilled water system. Do not use the proof of chiller water flow interlock (1U1 TB3-1 and -2) by itself as the normal means of terminating chiller operation. Failure to continue pump operation for one minute after unit shut down may result in evaporator freeze up.

On the RTWA and RTUA units, the controller will initiate the "RUN:UNLOAD" mode to terminate a cycle from any of the following:

- STOP key pressed
- Loss of load

Installation - Electrical

- Low ambient run inhibit
- External AUTO/STOP input opened

The "RUN:UNLOAD" operating mode commands the compressors to completely unload, which takes about 1/2 minute. This will allow the compressors to be totally unloaded for the next startup. If only the proof of chilled water flow interlock is used, the chiller will shut down on an immediate (non-friendly) shutdown and initiate an automatic reset diagnostic.

Figure 27 shows a typical interlock of an RTWA or RTUA chiller. There are three terminals (six wires) on the chiller that are required to be connected.

1. External Auto/Stop (Terminals 1U1TB3-3 and -4).

This input is supplied by the field. A contact closure will start the chiller water pump and chiller, via the UCM pump control contacts. Opening the contact will put the operating compressors into the "RUN: UNLOAD" mode and initiate a timing period (1 to 30 minutes, adjustable through the Clear Language Display). This will delay termination of the chilled water pump operation via the UCM pump control contacts. Examples of the input at terminals 1U1TB3-3 and -4 would be a time clock, ambient thermostat, building automation system, etc.

2. UCM Pump Control Contacts (Terminals 1U1TB4-8 and -9).

This output is a set of contacts that will close and start the chilled water pump when the external Auto/Stop contacts are closed. When the contacts are opened, 1 to 30 minutes later (adjustable through the Clear Language Display), the UCM pump contacts open.

3. Proof of Chilled Water Flow Interlock (Terminals 1U1TB3-1 and -2).

This terminal must be field installed. Contact closure between the terminals indicate proof of chilled water flow. Examples of this is a pump starter auxiliary contact, flow switch, differential pressure switch, or a contact from a building automation system (see "[Chilled Water Flow Switch on Page 33](#)"). Opening of this contact will immediately shutdown the chiller and initiate an automatic reset diagnostic, indicating loss of chilled water flow.

Condenser Water Pump

For the condenser water pump interlock on the RTWA units, connect leads 565 and 566 between terminals 1TB4-1 AND 1TB4-2 in the upper portion of the control panel and the condenser water pump control. The circuit is 115 VAC and the load is not to exceed 1150 VA inrush, 115 VA sealed.

This will interlock the condenser water pump operation with the unit operation. This insures that the condenser water pump is operating before the compressor(s) are started.

Installation - Electrical

Also, provide a set of auxiliary contacts for condenser water pump starter 5K1 to interlock cooling tower fan starter (5K28) operation (if used) with the condenser water pump starter. This insures that the cooling tower fan runs only when the condenser water pump is operating.

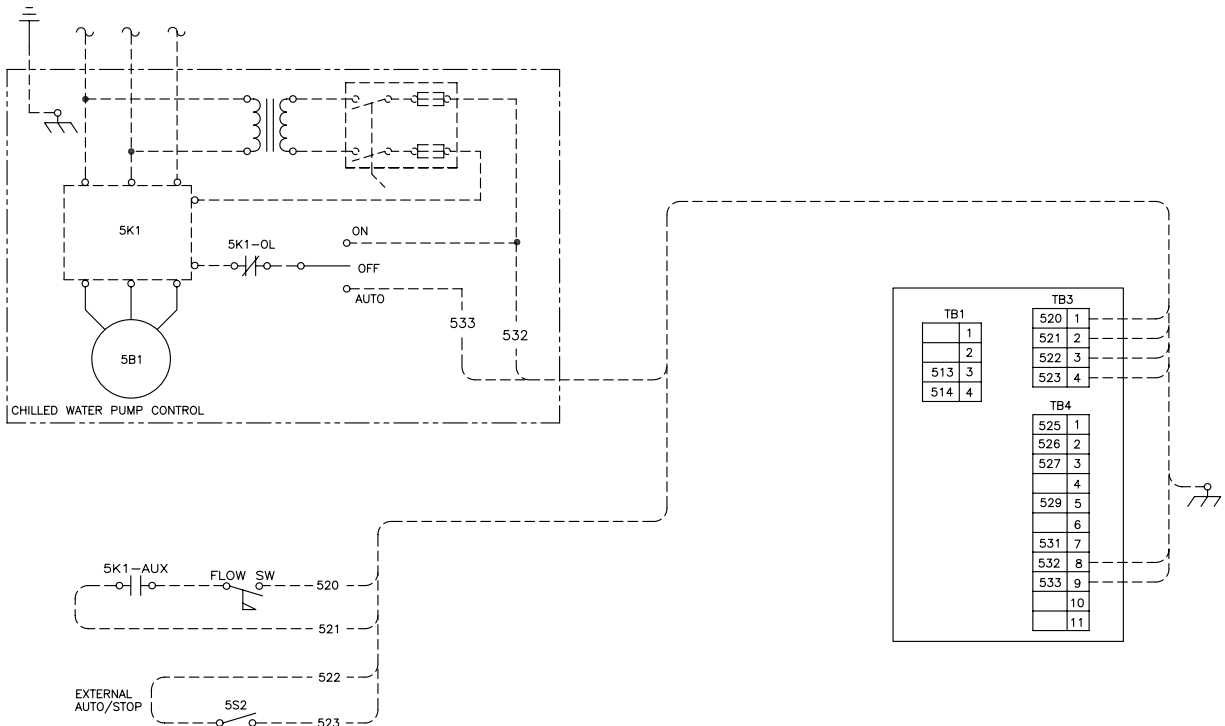

Figure 27 Typical RTWA Chiller Interlock

Alarm/Running/Maximum Capacity Outputs

Terminals 1 to 7 on terminal strip TB4 of the 1U1 board provide a variety of contact outputs on the RTWA and RTUA units. These are dependent upon the setting of Programmable Relay Setup (Service Setting Menu) and its relationship to diagnostics, compressors operating and the system operating at full capacity.

As shown in [Figure 19](#), there are three relays. Relays 1 has SPDT contacts. Relays 2 and 3 have SPST normally-open contacts. The relays provide three output configurations, as shown in [Figure 19](#), and each configuration offers four choices as to how each relay is to respond to a set of diagnostics.

[Table 27](#) shows the twelve settings available in Programmable Relay Setup (Service Setting Menu) and the diagnostics which are issued for each set of conditions.

Alarm/Running/Maximum Capacity Indicator Wiring

If the optional remote Alarm/Running/Maximum Capacity contacts are used, provide electrical power, 115 VAC (contact load not to exceed 1150 VA inrush, 115 VA sealed), with fused-disconnect to a customer furnished remote device. Also provide proper remote device ground connection.

Installation - Electrical

Table 19 Alarm/Running/Maximum Capacity Relay Output Configurations

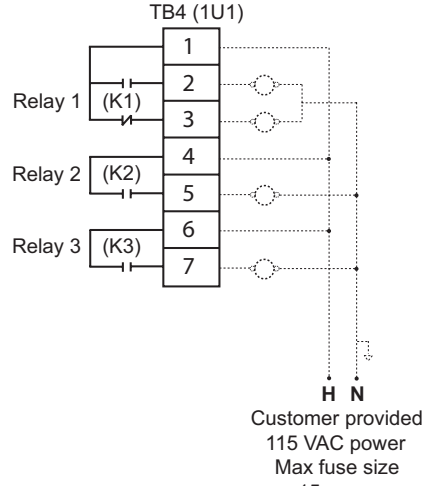
Relay Output Configuration		Contact Outputs
1:	RLY 1 = Alarm RLY 2 = Compressor Running RLY 3 = Maximum Capacity	
2:	RLY 1 = Circuit 1 Alarm RLY 2 = Circuit 2 Alarm RLY 3 = Maximum Capacity	
3:	RLY 1 = Alarm RLY 2 = Circuit 1 Running RLY 3 = Circuit 2 Running	

To install the available remote running and alarm indication, the installer must provide leads 525 thru 531 from the panel to the proper terminals of terminal strip 1U1TB4 on the UCM. Refer to the Section on “Unit Wiring” and the field diagrams which are shipped with the unit.

Table 20 Alarm/Running/Maximum Capacity Menu Settings

Programmable Relay Setup Setting (Service Setting Menu)	Relays Output Configuration Table 19	Diagnostics that the Alarm Relay(s) is Active		
		MMR/CMR diag.	MAR/CAR diag.	IFW
1	1	YES	NO	NO
2	1	YES	YES	NO
3	1	YES	YES	YES
4	1	YES	NO	YES
5	2	YES	NO	NO
6	2	YES	YES	NO
7	2	YES	YES	YES
8	2	YES	NO	YES
9	3	YES	NO	NO
10	3	YES	YES	NO
11	3	YES	YES	YES

Notes:
 MMR = Machine Manual Reset
 CMR = Circuit Manual Reset
 MAR = Machine Auto Reset
 CAR = Circuit Auto Reset
 IFW = Informational Warnings



Installation - Electrical

Table 20 Alarm/Running/Maximum Capacity Menu Settings

Programmable Relay Setup Setting (Service Setting Menu)	Relays Output Configuration Table 19	Diagnostics that the Alarm Relay(s) is Active		
		MMR/CMR diag.	MAR/CAR diag.	IFW
12	3	YES	NO	YES

Notes:
 MMR = Machine Manual Reset
 CMR = Circuit Manual Reset
 MAR = Machine Auto Reset
 CAR = Circuit Auto Reset
 IFW = Informational Warnings

Interconnecting Wiring between RTUA Units and an Air-Cooled Condenser

RTCA condensers need the following interconnecting wiring from the RTUA unit. Refer to [Figure 28](#):

- RTUA 1TB9-1 to -8 to RTCA 1TB9-1 to -8, respectively, for controlling the fan inverters.
- RTUA 1TB6-1 to -2 to RTCA 1TB6-1 to -2, respectively, to monitor the factory-installed outdoor air temperature sensor.
- RTUA 1TB6-3 and -4 to RTCA 1TB6-3 and -4, respectively, to monitor the factory-installed saturated condensing refrigerant temperature sensor on Circuit #2.
- RTUA 1TB6-5 and -6 to RTCA 1TB6-5 and -6, respectively, to monitor the factory-installed saturated condensing refrigerant temperature sensor on Circuit #1.
- 115 volt power from the RTUA 1TB4-3 to -11 to RTCA 1TB4-3 to -11, respectively, to control the fan contactors

Non-RTCA condensers need the following interconnecting wiring from the RTUA unit. Refer to [Figure 29](#):

- The field-installed outdoor air temperature sensor on the condenser needs to be wired to RTUA 1TB8-1 and -2.
- The field installed saturated condensing refrigerant temperature sensor for circuit #2 needs to be wired to RTUA 1TB8-3 and -4.
- The field installed saturated condensing refrigerant temperature sensor for circuit #1 needs to be wired to RTUA 1TB8-5 and -6.
- The 115 volt signal to start fans on Circuit #2 comes from RTUA 1TB4-3.
- The 115 volt signal to start fans on Circuit #1 comes from RTUA 1TB4-7.
- GROUND return for the 115 volt fan signal connects to RTUA 1TB4-11

NOTE: If sensor leads are not long enough to make connection at RTUA, refer to Paragraph "Sensor Connections from Non-RTCA Unit to RTUA on Page" 74.

NOTE: Staging of the fans of a non-RTCA condenser is the responsibility of the customer.



Installation - Electrical

Low Voltage Wiring

The remote devices described below require low voltage wiring. All wiring to and from these remote input devices to the UCM, as described below in Paragraphs ["Emergency Stop \(Normal Trip\) on Page" 67](#) through ["Outdoor Air Temperature Sensor on Page" 74](#), are for RTWA and RTUA units only and must be made with shielded, twisted-pair conductors. Be sure to ground the shielding only at the Clear Language Display. Refer to the Section on ["Unit Wiring"](#) for the recommended conductor sizes.

NOTE: To prevent control malfunctions, do not run low voltage wiring (<30 V) in conduit with conductors carrying more than 30 volts.

Emergency Stop (Normal Trip)

The Clear Language Display provides auxiliary control for a customer specified/installed latching trip out. When this customer-furnished remote contact (5K18) is provided, the chiller will run normally when the contact is closed. When the contact opens, the unit will trip off on a manually resettable diagnostic. This condition requires manual reset at the chiller switch on the front of the Clear Language Display.

To connect, first remove the jumper located between terminals 3 and 4 of 1U1TB1. Connect low voltage leads 513 and 514 to those terminals. Terminal strip locations are shown in Section ["Unit Wiring"](#). Refer to the field diagrams which are shipped with the unit.

Silver or gold-plated contacts are recommended. These customer furnished contacts must be compatible with 12 VDC, 45 mA resistive load.

External Circuit Lockout - Circuit #1

The UCM provides for auxiliary control via a customer specified or installed contact closure, for individual operation of Circuit #1. If the contact is closed, the refrigerant circuit will not operate. The refrigerant circuit will run normally when the contact is opened. This feature is used to restrict total chiller operation, eg. during emergency generator operations.

External circuit lockout will only function if External Circuit Lockout (Service Setting Menu) is enabled.

These customer-supplied contact closures must be compatible with 12 VDC, 45 mA resistive load. Silver or gold plated contacts are recommended.

To install, cut, strip and wire-nut existing wire loop #W7 on the J3 connector of the 1U4 module to low voltage leads 45A and 45B. Connections are shown in the field diagrams which are shipped with the unit.

External Circuit Lockout - Circuit #2

The UCM provides for auxiliary control via a customer specified or installed contact closure, for individual operation of Circuit #2. If the contact is closed, the refrigerant circuit will not operate. The refrigerant circuit will run normally when the contact is opened. This feature is used to restrict total chiller operation, eg. during emergency generator operations.

External circuit lockout will only function if External Circuit Lockout (Service Setting Menu) is enabled.

These customer-supplied contact closures must be compatible with 12 VDC, 45 mA resistive load. Silver or gold plated contacts are recommended.

To install, cut, strip and wire-nut existing wire loop #W4 on the J3 connector of the 1U5 module to low voltage leads 46A and 46B. Connections are shown in Section ["Refrigerant Charging"](#) and in the field diagrams which are shipped with the unit.



Installation - Electrical

Ice Making Option

Ice Machine Control (Operator Setting Menu) must be Enabled. The UCM provides auxiliary control for a customer specified/installed contact closure for ice making. When contact (5K20) is provided, the chiller will run normally when the contact is open. Upon contact closure, the UCM will initiate an ice-building mode, in which the unit runs fully loaded at all times. Ice-building shall be terminated either by opening the contact or based on the entering evaporator water temperature setting under Active Ice Termination Setting (Chiller Report Menu). The UCM will not permit the ice-building mode to be reentered until the unit has been switched out of ice-building mode (open 5K20 contacts) and then switched back into ice-building mode (close 5K20 contacts). In ice-building, the current setpoint will be set at 120%. For example, if the Front Panel or External Current Limit setpoint is set to 80%, in icebuilding the Active Current Limit is 120%.

If, while in ice-building mode, the unit gets down to the freezestat setting (water or refrigerant), the unit will shut down on a manually resettable diagnostic, just as in normal operation.

Installation - Electrical

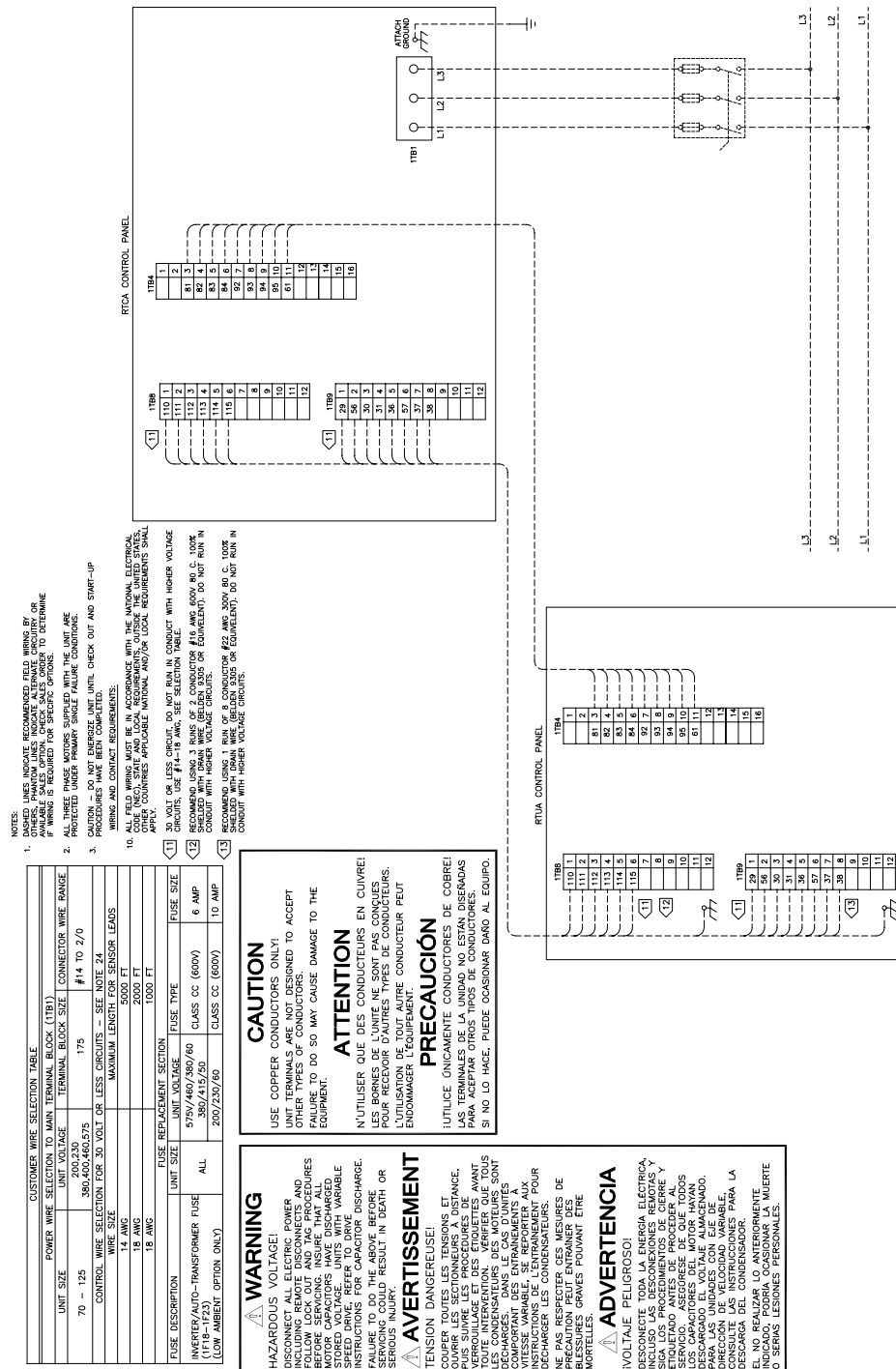

Figure 28 Interconnecting Wiring from RTUA to RTCA

Installation - Electrical

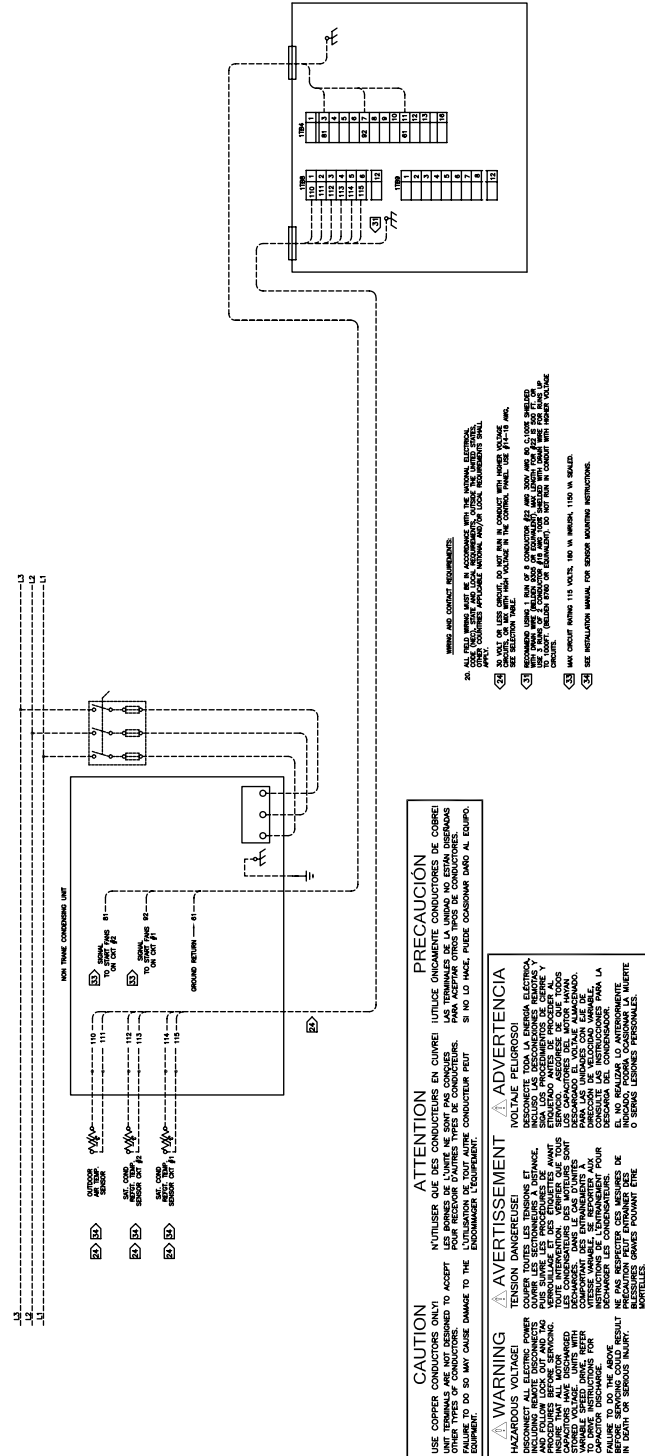

Figure 29 Interconnecting Wiring from RTUA to Non-RTCA Condensing Unit

Installation - Electrical

Connect leads 501 and 502 from 5K20 to the proper terminals IU2TB1-1 and -2, as shown in Section "Unit Wiring on Page" 155. Refer to the field diagrams which are shipped with the unit.

Silver or gold-plated contacts are recommended. These customer furnished contacts must be compatible with 12 VDC, 45 mA resistive load.

External Chilled Water Setpoint: Remote Resistor/Potentiometer, Voltage Source 2-10 VDC, or Current Source 4-20 mA

This option allows the external setting of the Chilled Water Setpoint, independent of the Front Panel Chilled Water Setpoint, by one of three means:

1. A remote resistor/potentiometer input (fixed or adjustable)
2. An isolated voltage input 2-10 VDC
3. An isolated current loop input 4-20 mA

To enable external setpoint operation, External Chilled Water Setpoint (Operator Setting Menu) should be set to "E" using the Clear Language Display

1. Remote Resistor/Potentiometer Input (fixed or adjustable)

Connect the remote resistor and/or potentiometer to terminals TB1-4 and TB1-5 of Options Module 1U2, as shown in Figure 30.

For units with 40 F to 60 F LCWS range, a field furnished 25 Kohm linear taper potentiometer ($\pm 10\%$) and a fixed 5.6 Kohm ($\pm 10\%$) 1/4 Watt resistor should be used.

For units with 20 F to 39 F LCWS range, a field furnished 25 Kohm linear taper potentiometer ($\pm 10\%$) and a fixed 15 Kohm ($\pm 10\%$) 1/4 Watt resistor should be used.

If the potentiometer is to be remotely mounted, it and the resistor must be connected to the UCM prior to mounting. Then, with the Clear Language Display showing "Active Chilled Water Setpoint" (Chiller Report Menu), the Clear Language Display can be used to calibrate the positions of the potentiometer to correspond with the desired settings for the leaving water temperature. External resistor input values for various chilled water setpoints are shown in Table 21.

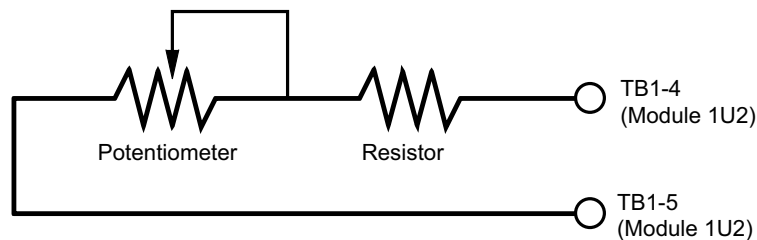

Figure 30 Resistor and Potentiometer Arrangement for External Chilled Water Setpoint



Installation - Electrical

Table 21 Input Values Vs. External Chilled Water Setpoint

Inputs			Resulting Chilled Water Setpoint (F)
Resistance (Ohms)	Current (ma)	Voltage (Vdc)	
944330	4.0	2.0	0.0
686092	5.2	2.6	5.0
52946	6.5	3.2	10.0
42434	7.7	3.9	15.0
34889	8.9	4.5	20.0
29212	10.2	5.1	25.0
24785	11.4	5.7	30.0
21236	12.6	6.3	35.0
18327	13.8	6.9	40.0
15900	15.1	7.6	45.0
13844	16.3	8.2	50.0
12080	17.5	8.8	55.0
10549	18.8	9.4	60.0
9050	20.0	10.0	65.0

2. Isolated 2-10 VDC Voltage Source Input.

Set DIP Switch SW1-1 of Options Module 1U2 to "OFF." Connect the voltage source to terminals TB1-4 (+) and TB1-5 (-) on Options Module IU2. CWS is now based on the following equation:

$$CW \text{ Setpoint } ^\circ F = (VDC \times 8.125) - 16.25$$

Sample values for CWS vs. VDC signals are shown in [Table 21](#).

$$\text{Minimum setpoint} = 0^\circ F (2.0 \text{ VDC input})$$

$$\text{Maximum setpoint} = 65^\circ F (9.4 \text{ VDC input})$$

$$\text{Maximum continuous input voltage} = 15 \text{ VDC}$$

$$\text{Input impedance (SW1-1 off)} = 40.1 \text{ Kohms}$$

3. Isolated 4-20 mA Current Source Input.

Set DIP Switch SW1-1 of Options Module 1U2 to "ON." Connect the current source to terminals TB1-4 (+) and TB1-5 (-). CWS is now based on the following equation:

$$\text{Setpoint } ^\circ F = (mA \times 4.0625) - 16.25$$

Sample values for CWS vs., mA signals are shown in [Table 21](#).

$$\text{Minimum setpoint} = 0^\circ F (40mA)$$

$$\text{Maximum setpoint} = 65^\circ F (18.8 \text{ mA})$$

$$\text{Maximum continuous input voltage} = 30 \text{ mA}$$

$$\text{Input impedance (SW1-1 on)} = 499 \text{ ohms}$$

NOTE: The negative terminal TB1-5 is referenced to the UCM chassis ground. To assure correct operation, 2-10 VDC or 4-20 mA signals must be

Installation - Electrical

isolated or “floating” with respect to the UCM chassis ground. Refer to the Section “Unit Wiring”.

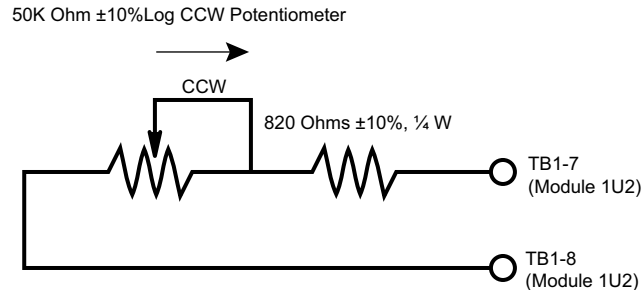

Figure 31 Resistor and Potentiometer Arrangement for External Current Limit Setpoint

If the potentiometer is to be remotely mounted, it and the resistor must be connected to the UCM prior to mounting. Then, with the Clear Language Display showing “Active Current Limit Setpoint” (Chiller Report Menu), the Clear Language Display can be used to calibrate the positions of the potentiometer to correspond with the desired settings for the current limits. External resistor input values for various current limit setpoints are shown in [Table 28](#).

4. VDC Voltage Source Input

Set DIP Switch SW1-2 of Options Module 1U2 to “OFF.” Connect the voltage source to terminals TB17 (+) and TB1-8 (-) of Options Module 1U2. CLS is now based on the following equation:

$$\text{CL Setpoint\%} = (\text{VDC} \times 10) + 20$$

Sample values for CLS vs. VDC signals are shown in [Table 21](#).

Minimum setpoint =	40% (2.0 VDC input)
Maximum setpoint =	120% (10.0 VDC input)
Maximum continuous input voltage =	15 VDC
Input impedance (SW1-1 on) =	40.1 Kohms
(SW1-2 off)	

5. 4-20 mA Current Source Input

Set DIP Switch SW1-2 of Options Module 1U2 to “ON.” Connect the current source to terminals T131-7 (+) and TB1-8 (-) of Options Module 1U2. CLS is now based on the following equation:

$$\text{CL Setpoint\%} = (\text{mA} \times 5) + 20$$

Sample values for CLS vs. mA signals are shown in [Table 22](#).

Minimum setpoint =	40% (0 mA)
Maximum setpoint =	120% (20.0 mA)
Maximum continuous input voltage =	30 mA
Input impedance =	499 ohms
(SW1-2 on)	

NOTE: The negative terminal TB1-8 is referenced to the UCM chassis ground. To assure correct operation, 2-10 VDC or 4-20 mA signals must be isolated or “floating” with respect to the UCM chassis ground. Refer to the Section “Unit Wiring”.



Installation - Electrical

Table 22 Input Values Vs. External Current Limit Setpoint

Inputs			Resulting Chilled Water Setpoint (%RLA)
Resistance (Ohms)	Current (ma)	Voltage (Vdc)	
49000	4.0	2.0	40
29000	6.0	3.0	50
19000	8.0	4.0	60
13000	10.0	5.0	70
9000	12.0	6.0	80
6143	14.0	7.0	90
4010	16.0	8.0	100
2333	18.0	9.0	110
1000	20.0	10.0	120

Sensor Connections from Non-RTCA Unit to RTWA

If the sensor leads are not long enough to reach the desired sensor termination point on the RTUA, follow the procedures below:

1. Cut the sensor leads off, 6" from the sensors.
2. Butt-splice the sensor leads to a shielded, twistedpair cable conductor (Belden 8760 or equivalent).
3. Slide one piece of the shrink tubing provided over the spliced area.
4. Apply heat to the spliced area until the tubing shrinks, making a weather-proof seal.

CAUTION: Control Malfunctions!

To prevent control malfunctions, do not run low voltage wiring (30V or less) in conduit with higher voltage circuits.

Outdoor Air Temperature Sensor

This sensor is used for low ambient lockout and chilled water reset by outdoor air. It ships with all RTCA units and is optional on the RTUA and RTWA units.

Remove the sensor from its shipping location in the control panel and install it in the fresh air intake or on the north wall of the building. Protect the sensor from direct sunlight and shelter it from the elements (RTWA only).



Installation - Electrical

Table 23 Input Values Vs. External Current Limit Setpoint

Resistance (Ohms)	Inputs		Resulting Chilled Water Setpoint (%RLA)
	Current (ma)	Voltage (Vdc)	
49000	4.0	2.0	40
29000	6.0	3.0	50
19000	8.0	4.0	60
13000	10.0	5.0	70
9000	12.0	6.0	80
6143	14.0	7.0	90
4010	16.0	8.0	100
2333	18.0	9.0	110
1000	20.0	10.0	120

Connect leads from 5RT3 to terminals 1U1 TB1-1 and TB-2 wiring to and from the remote sensor must be made with shielded, twisted-pair conductors. Be sure to ground the shielding only at the UCM. Apply tape to the sensor end of the shielding to prevent it from contacting any surface.

⚠ WARNING

Hazardous Voltage w/Capacitors!

Disconnect all electric power, including remote disconnects before servicing. Follow proper lockout/tagout procedures to ensure the power cannot be inadvertently energized. For variable frequency drives or other energy storing components provided by Trane or others, refer to the appropriate manufacturer's literature for allowable waiting periods for discharge of capacitors. Verify with an appropriate voltmeter that all capacitors have discharged. Failure to disconnect power and discharge capacitors before servicing could result in death or serious injury.

Note: For additional information regarding the safe discharge of capacitors, see PROD-SVB06A-EN or PROD-SVB06A-FR

CAUTION

Use Copper Conductors Only!

Unit terminals are not designed to accept other types of conductors. Failure to use copper conductors may result in equipment damage.

Optional Bidirectional Communications Link (BCL)

This option allows the Clear Language Display in the control panel on RTWA and RTUA units to exchange information (eg. operating setpoints and Auto/Standby commands) with a higher level control device, such as a Tracer, a



Installation - Electrical

multiple-machine controller or a remote display panel. A shielded, twisted-pair connection establishes the bidirectional communications link between the unit control panel and the Tracer, multiple-machine controller or remote display panel.

NOTE: The shielded, twisted-pair conductors must run in a separate conduit.

Field wiring for the communication link must meet the following requirements:

1. All wiring must be in accordance with the NEC and local codes.
2. Communication link wiring must be shielded, twisted-pair wiring (Belden 8760, or equivalent). Refer to the Section "[Refrigerant Charging](#)" for wire size.
3. The maximum total wire length for each communication link is 5,000 feet.
4. The communication link cannot pass between buildings.
5. All UCM's on the communication link can be connected in a "daisy chain" configuration.

Communication Link Connection Procedure

1. Refer to the Tracer installation literature to determine proper communication link termination connections at the Tracer unit.
2. Refer to the "[Remote Clear Language Display Installation Procedure on Page 77](#)", to determine termination points at a remote Clear Language Display.
3. Connect the shield of the communication link wiring to the designated shield terminal at the Tracer unit.
4. Connect leads 561 and 562 from the proper terminals of 1U2 TB2-1 and TB2-2 on the UCM to the Tracer. There is no polarity requirement for this connection.
5. At the UCM, the shield should be cut and taped to prevent any contact between the shield and ground.

NOTE: On multiple-unit installations, splice the shielding of the two twisted-pairs that come into each UCM in the "daisy chain" system. Tape the spliced connections to prevent any contact between the shield and ground. At the last Clear Language Display in the chain, the shield should be cut and taped off.

6. To get the chiller to communicate with a Tracer on a multiple-unit controller, the ICS address under the "Service Settings" menu must be set and the optional 1U2 module must be installed. The Tracer will look for chiller addresses 55, 56, 57, 58, 59 or 60. Each chiller must have a unique address.

LonTalk Communication Interface (LCI-C)

The Tracer LCI-C interface acts as a translator between Trane's IPC (Inter-Processor Communication) and Echelon's LonTalk® communications protocol (ANSI/EIA/CEA 709.1). This allows the chiller to communicate with building automation systems which also communicate using the LonTalk® protocol. The LonTalk® communications protocol also allows for peer to peer commu-



Installation - Electrical

communications between controllers so they can share information. Communicated setpoints have priority over locally wired inputs to the controller unless the controller is set to the "Local" control mode.

The LCI-C module provides connectivity to Trane's Rover® service tool for proper configuration of the LCI-C module.

NOTE: LonTalk® communication links are not polarity sensitive.

1. Connect BAS leads to J3-1,2 or J3-3,4.

Remote Clear Language Display Installation Procedure

The Remote CLD is intended for indoor use and is not weatherproof. It can be used with both RTWA or RTUA units. It is mounted in a molded rubber plastic box with a molded rubber keypad. Although this is not the same as the membrane keyboard of the unit's CLD, the key locations and labels are identical.

Field wiring for the communication link must meet the following requirements:

1. All wiring must be in accordance with the NEC and local codes.
2. Communication link wiring must be 18 AWG shielded, twisted-pair wiring (Belden 8760, or equivalent).
3. The maximum total wire length for each communication link is 5,000 feet.
4. The communication link cannot pass between buildings.

Installation - Electrical

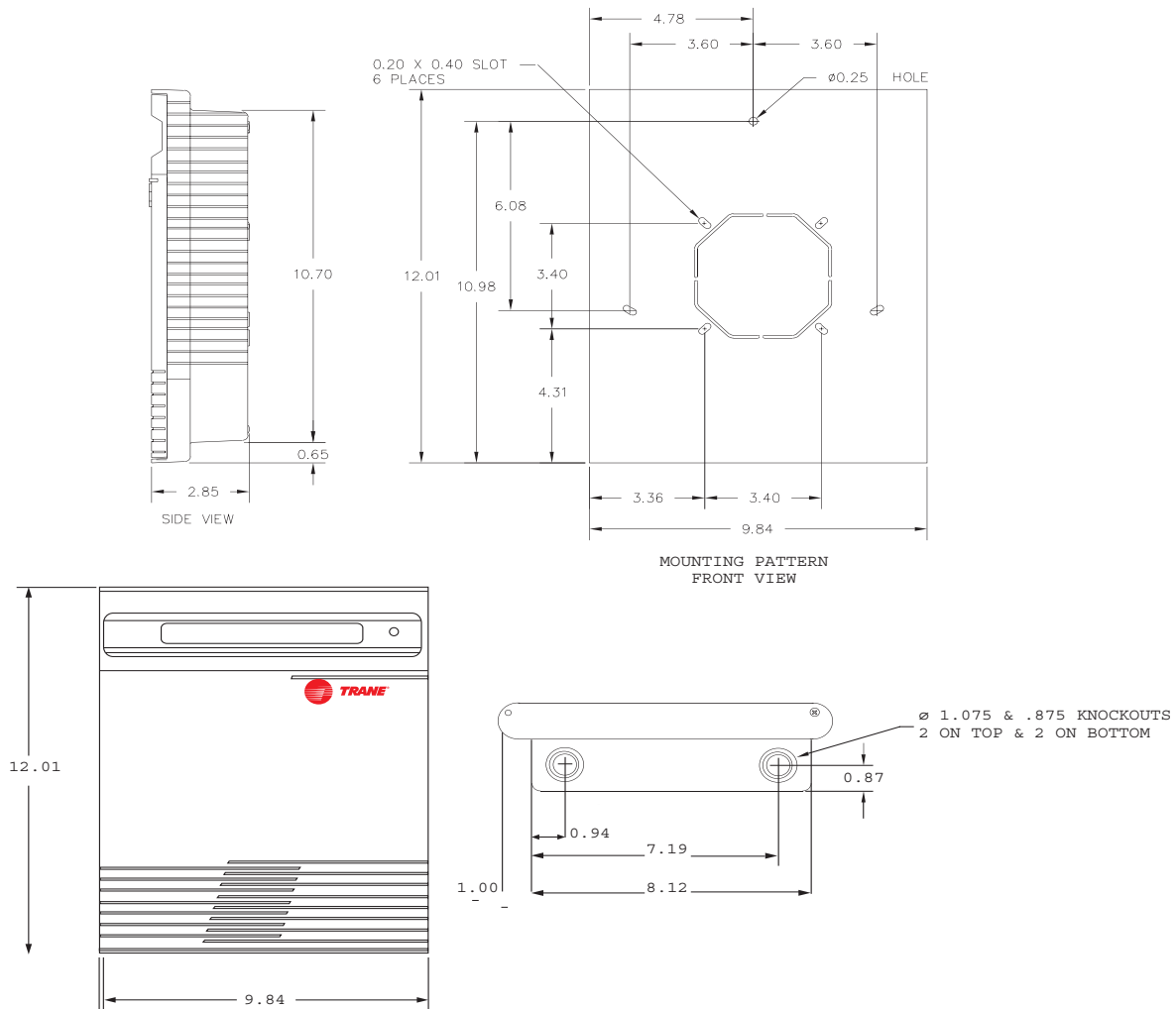

Figure 32 Remote CLD Panel Mounting Holes and Electrical Access Knockouts

Remote CLD Mounting

All mounting hardware (tools, screws, etc.) is to be field supplied. [Figure 32](#) shows the mounting holes in the back of the Remote CLD panel. Also shown are the electrical access knockouts at the bottom and top of the panel. Remove the knockouts that will be used for wire entry, prior to mounting the panel.

NOTE: On the back of the panel is a knockout for an electrical outlet box, if one is to be used.

Prior to mounting the panel, the actual keypad board needs to be swung open. To swing the keypad board out of the way, remove the two screws on the right side of the keypad. With the screws removed, the keypad board can be swung to the left, to obtain access to the mounting holes.

Attach the display box to the mounting surface with screws through the mounting hole and two mounting slots, show in [Figure 32](#).

Installation - Electrical

NOTE: If an electrical box is to be used, attach it to the display box with screws through the four mounting slots around the knockout.

The top of the display box is marked "TOP." Note the position of the box before mounting it to the surface. With the box in the desired position against the mounting surface, mark the location of the mounting holes.

Remove the box and drill the necessary holes in the surface. Put the display box back in position and secure it to the mounting surface with the required screws.

The keypad board can now be swung back into position and secured.

Remote CLD Panel Wiring

The Remote CLD requires a 24-volt power source and a shielded, twisted-pair wire between the panel and the Clear Language Display. See [Figure 34](#).

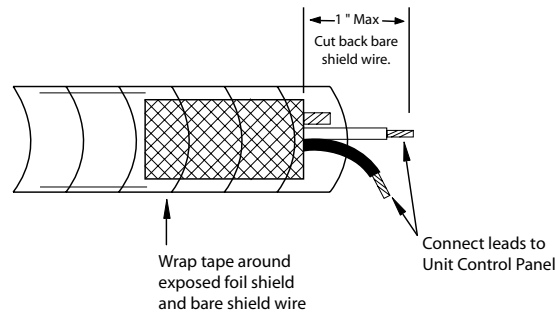

Figure 33 Shielded, Twisted Pair Communication Link at the Remote CLD Panel

As shown in [Figure 34](#), the wire runs from terminals J3A-1(+) and J3A2(-) in the unit's buffer module (1U7) to terminals (+) and (-) in the Remote CLD. Be sure that one lead is connected to the (+) terminal at each end and the other lead is connected to the (-) terminal at each end.

Do not run the shielded, twisted-pair wire in a conduit that also contains circuits of greater than 30 volts. Attach the shield to a grounding lug in the Remote CLD Panel. Cut and tape the shield at the Unit Control Panel, as shown in [Figure 33](#).

NOTE: Shielding of the twisted pair can be grounded at either the Unit Control Panel or the Remote CLD Panel as long as both sides are NOT grounded.

Connect the 24-volt power supply to terminals J2-A and J2-B in the Remote CLD panel. The polarity of the power source is not a concern, but the power source must be grounded to terminal J2 GND.

NOTE: A field-supplied Class 2, 24 VAC, 40 VA transformer can be used as a power supply for the Remote CLD Panel.

NOTE: Both a Remote CLD and a Tracer unit can be connected to the UCM.

ICS Address Setting

The setting of the ICS address for the Remote CLD is not necessary.

Multiple Unit Operation

In a multiple unit configuration, the Remote CLD panel has the capability to communicate with up to four units. Each unit requires a separate communication link with the Remote CLD panel.

Installation - Electrical

Terminal strip TB4 is used to wire the second, third, and fourth units to the Remote CLD. TB4 is labeled as shown below:

1	2	3	4	5	6	7	8	9
+	-	⚡	+	-	⚡	+	-	⚡

Terminals 1-3 are for the second unit.

Terminals 4-6 are for the third unit.

Terminals 7-9 are for the fourth unit.

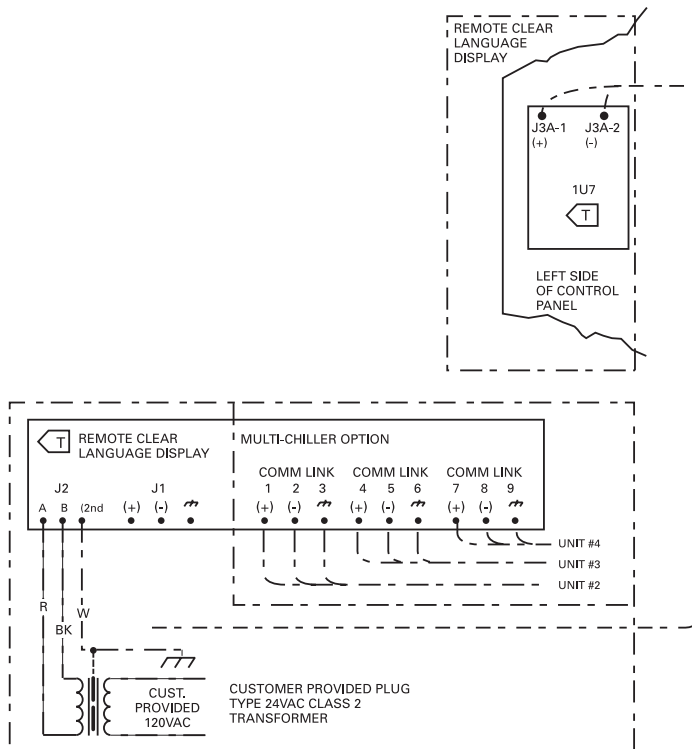

Figure 34 Remote Display Panel Interconnecting Wiring



Installation - Electrical

Installation Checklist

Complete this checklist as the unit is installed, to verify that all recommended procedures are accomplished before the unit is started. This checklist does not replace the detailed instructions given in the Sections 2 and 3 of this manual. Read both sections completely, to become familiar with the installation procedures, prior to beginning the work.

Receiving

- Verify that the unit nameplate data corresponds to the ordering information.
- Inspect the unit for shipping damage and any shortages of materials. Report any damage or shortage to the carrier.

Unit Location and Mounting

- Inspect the location desired for installation and verify adequate service access clearances.
- Provide drainage for evaporator and condenser water, if applicable.
- Remove and discard all shipping materials (cartons, etc.)
- Install optional neoprene or spring isolators, if required.
- Level the unit and secure it to the mounting surface.

Unit Water Piping

- Flush all unit water piping before making final connections to the unit.
- Connect the water piping to the evaporator and condenser, if applicable.
- Install pressure gauges and shutoff valves on the water inlet and outlet to the evaporator, if applicable.
- Install a water strainer in the entering chilled water line.
- Install a balancing valve and flow switch (discretionary) in the leaving chilled water line, if applicable.
- Install a drain with shutoff valve or a drain plug on the evaporator, if applicable.
- Vent the chilled water and condenser water system at high points in the system piping, if applicable.

Unit Refrigerant Piping (RTUA and RTCA)

NOTE: Do not release refrigerant to the atmosphere!

- Perform initial leak test.
- Braze properly sized and constructed liquid line to liquid line connections on the unit.
- Braze properly sized and constructed hot gas (discharge) lines at hot gas line connections on the unit.
- Leak test the unit and all refrigerant piping connections.
- Connect the unit power supply wiring with fused disconnect to the terminal block (or unit-mounted disconnect) in the power section of the control panel.
- Connect the control power supply wiring with fused-disconnect to the



Installation - Electrical

terminal strip in the power section of the control panel, if applicable.

- Connect power supply wiring to the chilled water pump and condenser water pump, if applicable.
- Connect power supply wiring to the RTCA fans, if applicable.
- Check Interlock Wiring, including External Auto/Stop (terminals 1U1TB3-3 and -4), UCM Pump Control Contacts (terminals 1U1TB4-8 and -9) and Proof of Chilled water Flow Interlock (terminals 1U1TB3-1 and -2), if applicable.
- If the remote running/alarm indicator contacts are used, install leads 525 thru 531 from the panel to the proper terminals on terminal strip 1U1, TB4.
- If the emergency stop function is used, remove the factory-installed jumper and install low voltage leads 513 and 514 to terminals 3 and 4 of 1U1, TB1.
- If indoor zone temperature is to be used, install leads 501 and 502 on 6RT4 to the proper terminals on 1U2, TB1.
- If the ice making option is used, install leads 501 and 502 on 5K20 to the proper terminals on 1U2, TB1.
- If the Remote Clear Language Display is used, install the 24 VAC customer-supplied transformer to the proper terminals on J2. Also connect the twisted-pair wires from the 1U7 module in the unit to the proper terminals in the Remote Clear Language Display panel.
- On RTUA units, connect all low voltage wiring between RTUA and air-cooled condenser.

Operating Principles

RTWA Units

This section describes the mechanical operating principles of Series R water-cooled chillers equipped with microcomputer-based control systems.

The 70-125-ton Model RTWA units are dual compressor, helical-rotary type water-cooled liquid chillers. The basic components of an RTWA unit are:

- Clear Language Display and control modules
- Helical-rotary compressor
- Direct expansion evaporator
- Water-cooled condensers
- Oil supply system (hydraulic and lubrication) - Interconnecting piping

Components of a typical RTWA unit are identified in [Figures 35](#).

RTUA Units

The 70-125 ton RTUA units are dual compressor, helical-rotary type compressor chillers. The basic components of an RTUA unit are:

- Clear Language Display and control modules
- Helical rotary compressors
- Direct expansion evaporator
- Oil cooler
- Interconnecting piping between the compressors and evaporator

Components of a typical RTUA are identified in [Figures 36](#).

RTCA Units

The 70-125 ton RTCA units are air-cooled condensing units. The basic components of an RTCA unit are:

- Terminal box
- Air-cooled condenser
- One (1) fan inverter per circuit - Optional

Components of a typical RTCA are identified in [Figures 36](#).

Operating Principles

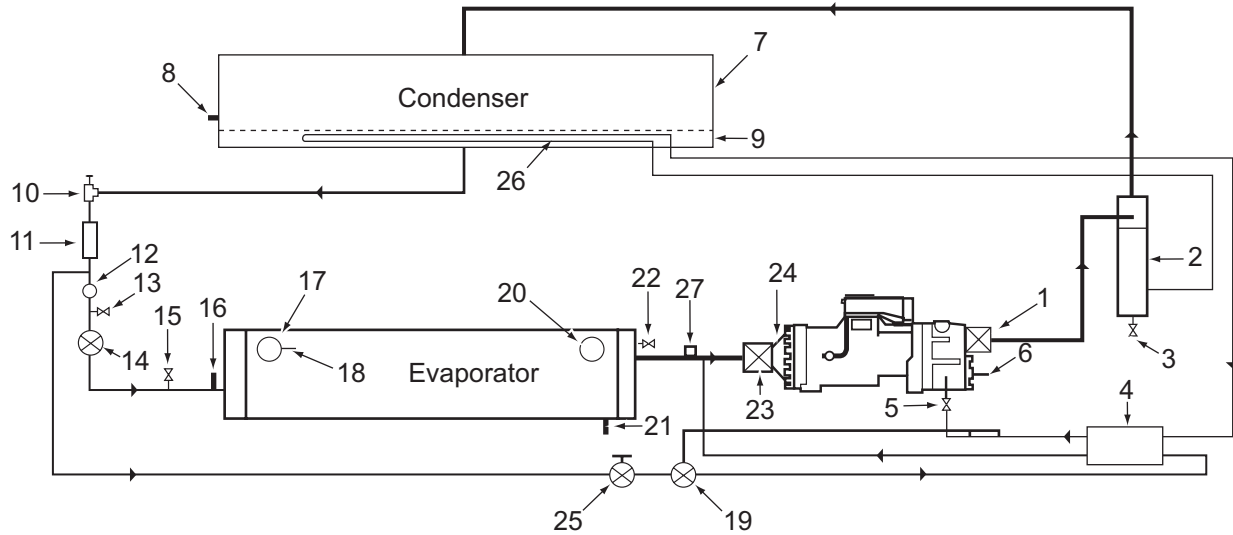

Figure 35 RTWA Refrigeration System and Control Components

- | | | |
|--|--|--|
| 1. Discharge Service Valve | 11. Filter/Dryer | 20. Entering Water Connection |
| 2. Oil Separator | 12. Sight Glass | 21. Evaporator Entering Water Temp. Sensor |
| 3. 1/4" Angle Valve | 13. Schrader Valve | 22. Relief Valve |
| 4. Oil Cooler (if digit 17 is a "V") | 14. Electronic Expansion Valve | 23. Suction Service Valve |
| 5. Oil Line Service Valve | 15. 1/4" Angle Valve | 24. Comp Suction Refrigerant Temp. Sensor |
| 6. Oil Temperature Sensor | 16. Sat. Evaporator Refrigerant Temp. Sensor | 25. Shutoff Valve |
| 7. Condenser | 17. Leaving Water Connection | 26. Oil Cooler |
| 8. Sat. Condenser Refrigerant Temp. Sensor | 18. Evaporator Leaving Water Temp. Sensor | 27. Low Pressure Switch |
| 9. Subcooler | 19. Temp Responsive Valve Optional | |
| 10. Liquid Line Service Valve Backseat Port Upstream | | |

Operating Principles

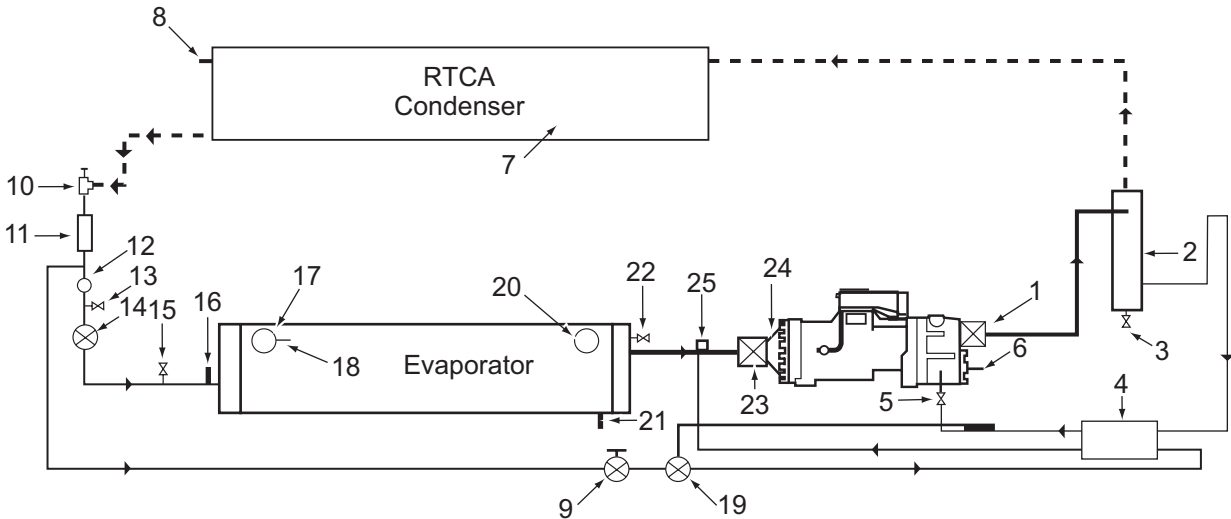

Figure 36 RTUA with RTCA Refrigeration System and Control Components

- | | | |
|---|--|---|
| 1. Discharge Service Valve | 10. Liquid Line Service Valve | 19. Temperature Responsive Valve |
| 2. Oil Separator | (Backseat Port Upstream) | 20. Entering Water Connection |
| 3. 1/4" Angle Valve | 11. Filter/Dryer | 21. Evaporator Entering Water Temperature Sensor |
| 4. Oil Cooler (if "V" is in 17th digit of Model #) | 12. Sight Glass | 22. Relief Valve |
| 5. Oil Line Service Valve | 13. Schrader Valve | 23. Suction Service Valve |
| 6. Oil Temperature Sensor | 14. Electronic Expansion Valve | 24. Compressor Suction Refrigerant Temperature Sensor |
| 7. Condenser | 15. 1/4" Angle Valve | 25. Low Pressure Switch |
| 8. Saturated Condenser Refrigerant Temperature Sensor | 16. Saturated Condenser Refrigerant Temperature Sensor | |
| 9. Solenoid Valve | 17. Leaving Water Connection | |
| | 18. Evaporator Leaving Water Temperature Sensor | |
- NOTE: - - - Field Installed Piping
 — Factory Installed Piping*

Refrigeration (Cooling) Cycle

RTWA Cycle Description

Figure 35 represents the refrigeration system and control components of an RTWA. Vaporized refrigerant leaves the evaporator and is drawn into the compressor. Here it is compressed and leaves the compressor as a mixture of hot gas and oil (which was injected during the compression cycle).

The mixture enters the oil separator at the in/out cap. The separated oil flows to the bottom of the separator, while the refrigerant gas flows out the top and passes on to the tubes in the condenser. Water flows through the copper tubes in the condenser, which removes the heat from the refrigerant and condenses it.

The condensed refrigerant passes through the electronic expansion valve and into the tubes of the evaporator. As the refrigerant vaporizes, it cools the system water that surrounds the tubes in the evaporator.

Operating Principles

RTUA With RTCA Cycle Description

Figure 36 represents the refrigeration system and control components in a system comprised of an RTUA and an RTCA. Vaporized refrigerant leaves the evaporator and is drawn into the compressor. Here it is compressed and leaves the compressor as a mixture of hot gas and oil (which was injected during the compression cycle).

The mixture enters the oil separator at the in/out cap. The separated oil flows to the bottom of the separator, while the refrigerant gas flows out the top and passes through the tubes in the condenser. Air flows over the coils in the condenser, which remove the heat from the refrigerant and condenses it.

The condensed refrigerant passes through the electronic expansion valve and into the tubes of the evaporator. As the refrigerant vaporizes, it cools the system water that surrounds the tubes in the evaporator.

Compressor Description

The compressors used by the Model RTWA and RTUA Series "R" Water-cooled chiller consists of two distinct components: the motor and the rotors.

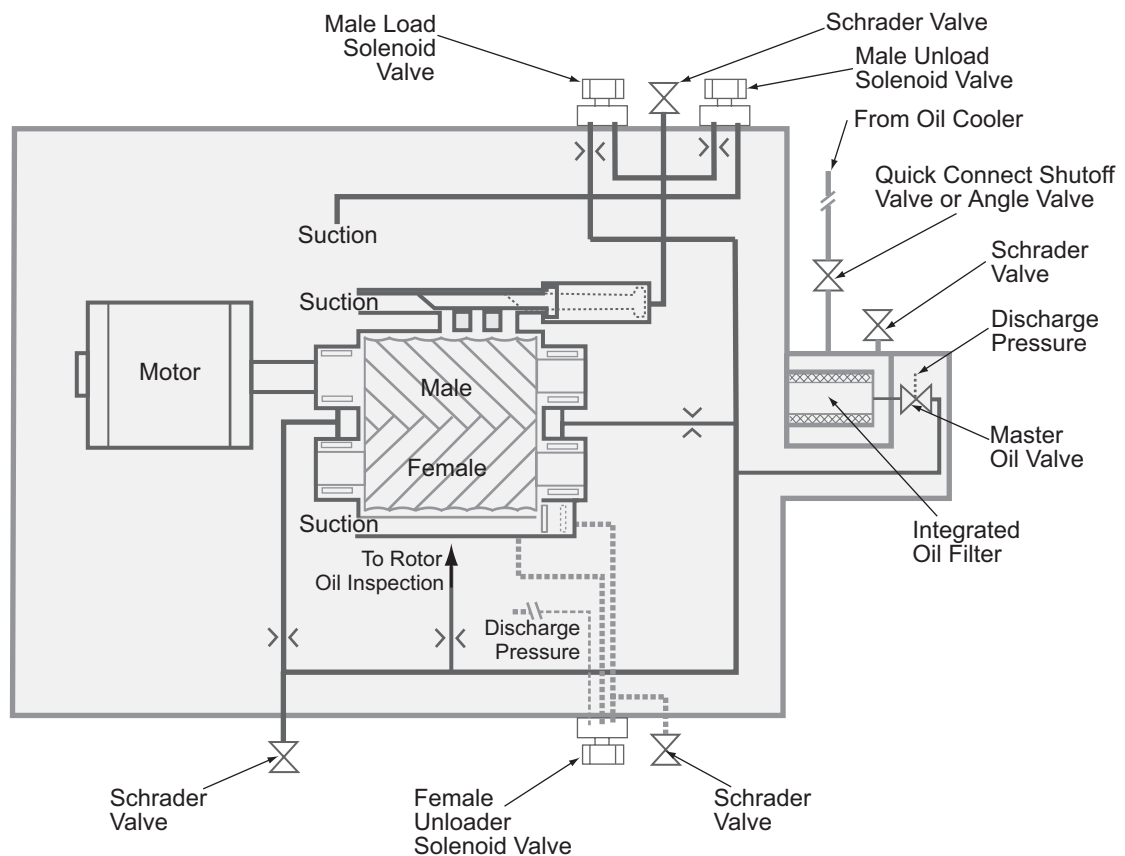

Figure 37 RTWA Refrigerant and Oil Diagram

Compressor Motor

A two-pole, hermetic, squirrel-cage induction motor (3600 rpm) directly drives the compressor rotors. The motor is cooled by suction refrigerant gas from the evaporator, entering the end of the motor housing through the suction line.



Operating Principles

Compressor Rotors

The compressor is a semi-hermetic, direct-drive helical rotary type compressor. Each compressor has two rotors - "male" and "female" - which provide compression. See [Figure 37](#). The male rotor is attached to, and driven by, the motor, and the female rotor is, in turn, driven by the male rotor. Separately housed bearing sets are provided at each end of both rotors.

The helical rotary compressor is a positive displacement device. The refrigerant from the evaporator is drawn into the suction opening at the end of the motor barrel, through a suction strainer screen, across the motor, and into the intake of the compressor rotor section. The gas is then compressed and discharged directly into the discharge line.

There is no physical contact between the rotors and compressor housing. The rotors contact each other at the point where the driving action between the male and female rotors occurs. Oil is injected along the top of the compressor rotor section, coating both rotors and the compressor housing interior. Although this oil does provide rotor lubrication, its primary purpose is to seal the clearance spaces between the rotors and compressor housing.

A positive seal between these internal parts enhances compressor efficiency by limiting leakage between the high pressure and low pressure cavities.

Capacity control is accomplished by means of two unloader valve assemblies in the rotor section of the compressor. The female rotor valve is a two-position valve and the male valve is an infinitely variable position valve. See [Figure 37](#).

Compressor load capacity is dictated by the positions of the unloader valves. They divert refrigerant gas from the rotors to the compressor suction, thus unloading the compressor. This varies the compressor capacity to match the load and reduces the KW draw of the compressor motor.

The two-position female unloader will fully open or fully close a port on the rotor housing, at the discharge end of the female rotor. This relieves a refrigerant gas to suction and unloads the compressor. The female unloader valve is the first stage of loading after the compressor starts and the last stage of unloading before the compressor shuts down.

The modulating male unloader valve opens or closes ports in the rotor housing along the side of the male rotor. It can move to a more loaded (closed) position after the female unloader valve is in the loaded position or can relieve refrigerant gas to suction to unload the compressor.

Compressor Loading Sequence (RTWA and RTUA only)

When there is a call for chilled water, the UCM will start the compressor which has the least number of starts. If the first compressor cannot satisfy the demand, the UCM will start the other compressor and then balance the load on both compressors by pulsing the load/unload solenoids.

The load on the compressors will be kept in balance, as load fluctuates, until the demand for chilled water is reduced to a level that can be handled by one compressor. At this time, the UCM will drop off the compressor that has the greatest number of operating hours and will adjust the load on the other compressor, as required.

Oil System Operation (RTWA and RTUA Only)

Overview

Oil that collects in the bottom of the oil separator is at condensing pressure during compressor operation; therefore, oil is constantly moving to lower pressure areas. Refer to [Figure 37](#).



Operating Principles

As the oil leaves the separator, it passes through the oil cooler. It then goes through the service valve and filter. At this point it travels through the master oil valve. Then it splits to feed the male load/unload solenoid valves and to provide oil injection and bearing lubrication.

If the compressor stops for any reason, the master oil valve closes, isolating the oil charge in the separator and oil cooler during "off" periods. The master oil valve is a pressure activated valve. Discharge pressure off the rotors, that is developed when the compressor is on, causes the valve to open.

Oil Separator

The oil separator consists of a vertical tube, joined at the top by the refrigerant discharge line from the compressor. This causes the refrigerant to swirl in the tube and throws the oil to the outside, where it collects on the walls and flows to the bottom. The compressed refrigerant vapor, stripped of oil droplets, exits out the top of the oil separator and is discharged into the condenser.

Compressor Bearing Oil Supply

Oil is injected into the bearing housings located at each end of both the male and female rotors. Each bearing housing is vented to compressor suction, so that oil leaving the bearings returns through the compressor rotors to the oil separator.

Compressor Rotor Oil Supply

Oil flows through this circuit directly from the master oil filter, through the master oil valve to the top of the compressor rotor housing. There it is injected along the top of the rotors to seal clearance spaces between the rotors and the compressor housing and to lubricate the rotors.

Female Unloader Valve

The position of the female unloader valve determines compressor capacity. Its position is dependent on whether the backside of the female unloader valve is exposed to the compressor discharge or suction pressure. See [Figure 37](#).

The female unloader valve receive a constant signal from the UCM, based on system cooling requirements. To load the compressor, the female unloader valve is energized and discharge pressure is passed through the normally-closed port and into the cylinder. This pushed the female unloader valve closed.

To unload the compressor, the female unloader valve solenoid is de-energized and the discharge pressure is relieved to the suction of the compressor. The female unloader valve retracts into the cylinder and the compressor is unloaded.

Just prior to a normal compressor shutdown, the male unload valve solenoid is energized and the slide valve moves to the fully-unloaded position, so the unit always starts fully unloaded.

Oil Filter

Each compressor is equipped with a replaceable element oil filter. The filter removes any impurities that could foul the solenoid valve orifices and compressor internal oil supply galleries. This also prevents excessive wear of compressor rotor and bearing surfaces. Refer to the maintenance portion of this manual for recommended filter element replacement intervals.

RTCA Condenser Fan Staging

The fans on the RTCA 70-125 Ton units are staged by logic in the UCM of the RTUA. The UCM takes several different pressures and temperatures into account, to determine when fans should be added or subtracted. Input from

Operating Principles

the outside air temperature sensor, the saturated condensing refrigerant temperature sensor, and the saturated evaporator refrigerant temperature sensor are monitored to determine fan staging.

The number of fans activated at startup is dependant upon the outdoor air temperature. [Figure 38](#) shows fan activation at different temperatures.

During normal operation, the micro uses PID control to maintain a 70 ± 5 psid between the condensing pressure and the evaporator pressure. Through the use of algorithm logic, a fan will be added if the pressure differential is greater than 75 psid and the fan inverter is at maximum speed.

A "Low Differential Pressure" diagnostic will take the circuit off-line if the pressure differential falls below 40 psid for more than two minutes.

A "High Differential Pressure" diagnostic will take the circuit off-line if the pressure differential increases to 350 psid or greater. This diagnostic can also be produced if the pressure differential increases to the range between 320 psid and 349 psid. The UCM will allow the unit to remain on-line if there is no increase in pressure for a one hour period. Otherwise, the unit will trip off-line and display the "High Differential Pressure" diagnostic.

Table 24 Standard RTCA Fan Configuration

Circuit #1 = Right side facing control panel.

Circuit #2 = Left side facing control panel.

Tons	Circuit #1	Circuit #2
70	4	4
80	4	4
90	4	4
100	5	5
110	5	5
125	5	5

Note: Closest fan to the control panel on each circuit is controlled with the optional fan inverter.

Operating Principles

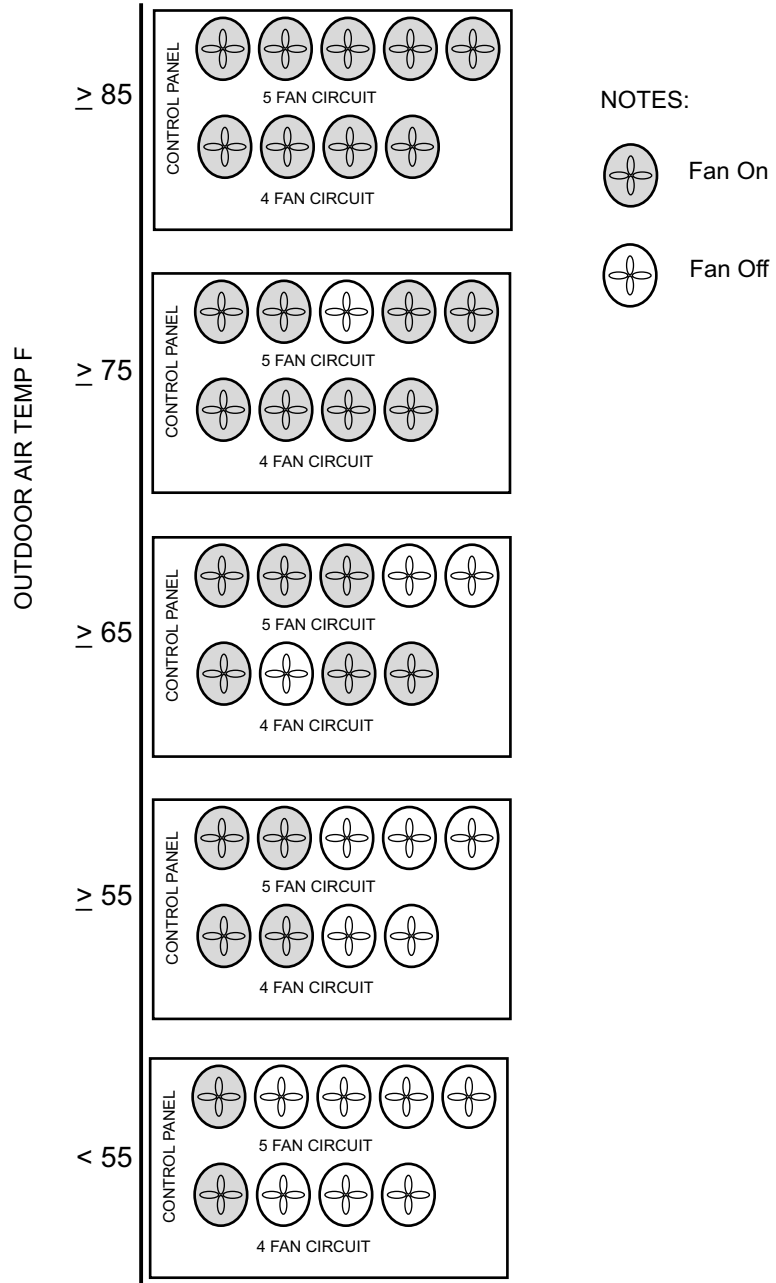

Figure 38 Fan Staging for RTCA 70 to 125

Controls Interface

The exclusive Trane Adaptive Control logic with the Clear Language Display is comprised of a system of individual modules located in the control panel of the RTWA and RTUA units. The system consists of six different microprocessor-based components, one of which is the Clear Language Display and The processors are:

- Clear Language Display 1U6
- Chiller Module 1U1
- Communication and Setpoint Reset Option Module 1U2
- Expansion Valve Module 1U3
- Compressor Module (one per compressor) 1U4, 1U5
- Remote Display Buffer Option Module 1U7
- LCI-C Option Module 1U8

The Clear Language Display has various functions that allow the operator to read unit information and adjust setpoints. The following is a list of the available functions:

- Operating and Diagnostic descriptions
- Settings of local setpoints and adjustments
- Actual controlling setpoints
- Specific temperatures
- Specific Pressures
- Enable/Disable status of features and options
- Selection status of SI units or English units
- Under/Over voltage protection
- Display of % line voltage
- Alarm/Running/Maximum Capacity contacts
- Display Starts and Hours

Clear Language Display Keypad Overview

Local operator interface with the system is accomplished using the 16 keys on the front of the Clear Language Display panel. The readout screen is a two line, 40 character liquid crystal with a backlight. The backlight allows the operator to read the display in low-light conditions. The depression of any key will activate the backlight. The backlight will stay activated for 10 minutes after the last key is pressed. At 10 F ambient or colder, the backlight will stay activated continuously.

The keys are grouped on the keyboard by the following functions (refer to Figure 39):

- Selected Group Report
- Selected Setpoint Report
- Selection Keys
- Stop & Auto Keys

Controls Interface



Figure 39 Operator Interface Adaptive Control

Selected Group Report

This group of four keys allows the operator to select and view the following reports:

- Custom Report
- Chiller Report
- Refrigerant Report
- Compressor Report

The Custom Report is the only report of the four that is defined by the operator. Any display under the other three reports can be added to the Custom Report by pressing the plus Δ key while the desired read-out is on the display. A maximum of 20 entries can be contained under the Custom Report. Items can be deleted from the Custom Report by pressing the minus ∇ key when the desired read-out is on the display. The operator must be in the Custom Report menu to delete the desired item.

The Chiller Report, Refrigerant Report and Compressor Report are informational reports that give current status. Each report and its contents are discussed in detail on the following pages.

When any of the four report keys are pressed, the first readout on the display will be the header. The header identifies the title of the report and summarizes the items in the report.

The Next key and Previous key allow the operator to scroll up and down through the display items listed under the report displays. When the last item of a report is displayed and the Next key is pressed, the display will wrap



Controls Interface

around to the header of the report. When the first item of a report is displayed and the Previous key is pressed, the display will wrap around to the last item.

Selected Setpoint Report

The first three keys on the second row - Operator Settings, Service Settings and Service Tests - allow the operator to adjust various setpoints and perform various tests. Certain items in these groups are password protected. Refer to the Password section for additional information.

When a setpoint key is press, a header will be displayed. The setpoint headers identify the available items and setpoint functions.

The Next and Previous keys function in the same manner as that describe in Selected Report Group, above.

Setpoint values are incremented by pressing the plus Δ key and decremented by pressing the Minus ∇ key. Once a setpoint is changed, the Enter key must be pressed to save the new setpoint. If the Cancel key is pressed, the setpoint value on the display will be ignored and the original setpoint will remain.

Passwords

Passwords are needed to enter into the Service Setup Menu and the Machine Configuration Menu. Both of these menus are accessed through the Service Settings key. If access into these menus is necessary, follow the list of steps below:

1. Press Service Settings.
2. Press Next until the readout in the display is:
Password Required For Further Access
"Please enter Password"
3. To enter into the Service Setup Menu, press:
 $\Delta \Delta \nabla \nabla \Delta \Delta$ Enter
4. To enter into the Machine Configuration Menu, press:
 $\Delta \nabla \Delta \nabla \Delta \nabla$ Enter

Select Report Group and Select Settings Group Flowcharts

The first block of the flowchart is the header which is shown on the display after the menu key is pressed. For example:

Press Chiller Report and the readout on the display will be:

CHILLER RPRT:STATUS, WTR TEMPS & SETPTS
"PRESS (NEXT) (PREVIOUS) TO CONTINUE"

Press Next to move down through the Chiller Report. As shown in the figures, the flowchart explains the conditions that the UCM looks at to determine which readout is to be displayed next. For example:

Press Chiller Report to display the header Press Next to display
MODE: OPERATING MODE]
REQUESTED SETPOINT SOURCE: [SETPT SOURCE]

Press Next to display

COMPRESSOR ON
CIRCUITS LOCKED OUT

Press Next to display



Controls Interface

ACTIVE ICE TERMINATION SETPOINT

Or

ACTIVE CHILLED WATER SETPOINT

The UCM will determine which screen will be displayed after looking at the current Operating Mode. If the Operating Mode is "Ice Making" or "Ice Making Complete", ACTIVE ICE TERMINATION SETPOINT will be displayed. Otherwise, ACTIVE CHILLED WATER SETPOINT will be shown.

The flowcharts also list the setpoint ranges, default options and a brief description of the item, when necessary. This information is shown in the lefthand column of the page, adjacent to the appropriate display.

NOTE: The default values listed on the flowcharts are the values used on service replacement modules. Factory and field settings will differ from the default values and must be adjusted as necessary.

Auto/Stop Keys

The chiller will go through a "STOPPING" mode when the Stop key is pressed if a compressor is running. This key has a red background color surrounding it, to distinguish it from the others.

If the chiller is in the Stop mode, pressing the Auto key will cause the UCM to go into the Auto/Local or Auto/Remote mode, depending on the Setpoint Source setting. The Auto key has a green background color.

When either the Auto or Stop key is pressed, Chiller Operating Mode (Chiller Report Menu) will be shown on the display.

Power Up

When power is first applied to the control panel, the Clear Language Display goes through a self-test. For approximately five seconds, the readout on the display will be:

SELF TEST IN PROGRESS

During the self-test, the backlight will not be energized. When the tests are successfully complete, the readout on the display will be

6200 xxxx-xx [TYPE] configuration

Updating Unit Data, Please Wait

When updating is successfully completed, the system will default to the first display after the Chiller Report header:

MODE: OPERATING MODE]

REQUESTED SETPOINT SOURCE: [SETPT SOURCE]

and the backlight will be activated.

Controls Interface

[OPERATING MODE]

- Reset
- Stopped by Local Display
- Stopped by Remote Display
- Stopped by Tracer
- Stopped by Ext Source
- Auto
- Waiting, Restart Inhibit
- Starting
- Running
- Running, Current Limit
- Running, Condenser Limit
- Running, Evaporator Limit
- Stopping
- Making Ice
- Ice Making Complete
- Low Ambient Temp Lockout
- EXV Test
- Manufacturing Test
- Service Pumpdown

[SETPT SOURCE]

- Local
- Tracer

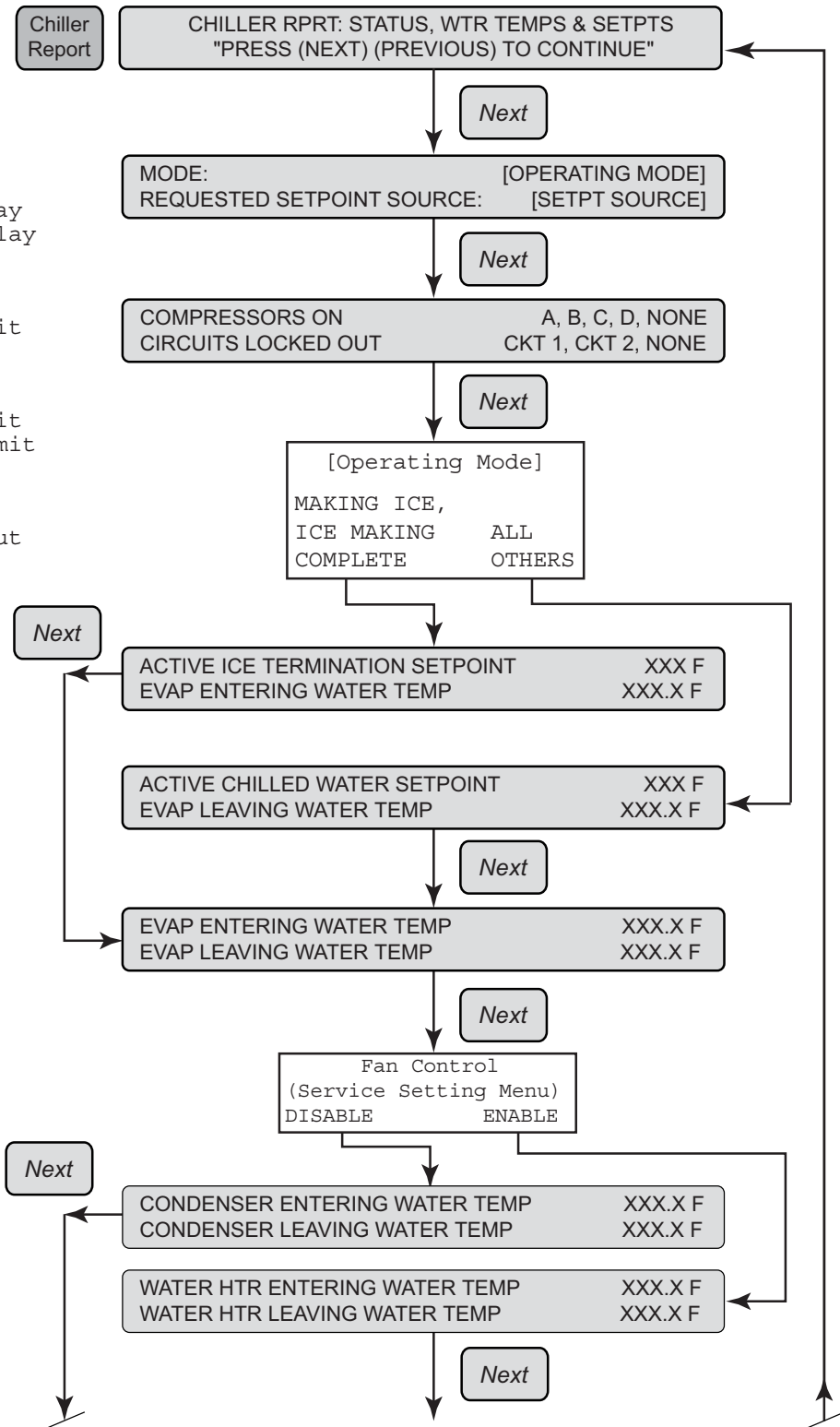

To ACTIVE CURRENT LIMIT SETPOINT on next page.



Controls Interface

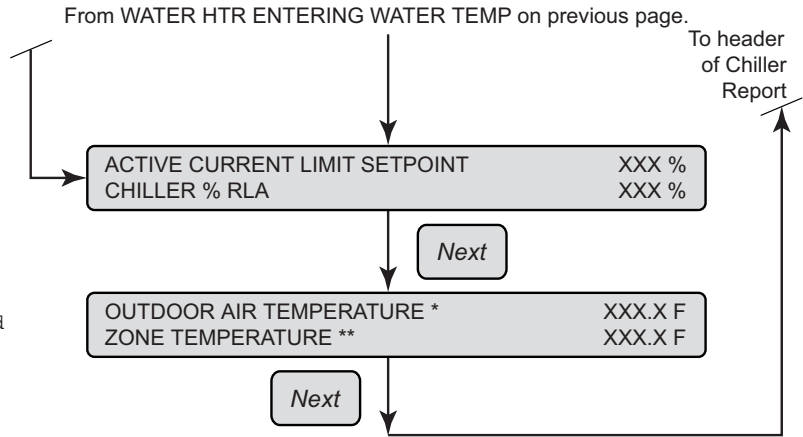

* Dashes will be displayed if the sensor is open or shorted and neither Outdoor Air Reset or Low Ambient Lockout is enabled.

* Dashes will be displayed if the Zone Temp. Sensor is open or shorted and Zone Reset is not enabled.

**Not applical on domestic units.

Controls Interface

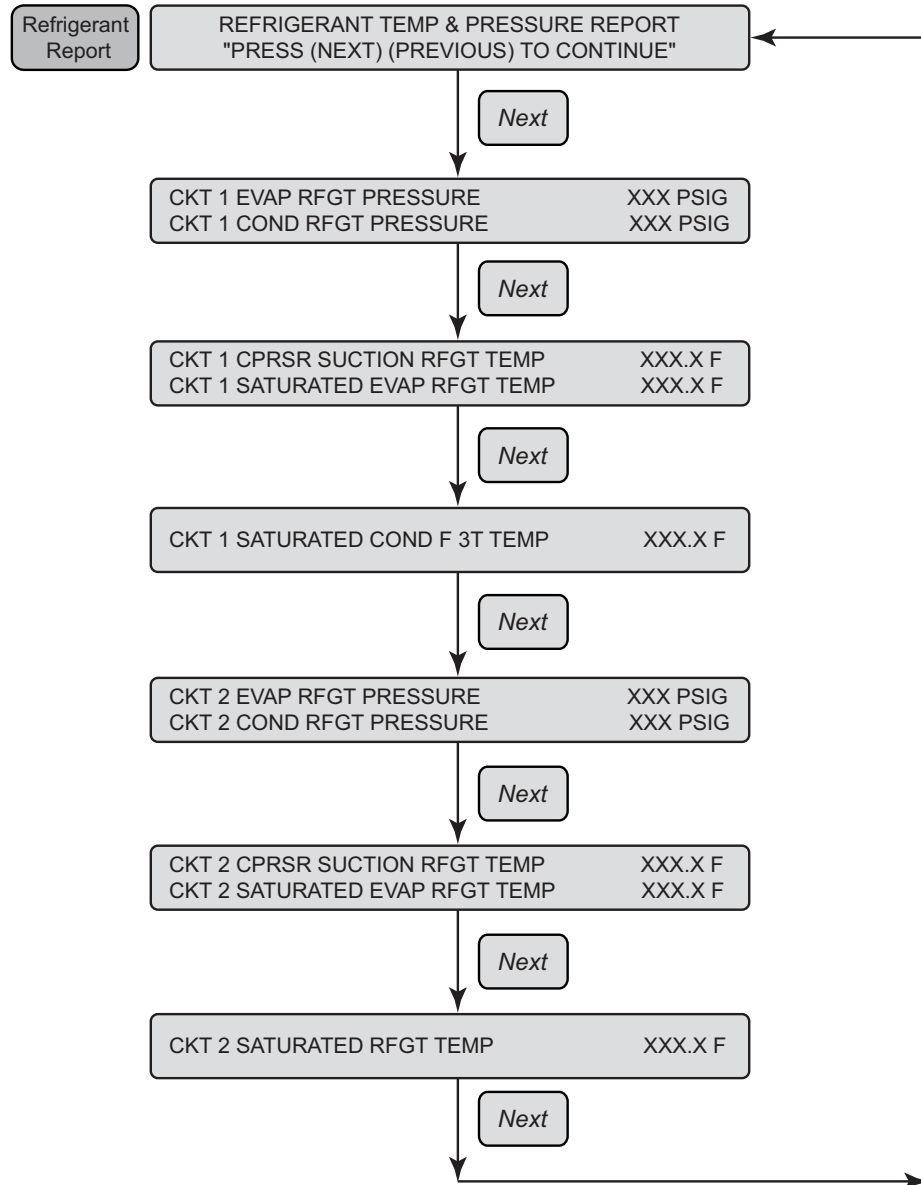



Controls Interface

* Display will change according to comp. reviewing
 COMPRESSOR A MODE
 COMPRESSOR B MODE
 COMPRESSOR C MODE
 COMPRESSOR D MODE

[MODE]
 Stopped
 Locked Out
 Waiting for Restart Inhibit Time
 Starting
 Running
 Run - Condenser Limit
 Run - Evaporator Limit
 Run - Current Limit
 Stopping
 Service Pumpdown

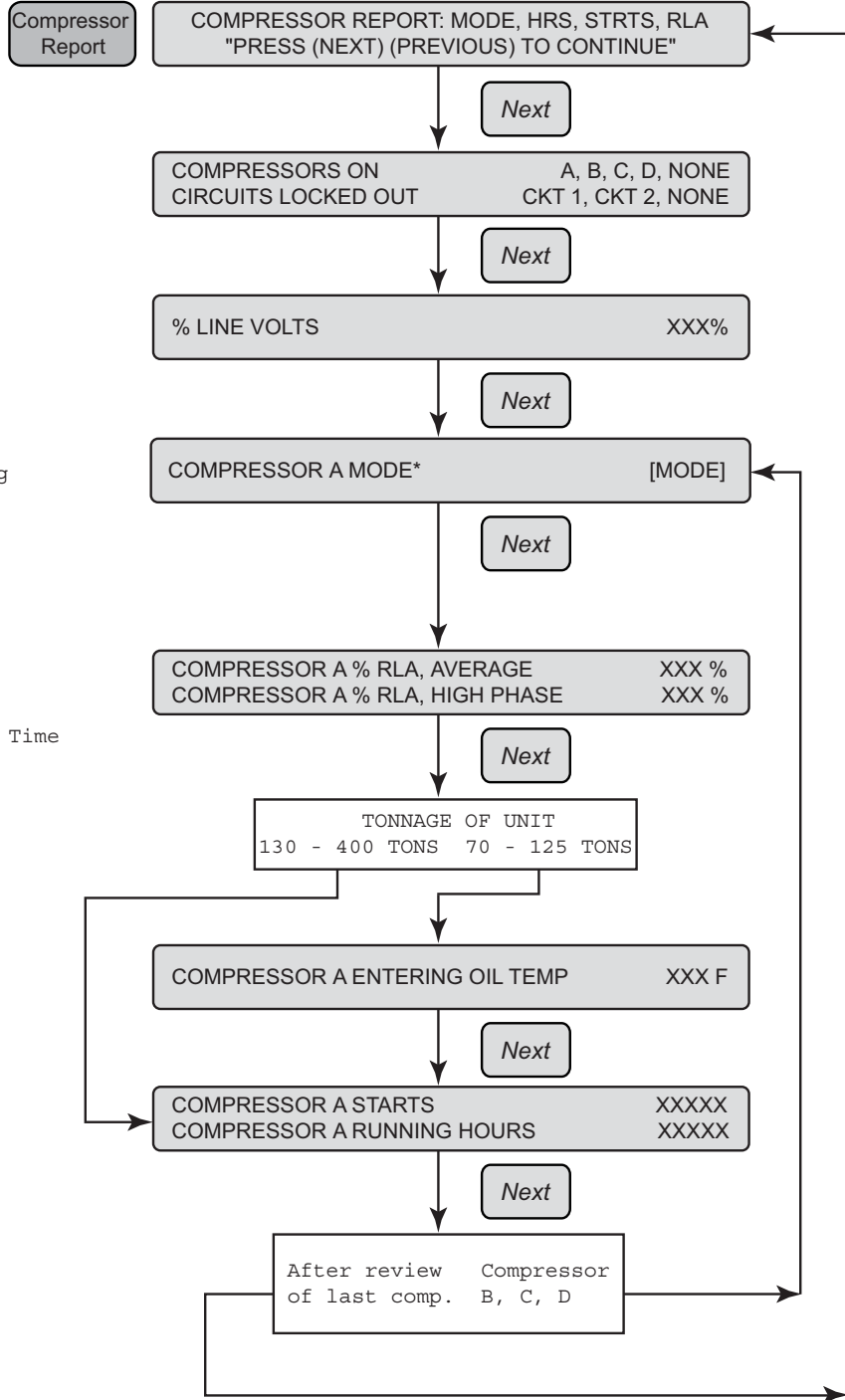

Controls Interface

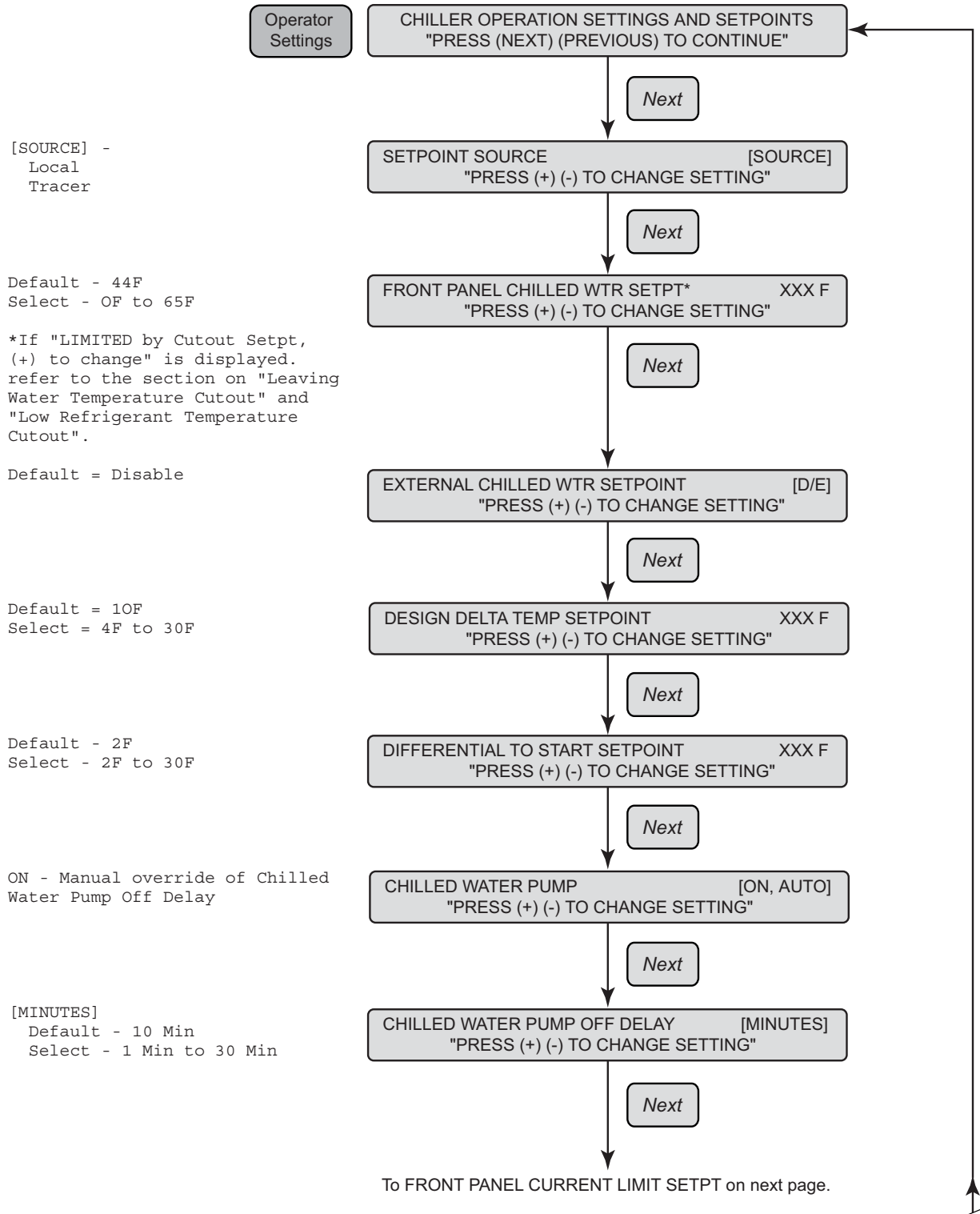

[SOURCE] -
Local
Tracer

Default - 44F
Select - 0F to 65F

*If "LIMITED by Cutout Setpt,
(+) to change" is displayed.
refer to the section on "Leaving
Water Temperature Cutout" and
"Low Refrigerant Temperature
Cutout".

Default = Disable

Default = 10F
Select = 4F to 30F

Default - 2F
Select - 2F to 30F

ON - Manual override of Chilled
Water Pump Off Delay

[MINUTES]
Default - 10 Min
Select - 1 Min to 30 Min



Controls Interface

From CHILLED WATER PUMP OFF DELAY on previous page.

Default = 120%
Select = 40% to 120%

FRONT PANEL CURRENT LIMIT SETPT XXX %
"PRESS (+) (-) TO CHANGE SETTING"

Next

Default = Disable

EXTERNAL CURRENT LIMIT SETPT [D/E]
"PRESS (+) (-) TO CHANGE SETTING"

Next

Default = Disable

LOW AMBIENT LOCKOUT [D/E]
"PRESS (+) (-) TO CHANGE SETTING"

Next

LOW AMBIENT LOCKOUT
(Operator settings menu)
ENABLE DISABLE

Default = 20F
Select = -20F to 60F

LOW AMBIENT LOCKOUT SETPOINT XXX F
"PRESS (+) (-) TO CHANGE SETTING"

Next

Default = Disable
Select = Return Wtr
Zone
Outdoor Air

CHILLED WATER RESET TYPE [TYPE]
"PRESS (+) (-) TO CHANGE SETTING"

Next

Type of Chilled Water
Reset Selected Above
RETURN WATER
ZONE
OUTDOOR AIR DISABLE

[TYPE]
Return:
Default = 50%
Range = 10% to 120%
Zone:
Default = 100%
Range = 50% to 300%
Outdoor
Default = 10%
Range = -80% to 80%

[TYPE] TYPE, RESET RATIO XXX %
"PRESS (+) (-) TO CHANGE SETTING"

Next

To [TYPE] TYPE, START RESET SETPT on next page.

Controls Interface

From [TYPE] TYPE, RESET RATIO on previous page.

[TYPE]
 Return:
 Default = 10F
 Range = 4F to 30F
 Zone:
 Default = 78F
 Range = 55F to 85F
 Outdoor:
 Default = 90F
 Range = 50F to 130F

[TYPE]
 Return:
 Default = 5F
 Range = 0F to 20F
 Zone:
 Default = 5F
 Range = 0F to 20F
 Outdoor:
 Default = 5F
 Range = 0F to 20F
 Default = Disable

Default = 27F
 Select = 20F to 31F

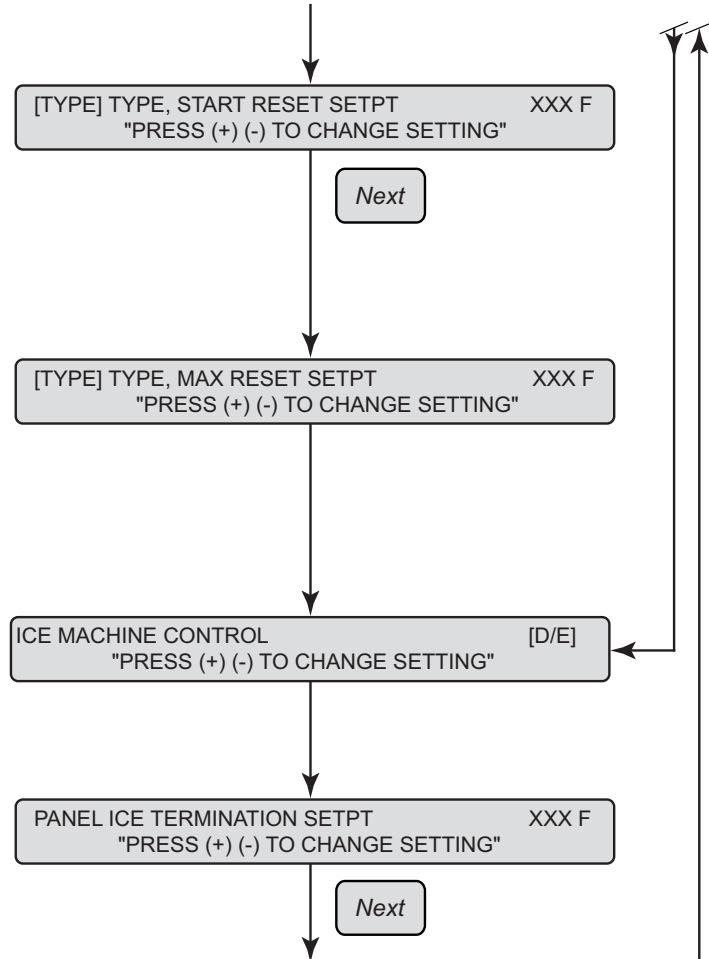



Controls Interface

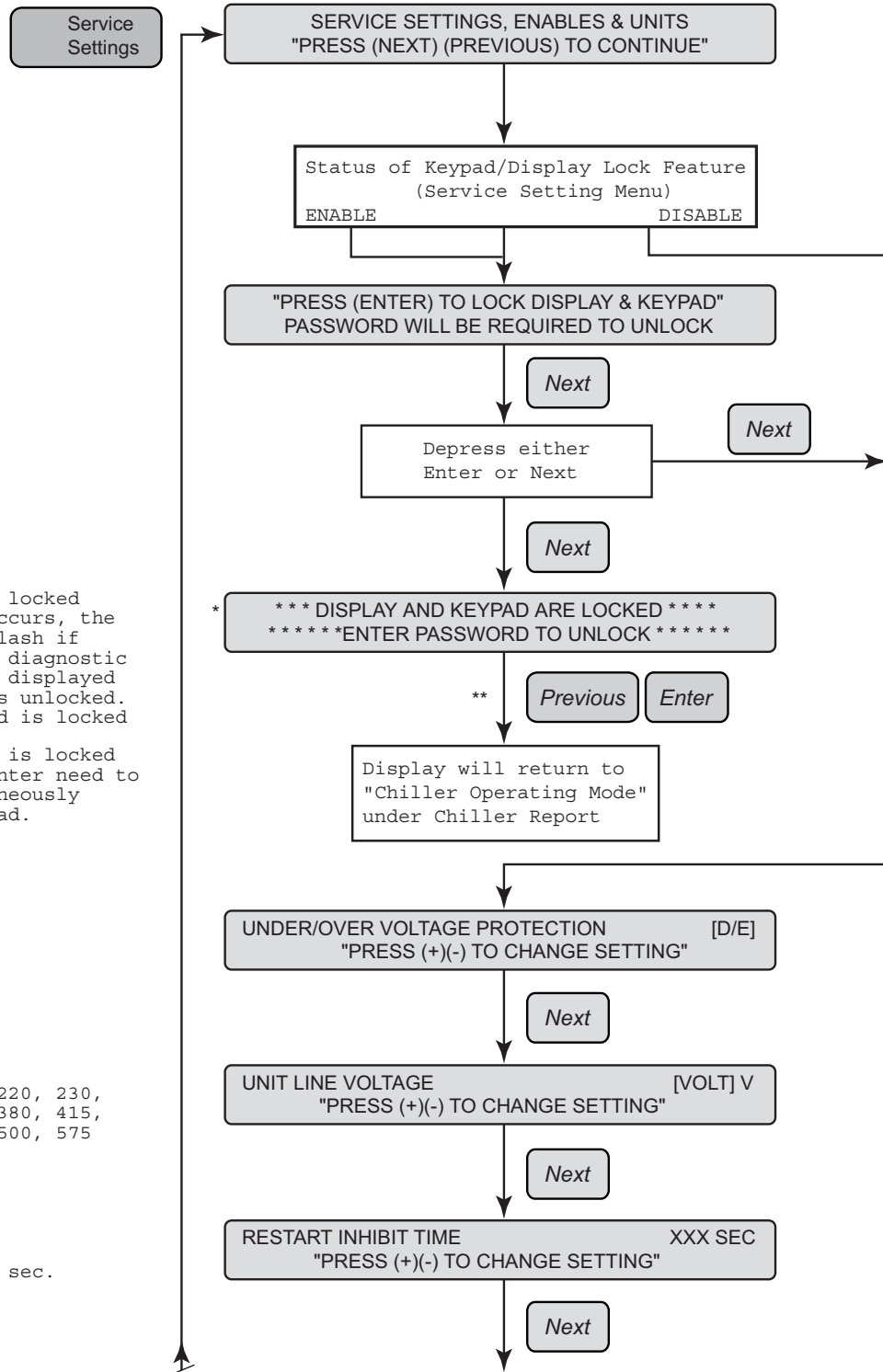

* If the keypad is locked and a diagnostic occurs, the alarm light will flash if applicable but the diagnostic screen will not be displayed until the keypad is unlocked.
 * * Once the keypad is locked

** Once the keypad is locked the Previous and Enter need to be pressed simultaneously to unlock the keypad.

Default = Disable

Default = 460
 Selections = 200, 220, 230,
 346, 380, 415,
 460, 500, 575
 400

Default = 120 sec.
 Select = 30 to 120 sec.

To BALANCED CPRSR STARTS & HOURS on next page.

Controls Interface

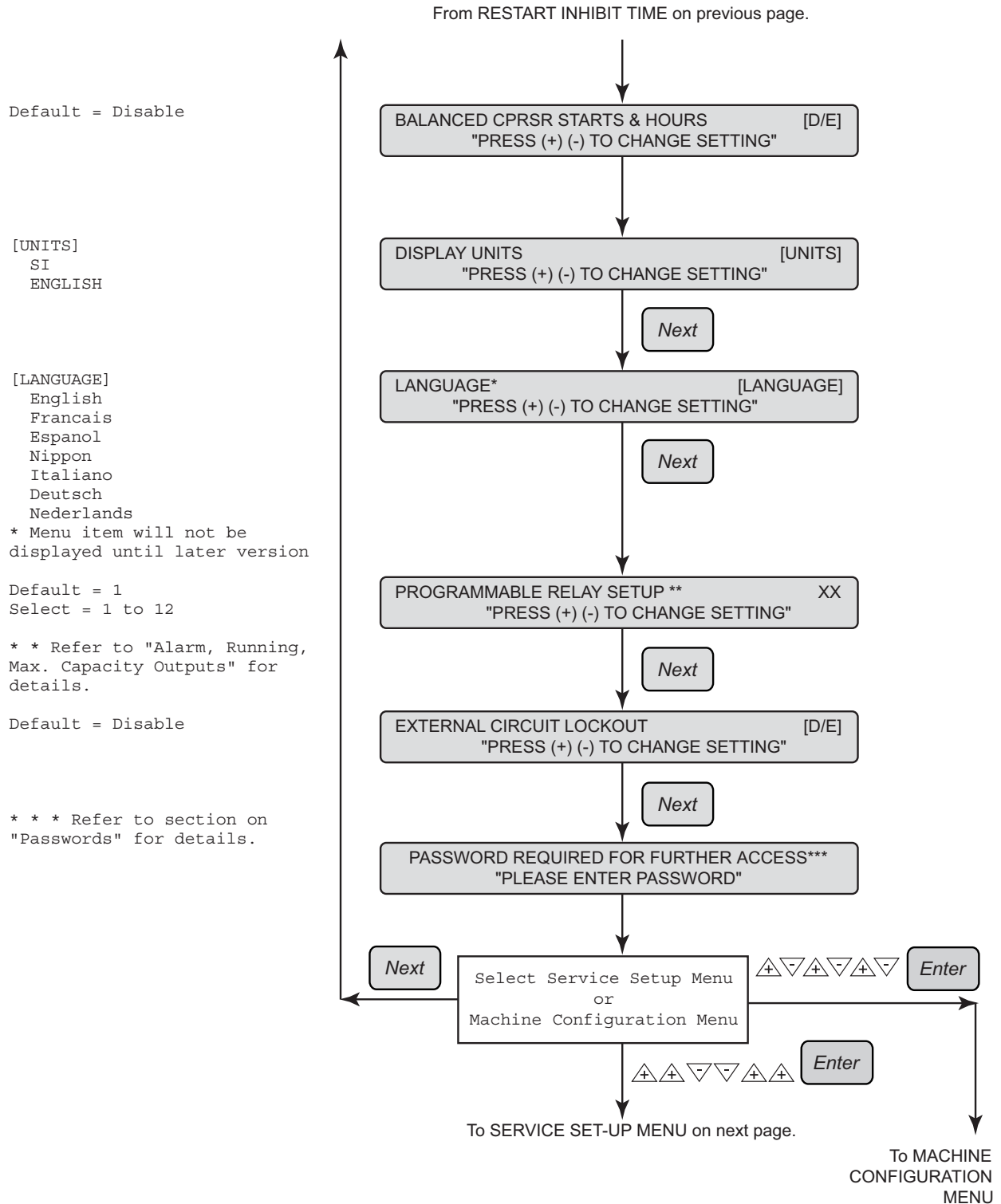



Controls Interface

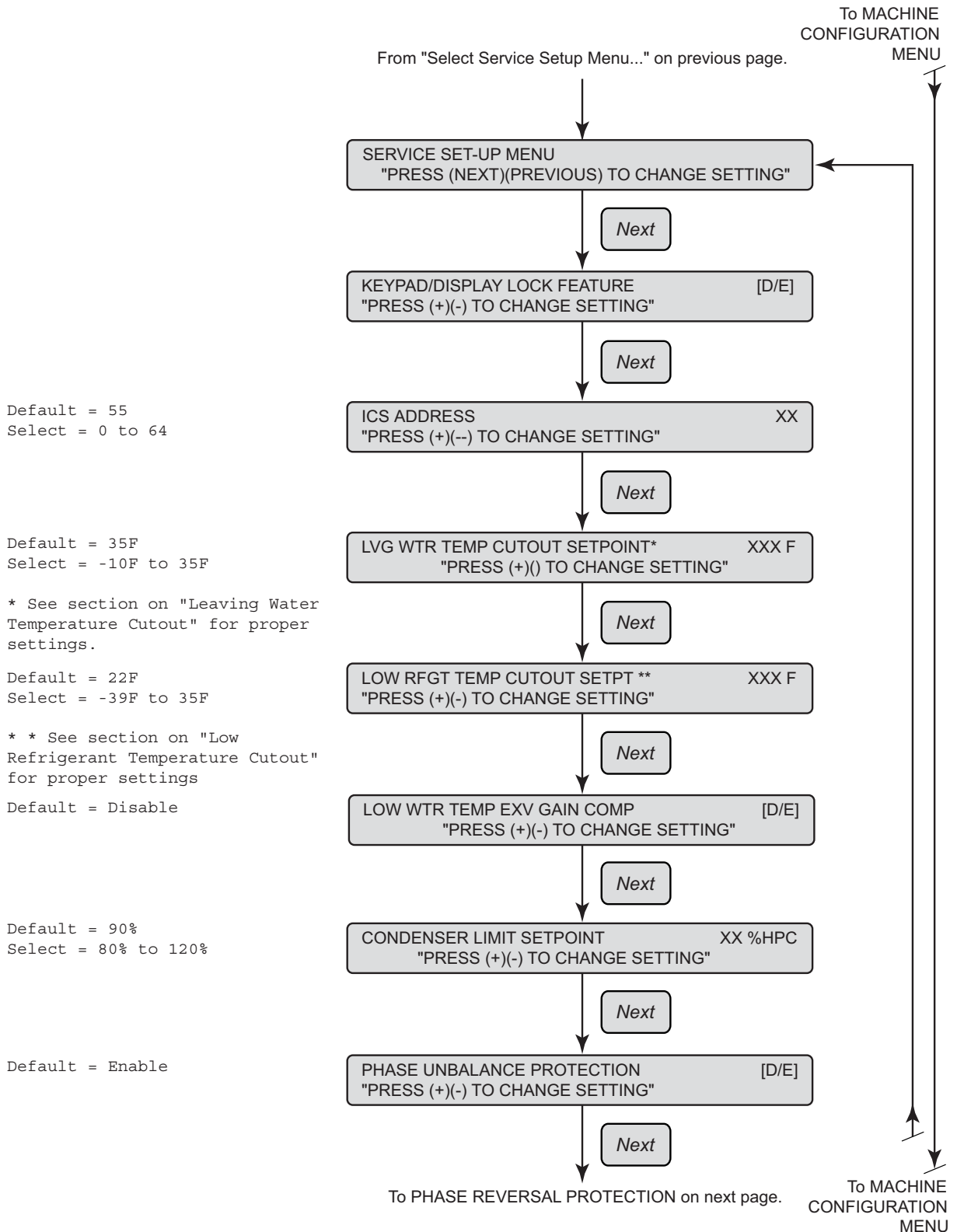

Controls Interface

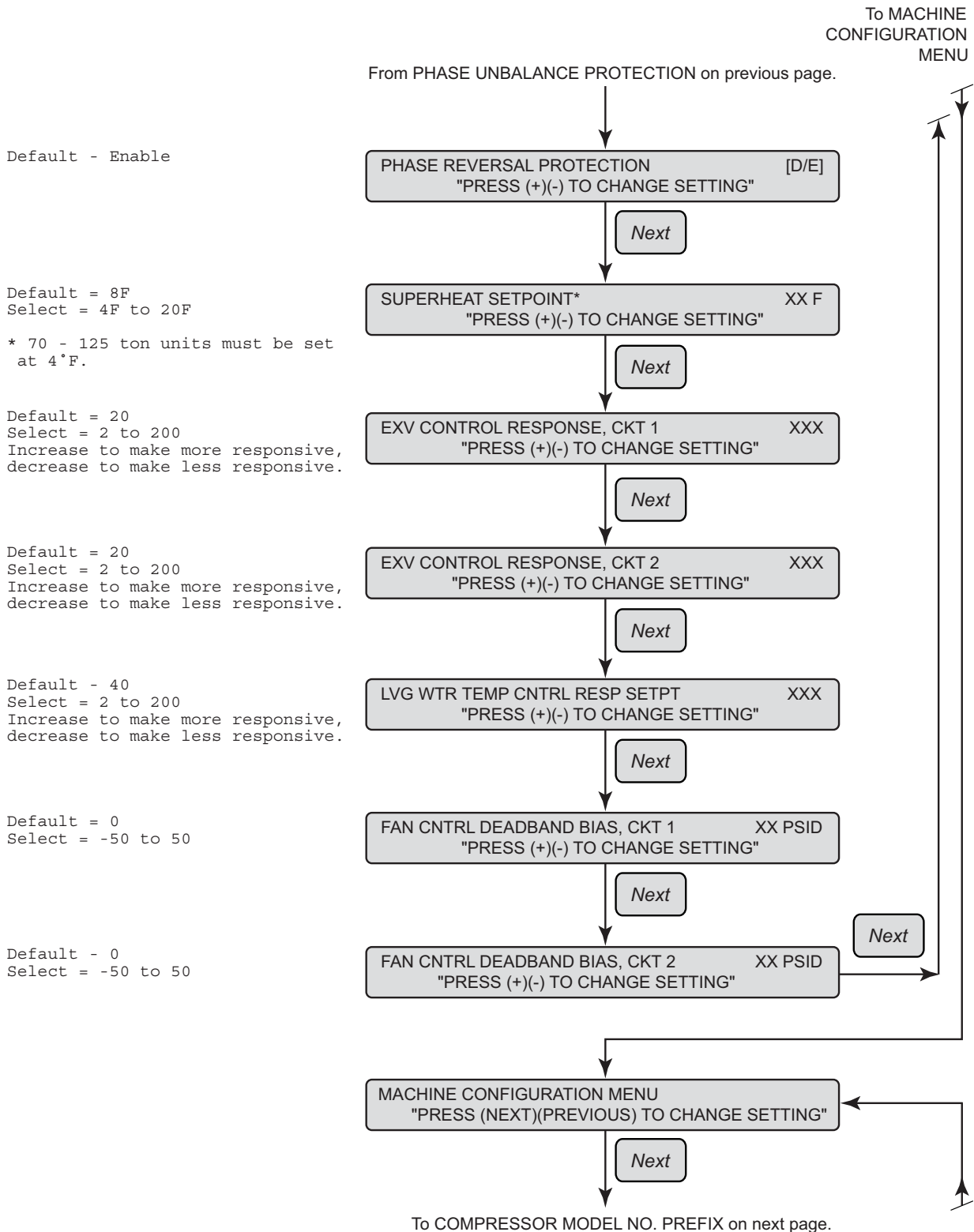



Controls Interface

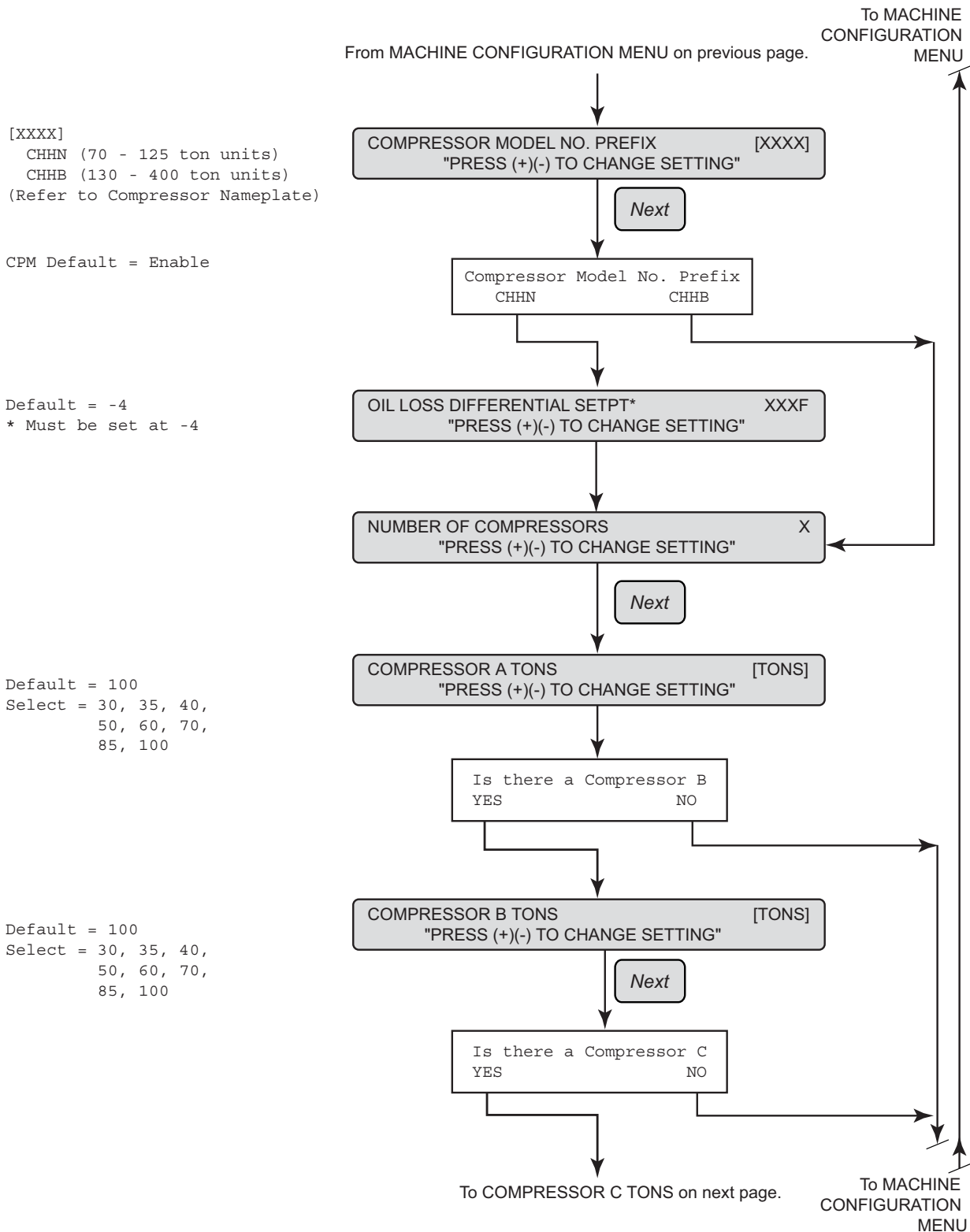



Controls Interface

Default = 100
 Select = 30, 35, 40,
 50, 60, 70,
 85, 100

Default = 100
 Select = 30, 35, 40,
 50, 60, 70,
 85, 100

Default = RTA
 Select = RTA, RTW, RTU

Default = Disable
 * If Variable Speed Fan is set to Enable for either Circuit 1 or Circuit 2, then 'Low Ambient Unit, Half Air Flow Fan' and 'Low Ambient Unit, Two Speed Motor' are forced to Disable.
 Default = Disable

Default = 7
 Select = 4, 5, 6, 7, 8,
 10, 12, 14

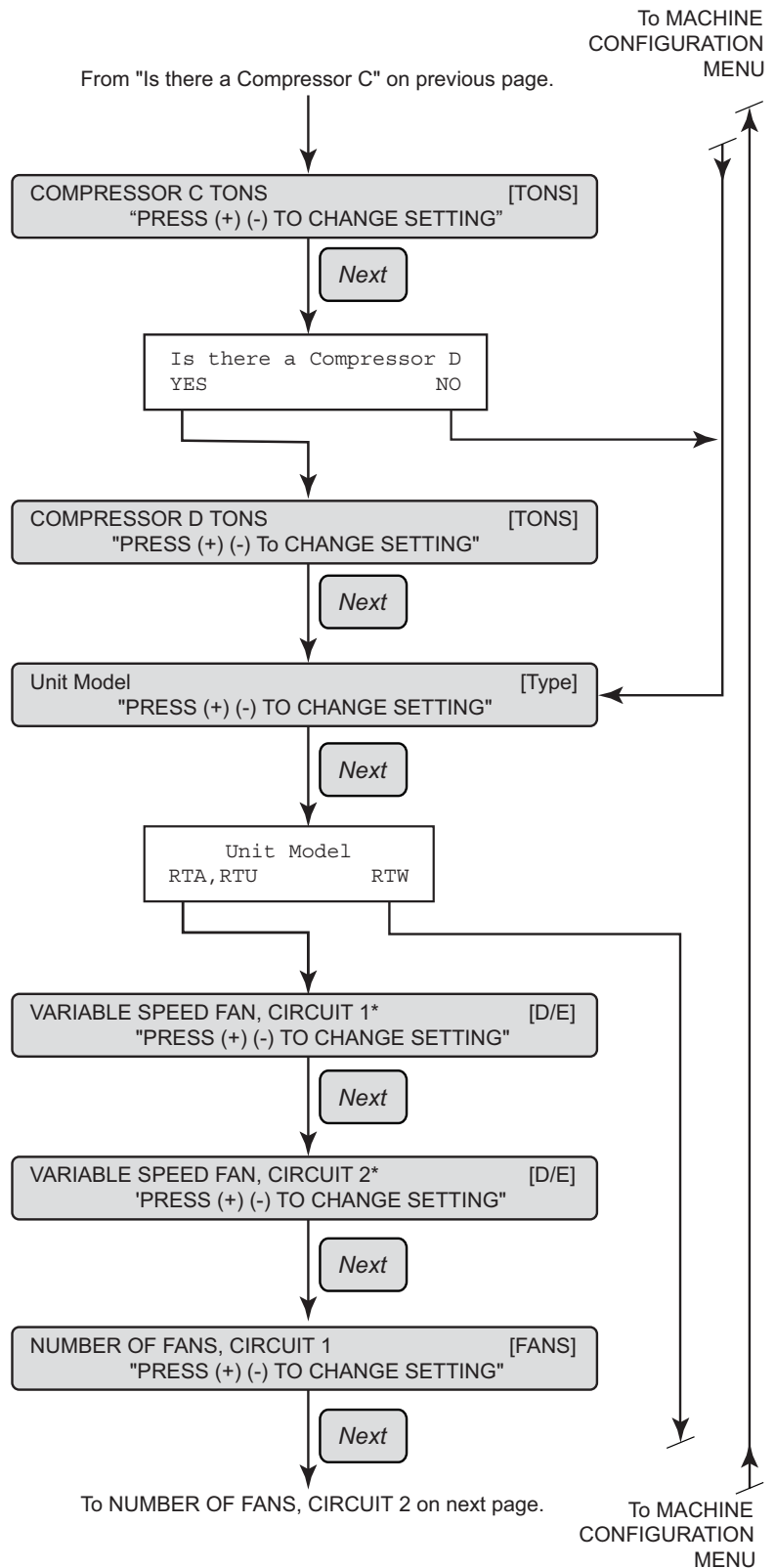



Controls Interface

Default = 7
 Select = 4, 5, 6, 7, 8,
 10, 12, 14

Default = Disable

Default = Y Delta
 Select - Y Delta,
 Part Winding

Default = 00
 Select = 00 to 31

Default = 00
 Select = 00 to 31

Default = 00
 Select = 00 to 31

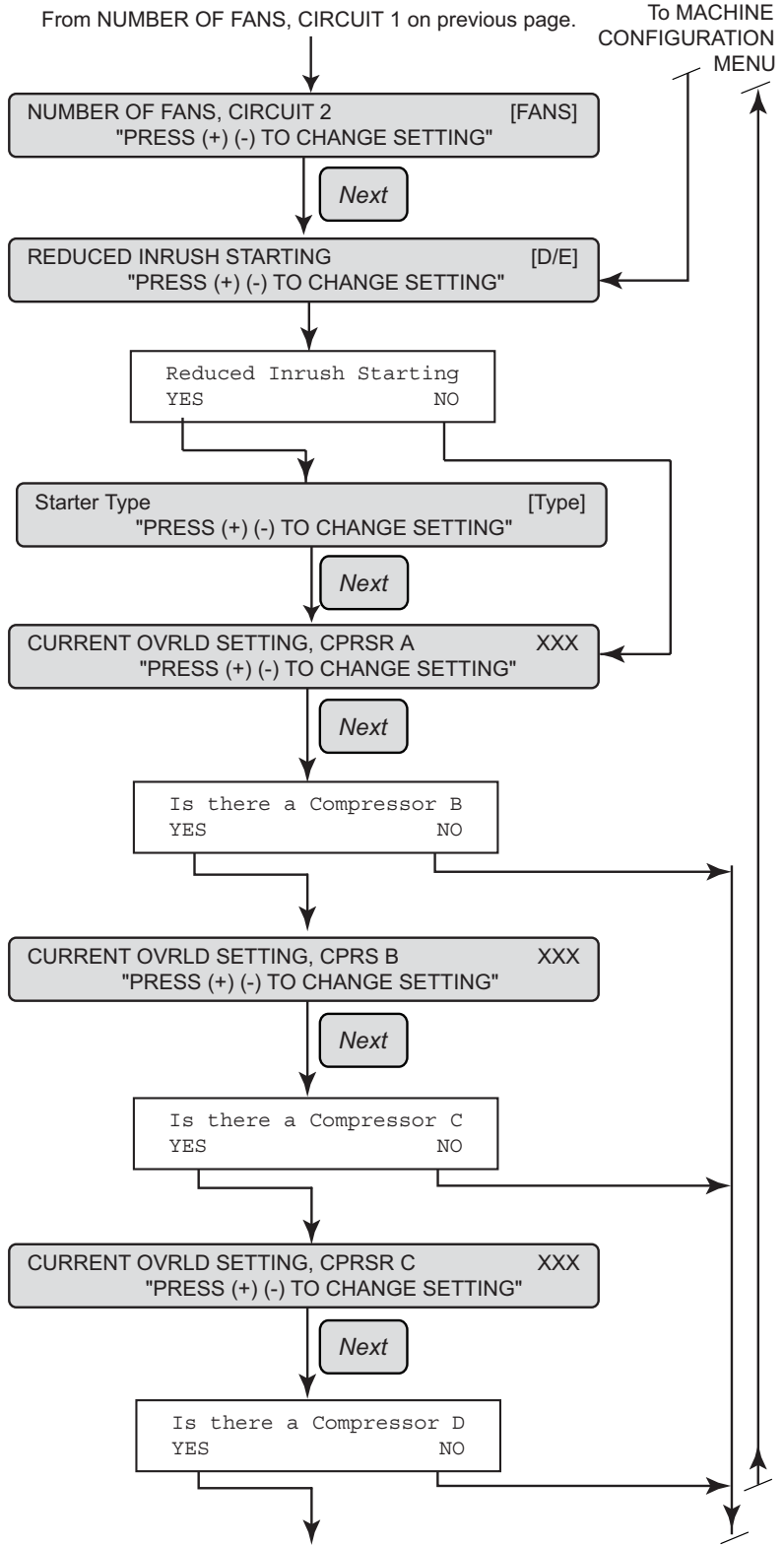

Controls Interface

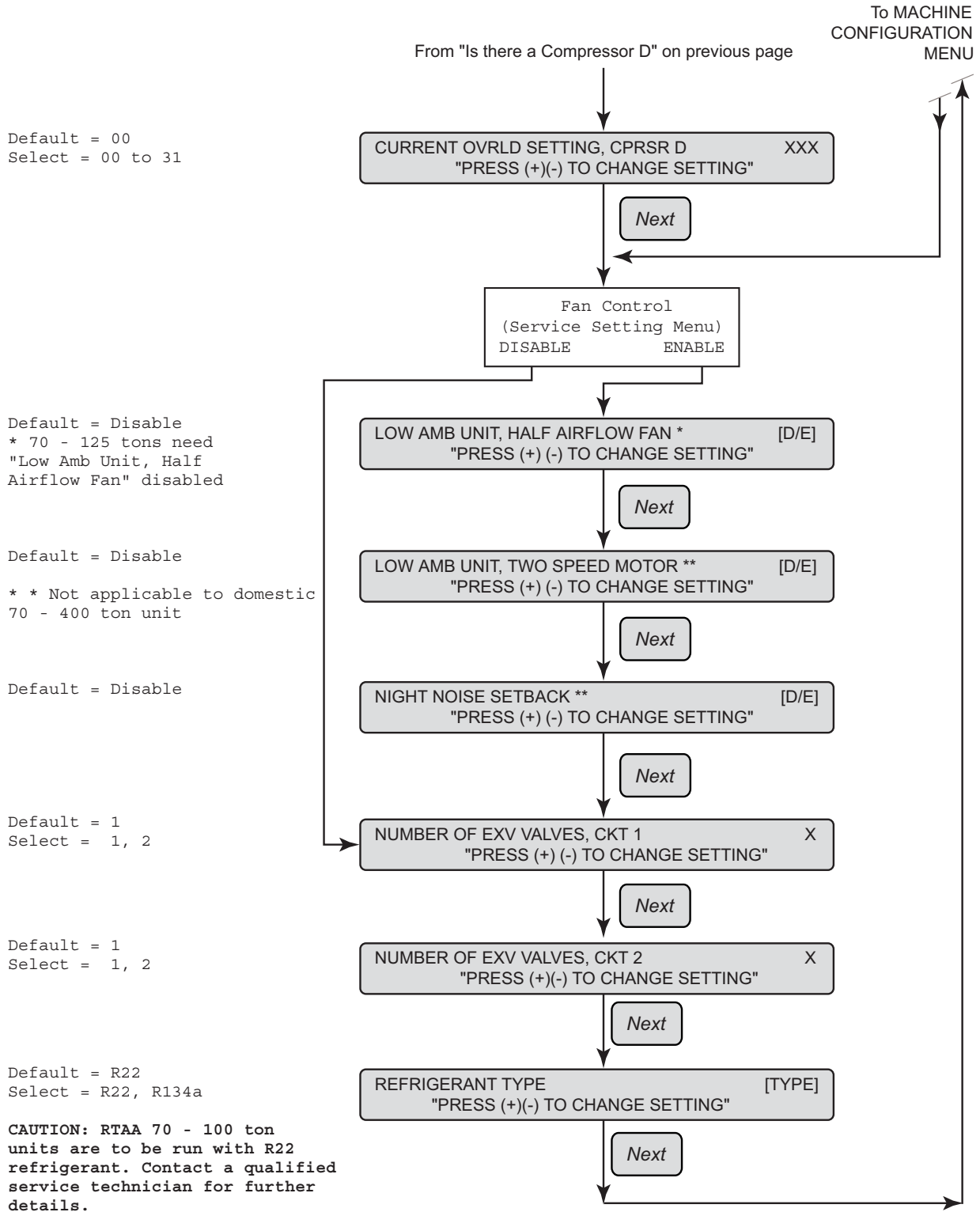

Controls Interface

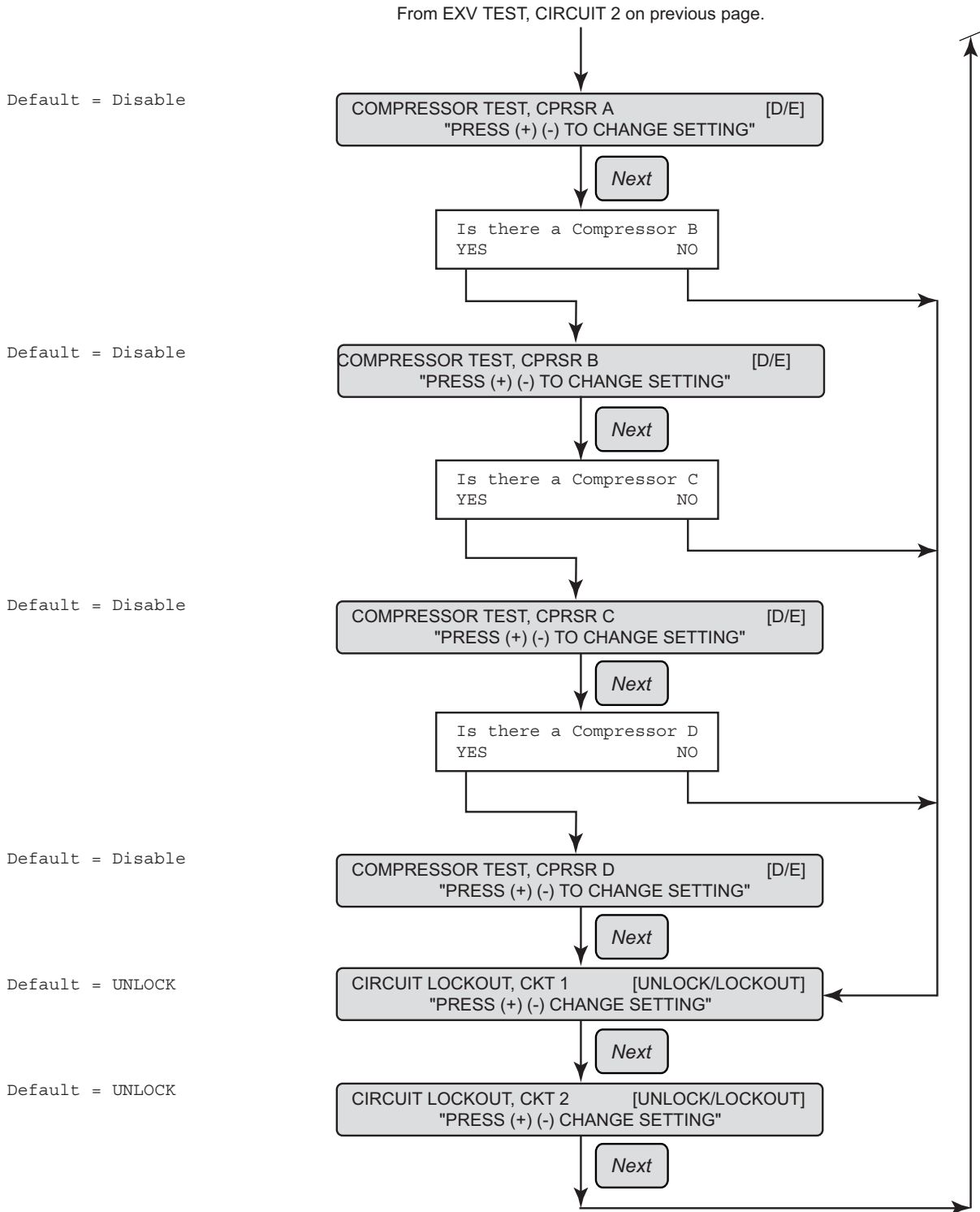



Controls Interface

Diagnostics

If there are no diagnostic messages, the selected menu item will be displayed continuously. If the Diagnostics key is pressed and there are no active diagnostics, the readout on the display will be

NO ACTIVE DIAGNOSTICS PRESENT

When a system malfunction occurs, one of the following appropriate diagnostic messages will be displayed:

A MACHINE SHUTDOWN HAS OCCURRED!

A MACHINE SHUTDOWN OCCURRED
BUT HAS CLEARED "PRESS (NEXT)"

A CIRCUIT SHUTDOWN HAS OCCURRED!

A CIRCUIT SHUTDOWN OCCURRED
BUT HAS CLEARED "PRESS (NEXT)"

INFORMATIONAL WARNING

AN INFORMATIONAL WARNING OCCURRED.
BUT HAS CLEARED "PRESS (NEXT)"

When a Circuit Shutdown – Manual Reset (CMR) or a Machine Shutdown – Manual Reset (MMR) occurs, the red LED to the right of the display will flash. Otherwise this alarm LED is deenergized.

If more than one diagnostic is present, only the highest priority active diagnostic will be explained in detail. For example, if three diagnostics occur in the following order before the operator returns – IFW, MMR, CMR – the display will read

*** A MACHINE SHUTDOWN HAS OCCURRED! ***

because the MMR has the highest priority. However, as the operator moves through the diagnostic menu to the "Last Diagnostic," the [Diagnostic Description] will show the CMR diagnostic as well as the IFW. If the "Next" key is pressed, the display will show all other active and historic diagnostics.

The active diagnostic priorities, listed from highest to lowest are:

- Machine Shutdown – Manual Reset (MMR)
- Machine Shutdown – Automatic Reset (MAR)
- Circuit Shutdown – Manual Rest (CMR)
- Circuit Shutdown – Automatic Reset (CAR)
- Informational Warning (IFW)

Use the Next key to enter the main diagnostic menu, where diagnostics can be cleared.

Important: Record diagnostic before pressing enter to clear.



Controls Interface

Operational Features

Entering Evaporator Water Temperature

When one or both compressors are running, the UCM continually monitors and compares the entering and leaving evaporator water temperatures. If the temperature of the entering water drops more than 2 F below the leaving water temperature for more than 100 degree F seconds, the UCM uses this to indicate a loss of water flow through the evaporator. This will shut down that circuit's compressor and will display an MMR diagnostic.

Current Limit Setpoint

The current limit setpoints for the system (front panel or remote) are entered through the Clear Language Display menus. The current limit setpoint for each compressor is shown in [Table 25](#).

Based upon current levels received at the UCM, the compressor slide valve is modulated to prevent the actual chiller current from exceeding the CLS.

When a compressor is turned off, the CLS for the remaining running compressor shall be reset upward immediately. When a compressor is added, the CLS for the running compressor shall be ramped downward at a rate not less than 10% RLA per minute to the new setpoint.

Low Ambient Lockout

The lockout provides a method for preventing unit start-up when the outdoor air temperature is below the setpoint. If the outdoor temperature goes below the setpoint during operation, the UCM will go through a normal shutdown of the unit. If the outdoor temperature subsequently increases to 5 F above the setpoint, the UCM will automatically re-enable the unit. The low ambient lockout feature has a range from -20 F to 60 F

Electronic Expansion Valve (EXV) Test

This test can be performed only when the Stop key has been pressed. It will confirm proper operation of the electronic expansion valve and the EXV module.

Once the test has been initiated at the Clear Language Display, the UCM will:

1. Overdrive the EXV closed (25 seconds)
2. Overdrive the EXV open (25 seconds)
3. Overdrive the EXV closed (25 seconds)
4. Reset the display to disable and end the test.

The EXV produces an audible clicking sound when it is driven against its end stops. Step 1 drives the EXV to its closed position, during which time service personnel can move from the Clear Language Display to the EXV.

NOTE: A tool may be needed to aid in hearing the clicking of the EXV, such as a screwdriver held between the EXV and the ear.

When Step 1 completes, the clicking stops and the UCM begins to open the EXV. When the EXV is fully opened, the valve will begin to click against its end stop. The service personnel must be prepared to time the period between the end of clicking in Step 1 and the beginning of clicking in Step 2.

The time between the end of clicking in Step 2 and the beginning of clicking in Step 3 must also be recorded. The time for the EXV to go from fully closed to fully open (which is the first time recorded) should be approximately 15 seconds. The time to go back to fully closed (which is the second time recorded) is approximately 15 seconds.



Controls Interface

Current Overload Protection

The UCM continually monitors compressor current to provide unit protection in the event of an overcurrent or locked rotor condition. Protection is based on the phase with the highest current and, if limits are exceeded, the UCM will shutdown the compressor and will display an MMR diagnostic.

Leaving Chilled Water Temperature Control

If the Auto key is pressed and a remote chilled water setpoint has been communicated, the UCM will control to the Remote Chiller Water Setpoint. Otherwise, it will control to the front panel setpoint. Control is accomplished by both staging compressors and modulating the slide valves on each compressor.

Upon start-up, if the leaving chilled water temperature is dropping 5 F per minute or faster, the chiller will not load further.

Table 25 Compressor(s) Current Limit Setpoints vs. Chiller Current Limit Setpoint (CLS)

System CLS	(70 - 125)	
	Number of compressors in operation	
	One	Two
120%	120	120
100%	120	100
80%	120	80
60%	120	60
40%	80	40

Chilled Water Reset (CWR)

As an option, the UCM will reset the chilled water temperature setpoint, based on either the return water temperature, zone air temperature, or outdoor air temperature. The 1U2 Module is necessary to preform CWR.

The following are selectable:

- One of four RESET TYPEs, from top to bottom in order of reset:
 - no CWR
 - RETURN WATER TEMPERATURE RESET
 - OUTDOOR AIR TEMPERATURE RESET

The Clear Language Display will not permit more than one type of reset to be selected in the Operator Settings Menu.

- RESET RATIO Setpoints. For OUTDOOR AIR TEMPERATURE RESET, there are both positive and negative reset ratios.
- START RESET Setpoints
- MAXIMUM RESET Setpoints. The maximum resets are with respect to the chilled water setpoint.

No matter which type of reset is selected all parameters are factory set to a predetermined set of values. Field adjustment of 2, 3, or 4 above, is usually not required.



Controls Interface

The equations for each type of reset are:

RETURN WATER TEMPERATURE RESET

$$CWS' = CWS + \text{RESET RATIO} [\text{START RESET} - (TWE - TWL)]$$

and $CWS' > \text{or} = CWS$

and $CWS' - CWS < \text{or} = \text{MAXIMUM RESET}$

OUTDOOR AIR TEMPERATURE RESET

$$CWS' = CWS + \text{RESET RATIO} [\text{START RESET} - \text{TOD}]$$

and $CWS' > \text{or} = CWS$

and $CWS' - CWS < \text{or} = \text{MAXIMUM RESET}$

CWS' is the new chilled water setpoint.

CWS is the active chilled water setpoint before any reset has occurred.

RESET RATIO is a user adjustable gain.

START RESET is a user adjustable reference.

TOD is the outdoor temperature.

TWE is the entering evaporator water temperature.

TWL is the leaving evaporator water temperature.

MAXIMUM RESET is a user adjustable limit, providing the maximum amount of reset.

NOTE: When any type of CWR is enabled, the UCM will step the CWS toward the desired CWS' (based on the above equations and setup parameters) at a rate of 1 F every 5 minutes. This applies when the chiller is both running and off. Normally the chiller will start at the Differential-to-Start value above a fully reset CWS or CWS'.

The values for RESET RATIO for each type of reset are:

Reset Type	Reset Ratio Range	Increment English Units	Increment SI Units	Factory Default Value
Return	10 to 120%	1%	1%	50%
Outdoor	80 to -80%	1%	1%	10%

The values for START RESET for each type of reset are:

Reset Type	Start Reset Range	Increment English Units	Increment SI Units	Factory Default Value
Return	4 TO 30 F (2.2 to 16.7 C)	1F	0.1C	10F (5.6 C)
Outdoor	50 to 130 F (10 to 54.4 C)	1F	0.1 C	90F (32.2 C)

The values for MAXIMUM RESET for each type of reset are:

Reset Type	Maximum Reset Range	Increment English Units	Increment SI Units	Factory Default Value
Return	10 to 20 F (-17.8 to -6.7 C)	1F	0.1C	5F (2.8 C)
Outdoor	0 to 20 F (-17.8 to -6.7 C)	1F	0.1 C	5F (2.8 C)



Controls Interface

Leaving Water Temperature Cutout

This temperature cutout provides protection against freezing caused by low leaving water temperature. The setpoint is both factory set and adjustable from the Service Settings Menu. Temperatures below the setpoint will cause the UCM to accelerate reduction of chiller capacity, even to the point of compressor shutdown. A non-latching diagnostic will be generated if the LWT is below the cutout for more than 30 degree F seconds.

There must be a minimum of 5 F between the cutout temperature and both the front panel and active chilled water setpoints. The Clear Language Display will not permit setting of either the front panel or active chilled water temperatures less than 5 F above this cutout temperature. The second line will state "Limited by Cutout Setpoint, (+) to change".

If the leaving water temperature cutout is set upward, the Clear Language Display will maintain the 5 F minimum and will automatically raise the settings on the front panel and active chilled water setpoints, if necessary.

If the front panel or Active Chilled Water Setpoints were adjusted, the display will show the following when the "Enter" key is pressed:

"FRONT PANEL CHILLED WATER SETPOINT
HAS BEEN INCREMENTED DUE TO CUTOUT
SETPPOINT CHANGE"

If the leaving water temperature drops below the cutout setpoint while the compressors are de-energized, it will produce an IFW diagnostic. If the leaving water temperature drops below the cutout setpoint while the compressors are energized for 30 F seconds, the unit will shut down on an MAR diagnostic.

Low Refrigerant Temperature Cutout

Both circuits are protected from a saturated evaporator refrigerant temperature that goes below this setting. The cutout setpoint must be a minimum of 15 F lower than the front panel or active chilled water setpoints. See [Table 26](#) for proper settings.

There must be a minimum of 15 F between the cutout temperature and both the front panel and active chilled water setpoints. The Clear Language Display will not permit setting of either the front panel or active chilled water temperatures less than 15 F above this cutout temperature and the display will flash the last valid temperature.



Controls Interface

Table 26 Leaving Fluid Temperature Setpoints

The leaving chilled water temperature is not the same as the ice termination setpoint. The ice termination setpoint is based on entering chilled water temperature. Therefore, the ice termination setpoint, minus temperature drop across the evaporator while in the ice making mode, equals the leaving chilled water temperature.

Leaving Chilled Water Temp - F	Leaving Water Temp Cutout - F	Low Refrig Temp Cutout - F	Recommended*** % Ethylene Glycol	Solution Freeze Point - F
40	35	22	0	32
39	34	20	3	
38	33	18	6	
37	32	17	8	
36	31	15	10	25
35	30	14	12	
34	29	12	14	
33	28	11	15	21
32	27	9	17	
31	26	7	19	
30	25	6	20	16
29	24	4	21	
28	23	2	23	
27	22	0	25	10
26	21	-1	26	
25	20	-3	28	
24	19	-5	29	
23	18	-6	30	4
22	17	-8	31	
21	16	-10	33	
20	15	-11	34	
19	14	-13	35	-3
18	13	-15	36	
17	12	-17	37	
16	11	-18	38	
15	10	-19	39	
14	9	-21	40	-11
13	8	-23	41	
12	7	-24	42	
11	6	-26	43	
10	5	-27	43	
9	4	-29	44	
8	3	-31	45	-21
7	2	-32	46	
6	1	-34	47	
5	0	-35	47	
4	-1	-37	48	
3	-2	-38	49	
2	-3	-39	50	-32
1	-4	-39	50	
0	-5	-39	50	

***Recommended% Ethylene Glycol will give freeze protection consistent with other chiller safety controls (solution freeze point is nominally 10°F above refrig temp cutout).

Controls Interface

If the leaving water temperature cutout is set upward, the Clear Language Display will maintain the 15 F minimum and will automatically raise the settings on the front panel and active chilled water setpoints, if necessary.

If the front panel or Active Chilled Water Setpoints were adjusted, the display will show the following when the "Enter" key is pressed:

"FRONT PANEL CHILLED WATER SETPOINT
HAS BEEN INCREMENTED DUE TO CUTOUT
SETPOINT CHANGE"

If the saturated evaporator refrigerant temperature for a circuit drops below this setpoint for longer than 30 degree F seconds, the circuit will be shutdown and a CMR diagnostic will be displayed.

NOTE: Ice Termination will allow cutouts to be set anywhere, although when running, software follows 5 F and 15 F rules.

Low Ambient Temperature Start

The Low Refrigerant Temperature Cutout (LRTC) and Low Pressure Cutout (LPC) on a circuit is ignored, briefly, each time the circuit is started. The "ignore time" is a function of the Saturated Condenser Refrigerant Temperature at the time the compressor starts, as shown in [Figure 40](#).

Low Refrigerant Temperature Cutout and Low Pressure Cutout Retry

If the LRTC or LPC trips despite the low ambient temperature start logic, the circuit will be permitted to shutdown and retry one time.

If the LRTC or LPC trips within the first 20 minutes after initial start but after the low ambient ignore time (grace period), the compressor stops immediately and the Restart Inhibit timer is set to one minute. After time expires, the compressor will reset if there is a call for cooling.

If the LRTC or LPC trips again during the grace period, a CMR diagnostic will occur. If there is an LRTC or LPC trip anytime after the grace period, a CMR diagnostic will occur.

Balanced Compressor Starts and Hours

This feature is enabled/disabled in Balanced Starts and Hours (Service Settings Menu). When enabled, the UCM will start the compressor with the fewest starts and stop the compressor with the greatest hours, as determined by the "Compressor Starts" accumulator and the "Compressor Hours" accumulator. This will tend to balance out hours and starts equally over both compressors.

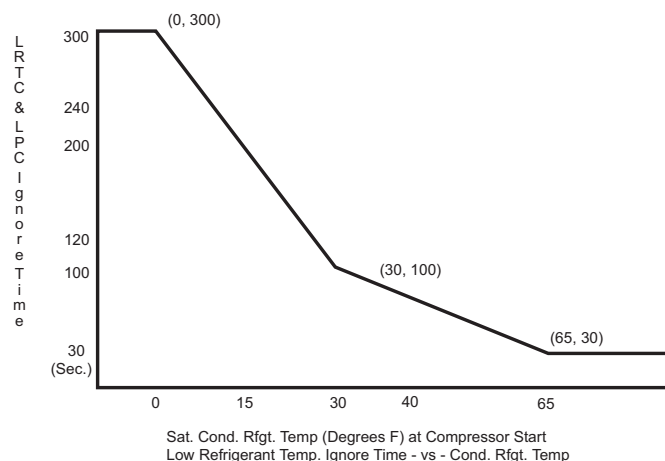

Figure 40 Low Refrigerant Temp and Low Pressure Cutout Ignore Time



Controls Interface

Phase Imbalance Protection

The Clear Language Display monitors the current in each phase and calculates the percentage of imbalance as follows:

$$\% \text{ Imbalance} = \frac{(I_x - I_{\text{ave}}) \times 100}{I_{\text{ave}}}$$

$$I_{\text{ave}} = \frac{(I_1 + I_2 + I_3)}{3}$$

I_x = phase with greatest difference from I_{ave} (without regard to sign)

If Phase Unbalanced Protection (Service Settings Menu) is enabled, and the average three phase current is greater than 80% RLA, and the percent of imbalance is calculated to exceed 15%, the UCM will shutdown the compressor and display a CMR diagnostic.

In addition to the 15% criteria, the Clear Language Display has a non-defeatable 30% criteria which has its own diagnostic. If the 15% criteria is enabled, it will always display the 15% diagnostic first. The 30% criteria is always active when a compressor is running, regardless of % RLA.

Reverse Rotation Protection

The Clear Language Display monitors incoming current during start-up and will shutdown the compressor within one second, if phase reversal is detected.

CAUTION

Reversed Phase Rotation!

Phase relationships during installation of unit power must be carefully controlled to assure compressor protection against reversed phase rotation. See Installation - Electrical.

Oil Failure Protection

The 70 to 125 Ton units no longer use the differential pressure switch to monitor for an oil line restriction. The logic of the UCM uses a comparison of the entering oil temperature at the compressor to the saturated condenser temperature to determine if there is an oil line restriction.

The differential between the entering oil temperature and the saturated condenser temperature is referred to as the "Oil Loss Differential Setpoint" in the Service Settings Menu. This setpoint must remain at the default of -4 F for the unit to function properly.

If the entering oil temperature drops 4 F below the saturated condenser temperature for more than 30 minutes, the circuit will shutdown on a CMR diagnostic. The diagnostic will be presented as:

"OIL SYSTEM FAULT - CKT X°



Controls Interface

DIP Switch Settings

Compressor Overload DIP Switches

The settings for these switches are shown in [Table 27](#).

Table 27 Compressor Overload DIP Switch Settings

RTWA (Std. Cond. Temp.) DIP Switch Settings					RTWA (Std. Cond. Temp.) DIP Switch Settings				
Tons	VAC/Hz	RLA	C.T.*	Overload Setting **	Tons	VAC/Hz	RLA	C.T.*	Overload Setting **
35	575/60	37	-09	01001/09	35	575/60	40	-09	01111/15
	460/60	46	-09	11001/25		460/60	50	-10	00000/00
	380/60	55	-10	01000/08		380/60	61	-10	10000/16
	230/60	91	-01	11001/25		230/60	100	-01	11111/31
	200/60	105	-02	00100/04		200/60	115	-02	01011/11
	400/50	44	-09	10110/22		400/50	50	-10	00000/00
	220/50	80	-01	01111/15		220/50	87	-01	10110/22
40	575/60	43	-09	10100/21	40	575/60	50	-10	00000/00
	460/60	54	-10	00111/07		460/60	62	-10	10001/17
	380/60	65	-10	10101/21		380/60	75	-01	01010/10
	230/60	108	-02	00111/07		230/60	124	-02	10001/17
	200/60	124	-02	10001/17		200/60	142	-02	11011/27
	400/50	52	-10	00011/03		400/50	62	-10	10001/17
	220/50	94	-01	11011/27		220/50	108	-02	00111/07
50	575/60	57	-10	01011/11	50	575/60	67	-01	00001/01
	460/60	72	-01	00111/07		460/60	84	-01	10011/19
	380/60	87	-01	10110/22		380/60	101	-02	00001/01
	230/60	143	-03	00110/06		230/60	167	-03	10010/18
	200/60	164	-03	10001/17		200/60	192	-03	11100/28
	400/50	69	-01	00011/03		400/50	84	-01	10011/19
	220/50	126	-02	10011/19		220/50	147	-03	01000/08
60	575/60	68	-01	00010/02	60	575/60	81	-01	10000/16
	460/60	85	-01	10100/20		460/60	101	-02	00001/01
	380/60	102	-02	00010/02		380/60	123	-02	10001/17
	230/60	169	-03	11011/27		230/60	203	-04	01000/08
	200/60	194	-04	10011/19		200/60	233	-04	10011/19
	400/50	82	-01	10001/17		400/50	101	-02	00001/01
	220/50	148	-03	01001/09		220/50	176	-03	10110/22

* The Current Transformer base part number is X13580253. The numbers in this column are suffixes to the base number.

** On the DIP switch, 1=ON, 0=OFF. The decimal value should be set in the compressor overload setting menu of the UCM. If the DIP switch value does not match the decimal value entered into the UCM, the related compressor(s) will continue to run, but a diagnostic will be initiated, both settings will be ignored, and the UCM will use the lowest possible trip setting value.

IPC Address

The IPC address set the address for Inter-Processor Communications of the Clear Language Display modules. The following is the IPC DIP switch settings for the RTAA 70 – 125 modules.



Controls Interface

IPC DIP SWITCH	MODULE			
	1U3	1U4	1 US	1U7
1	OFF	OFF	OFF	OFF
2	OFF	OFF	ON	OFF
3	—	—	—	ON

2-10 VDC/4-20 mA Input for External Chilled Water Setpoint (CWS) and Current Limit Setpoint (CLS)

When either external CWS or external CLS is used on the optional Module 1U2, DIP switch SW1 positions 1 and/or 2 must be set to accommodate the type of signal source the customer has chosen, either 2-10 VDC or 4-20 mA. Position SW-1-1 sets 2-10 VDC/4-20 mA for external CWS. SW1-2 sets 2-10 VDC/4-20 mA for external CLS. The "OFF" setting configures the external input for 2-10 VDC; the "ON" setting configures the external input for 4-20 mA.

Mechanical Control Settings

The settings for the High Pressure switch, Oil Pressure switch, and Winding Thermostat are shown below:

	CLOSE	OPEN
Compressor Discharge High Pressure Switch – PSIG	300 ±20	405 ±7
Compressor Motor Winding Thermostat – F	181	221

Remote CLD Operation

With only few exceptions, operation of the Remote CLD is identical to the unit's CLD. To ease the operation of the Remote CLD, additional displays have been added. For example, if multiple unit operation is used, the following display will be inserted as the second display of the setpoint group:

Modify Setpoints for Units X
 "Press (+) (-) to change settings"

The Stop and Auto keys function in the same manner, but the following hierarchy between the unit's Stop/Auto keys and the Remote CLD Stop/Auto keys is as follows:

1. Local Stop will always override Local Auto, Remote Stop and Remote Auto.
2. Local Auto will always override Local Stop, Remote Stop and Remote Auto.
3. Remote Stop will override Local Auto and Remote Auto but not Local Stop.
4. Remote Auto will override Local Auto and Remote Stop but not Local Stop.

If an operator tries to start the unit from the Remote CLD after the Stop command has been given at the unit CLD, the screen on the Remote CLD will read:

"LOCAL STOP command at unit cannot be
 overridden by this remote device"

Communication Failure

If a communication failure occurs between the Remote CLD and the unit's CLD, the setpoints will remain the same but a diagnostic will occur at the Remote CLD panel. The Remote display screen will read:

"No communication to Unit X"
 Press (enter) to select new unit



Pre-Start Checkout

When installation is complete, but prior to putting the unit into service, the following pre-start procedures must be reviewed and verified correct:

⚠ WARNING

Hazardous Voltage w/Capacitors!

Disconnect all electric power, including remote disconnects before servicing. Follow proper lockout/tagout procedures to ensure the power cannot be inadvertently energized. For variable frequency drives or other energy storing components provided by Trane or others, refer to the appropriate manufacturer's literature for allowable waiting periods for discharge of capacitors. Verify with an appropriate voltmeter that all capacitors have discharged. Failure to disconnect power and discharge capacitors before servicing could result in death or serious injury.

Note: For additional information regarding the safe discharge of capacitors, see PROD-SVB06A-EN or PROD-SVB06A-FR

- Inspect all wiring connections to be sure they are clean and tight.
- Verify that all refrigerant valves, as shown in [Figure 35](#) and [36](#), are "OPEN"

CAUTION

Compressor Damage!

Do not operate the unit with the compressor, oil discharge, liquid line service valves and the manual shutoff on the refrigerant supply to the auxiliary coolers "CLOSED". Failure to have these "OPEN" may cause serious compressor damage.

- Check the power supply voltage to the unit at the main power fused-disconnect switch. Voltage must be within the voltage utilization range, given in [Table 16](#) and also stamped on the unit nameplate. Voltage imbalance must not exceed 2 percent. Refer to Paragraph "[Unit Voltage Imbalance](#)" on [Page 124](#).
- Check the unit power phasing to be sure that it has been installed in an "ABC" sequence. Refer to Paragraph "[Unit Voltage Phasing](#)" on [Page 124](#).

⚠ WARNING

Prevent Injury!

It is imperative that LI-L2-L3 in the starter be connected in the A-B-C phase sequence to prevent equipment damage due to reverse rotation.



Pre-Start Checkout

- Fill the evaporator and condenser chilled water circuits. Refer to Table 1 for liquid capacities. Vent the system while it is being filled. Open the vents on the top of the evaporator and condenser during filling and close when filling is completed.

Customer Note

The use of improperly treated or untreated water in this equipment may result in scaling, erosion, corrosion, algae or slime. The services of a qualified water treatment specialist should be engaged to determine what treatment, if any, is advisable. The Trane Company warranty specifically excludes liability of corrosion, erosion or deterioration of Trane equipment. Trane assumes no responsibilities for the results of the use of untreated or improperly treated water or saline or brackish water.

CAUTION: **Equipment Damage!**

Do not use untreated or improperly treated water. Equipment damage may occur.

- Close the fused-disconnect switch(es) that supplies power to the chilled water pump starter and the condenser water pump starter.
- For RTCA units, close the fused-disconnect switches that supply power to the fans.
- Start the chilled water pump and condenser water pump to begin circulation of the water. Inspect all piping for leakage and make any necessary repairs.
- With water circulating through the system, adjust water flow and check water pressure drop through the evaporator and condenser. Refer to [Figures 16, 17 and 18](#).
- Adjust the chilled water flow switch and condenser water flow switch (if installed) for proper operation.
- Prove all Interlock and Interconnecting Wiring Interlock and External as described in Section "[Installation - Electrical](#)".
- Check and set, as required, all Clear Language Display Menu Items.
- Stop the chilled water pump and condenser water pump.

Unit Voltage Power Supply

⚠ WARNING

Live Electrical Components!

During installation, testing, servicing and troubleshooting of this product, it may be necessary to work with live electrical components. Have a qualified licensed electrician or other individual who has been properly trained in handling live electrical components perform these tasks. Failure to follow all electrical safety precautions when exposed to live electrical components could result in death or serious injury.



Pre-Start Checkout

Voltage to the unit must meet the criteria given in [Table 16](#). Measure each leg of the supply voltage at the unit's main power fused-disconnect. If the measured voltage on any leg is not within specified range, notify the supplier of the power and correct the situation before operating the unit.

CAUTION

Equipment Damage!

Inadequate voltage to the unit may cause control components to malfunction and shorten the life of relay contact, compressor motors and contactors.

Unit Voltage Imbalance

Excessive voltage imbalance between the phases of a three-phase system can cause motors to overheat and eventually fail. The maximum allowable imbalance is 2 percent. Voltage imbalance is determined using the following calculations:

$$\% \text{ Imbalance} = \frac{(I_x - I_{ave}) \times 100}{I_{ave}}$$

$$V_{ave} = \frac{(V_1 + V_2 + V_3)}{3}$$

V_x = phase with greatest difference from V_{ave} (without regard to sign)

For example, if the three measured voltages are 221, 230, and 227 volts, the average would be:

$$\frac{221 + 230 + 227}{3} = 226$$

The percentage of imbalance is then:

$$\frac{100(221 - 226)}{226} = 2.2\%$$

This exceeds the maximum allowable (2%) by 0.2 percent.

Unit Voltage Phasing

It is important that proper rotation of the compressors be established before the unit is started. Proper motor rotation requires confirmation of the electrical phase sequence of the power supply. The motor is internally connected for clockwise rotation with the incoming power supply phased A, B, C.

Basically, voltages generated in each phase of a polyphase alternator or circuit are called phase voltages. In a three-phase circuit, three sine wave voltages are generated, differing in phase by 120 electrical degrees. The order in which the three voltages of a three-phase system succeed one another is called phase sequence or phase rotation. This is determined by the direction of rotation of the alternator. When rotation is clockwise, phase sequence is usually called "ABC"; when counterclockwise, "CBA".



Pre-Start Checkout

This direction may be reversed outside the alternator by interchanging any two of the line wires. It is this possible interchange of wiring that makes a phase sequence indicator necessary if the operator is to quickly determine the phase rotation of the motor.

Proper compressor motor electrical phasing can be quickly determined and corrected before starting the unit. Use a quality instrument, such as the Associated Research Model 45 Phase Sequence Indicator.

1. Press the Stop key on the Clear Language Display.
2. Open the electrical disconnect or circuit protection switch that provides line power to the line power terminal block(s) in the starter panel (or to the unit-mounted disconnect).
3. Connect the phase sequence indicator leads to the line power terminal block, as follows:



Pre-Start Checkout

<u>Phase</u>	<u>Sea. Lead</u>	<u>Terminal</u>
Black (Phase A)	L1
Red (Phase B)	L2
Yellow (Phase C)	L3

4. Turn power on by closing the unit supply power fused-disconnect switch.
5. Read the phase sequence on the indicator. The “ABC” LED on the face of the phase indicator will glow if phase is “ABC”.
6. If the “CBA” indicator glows instead, open the unit main power disconnect and switch two line leads on the line power terminal block(s) (or the unit mounted disconnect). Reclose the main power disconnect and recheck the phasing.

CAUTION Equipment Damage!

Do not interchange any load leads that are from the unit contactors or the motor terminals.

7. Reopen the unit disconnect and disconnect the phase indicator.

Water System Flow Rates

Establish a balanced chilled water flow through the evaporator. The flow rates should fall between the minimum and maximum values given in Table 1. Chilled water flow rates below the minimum values will result in laminar flow, which reduces heat transfer and causes either loss of EXV control or repeated nuisance, low temperature cutouts. Flow rates that are too high can cause tube erosion and damage to the tube supports and baffles in the evaporator. The flow rates through the condenser must also be balanced, according to the flow rates in Table 1.

Water System Pressure Drop

Measure water pressure drop through the evaporator and condenser at the field-installed pressure taps on the system water piping. Use the same gauge for each measurement. Do not include valves, strainers fittings in the pressure drop readings.

Pressure drop readings should be approximately those shown in the Pressure Drop Charts, Figures 16, 17 and 18.



Start-Up Procedures

If the pre-start checkout, as discussed above, has been completed, the unit is ready to start. The Clear Language Display is shown in [Figure 39](#) and Clear Language Display Sequence of Operation is shown in [Figure 41](#). Complete each step, in sequence, as follows:

- Press the Stop key on the Clear Language Display.
- As necessary, adjust the setpoint values in the Clear Language Display menus, as described in Paragraph "[Clear Language Display Keypad Overview](#)" on [Page 91](#).
- Close the fused-disconnect switch for the chilled water pump and condenser water pump. Energize the pumps to start water circulation.
- Check the service valves on the discharge line, suction line, oil line and liquid line for each circuit. These valves must be open (backseated) before starting the compressors.

CAUTION: **Compressor Damage!**

To prevent compressor damage, do not operate the unit until all refrigerant and oil line service valves are opened.

- Verify that the chilled water pump runs for one minute after the chiller is commanded to stop (for normal chilled water systems). See Paragraph "[Interconnecting Wiring](#)" on [Page 62](#).
- Press the Auto key. If the chiller control calls for cooling and all safety interlocks are closed, the unit will start. The compressor(s) will load and unload in response to the temperature of the leaving chilled water temperature.

Once the system has been operating for approximately 30 minutes and has become stabilized, complete the start-up procedures, as follows:

- Check the evaporator refrigerant pressure and the condenser refrigerant pressure under Refrigerant Report on the Clear Language Display. The pressures are referenced to sea level (14.6960 psia).
- Check the liquid line sight glasses. The refrigerant flow past the sight glasses should be clear. Bubbles in the refrigerant indicate either low refrigerant charge or excessive pressure drop in the liquid line. A restriction in the line can sometimes be identified by a noticeable temperature differential between the two sides of the restriction. Frost may often form on the line at this point. Proper refrigerant charges are shown in [Table 1](#).

NOTE: A clear sight glass alone does not mean that the system is properly charged. Also check system superheat, subcooling, and unit operating pressures.

- Measure the system superheat. Refer to Paragraph "[System Superheat](#)" on [Page 128](#).
- Measure the system subcooling. Refer to Paragraph "[System Subcooling](#)" on [Page 128](#).
- A shortage of refrigerant is indicated if operating pressures are low and



Start-Up Procedures

subcooling is also low. If the operating pressures, sight glass, superheat and subcooling readings indicate a refrigerant shortage, gas-charge refrigerant into each circuit, as required. With the unit running, add refrigerant vapor by connecting the charging line to the suction service valve and charging through the backseat port until operating conditions become normal.

NOTE: If both suction and discharge pressures are low but subcooling is normal, a problem other than refrigerant shortage exists. Do not add refrigerant, as this may result in overcharging the circuit.

NOTE: Use only refrigerants specified on the unit nameplate, to prevent compressor damage and insure full system capacity.

- If operating conditions indicate a refrigerant overcharge, remove refrigerant at the liquid line service valve. Allow refrigerant to escape slowly, to minimize oil loss. Do not discharge refrigerant into the atmosphere.

System Superheat

Normal suction superheat for each circuit is approximately 6 F (4 F for RTUA units) at full operating load. Superheat temperature can be expected to be moving around the 6 F (4 F for RTUA) setpoint when the chiller is pulling down or the compressor slide valve is being modulated. Superheat can be expected to settle out at approximately 6 F (4 F for RTUA units) when the above items stabilize.

System Subcooling

Normal subcooling for each circuit ranges from 6 F to 8 F, depending on the unit. If subcooling for either circuit does not approximate these figures, check the superheat for the circuit and adjust, if required. If superheat is normal but subcooling is not, contact a qualified service technician.



Unit Shutdown Procedures

Temporary Shutdown and Restart

To shut the unit down for a short time, use the following procedure:

1. Press the Stop key on the Clear Language Display. The compressors will continue to operate and, after unloading for 20 seconds, will stop when the compressor contactors de-energize.
2. Stop the water circulation by turning off both the chilled water pump and condenser pump.

To restart the unit after a temporary shutdown, restart the chilled water pump and press the AUTO key. The unit will start normally, provided the following conditions exist:

1. The UCM must receive a call for cooling and the differential to-start must be above the setpoint.
2. All system operating interlocks and safety circuits must be satisfied.

Extended Shutdown Procedure

The following procedure is to be followed if the system is to be taken out of service for an extended period of time, eg., seasonal shutdown:

1. Test the unit for refrigerant leakage and repair as necessary.
2. Open the electrical disconnect switches for the chilled water pump. Lock the switch in the "OPEN" position.

CAUTION

Pump Damage!

Lock the chilled water pump and condenser water pump disconnects open, to prevent pump damage.

3. Close all chilled water supply valves. Drain the chilled water from the evaporator and condenser.
4. Open the unit main electrical disconnect and unit mounted disconnect (if installed) and lock on the "OPEN" position. If optional control power transformer is not installed, open and lock the 115 V disconnect.

CAUTION

Accidental Start-up!

Lock the disconnects on the "OPEN" position to prevent accidental start-up and damage to the system when it has been setup for extended shutdown.

5. At least every three months (quarterly), check the pressure in the unit to verify that the refrigerant charge is intact.

System Restart after Extended Shutdown

Follow the procedures below to restart the unit after extended shutdown:

1. Verify that the liquid line service valves, oil line, compressor discharge service valves and suction service valves are open (backseated).



Unit Shutdown Procedures

CAUTION: Compressor Damage!

To prevent damage to the compressor, be sure that all refrigerant valves are open before starting the unit.

2. Check the oil separator oil level. See Paragraph "[Oil Separator Level Check](#)" on Page 139.
3. Fill the evaporator and condenser water circuits. Refer to Table 1 for evaporator and condenser liquid capacities. Vent the system while it is being filled. Open the vent on the top of the evaporator and condenser during filling and close when filling is completed.

Proper Water Treatment!

The use of untreated or improperly treated water in a CenTraVac may result in scaling, erosion, corrosion, algae or slime. It is recommended that the services of a qualified water treatment specialist be engaged to determine what water treatment, if any, is required. Trane assumes no responsibility for equipment failures which result from untreated or improperly treated water, or saline or brackish water.

4. Close the fused-disconnect switches that provides power to the chilled water pump and the condenser water pump.
5. Start both the evaporator and condenser water pumps and, while water is circulating, inspect all piping for leakage. Make any necessary repairs before starting the unit.
6. While the water is circulating, adjust the water flows and check the water pressure drops through the evaporator and the condenser. Refer to "Water System Flow Rates" and "Water System Pressure Drop".
7. Adjust the flow switch on the evaporator piping and condenser piping (if installed) for proper operation.
8. Stop both water pumps. The unit is now ready for start-up as described in "Start-Up Procedures".



Periodic Maintenance

Perform all maintenance procedures and inspections at the recommended intervals. This will prolong the life of the equipment and minimize the possibility of costly failures.

Use an "Operator's Log" to record an operating history for the unit. The log serves as a valuable diagnostic tool for service personnel. By observing trends in operating conditions, an operator can anticipate and prevent problem situations before they occur.

Weekly Maintenance

After the unit has been operating for approximately 30 minutes and the system has stabilized, check the operating conditions and complete the procedures below:

- Check the evaporator refrigerant pressure and the condenser refrigerant pressure in the Refrigerant Report Menu on the Clear Language Display. The pressures are referenced to sea level (14.6960 psia).
- Check the liquid line sight glasses. The refrigerant flow past the sight glasses should be clear. Bubbles in the refrigerant indicate either low refrigerant charge or excessive pressure drop in the liquid line. A restriction in the line can sometimes be identified by a noticeable temperature differential between the two sides of the restriction. Frost may often form on the line at this point. Proper refrigerant charges are shown on [Table 1](#).

CAUTION

Equipment Check!

A clear sight glass alone does not mean that the system properly charged. Also check system superheat, subcooling, and unit operating pressures.

- If operating pressures and sight glass conditions seem to indicate refrigerant shortage, measure the system superheat and system subcooling. Refer to Paragraphs "[System Superheat](#)" on Page 128 and "[System Subcooling](#)" on Page 128.
- If operating conditions indicate a refrigerant overcharge, remove refrigerant at the liquid line service valve. Use appropriate refrigerant recovery practices that allow refrigerant to escape slowly, to minimize oil loss. Do not discharge refrigerant into the atmosphere.
- Inspect the entire system for unusual conditions.

Monthly Maintenance

- Perform all weekly maintenance procedures.
- Measure and record the system superheat. Refer to Paragraph "[System Superheat](#)" on Page 128.
- Measure and record the system subcooling. Refer to Paragraph "[System Subcooling](#)" on Page 128.

Annual Maintenance

- Perform all weekly and monthly maintenance procedures.



Periodic Maintenance

- Check the refrigerant charge and oil level. Refer to Paragraphs ["Weekly Maintenance" on Page 133](#) and ["Oil Separator Level Check" on Page 139](#). Routine changing of oil is not required.
- Have a qualified laboratory perform a compressor oil analysis to determine system moisture content and acid level. This analysis is a valuable diagnostic tool.
- Check the pressure drop across the oil filter. See Paragraph ["Oil Filter Change" on Page 140](#).
- Contact a qualified service organization to leak test the chiller, to check operating and safety controls, and to inspect electrical components for deficiencies.
- Inspect all piping components for leakage and damage. Clean out any inline strainers.
- Clean and repaint any areas that show signs of corrosion.



Periodic Maintenance

RTWA/RTUA Operator's Log						
Job Name:			Job Location:			
Unit Serial Number:			Elevation Above Sea Level:			
Model No:			Nameplate Voltage:			
Compressor A Serial Number:			Fan Motor RLA			
Compressor A Model Number:			Heat Tape Voltage			
Compressor B Serial Number:						
Compressor B Model Number:						
Evap Water Pressure Drop						
Design PSID:		Actual PSID:				
Design GPM:		Actual GPM:				
Circuit			1	2	1	2
Compressor			A	B	A	B
			15 min	15 min	30 min	30 min
Unit	Phase	A-B				
Voltage		A-C				
		B-C				
Compressor	Phase	A				
Amps		B				
		C				
Unit Operating Mode						
Last Diagnostic						
Evaporator Entering Water Temp.		<i>F or C</i>				
Evaporator Leaving Water Temp.		<i>F or C</i>				
Outdoor Air Temperature		<i>F or C</i>				
Active Chill Water Setpoint		<i>F or C</i>				
Active Current Limit Setpoint						
Saturated Evaporator Rfgt.Temp.		<i>F or C</i>				
Saturated Condenser Rfgt. Temp.		<i>F or C</i>				
Condenser Refrigerant Pressure		<i>psig/kPa</i>				
Evaporator Refrigerant Pressure		<i>psig/kPa</i>				
Compressor RLA		<i>% RLA</i>				
Compressor Starts						
Compressor Hours						
External Hardwired Lockout			Not Locked out/ Locked out		Not Locked out/ Locked out	
Front Panel Lockout			Not Locked out/ Locked out		Not Locked out/ Locked out	



Periodic Maintenance

RTWA & RTUA Log			
Operator Settings:			
Set Point Source		Low Wtr Temp EXV Gain Comp [D/E]	
Front Panel Chilled Wtr Setpt		Condenser Limit Setpt	
External Chilled Wtr Setpt [D/E]		Phase Unbalance Protection [D/E]	
Design Delta Temp Setpt		Phase Reversal Protection [D/E]	
Differential To Start Setpt		Superheat Setpt	
Chilled Water Pump [On/Auto]		EXV Control Response Ckt 1	
Chilled Water Pump Off Delay		EXV Control Response Ckt 2	
Front Panel Current Limit Setpt		LVG Wtr Temp Cntrl Resp Setpt	
External Current Limit Setpt [D/E]		Fan Cntrl Deadband Bias, Ckt 1	
Low Ambient Lockout [D/E]		Fan Cntrl Deadband Bias, Ckt 2	
Low Ambient Lockout Setpt		Title Machine Config. Menu (++++)	
Chilled Water Reset Type		Compressor Model No. Prefix	
Type, Reset Ratio		Number of Compressors	
Type, Start Reset Setpt		Oil Loss Differential Setpt	
Type, Max Reset Setpt		Compressor A Tons	
Ice Machine Control [D/E]		Compressor B Tons	
Panel Ice Termination Setpt		Unit Model	
Title Service Settings		Fan Control [D/E]	
Under/Over Voltage Protection [D/E]		Variable Speed Fan, Circuit 1 [D/E]	
Unit Line Voltage		Variable Speed Fan, Circuit 2 [D/E]	
Restart Inhibit Time		Number of Fans, Circuit 1	
Balanced CPRSR Starts & Hours [D/E]		Number of Fans, Circuit 2	
Display Units		Reduced Inrush Starting [D/E]	
Programmable Relay Setup		Current OvrlD Setting, CPRSR A	
External Circuit Lockout [D/E]		Current OvrlD Setting, CPRSR B	
Service Set-up Menu (++- -++)		Low Amb Unit, Half Airflow Fan [D/E]	
Keypad/Display Lock Feature [D/E]		Low Amb Unit, Two Speed Motor [D/E]	
ICS Address		Night Noise Setback [D/E]	
LVG Wtr Temp Cutout Setpt		Number of EXV Valves, Ckt 1	
Low Rfgt Temp Cutout Setpt		Number of EXV Valves, Ckt 2	

Maintenance

This section describes specific maintenance procedures which must be performed as a part of the normal maintenance program for this unit. Be certain that electrical power to the unit is disconnected before performing these procedures.

⚠ WARNING

Prevent Injury!

Position all electrical disconnects in the "OPEN" position and lock them, to prevent injury or death due to electrical shock.

Cleaning the Evaporator (RTWA and RTUA)

The evaporator water system is a part of a closed loop and should not accumulate an appreciable amount of scale or sludge. If it is determined that the chiller is fouled, first attempt to dislodge any foreign material by backflushing the system several times. If this does not work satisfactorily, chemically clean the chiller using the procedures outlined in Paragraph ["Mechanical Cleaning \(RTWA\)" on Page 137](#).

Cleaning the Condenser

General (RTWA)

Water available for condensing frequently contains minerals or other contaminants that collect on the inside of the condenser tubes as carbonate scale. Scale accumulation will accelerate with high condensing temperatures and use of water with high mineral content. Cooling towers collect dust and foreign material which also deposit on the condenser tubes, forming sludge.

To maintain maximum efficiency, the condenser must remain as free of these deposits as possible. Even a very thin layer on the inside tube surfaces reduces the heat transfer ability of the condenser. Indications of scale deposits are decreased water flow through the condenser, reduced temperature differential between entering and leaving condenser water and abnormally high condensing temperatures.

There are two accepted methods of cleaning condenser tubes, as discussed in the following paragraphs.

Mechanical Cleaning (RTWA)

The mechanical cleaning method is used primarily to remove sludge and other loose material from the condenser tubes. Follow the steps below:

1. Turn off the chiller and condenser water supply.
2. Break piping connections at the unions.
3. Remove the condenser waterboxes.
4. Run a round nylon brush from end to end through the tubes, to loosen deposits.
5. Flush the tubes with water. Then inspect the tubes for scale accumulation. If there is no scale in the tubes, reassemble the condenser and piping.
6. If there is scale in the tubes, follow the procedures in Paragraph ["Chemical Cleaning \(RTWA\)" on Page 138](#).



Maintenance

Chemical Cleaning (RTWA)

Chemical cleaning is the most satisfactory method of cleaning scale from the condenser. With this treatment, scale is dissolved and flushed away by circulating a chemical solution through the tubes and headers.

Internal condenser components are composed of copper, steel and cast iron. With this information, water treatment firms will be able to recommend a suitable chemical for this purpose. If water treatment is not available, consult a chemical supply house.

Figure 43 illustrates a typical chemical cleaning arrangement. All materials used in the chemical (external) circulating system, quantity of cleaning material, duration of cleaning and any safety precautions relative to the handling of the cleaning agent must be provided or approved by the supplier of the cleaning agent.

RTCA Coil Cleaning

⚠ WARNING

Hazardous Chemicals!

Coil cleaning agents can be either acidic or highly alkaline. Handle chemical carefully. Proper handling should include goggles or face shield, chemical resistant gloves, boots, apron or suit as required. For personal safety refer to the cleaning agent manufacturer's Materials Safety Data Sheet and follow all recommended safe handling practices. Failure to follow all safety instructions could result in death or serious injury.

Clean the condenser coils at least once each year, or more frequently if the unit is located in a "dirty" environment. This will maintain proper unit operating efficiencies. Follow the detergent manufacturer's instructions as closely as possible to avoid damage to the coils.

To clean the coils, use a soft brush and a sprayer, either a garden, pump-up type or a high-pressure type. A high-quality detergent, such as "Trane Coil Cleaner, CHM-0002" is recommended for standard and Copper coils. Refer to RTAC-SVG01B-EN for maintenance and cleaning procedures coated coil

NOTE: If the detergent mixture is strongly alkaline (pH value greater than 8.5), an inhibitor must be added.

Maintenance

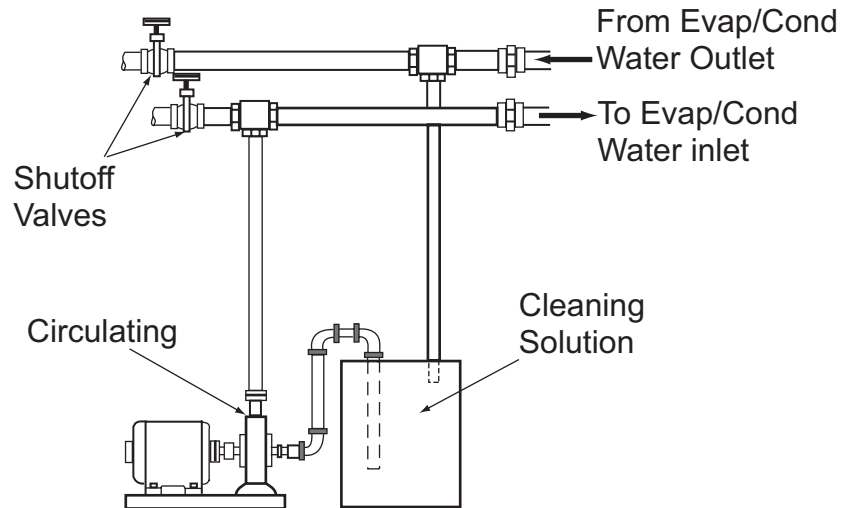

Figure 43 Chemical Cleaning Configuration

Water Treatment

The use of untreated or improperly treated water in the unit may result in the formation of scale, algae, or slime. It may also cause erosion or corrosion. It is recommended that a qualified water treatment specialist provide recommendations for proper water treatment.

CAUTION

Proper Water Treatment!

The use of untreated or improperly treated water in a RTAA may result in scaling, erosion, corrosion, algae or slime. It is recommended that the services of a qualified water treatment specialist be engaged to determine what water treatment, if any, is required. Trane assumes no responsibility for equipment failures which result from untreated or improperly treated water, or saline or brackish water.

Oil Separator Level Check

Follow the steps listed below and refer to the notes listed in [Figure 44](#).

1. Turn off the unit
2. Attach the hoses and sight glass to the oil separator charging Schrader valve and the compressor discharge service valve, as shown in [Figure 44](#). Remove non-condensibles.
3. After the unit has been off for 10 minutes, move the sight glass up and down until the level can be seen.
4. After the level has been determined, remove the sight glass and hoses.

Insure that the apex of the line above the sightglass is as high as possible, to eliminate liquid traps which can give erroneous readings.

Maintenance

Insure that the apex of the line above the sightglass is as high as possible, to eliminate liquid traps which can give erroneous readings.

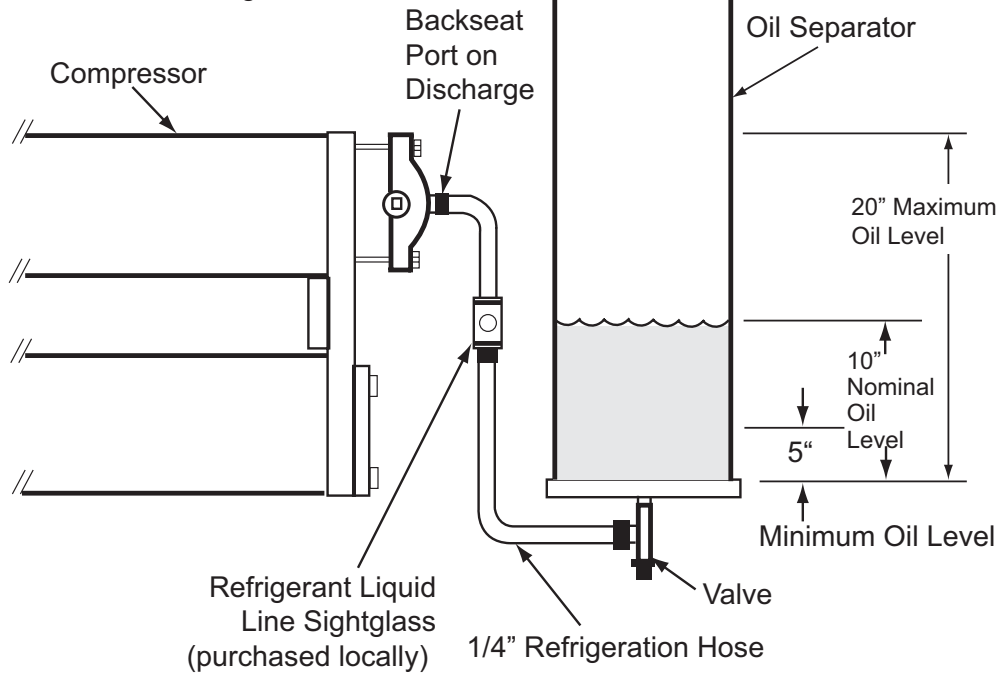

Figure 44 System Oil Level Specifications

Oil Filter Change

NOTE: Routine changing of the oil or the oil filter is not recommended. The oil filter is oversized for this application and should not require replacement.

The oil and filter should be replaced only if analysis reveals that the oil is contaminated. Oil type and system capacities are shown in [Table 1](#).

Pressure drops across the oil filter is shown in [Figure 46](#). Oil filter pressure drop is the difference between the pressure at the oil filter cover plate Schrader valve and the pressure at the compressor oil supply Schrader valve, on top of the compressor.

To change the oil filter in the unit, refer to [Figure 45](#) and follow the steps listed below.

1. Shut off the compressor and disconnect all electrical service to the compressor.
2. Connect manifold gauge sets to the backseat ports of the suction and discharge service valves and the Schrader valves on the oil filter cover plate.
3. Frontseat the suction and discharge service valves. Close the manual oil shutoff valve at the oil supply to the compressor.
4. Recover refrigerant from the three connections in Step 2.

NOTE: The Schrader valve may have a high quantity of oil.

Maintenance

⚠ WARNING

Components Under High Pressure!

Failure to relieve pressure before removing filter retaining bolt could result in death or serious injury

- Remove the seven bolts on the oil filter cover. A pan may be necessary to catch any oil that is released after the cover is loosened.

NOTE: Observe the placement of the copper gasket under one bolt head.

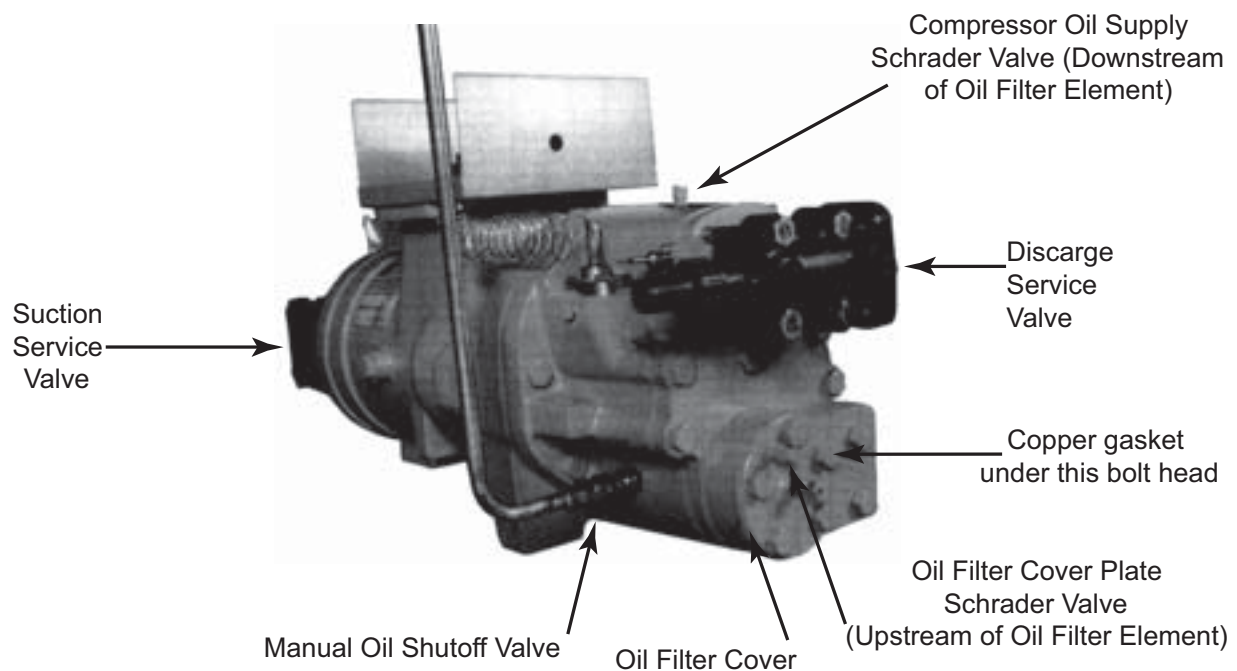

Figure 45 Oil Filter Change

- Remove the cover and oil filter element.
- Install the new filter element.
- Coat the new cover gasket with refrigerant oil.
- Install the cover plate and cover plate gasket.
- Install a new copper gasket under the bolt head that had one at time of removal. Replace all other bolts and tighten to 150 ft.lbs.
- Energize the three solenoid valves on the compressor by jumpering the proper terminals at the UCM.
- Evacuate to 400 microns from the three ports in Step 2 and perform a rise test.
- De-energize the three solenoid valves in Step 11.
- Open the manual oil shutoff valve that was closed in Step 3.

Maintenance

NOTE: Insure that this step is performed before Step 15, as this will insure that the oil filter housing is full of oil before the compressor is started.

- 15.** Backseat the suction and discharge service valves.
- 16.** Remove the manifold gauge set.

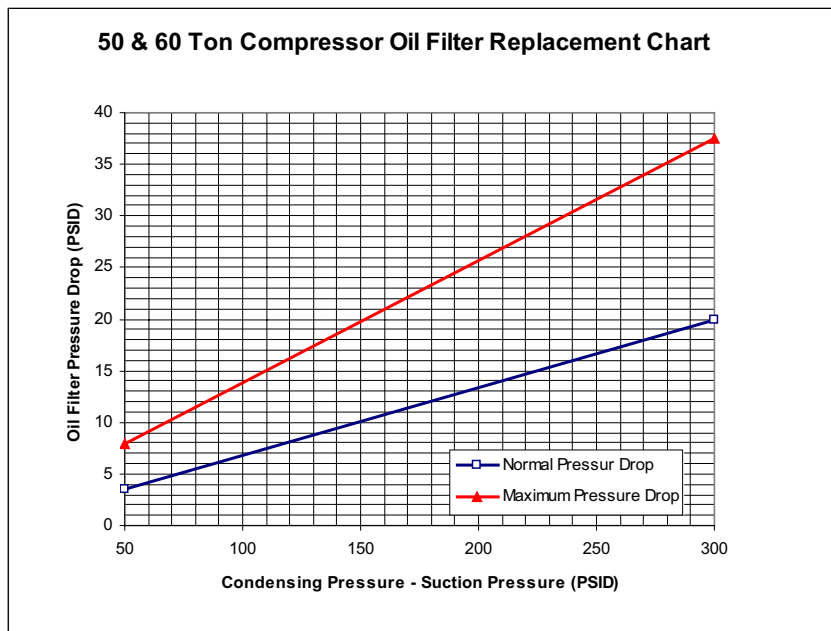
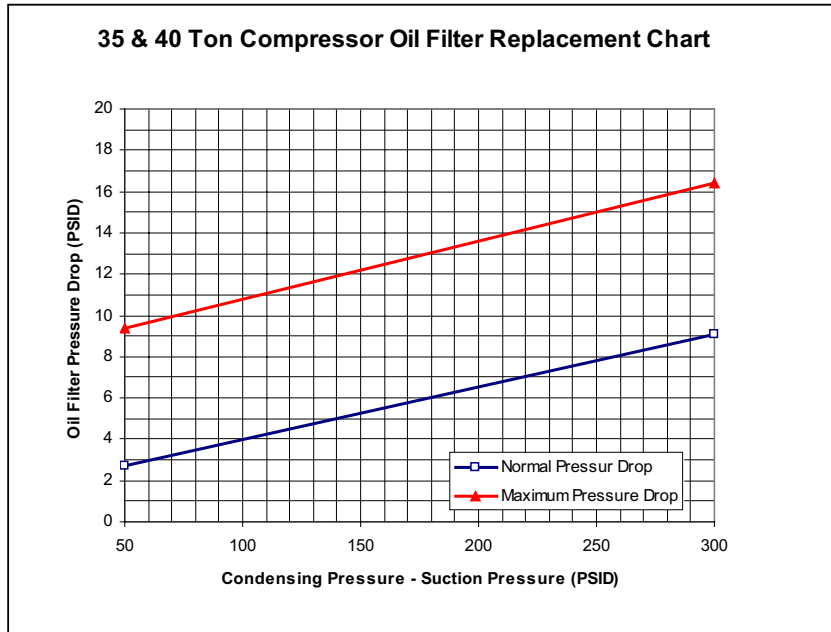

Figure 46 Oil Pressure Drop



Refrigerant Charging

If the refrigerant charge needs to be adjusted, be certain to monitor the subcooling and superheat measurements. The subcooling needs to be between 6 F and 8 F when the unit is running fully loaded. The ambient temperature is between 75 F and 100 F and the leaving water temperature is between 40 F and 55 F. The superheat needs to be close to or at the superheat setpoint entered in the UCM.

CAUTION: **Equipment Damage!**

The evaporator water flow must be established and maintained while adjusting the charge. Refrigerant pressures below 65 psig can cause freezing and rupturing of the evaporator tubes.

Adding Refrigerant

The RTWA 70-125 ton units are shipped with an entire charge of refrigerant and oil. The RTUA 70/125 ton units are shipped with a holding charge of nitrogen and the oil charge, excluding the additional oil charge needed for field piping. If the unit has no pressure, the system must be leak tested prior to adding refrigerant. Evacuate the system down to at least 100 microns prior to adding the refrigerant.

CAUTION: **Equipment Damage!**

Water must be flowing through the tube bundles during this entire process. Refrigerant pressures below 65 psig can cause freezing and rupturing of the heat exchangers.

1. Connect 115 VAC power to the master solenoid, the female load solenoid and the male load/unload solenoids. This must be done to evacuate all of the cavities in the compressor.
2. Open all service valves.
3. Connect hoses from the vacuum pump to the backseat ports on the suction line service valve and the discharge line service valve.
4. Evacuate the system to 100 microns and isolate the vacuum pump.
5. Confirm that no moisture or leaks are present by letting the vacuum stand for several minutes.
6. Add refrigerant gas to the system through the backseat port on the discharge service valve until the pressure is above 65 psig.

NOTE: Weigh in entire charge from [Table 1](#) (RTWA only) and Paragraph "[Remote Air-Cooled Condenser Interconnecting Refrigerant Piping](#)" on [Page 45](#) (RTUA and RTCA units).

7. Once the pressure exceeds 65 psig, add liquid refrigerant through the 1/4 inch service valve between the EXV and the evaporator.
8. The unit may need to be started to add the entire charge. Once the unit is started, monitor the subcooling and superheat to trim the charge.



Refrigerant Charging

CAUTION

Equipment Damage!

The evaporator water flow must be established and maintained while adjusting the charge. Refrigerant pressures below 65 psig can cause freezing and rupturing of the evaporator tubes.

Low Side Repairs

If the refrigerant charge needs to be isolated in the high side of the unit, perform the following procedures:

1. Press the STOP key and send the unit through a stopping mode.
2. Place a manifold gauge set on the backseat port of the liquid line service valve before actually closing the valve.
3. Close the liquid line service valve.
4. While the unit is in the STOP mode, enable Service Pumpdown for the specific compressor. Service Pumpdown is found under the Service Tests menu.

NOTE: Service Pumpdown can only be enabled for one compressor at a time. Only one pumpdown per compressor can be performed, until the unit has been reset. If these requirements are not met and Service Pumpdown is enabled, the screen will display "PROHIBITED" for one second and then return to disable.

With Service Pumpdown enabled, the Restart Inhibit will be ignored, the EXV will be prepositioned and the selected compressor will start and run for one minute.

5. Once the compressor stops, close the discharge service valve on the compressor.
6. The remaining refrigerant needs to be recovered from the suction service valve and the liquid line Schrader valve. Attach the inlet of a recovery system to the backseat port on the suction service valve and the Schrader valve between the liquid line service valve and the filter drier. Attach the outlet of the recovery system to the manifold gauge set that is already attached to the access port on the liquid line service valve. The condenser will be used as the storage vessel.
7. Complete all necessary repairs.
8. Evacuate out of the backseat port on the suction service valve and from the Schrader valve between the liquid line service valve and the filter drier.
9. Break the vacuum by adding refrigerant to the service port on the suction valve.
10. Open all valves, start the unit and verify the refrigerant charge by measuring the subcooling.

High Side Repair

If the refrigerant needs to be isolated in the low side of the unit, perform the following procedures:

1. Press the STOP key and send the unit through a stopping mode.



Refrigerant Charging

2. Close the discharge service valve.
3. Before closing the liquid line service valve, attach a manifold gauge set to the liquid line valve backseat port.
4. Close the liquid line service valve.
5. Attach the inlet of a liquid transfer pump to the manifold gauge set and the outlet to the 1/4" angle valve, located between the EXV and the evaporator. This will transfer the liquid refrigerant.
6. Remove the liquid transfer pump. Attach the inlet of a recovery system to the manifold gauge set and the outlet to the 1/4" angle valve, located between the EXV and the evaporator. Remove all of the vapor from the high side of the system.
7. Complete all necessary repairs.
8. Evacuate the high side through the access port on the liquid line service valve that has the manifold gauge set attached to it.
9. Open all of the valves and run the unit. Verify the refrigerant charge by measuring the subcooling and monitor the sightglass.



Diagnostics

In the table below, a latching diagnostic is a condition which shall cause the machine or a portion of the machine as noted to shut down and shall require a manual reset to restore operation. A diagnostic that is non-latching shall reset automatically when the condition causing the diagnostic goes away. A non-latching diagnostic shall shut down the machine or a part of the machine if so indicated. If a diagnostic is informative only, no machine or circuit action is taken except to load a diagnostic code into the last diagnostic register.

Diagnostic Types (And Action)

- MMR = Machine Shutdown, Manual Reset
- MAR = Machine Shutdown, Auto Reset
- CMR = Circuit Shutdown, Manual Reset
- CAR = Circuit Shutdown, Auto Reset
- IFW = Information Warning

Table 28 Diagnostic Codes

Diagnostic Description	Type	Cause
Chilled Water Flow (Ent Wtr Temp)	MMR	<ul style="list-style-type: none"> a. The entering evaporator water temp. fell below the leaving evaporator water temp. by more than 2F for 100 degree F - seconds. b. Causes to trip this diagnostic include either a loss of chilled water flow or a calibration shift in the evap. water temp. sensors.
Chilled Water Flow Interlock	MAR	The chilled water flow switch input was open for more than 6 seconds.
Compressor Overload Setting Cprsr A	IFW	The CPM NovRam Based overload setting did not agree with the MCSP Dip Switch overload setting for 30 contiguous seconds. The affected MCSP shall use the minimum (00000 binary, 00 decimal) overload setting as a default until the UCM is reset when this diagnostic occurs.
Compressor Overload Setting - Cprsr B	I FW	Same as Cprsr A, above.
Compressor Overload Setting - Cprsr C	IFW	Same as Cprsr A, above.
Compressor Overload Setting - Cprsr D	IFW	Same as Cprsr A, above.
Cond Fan Var Speed Drive Fault Ckt 1	IFW	The controlling MCSP for the given circuit has unsuccessfully attempted (5 times within 1 minute) to clear a fault signal from the Condenser Fan Inverter Drive. The 5th attempt removes power from the inverter to create a power up reset. If the fault does not clear, the UCM will revert to constant speed operation without the use of the inverters fan. The inverter must be manually bypassed for full fixed speed fan operation.
Cond Fan Var Speed Drive Fault Ckt 2	IFW	Same as Ckt 1, above.
Cond Entering Wtr Temp Sensor	IFW	Shorted Cond. temp sensor. No diagnostic on open.
Cond Leaving Wtr Temp Sensor	IFW	Shorted Cond. temp sensor. No diagnostic on open.
Cond Rfgt Temp Sensor - CKT 1	CMR	Open or short.
Cond Rfgt Temp Sensor - CKT 2	CMR	Open or short.

Diagnostics

Table 28 Diagnostic Codes

Diagnostic Description	Type	Cause
Contactors CPRSR A	MMR	a. Welded cprsr contactor. b. Detected a welded compressor contactor when the compressor was commanded off but the current does not go to zero. Detection time shall be 5 second minimum and 10 seconds maximum. On detection, generate the diagnostic, energize the appropriate alarm relay, continue to command the affected compressor off, energize the affected compressors oil line solenoid, stop all other compressors, unload the running compressor with the welded contactor, open the EXV to its maximum open position, and continue to do fan control. Do not exit this condition until the controller is manually reset.
Contactors CPRSR B	MMR	Same as CPRSR A.
Contactors CPRSR C	MMR	Same as CPRSR A.
Contactors CPRSR D	MMR	Same as CPRSR A.
CPRSR Suct Temp Sensor - Ckt 1	CMR	Open or short.
CPRSR Suct Temp Sensor - Ckt 2	CMR	Open or short.
CWS/Leaving Water Temp Cutout Setpoint Overlap	None	No diagnostic, display to flash and limit value to last legal value.
<p><i>NOTE: The above is not a diagnostic because you don't want the display vectoring you to a different display state when you are trying to set either the chilled water setpoint or the leaving water temp. cutout setpoint as it will in the case of a diagnostic.</i></p>		
Discharge Temp - Cprsr A	CMR	a. The discharge temp. exceeded the trip value; 135 + or -3 C. b. The discharge temp. PTC or wiring is open. c. Time to trip from either trip value exceeded or input open shall be 0.5 to 2.0 seconds.
Discharge Temp - Cprsr B	CMR	Same as Diagnostic for Cprsr A, above.
Discharge Temp - Cprsr C	CMR	Same as Diagnostic for Cprsr A, above.
Discharge Temp - Cprsr D	CMR	Same as Diagnostic for Cprsr A, above.
Emergency Stop	MMR	EMERGENCY STOP input is open. An external interlock has tripped. Time to trip from input opening to unit stop shall be 0.1 to 1.0 seconds.
Entering Oil Temp Sensor - Cprsr A	CMR	Open or short.
Entering Oil Temp Sensor - Cprsr B	CMR	Open or short.
Entering Oil Temp Sensor - Cprsr C	CMR	Open or short.
Entering Oil Temp Sensor - Cprsr D	CMR	Open or short.
Evap Entering Wtr Temp Sensor	MMR	Open or short.
Evap Leaving Wtr Temp Sensor	MMR	Open or short.
Evap Rfgr Temp Sensor - CKT 1	CMR	Open or short (for 30 sec).
Evap Rfgr Temp Sensor - CKT 2	CMR	Open or short (for 30 sec).



Diagnostics

Table 28 Diagnostic Codes

Diagnostic Description	Type	Cause
External Chilled Water Setpoint	IFW	a. Not "Enabled": no diagnostics. b. "Enabled": Out-Of-Range Low, set diagnostic. Out-Of-Range Hi, no diagnostic.
External Current Limit Setpoint	IFW	a. Not "Enabled": no diagnostics. b. "Enabled": Out-Of-Range Low, set diagnostic. Out-Of-Range Hi, no diagnostic.
EXV Elec. Drive CKT - Rfgt Ckt 1	CMR	Run the EXV electrical drive circuit test both on demand from the human interface and just before either a circuit or one of a pair of circuits starts.
EXV Elec. Drive CKT - Rfgt Ckt 2	CMR	Same as Diagnostic for Ckt 1, above.
High Diff. Press. - Ckt 1	CMR	The difference between the Condenser pressure and the evaporator pressure exceeded 350 PSID for 0.8-5.0 seconds. 320 PSID must hold, 320 + to trip in One Hour.
High Diff. Press - Ckt 2	CMR	Same as Diagnostic for Ckt 1, above.
High Oil Temp - Cprsr A	CMR	Entering Oil Temp to given compressor exceeded 170F. Time to trip is given by equation: trip time = (190-Oil Temp) x 180 sec/F.
High Oil Temp - Cprsr B	CMR	Same as Cprsr A, above.
High Oil Temp - Cprsr C	CMR	Same as Cprsr A, above.
High Oil Temp - Cprsr D	CMR	Same as Cprsr A, above.
High Pressure Cutout - Cprsr A	CMR	A high pressure cutout was detected on Cprsr A; trip at 405 + or -7 PSIG.
High Pressure Cutout - Cprsr B	CMR	A high pressure cutout was detected on Cprsr B; trip at 405 + or -7 PSIG.
High Pressure Cutout - Cprsr C	CMR	A high pressure cutout was detected on Cprsr C; trip at 405 + or -7 PSIG.
High Pressure Cutout - Cprsr D	CMR	A high pressure cutout was detected on Cprsr 0; trip at 405 + or -7 PSIG.
Loss of Local Display Panel COM	IFW	The 1U1 has detected a loss of IPC communication with the Local Display panel for at least 15 seconds.
Low Chilled Water Temp (Unit off)	IFW	The chilled water temp. fell below the cutout setpoint while the compressors were not running.
Low Chilled Water Temp (Unit on)	MAR	The chilled water temp. fell below the cutout setpoint while the compressors were running for 30 degree F Seconds.
Low Differential Press - Ckt 1	CMR	The fan control algorithm detected a low differential Temperature/Pressure condition that existed for more than 180 contiguous seconds. Trip point is 40 PSID.
Low Differential Press - Ckt 2	CMR	Same as Diagnostic for Ckt 1, above.
Low Evap Rfgt Temp - Ckt 1	CMR	a. The Saturated Evap Rfgt Temp - Circuit 1 dropped below the Low Rfgt Temp Cutout Setpoint while the circuit was running for 30 deg F seconds. b. See the low ambient ignore time on startup.
Low Evap Rfgt Temp - Ckt 2	CMR	Same as Diagnostic for Ckt 1, above.

Diagnostics

Table 28 Diagnostic Codes

Diagnostic Description	Type	Cause
Low Oil Flow - Cprsr A	CMR	The differential oil pressure switch remained opened for more than 20 contiguous seconds on Cprsr A. Note: Although GP cmprs do not have pressure switch or Oil Line solenoid, this diagnostic is still active. The input must be jumpered for normal operation on GP cmprs.
Low Oil Flow - Cprsr B	CMR	Same as Diagnostic for Cprsr A, above, but Cprsr B.
Low Oil Flow - Cprsr C	CMR	Same as Diagnostic for Cprsr A, above, but Cprsr C.
Low Oil Flow - Cprsr D	CMR	Same as Diagnostic for Cprsr A, above, but Cprsr D.
Low Pressure Cutout - Ckt 1	CMR	The low pressure switch opened or remained open past the ignore time during compressor operation (after one retry) or the low pressure switch was open prior to compressor start with Sat Cond Temp above -18F.
Low Pressure Cutout - Ckt 2	CMR	Same as Ckt 1.
Low Superheat - Ckt 1	CMR	A low superheat condition existed for an extended period of time. If a superheat less than or equal to 2 degrees F (1.11 degrees C) is detected for more than 2400 degree F seconds, the circuit shall be shutdown. The integrated area (2400 Degree F seconds) shall be only below 2 degrees F superheat.
Low Superheat - Ckt 2	CMR	Same as Diagnostic for Ckt 1, above.
Memory Error Type I	IFW	On UCM either power up or following a Type II Memory Error a NOVRAM memory error was detected. The UCM is operating on all Engineering ROM defaults for all setup parameters. Check all setup parameters and continue to run chiller. Replace the Chiller Module as soon as a replacement is available. <i>NOTE: It is expected that this diagnostic will be detected on the very first power up of the Chiller Module at the Manufacturer since the NOVRAM will not contain valid data on first power up.</i>
Memory Error Type II	IFW	A Shadow RAM memory error was detected. The UCM is operating on all last valid values (pulled from NOVRAM) for all setup parameters. No setup parameter changes were pending to be loaded into NOVRAM, a complete recovery of all setup parameters was made and there is no need to check unit setup parameters. Compressor starts and hour were lost for not more than the last 24 hours. This is expected to be an isolated event and repair or replacement is not required. If this diagnostic does occur repeatedly, then replace the Chiller module.
Memory Error Type III	IFW	A Shadow RAM memory error was detected. The UCM is operating on all last valid values (pulled from NOVRAM) for all setup parameters. Setup parameter changes less than 24 hours old pending to be loaded into NOVRAM were lost. Check all setup parameters made in the last 24 hours. Compressor starts and hours were lost for not more than the last 24 hours. This is expected to be an isolated event and repair or replacement is not required. If this diagnostic does occur repeatedly, then replace the Chiller module.



Diagnosics

Table 28 Diagnostic Codes

Diagnostic Description	Type	Cause
Oil System Fault - Ckt 1	CMR	Entering Oil Temp on either compressor of the given circuit reads a temperature x degrees below the given ckts' saturated condenser temperature for more than 30 minutes where x is the Oil Loss Differential Setpoint (2 degree F hysteresis to clear timer).
Oil System Fault - Ckt 2	CMR	Same as for Ckt 1, above.
Outdoor Air Temp Sensor (Both Outdoor Air Reset and Low Ambient Lockout not selected)	None	Open or short. a. Display dashes e.g. "14---
Outdoor Air Temp Sensor (Either Outdoor Air Reset or Low Ambient Lockout selected.)	I FW	Open or short. a. Use end of range value (whatever value the open or short. b. Clear diag. when the resistance returns to normal range.
Over Voltage	MAR	Line voltage above + 10% of nominal. (Must hold = + 10% of nominal. Must trip = + 15% of nominal. Reset differential = min. of 2% and max. of 4%. Time to trip = minimum of 10 sec. and maximum of 20 seconds.) Design: Nom. trip: 15 seconds at greater than 113.5%, ± 2.8% at 200V, or ± 1.8% at 575V, Auto reset at 110.5% or less.
Overload Trip - CPRSR A	CMR	Cprsr current exceeded overload time vs. trip characteristic.
Overload Trip - CPRSR B	CMR	Same as Diagnostic for Cprsr A.
Overload Trip - CPRSR C	CMR	Same as Diagnostic for Cprsr A.
Overload Trip - CPRSR D	CMR	Same as Diagnostic for Cprsr A.
Phase Loss - Cprsr A	CMR	No current was sensed on one or more of the current x former inputs. (Must hold = 20% RLA. Must trip = 5% RLA.) Time to trip shall be 1 second minimum, 3 seconds maximum.
Phase Loss - Cprsr B	CMR	Same as Diagnostic for Cprsr A, above.
Phase Loss - Cprsr C	CMR	Same as Diagnostic for Cprsr A, above.
Phase Loss - Cprsr D	CMR	Same as Diagnostic for Cprsr A, above.
Phase Reversal - Cprsr A	CMR	A phase reversal was detected on the incoming current. On a compressor startup the phase reversal logic must detect and trip in a maximum of 1.0 second from compressor start.
Phase Reversal - Cprsr B	CMR	Same as Diagnostic for Cprsr A, above.
Phase Reversal - Cprsr C	CMR	Same as Diagnostic for Cprsr A, above.
Phase Reversal - Cprsr D	CMR	Same as Diagnostic for Cprsr A, above.
Phase Rev Prot Lost Cprsr A	CMR	The phase reversal protection on compressor A has become inoperative. The phase rotation protection system failed to detect 2 in a row of one of the four phase circuit states: Phase reversal, Phase rotation OK, Phase A lost., Phase B lost.
Phase Rev Prot Lost - Cprsr B	CMR	Same as Cprsr A, above, but Cprsr B.
Phase Rev Prot Lost - Cprsr C	CMR	Same as Cprsr A, above, but Cprsr C.
Phase Rev Prot Lost - Cprsr D	CMR	Same as Cprsr A, above, but Cprsr D.
Phase Unbalance - Cprsr A	CMR	A 15% phase unbalance condition has been detected.
Phase Unbalance - Cprsr B	CMR	Same as Diagnostic for Cprsr A.
Phase Unbalance - Cprsr C	CMR	Same as Diagnostic for Cprsr A.

Diagnostics

Table 28 Diagnostic Codes

Diagnostic Description	Type	Cause
Phase Unbalance - Cprsr D	CMR	Same as Diagnostic for Cprsr A.
Power Loss - Cprsr A	CAR	<ul style="list-style-type: none"> a. The Cprsr was running and all three phases of current were lost. b. There was an open Transition input after transition had been previously proven to have been complete. c. There was an incomplete Transition on the first check after transition and all three phases of current were not present.
Power Loss - Cprsr B	CAR	Same as Diagnostic for Cprsr A, above.
Power Loss - Cprsr C	CAR	Same as Diagnostic for Cprsr A, above.
Power Loss - Cprsr D	CAR	Same as Diagnostic for Cprsr A, above.
Severe Phase Unbalance - Cprsr A	CMR	A 30% Phase Unbalance diagnostic has been detected. The 15% Phase Unbalance criteria has been defeated. Items to check are the Current Transformer Part Numbers (they should all match). The current Transformer resistances, line voltage phase balance, all power wiring connections, the contactor pole faces, and the motor. If all these are OK, replace the MCSP module of the affected circuit.
Severe Phase Unbalance - Cprsr B	CMR	Same as Diagnostic for Cprsr A, above.
Severe Phase Unbalance - Cprsr C	CMR	Same as Diagnostic for Cprsr A, above.
Severe Phase Unbalance - Cprsr D	CMR	Same as Diagnostic for Cprsr A, above.
Slaved EXV E1ec Drive CKT - Rfgt Ckt 1	CMR	Run the EXV electrical drive circuit test both on demand from the human interface and just before either a circuit or one of a pair of circuits starts.
Slaved EXV Elec Drive CKT -	CMR	Same as Diagnostic for Ckt 1, above.
Starter Transition - Cprsr A	CMR	<ul style="list-style-type: none"> a. The UCM did not receive a transition complete signal in the designated time from the UCM command to transition. The must hold time from the UCM transition command is 1 second. The Must trip time from the transition command is 6 seconds. b. The Transition Complete input was found to be shorted before the compressor was started. c. Active only if Reduced Inrush Starting is Enabled.
Starter Transition - Cprsr B	CMR	Same as Diagnostic for Cprsr A, above.
Starter Transition - Cprsr C	CMR	Same as Diagnostic for Cprsr A, above.
Starter Transition - Cprsr D	CMR	Same as Diagnostic for Cprsr A, above.
Subcooled Liquid Temp Sensor - Ckt 1	IFW	Open or short.
Subcooled Liquid Temp Sensor - Ckt 2	IFW	Open or short.



Diagnostics

Table 28 Diagnostic Codes

Diagnostic Description	Type	Cause
Tracer Communications Loss	IFW	a. While the chiller switch was in AUTO/REMOTE the communications between the CSR and the connected remote device, e.g., a Tracer or Remote Display, had either never been established for more than 15 minutes after power up or had been lost for more than 15 minutes after it had been established; use the Front Panel Setpoints and the Default Chiller Auto/Stop. b. In AUTO/LOCAL communications had been established and was then lost for more than 15 minutes. Regardless of the remote communications status the UCM uses Front Panel setpoints.
<i>NOTE: The active modes for this diagnostic follow the positions of the chiller switch which account for other chiller modes.</i>		
Under Voltage	MAR	Line voltage below - 10% of nominal or the Under/Over transformer is not connected. (Must hold = -10% of nominal. Must trip = -15% of nominal. Reset differential = min. of 2% and max. of 4%. Time to trip = min. of 10 sec. and max. of 20 sec.) Design: Nom. trip: 15 seconds at less than 87.5%. ± 2.8% at 200V. or ± 1.8% at 575V, Auto reset at 90.5% or greater.
U1 Indicating U2 Communications	IFW	The 1U1 has det. a loss of IPC comm from the 1U2 module.
U1 Indicating U3 Communications	MMR	The 1U1 has det. a loss of IPC comm from the 1U3 module.
U1 Indicating U4 Communications	CMR	The 1U1 has det. a loss of IPC comm from the 1U4 module.
U1 Indicating U5 Communications	CMR	The 1U1 has det. a loss of IPC comm from the 1U5 module.
U1 Indicating U6 Communications	CMR	The 1U1 has det. a loss of IPC comm from the 1U6 module.
U1 Indicating U7 Communications	CMR	The 1U1 has det. a loss of IPC comm from the 1U7 module.
U3 Indicating U1 Communications	MMR	The 1U3 has det. a loss of IPC comm from the 1U1 module.
U3 Indicating U4 Communications	CMR	The 1U3 has det. a loss of IPC comm from the 1U4 module.
U3 Indicating U5 Communications	CMR	The 1U3 has det. a loss of IPC comm from the 1U5 module.
U3 Indicating U6 Communications	CMR	The 1U3 has det. a loss of IPC comm from the 1U6 module.
U3 Indicating U7 Communications	CMR	The 1U3 has det. a loss of IPC comm from the 1U7 module.
U4 Indicating U1 Communications	CMR	The 1U4 has det. a loss of IPC comm from the 1U1 module.
U4 Indicating U3 Communications	CMR	The 1U4 has det. a loss of IPC comm from the 1U3 module.
U4 Indicating U5 Communications	CMR	The 1U4 has det. a loss of IPC comm from the 1U5 module.
U5 Indicating U1 Communications	CMR	The 1U5 has det. a loss of IPC corn from the 1U1 module.
U5 Indicating U3 Communications	CMR	The 1U5 has det. a loss of IPC corn from the 1U3 module.
U5 Indicating U4 Communications	CMR	The 1U5 has det. a loss of IPC comm from the 1U4 module.
U6 Indicating U1 Communications	CMR	The 1U6 has det. a loss of IPC comm from the 1U1 module.
U6 Indicating U3 Communications	CMR	The 1U6 has det. a loss of IPC comm from the 1U3 module.
U6 Indicating U7 Communications	CMR	The 1U6 has det. a loss of IPC comm from the 1U7 module.
Winding Temp - Cprsr A	CMR	a. The motor winding temperature thermostat opened; nominally 221 F. b. The motor temp. thermostat or wiring is open. c. Time to trip from input open to compressor shutdown shall be 0.5 to 2.0 seconds.

Diagnostics

Table 28 Diagnostic Codes

Diagnostic Description	Type	Cause
Winding Temp - Cprsr B	CMR	Same as Diagnostic for Cprsr A, above.
Winding Temp - Cprsr C	CMR	Same as Diagnostic for Cprsr A, above.
Winding Temp - Cprsr D	CMR	Same as Diagnostic for Cprsr A, above.
Zone Temp Sensor (Zone Reset Selected)	IFW	Open or Short. a. Use end of range value (whatever value the open or short gives). b. Clear diag. when the resistance returns to normal range. c. If Shorted, go into the ice making mode if "Ice Machine Control" is enabled.
Zone Temp Sensor (Zone Reset not Selected)	None	a. If Open, do normal chiller control. b. If Shorted, go into the ice making mode if "Ice Machine Control " is enabled.



Diagnostics

Unit Wiring

Typical field connection diagrams, electrical schematics and connection diagrams for 70-125 Ton RTWA, RTUA and RTCA units.

NOTE: The typical wiring diagrams in this manual are representative of “X0” design sequence units and are provided only for general reference. These diagrams may not reflect the actual wiring of your unit. For specific electrical connection and schematic information, always refer to the wiring diagrams which were shipped with your unit.

Unit Wiring

To determine the specific electrical characteristics of a particular chiller, always refer to the nameplates mounted on the unit. See [Figure 1](#).

Table 29 Legend

Drawing Number	Description	Page
RTWA		
2307-3332	Schematic Page 1	page 156
2307-3333	Schematic Page 2	page 158
2307-3334	Schematic Page 3	page 160
2307-3335	Schematic Page 4	page 162
2307-3336	Field Wiring Diagram	page 164
2307-5119	Component Location Diagram	page 166
RTUA		
2307-5143	Schematic Page 1	page 168
2307-5144	Schematic Page 2	page 170
2307-5145	Schematic Page 3	page 172
2307-5146	Schematic Page 4	page 174
2307-6008	Field Wiring Diagram	page 176
2307-6009	Component Location Diagram	page 178
RTCA		
2307-5147	Schematic Page 1	page 180
2307-6526	Schematic Page 2	page 182
2307-5150	Field Wiring Diagram	page 184
2307-6010	Component Location Diagram	page 186

CAUTION
 USE COPPER CONDUCTORS ONLY!
 UNIT TERMINALS ARE NOT DESIGNED TO ACCEPT
 OTHER TYPES OF CONDUCTORS.
 FAILURE TO DO SO MAY CAUSE DAMAGE TO THE
 EQUIPMENT.

ATTENTION
 N'UTILISER QUE DES CONDUCTEURS EN CUIVRE!
 LES BORNES DE L'UNITÉ NE SONT PAS CONÇUES
 POUR RECEVOIR D'AUTRES TYPES DE CONDUCTEURS.
 L'UTILISATION DE TOUT AUTRE CONDUCTEUR PEUT
 ENDOMMAGER L'ÉQUIPEMENT.

PRECAUCIÓN
 ÚTILICE ÚNICAMENTE CONDUCTORES DE COBRE!
 LAS TERMINALES DE LA UNIDAD NO ESTÁN DISEÑADAS
 PARA ACEPTAR OTROS TIPOS DE CONDUCTORES.
 SI NO LO HACE, PUEDE OCASIONAR DAÑO AL EQUIPO.

WARNING
 HAZARDOUS VOLTAGE!
 DISCONNECT ALL ELECTRIC POWER
 INCLUDING REMOTE DISCONNECTS
 AND FOLLOW LOCK OUT AND TAG
 PROCEDURES BEFORE SERVICING.
 CAPACITORS HAVE DISCHARGED
 VARIABLE VOLTAGE. UNITS WITH
 STORAGE SPEED DRIVE, REFER
 TO THE SERVICE MANUALS FOR
 CAPACITOR DISCHARGE
 FAILURE TO DO THE ABOVE
 BEFORE SERVICING COULD RESULT
 IN DEATH OR SERIOUS INJURY.

AVERTISSEMENT
 TENSION DANGEREUSE!
 COUPER TOUTES LES TENSIONS ET
 OUVRIER LES SECTIONNEURS À DISTANCE
 PUIS SUIVRE LES PROCÉDURES DE
 VERROUILLAGE ET DES ÉTIQUETTES AVANT
 LES RÉPARATIONS.
 LES CONDENSATEURS DES MOTEURS SONT
 DÉCHARGÉS. DANS LE CAS D'UNITÉS
 COMPORTANT DES ENTRAÎNEMENTS À
 VITESSE VARIABLE, CONSULTER LES
 INSTRUCTIONS DE L'ENTRAÎNEMENT POUR
 DÉCHARGER LES CONDENSATEURS.
 NE PAS RESPECTER CES MESURES DE
 PRÉCAUTION PEUT ENTRAÎNER DES
 BLESSURES GRAVES POUVANT ÊTRE
 MORTELLES.

ADVERTENCIA
 ¡VOLTAJE PELIGROSO!
 DESCONECTE TODA LA ENERGÍA ELÉCTRICA,
 INCLUIDO LAS DESCONECCIONES REMOTAS Y
 SIGA LOS PROCEDIMIENTOS DE CIERRE Y
 ETIQUETADO ANTES DE PROCEDER AL
 SERVICIO.
 LOS CONDENSADORES DEL MOTOR HAYAN
 DESCARGADO EL VOLTAJE ALMACENADO.
 PARA LAS UNIDADES CON EJE DE
 VELOCIDAD VARIABLE, CONSULTE LAS
 INSTRUCCIONES PARA LA
 DESCARGA DEL CONDENSADOR.
 EL NO REALIZAR LO ANTERIORMENTE
 INDICADO, PODRÍA OCASIONAR LA MUERTE
 O SERIAS LESIONES PERSONALES.

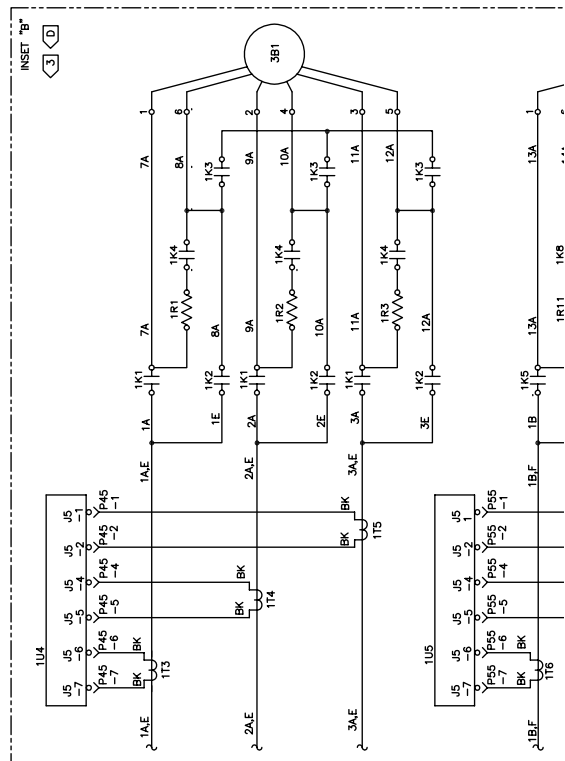
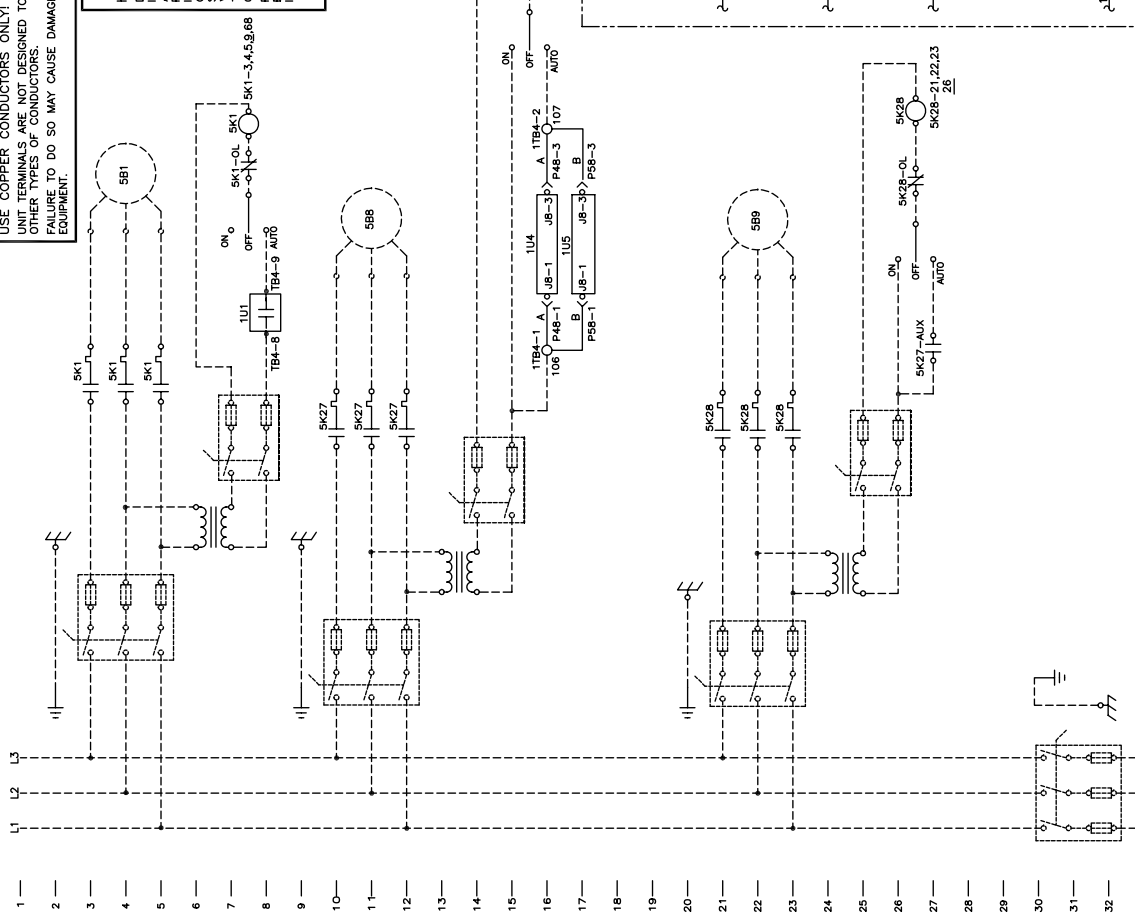

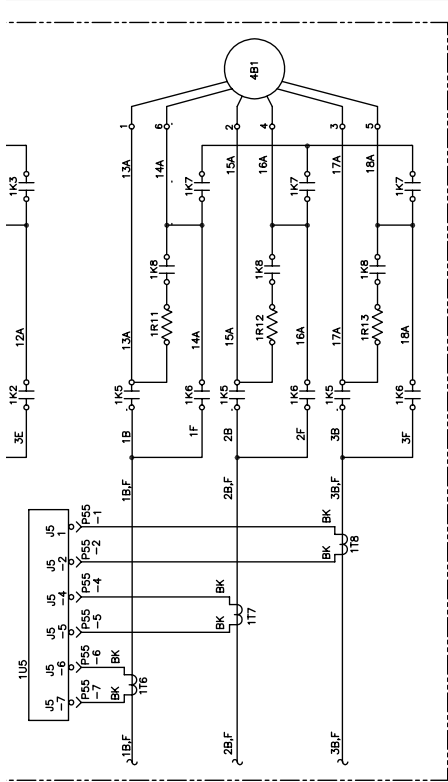

REVISED	2D CAD	REV NUMBER	2307-3332	REV	E
REVISION DATE	11-4-93	THE TRANE COMPANY A DIVISION OF AMERICAN STANDARD INC.	HELIICAL ROTOR HERMETIC LIQUID CHILLER SERIES "R" WATER COOLED CHILLER SCHEMATIC WIRING RTWA 70-125 TON	PAGE 1	
DESIGNED BY	SH	DATE OR TO			
1-20-93					

- NOTES:
- THE FOLLOWING CAPABILITIES ARE OPTIONAL. THE FOLLOWING CONFIGURATIONS MAY VARY BY UNIT VOLTAGE AND STARTER MANUFACTURER. THEY ARE IMPLEMENTED AS REQUIRED FOR A SPECIFIC SYSTEM APPLICATION.
 - (H) UNIT DISCONNECT, NON-FUSED
 - (D) WYE-DELTA CLOSED TRANSITION STARTER
 - (3) SEE INSET "B" FOR WYE-DELTA CLOSED TRANSITION STARTER WIRING
 - SEE ALSO STANDARD NOTES ON LEGEND DIAGRAM.

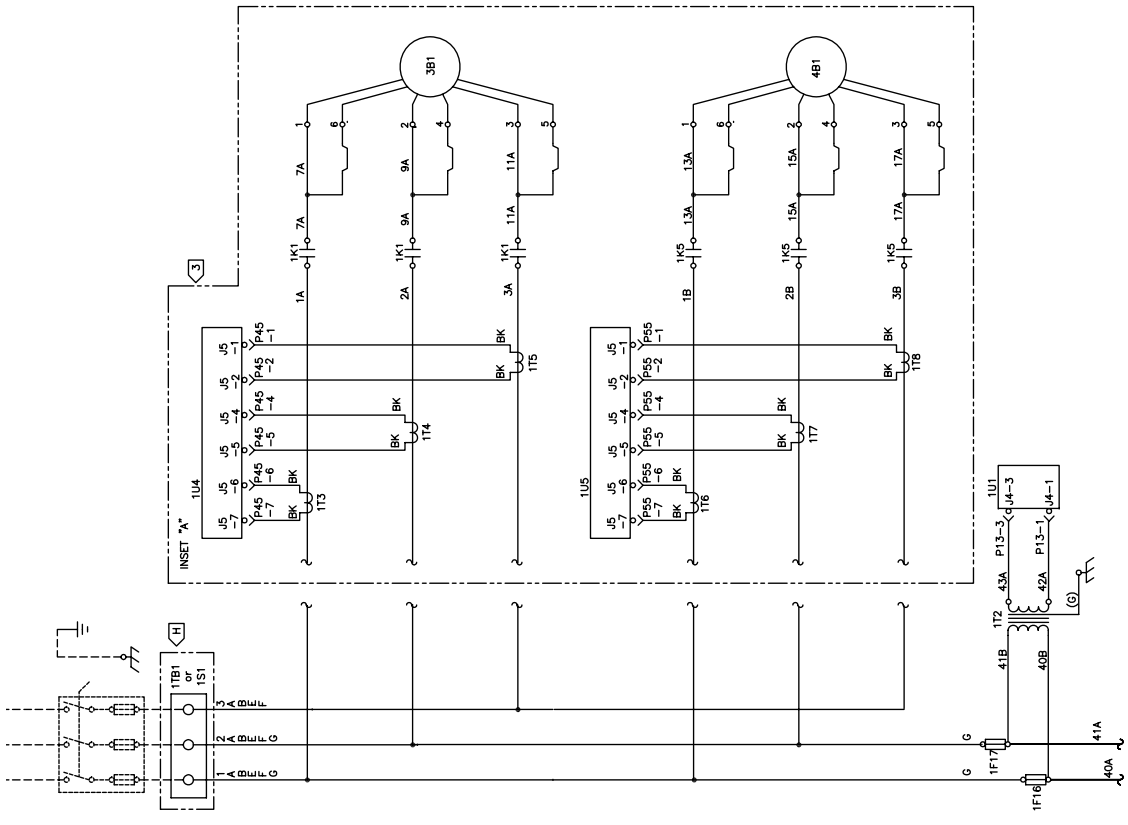

- 28
- 30
- 31
- 32
- 33
- 34
- 35
- 36
- 37
- 38
- 39
- 40
- 41
- 42
- 43
- 44
- 45
- 46
- 47
- 48
- 49
- 50
- 51
- 52
- 53
- 54
- 55
- 56
- 57
- 58
- 59
- 60

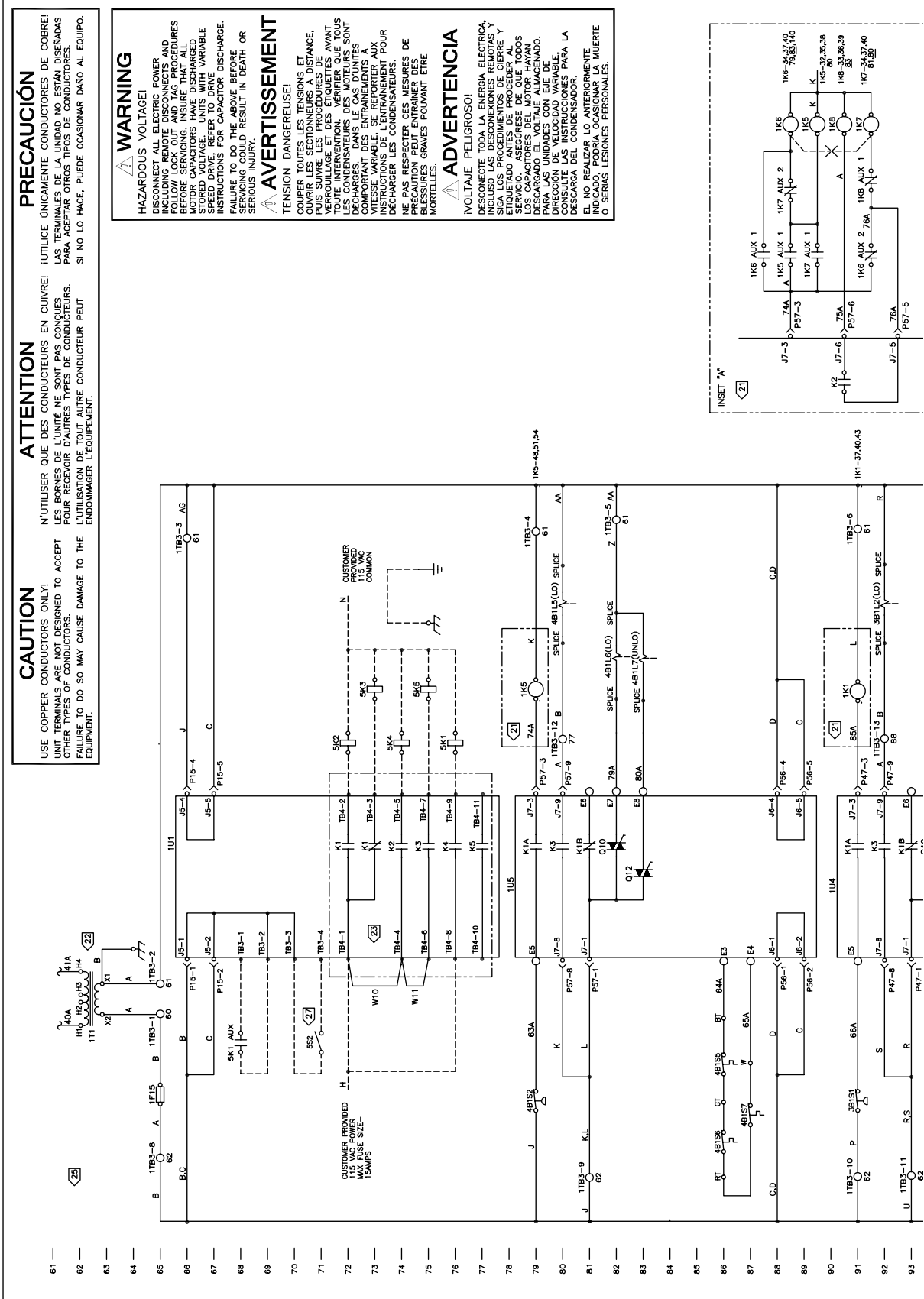

61 —
62 —
63 —
64 —
65 —
66 —
67 —
68 —
69 —
70 —
71 —
72 —
73 —
74 —
75 —
76 —
77 —
78 —
79 —
80 —
81 —
82 —
83 —
84 —
85 —
86 —
87 —
88 —
89 —
90 —
91 —
92 —
93 —

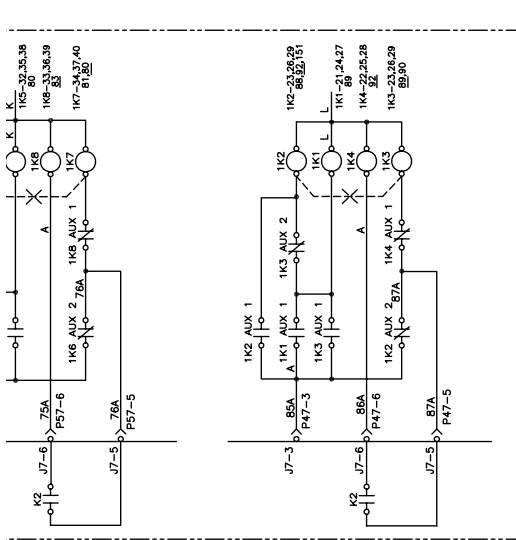

REVISED	20	DATE	BY NUMBER
2-4-84			
DESCRIPTION	THE TRANE COMPANY A DIVISION OF AMERICAN STANDARD INC.		
SH	HELICAL ROTOR HERMETIC LIQUID CHILLER SERIES "R" WATER COOLED CHILLER SCHEMATIC WIRING RTWA 70-125 TON		
10-7-92	SIMILAR TO		PAGE 2

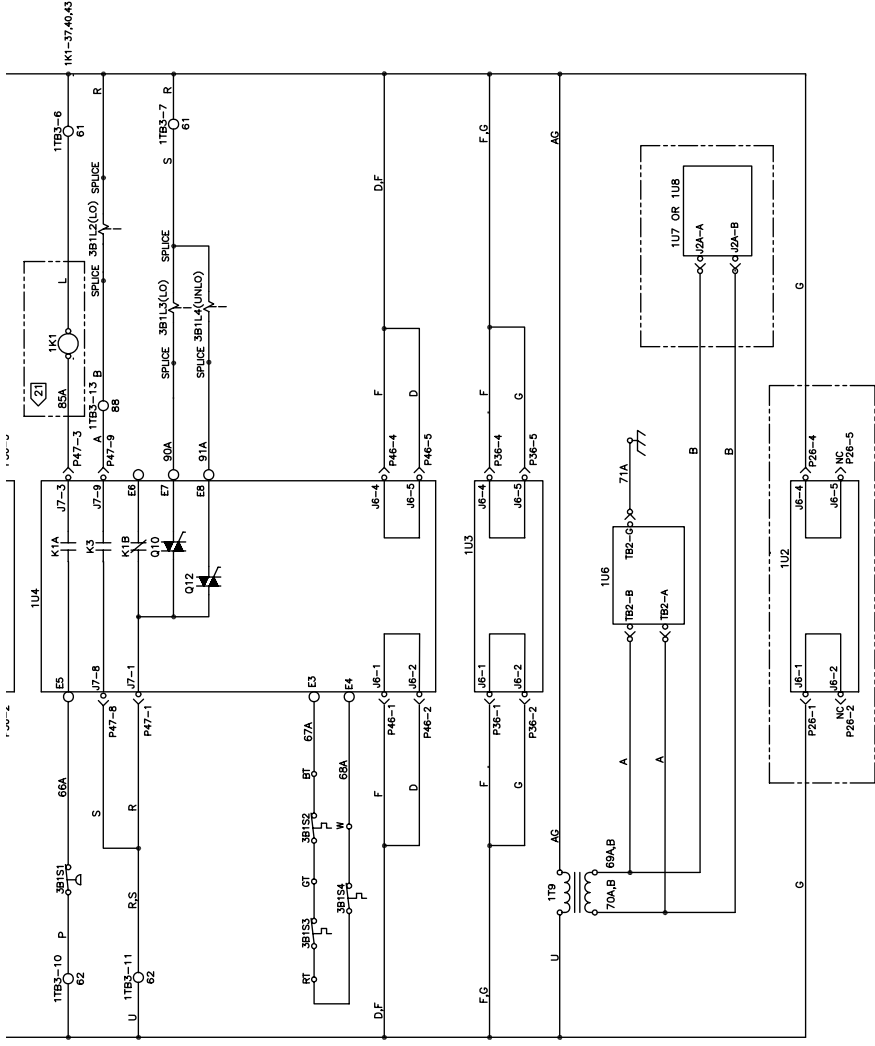
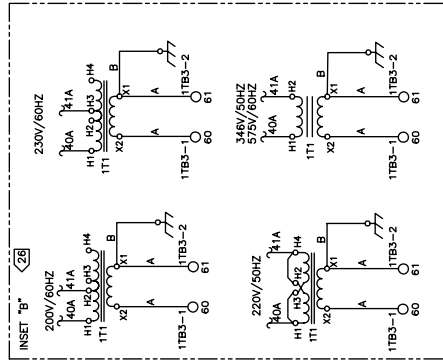

IN ACTUAL PANEL LAYOUT ALL 115 VOLT CONNECTIONS TO MODULES APPEAR ON THE RIGHT-HAND-SIDE OF THE MODULE.
 380/415V/50HZ UNITS ARE FACTORY CONNECTED AS 415V UNITS. 380V UNITS REQUIRE THAT THE APPROPRIATE LEADS BE RE-CONNECTED TO OR FROM TRANSFORMER (1T1) AS SHOWN IN INSET B.
 THE EXTERNAL AUTO/STOP INPUT IS A CUSTOMER PROVIDED INPUT. THE EXTERNAL AUTO/STOP INPUT SHALL AS A TIME CLOCK OPENING THIS WILL EFFECT UNIT SHUTDOWN. NOTE THAT IF TRANE LCM EVAPORATOR PUMP CONTROL IS USED CHILLED WATER PUMP CONTROL SHALL BE CONNECTED TO THE LCM EXTERNAL AUTO/STOP INPUT.

- 90
- 91
- 92
- 93
- 94
- 95
- 96
- 97
- 98
- 99
- 100
- 101
- 102
- 103
- 104
- 105
- 106
- 107
- 108
- 109
- 110
- 111
- 112
- 113
- 114
- 115
- 116
- 117
- 118
- 119
- 120

- ⁽²¹⁾ X-L STARTER SHOWN SEE INSET "A" FOR WYE-DELTA CLOSED TRANSITION STARTER WIRING.
⁽²²⁾ CONTROL POWER TRANSFORMER (1T1) SHOWN FOR 460V 60HZ OR 415V 50HZ. FOR OTHER VOLTAGES SEE INSET "B".
⁽²³⁾ RELAY COILS NOT SHOWN, CONTACTS ARE CONTROLLED BY THE LOGIC OF THE MICRO MODULE (1U1). THE LOGIC OF THE MICRO MODULE (1U1) K1E-K2, K3 RELAY OUTPUTS CAN BE PROGRAMMED TO PERFORM ALTERNATE FUNCTIONS. SEE INSTALLATION, OPERATION, AND MAINTENANCE MANUAL FOR DETAILS.

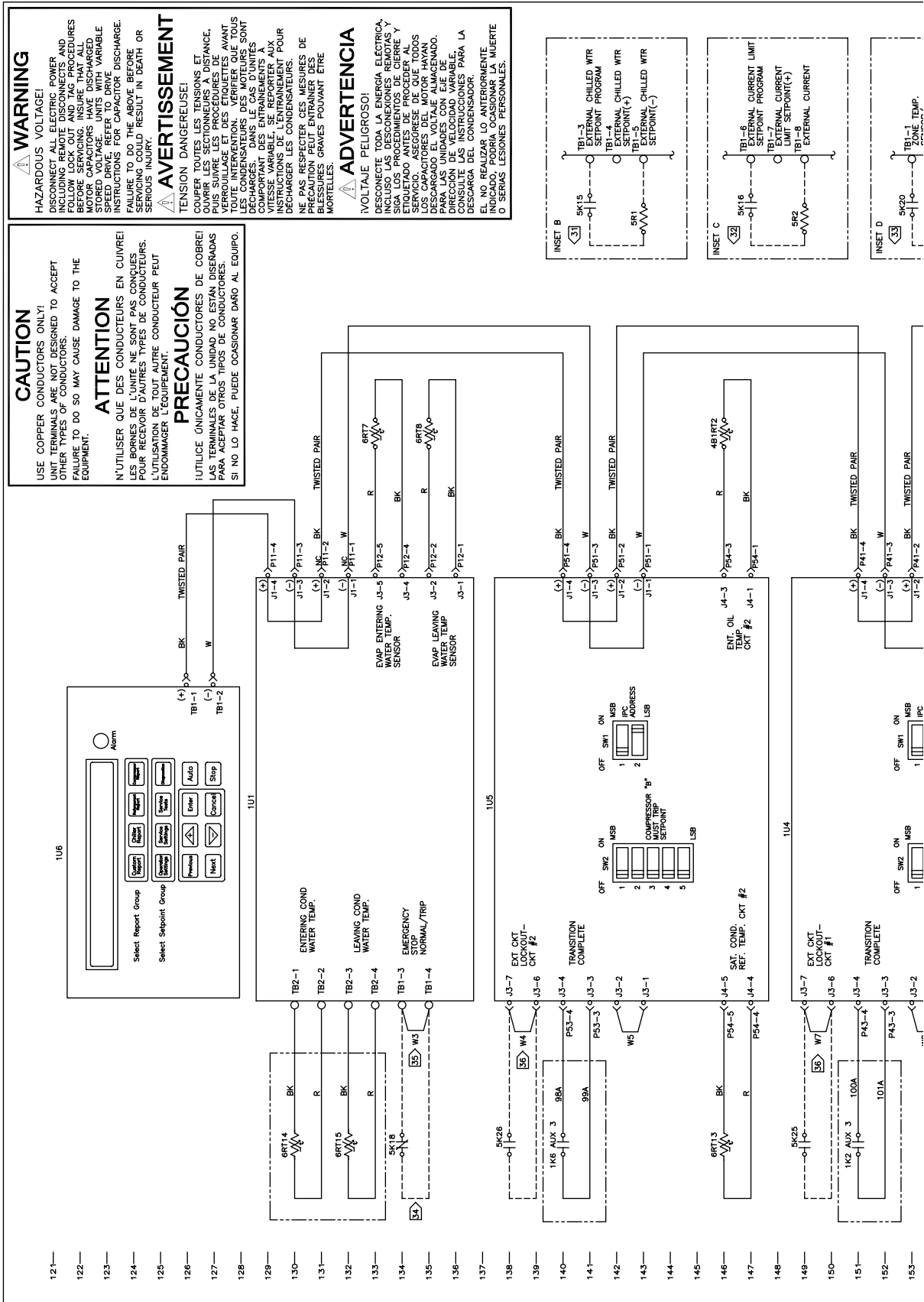

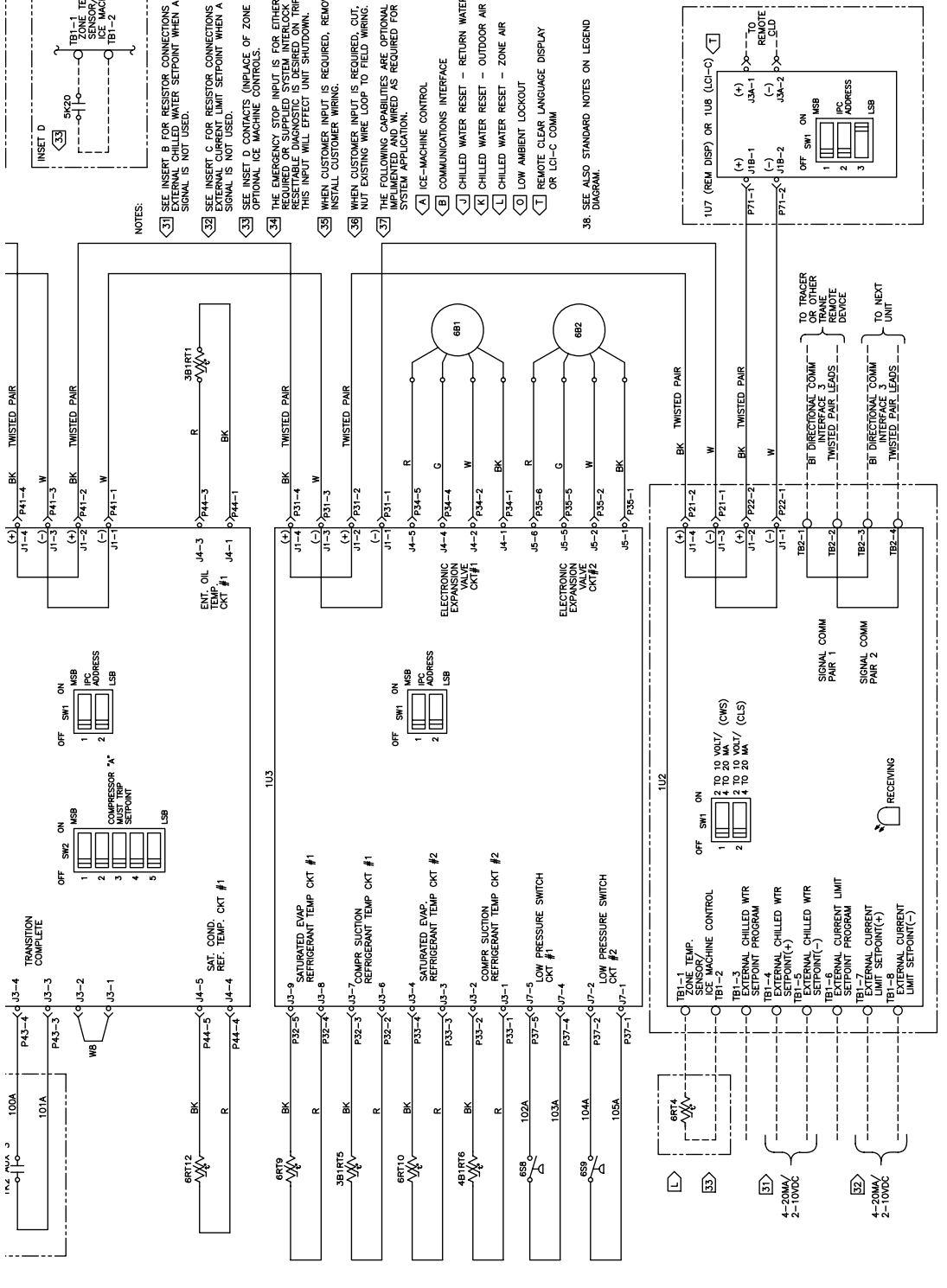

- NOTES:
- 31 SEE INSERT B FOR RESISTOR CONNECTIONS TO PROGRAM AN EXTERNAL CHILLED WATER SETPOINT WHEN A 4-20mA/2-10VDC SIGNAL IS NOT USED.
 - 32 SEE INSERT C FOR RESISTOR CONNECTIONS TO PROGRAM AN EXTERNAL CURRENT LIMIT SETPOINT WHEN A 4-20mA/2-10VDC SIGNAL IS NOT USED.
 - 33 SEE INSERT D CONTACTS (IN PLACE OF ZONE TEMP SENSOR) FOR OPTIONAL ICE MACHINE CONTROLS.
 - 34 THE EMERGENCY STOP INPUT IS FOR EITHER A CUSTOMER REQUIRED OR SUPPLIED SYSTEM INTERLOCK WHERE A MANUAL STOP INPUT WILL EFFECT UNIT SHUTDOWN.
 - 35 WHEN CUSTOMER INPUT IS REQUIRED, REMOVE JUMPER AND INSTALL CUSTOMER WIRING.
 - 36 WHEN CUSTOMER INPUT IS REQUIRED, CUT, STRIP, AND WIRE NOT EXISING WIRE LOOP TO FIELD WIRING.
 - 37 THE FOLLOWING CAPABILITIES ARE OPTIONAL - THEY ARE INSTALLED AS REQUIRED FOR A SPECIFIC SYSTEM APPLICATION.
 - A ICE-MACHINE CONTROL
 - B COMMUNICATIONS INTERFACE
 - J CHILLED WATER RESET - RETURN WATER
 - K CHILLED WATER RESET - OUTDOOR AIR
 - L CHILLED WATER RESET - ZONE AIR
 - O LOW AMBIENT LOCKOUT
 - T REMOTE CLEAR LANGUAGE DISPLAY OR LCI-C COMM
 - 38 SEE ALSO STANDARD NOTES ON LEGEND DIAGRAM.

181—

182—

183—

184—

185—

186—

187—

188—

189—

190—

191—

192—

193—

194—

195—

196—

197—

198—

199—

200—

201—

202—

203—

204—

205—

206—

207—

208—

209—

210—

211—

⚠ WARNING
HAZARDOUS VOLTAGE!
DISCONNECT ALL ELECTRIC POWER FROM THE UNIT BEFORE YOU FOLLOW LOCK-OUT AND TAG PROCEDURES BEFORE SERVICING. INSURE THAT ALL MOTOR CAPACITORS HAVE VARIABLE SPEED DRIVE (VSD) TO DRIVE INSTRUCTIONS FOR CAPACITOR DISCHARGE. FAILURE TO DO THE ABOVE BEFORE SERVICING COULD RESULT IN DEATH OR SERIOUS INJURY.

⚠ AVERTISSEMENT
TENSION DANGEREUSE!
COUPER TOUS LES TENSIONS ET DÉCONNECTER LA SOURCE D'ÉNERGIE ÉLECTRIQUE AVANT DE SUIVRE LES PROCÉDURES DE VERROUILLAGE ET DES ÉTIQUETTES AVANT TOUTE INTERVENTION. VÉRIFIER QUE TOUS LES CONDENSATEURS DES MOTEURS À VITESSE VARIABLE (VSD) SONT DÉCHARGÉS. DANS LE CAS D'UNITÉS COMPORTANT DES ENTRAÎNEMENTS À VITESSE VARIABLE, SE REPORTER AUX INSTRUCTIONS POUR LA DÉCHARGE DES CONDENSATEURS. NE PAS RESPECTER CES MESURES DE PRÉCAUTION PEUT ENTRAÎNER DES BLESSURES GRAVES POUVANT ÊTRE MORTELLES.

⚠ ADVERTENCIA
¡VOLTAJE PELIGROSO!
DESCONECTE TODA LA ENERGÍA ELÉCTRICA, INCLUIDO LAS DESCONEXIONES REMOTAS, Y SIGA LOS PROCEDIMIENTOS DE CIERRE Y ETIQUETADO ANTES DE PROCEDER A LOS SERVICIOS. VERIFIQUE QUE TODOS LOS CAPACITORES DE LOS MOTORES HAYAN DESCARGADO EL VOLTAJE ALMACENADO. PARA LAS UNIDADES CON CIE DE VITESSE VARIABLE, VÉASE REPORTE A LAS INSTRUCCIONES PARA LA DESCARGA DEL CONDENSADOR. EL NO REALIZAR LO ANTERIORMENTE INDICADO, PODRÍA OCASIONAR LA MUERTE O SERIAS LESIONES PERSONALES.

AREA	LOCATION	DEVICE PREFIX LOCATION CODE
1	CONTROL PANEL	
2	REMOTE EVAPORATOR	
3	FIRST CIRCUIT COMPR. & FANS	
4	SECOND CIRCUIT COMPR. & FANS	
5	CUSTOMER PROVIDED	
6	UNIT MOUNTED	

CAUTION
USE COPPER CONDUCTORS ONLY!
OTHER TYPES OF WIRE NOT DESIGNED TO ACCEPT FAILURE TO DO SO MAY CAUSE DAMAGE TO THE EQUIPMENT.

ATTENTION
N'UTILISER QUE DES CONDUCTEURS EN CUIVRE!
LES BORNES DE L'UNITÉ NE SONT PAS CONÇUES POUR RECEVOIR D'AUTRES TYPES DE CONDUCTEURS. L'UTILISATION DE TOUT AUTRE CONDUCTEUR PEUT ENDOMMAGER L'EQUIPEMENT.

PRECAUCIÓN
¡UTILICE ÚNICAMENTE CONDUCTORES DE COBRE!
TERMINALES DE LA UNIDAD NO ESTÁN DISEÑADOS PARA RECEBIR OTROS TIPOS DE CONDUCTORES. SI NO LO HACE, PUEDE OCASIONAR DAÑO AL EQUIPO.

LINE NUMBER	LEGEND	DESCRIPTION
4		CHILLED WATER PUMP MOTOR
13		CONDENSER WTR PUMP - OR- CONDENSER PROVIDED BY OTHERS
22		COOLING TOWER MOTOR
7		CHILLED WATER PUMP TIME DELAY (1 MINUTE) (N.O.INST. C.I.S.,I.O.)
9		CHILLER WATER PUMP STARTER
165		ALARM RELAY
177		THAW RELAY
143		THAWING RELAY
149		MAX CAPACITY OUTPUT RELAY
141		EXT. CHILLED WTR SETPOINT RELAY
147		EXT. CURRENT LIMIT SETPOINT RELAY
134		EMERGENCY STOP RELAY
153		ICE MACHINE CONTROL RELAY
149		EXT. CKT LOCKOUT RELAY - CK#1
138		EXT. CKT LOCKOUT RELAY - CK#2
177		CONDENSER WTR PUMP STARTER
26		COOLING TOWER STARTER
143		EXT. CHILLED WATER SETPOINT RESISTOR
149		EXT. CHILLED WATER SETPOINT RESISTOR
149		OUTDOOR AIR TEMPERATURE SENSOR
8		CHILLED WATER SYSTEM DEMAND SWITCH
165		ELECTRONIC EXPANSION VALVE CKT #1
169		ELECTRONIC EXPANSION VALVE CKT #2
173		ZONE TEMP SENSOR
135		EVAP ENT. WTR TEMP. SENSOR
160		EVAP LVG. WTR TEMP. SENSOR
166		SAT. EVAP RFGT TEMP. SENSOR CKT #1
164		SAT. EVAP RFGT TEMP. SENSOR CKT #2
157		SAT. COND. RFGT TEMP. SENSOR CKT #1
166		SAT. COND. RFGT TEMP. SENSOR CKT #2
132		COND. LVG WTR TEMP. SENSOR
130		COND. LVG WTR TEMP. SENSOR
168		LOW PRESSURE SWITCH CKT#1
170		LOW PRESSURE SWITCH CKT#2

LINE NUMBER	LEGEND	DESCRIPTION
65		CONTROL CKT FUSE
57,58		CONTROL POWER TRANS. FUSES
90,91,79,81		START CONTACTORS
89,90		RUN CONTACTORS
91,82		TRANSITION CONTACTORS
92,83		SHORTING CONTACTORS
22,25,28,57-59		TRANSITION RESISTORS CKT #1
33		TRANSITION RESISTORS CKT #2
62, 85		MOAR-FUSED DISCONNECT SWITCH
104		CHILLER WTR PUMP STARTER
21,24,27,37,40,43		CHILLER WTR PUMP TIME DELAY
32,35,38,48,51,54		CHILLER WTR PUMP TIME DELAY
105		CLD TRANSFORMER
33		LINE VOLTAGE TERMINAL BLOCK
1183		TERMINAL STRIP 115V
1188-9		TERMINAL STRIP 24V
101		CHILLER MODULE
111,172		OPTIONS MODULE
66,57,128		EXP. VALVE MODULE (EVV)
18,102,157		START RELAY CPRSR A
18,34,90,148		CPRSR MODULE - CPRSR B
91		CRANKCASE HEATER RELAY CPRSR A
93		CRANKCASE HEATER RELAY CPRSR B
01		TRANSITION RELAY CPRSR A
45,78,137		CPRSR MODULE - CPRSR B
79		START RELAY CPRSR B
81		CRANKCASE HEATER RELAY CPRSRB
82		TRANSITION RELAY CPRSR B
94		SLIDE VALVE LOAD CKT #1 (TRAC)
95		SLIDE VALVE UNLOAD CKT #1 (TRAC)
82		SLIDE VALVE LOAD CKT #2 (TRAC)
83		SLIDE VALVE UNLOAD CKT #2 (TRAC)
107,121		CLEAR LANGUAGE DISPLAY MODULE
106,174		REMOTE DISPLAY BUFFER MODULE
108,174		LCL-C COMM MODULE
24,40		COMPRESSOR A CKT #1
84		STEP LOAD SOLENOID CKT #1 (FIRST STEP)
84		SLIDE VALVE UNLOAD SOLENOID CKT #1
95		SLIDE VALVE UNLOAD SOLENOID CKT #1
91		HIGH PRESSURE SWITCH CKT #1
96,99		WINDING THERMOSTATS CKT #1
157		ENT. OIL TEMP. SENSOR CKT #1
182		CPRSR SUC RFGT TEMP SENSOR CKT #1
35,51		COMPRESSOR A CKT #2
82		STEP LOAD SOLENOID CKT #2 (FIRST STEP)
83		SLIDE VALVE UNLOAD SOLENOID CKT #2
90		SLIDE VALVE UNLOAD SOLENOID CKT #2
82		HIGH PRESSURE SWITCH CKT #2
96,97		ENT. OIL TEMP. SENSOR CKT #2
146		CPRSR SUC RFGT TEMP SENSOR CKT #2
166		CPRSR SUC RFGT TEMP SENSOR CKT #2

- NOTES:
- UNLESS OTHERWISE NOTED, ALL SWITCHES ARE SHOWN AT 25° C (77° F). AT ATMOSPHERIC PRESSURE AT 100% RELATIVE HUMIDITY, WITH AIR FLOW AS SHOWN FOR EACH CIRCUIT. A NORMAL SHUTDOWN HAS OCCURRED.
 - DASHED LINES INDICATE RECOMMENDED FIELD WIRING BY OTHERS. DASHED LINE ENCLOSURES AND/OR DASHED DEVICE OUTLINES INDICATE FIELD WIRING BY OTHERS. PHANTOM LINE ENCLOSURES INDICATE ALTERNATE CIRCUITRY OR AVAILABLE SALES OPTIONS. SOLID LINES INDICATE WIRING BY TRANE CO.
 - NUMBERS ALONG THE RIGHT SIDE OF THE WIRING DIAGRAM INDICATE THE CONTACTS BY LINE NUMBER. AN UNDERLINED NUMBER INDICATES A NORMALLY CLOSED CONTACT. A NUMBER WITH AN UNDERLINED LINE NUMBER POINTING UPWARD INDICATES A TIMED CONTACT WHICH BEGINS TIMING WHEN ENERGIZED.

UNIT SEQUENCE OF OPERATION

UNIT SEQUENCE OF OPERATION

210—
211—
212—
213—
214—
215—
216—
217—
218—
219—
220—
221—
222—
223—
224—
225—
226—
227—
228—
229—
230—
231—
232—
233—
234—
235—
236—
237—
238—
239—
240—

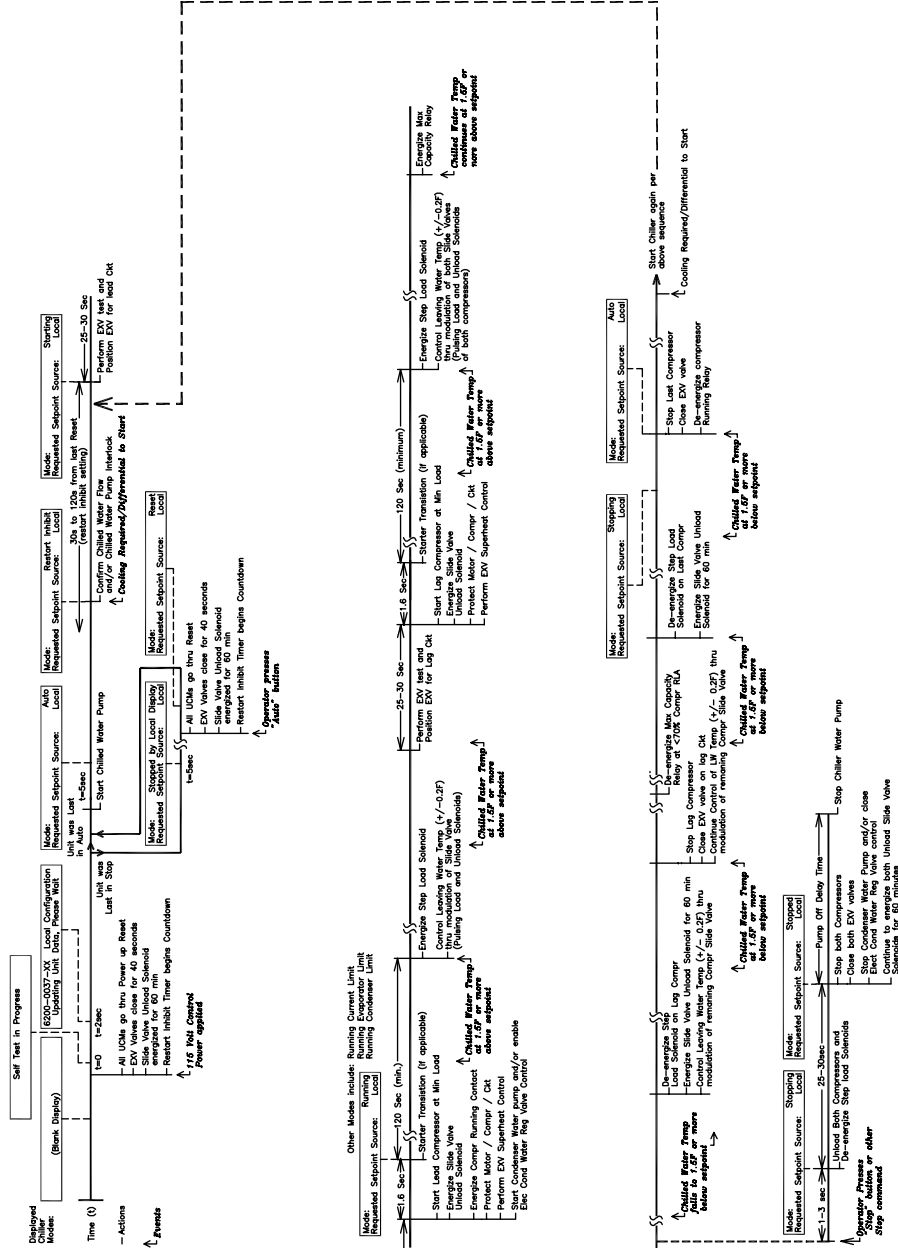

REPLACES	20 CAD	FILE NUMBER	2307-3335	PROJECT NUMBER	H
REVISED DATE	3-23-94	THE TRANE COMPANY a division of AMERICAN STANDARD INC.	HELICAL ROTOR HERMETIC LIQUID CHILLER SERIES "R" WATER COOLED CHILLER SCHEMATIC WIRING RTMA 70-125 TON		
SH					
DATE	02-4-93	DRAWN TO			PAGE 4

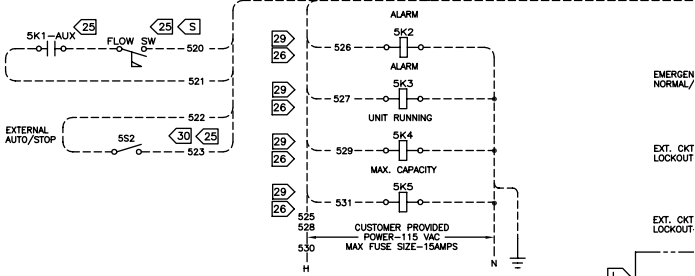
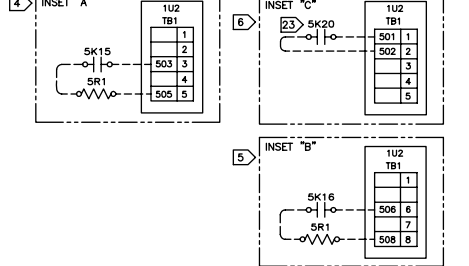
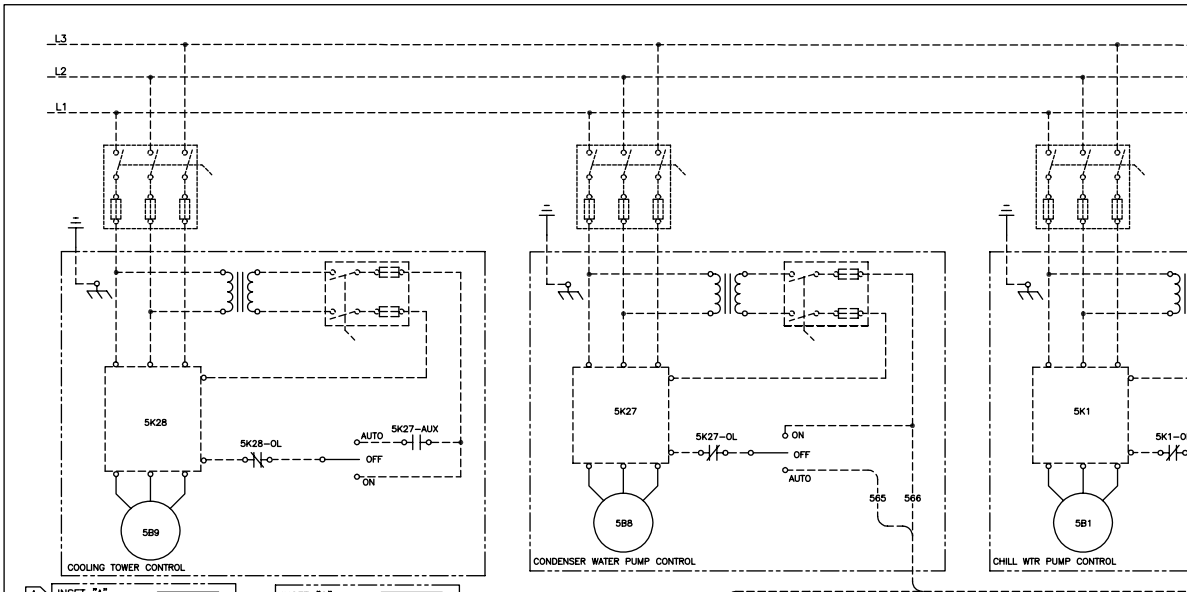

CUSTOMER WIRE SELECTION TABLE				HIGH TEMP (RTUA)					
POWER WIRE SELECTION TO DISCONNECT SWITCH(1S1)				DISCONNECT SWITCH SIZE					
UNIT SIZE	UNIT VOLTAGE	DISCONNECT SWITCH SIZE	CONNECTOR WIRE RANGE	UNIT SIZE	UNIT VOLTAGE	DISCONNECT SWITCH SIZE	CONNECTOR WIRE RANGE		
70	200/60	400	(1)3/0-500 MCM (1)3/0-250 MCM	70	200,230/60	400	(1)3/0-500 MCM (1)3/0-250 MCM		
	220/50	225	(1)2/0-300 MCM		220/50	225	(1)2/0-300 MCM		
	346,400/50 380,460/60 575/60	150	(1)#4-4/0		346,400/50 380,460/575/60	150	(1)#4-4/0		
80	200,230/60	400	(1)3/0-500 MCM (1)3/0-250 MCM	80	200,230/60	400	(1)3/0-500 MCM (1)3/0-250 MCM		
	220/50	225	(1)2/0-300 MCM		346/50	225	(1)2/0-300 MCM		
	346,400/50 380,460/575/60	150	(1)#4-4/0		400/50 460,575/60	150	(1)#4-4/0		
90	200,230/60	400	(1)3/0-500 MCM (1)3/0-250 MCM	90	200/60	400	(2)4/0-350 MCM		
	220/50	225	(1)2/0-300 MCM		230/60	400	(1)3/0-500 MCM (1)3/0-250 MCM		
	346/50 380/60	225	(1)2/0-300 MCM		220/50	400	(1)3/0-500 MCM (1)3/0-250 MCM		
100	400/50 460,575/60	150	(1)#4-4/0	100	200/60	400	(2)4/0-350 MCM		
	200,230/60	400	(1)3/0-500 MCM (1)3/0-250 MCM		220/50	225	(1)2/0-300 MCM		
	346,400/50 380,460/60	225	(1)2/0-300 MCM		220,346/50 230,380/60	400	(1)3/0-500 MCM (1)3/0-250 MCM		
110	200/60	600	(2)4/0-350 MCM	110	200,230/60	600	(2)4/0-350 MCM		
	220/50	400	(1)3/0-500 MCM (1)3/0-250 MCM		220,346/50 230/60	400	(1)3/0-500 MCM (1)3/0-250 MCM		
	346,400/50 380,460/60	225	(1)2/0-300 MCM		400/50 460,575/60	225	(1)2/0-300 MCM		
120	200/60	600	(2)4/0-350 MCM	120	200/60	600	(2)350-500 MCM		
	220/50	400	(1)3/0-500 MCM (1)3/0-250 MCM		220/50	600	(2)4/0-350 MCM		
	230/60	400	(2)4/0-350 MCM		346,400/50 380,460/60	400	(1)3/0-500 MCM (1)3/0-250 MCM		
POWER WIRE SELECTION TO MAIN TERMINAL BLOCK (1T1)				DISCONNECT SWITCH SIZE					
UNIT SIZE	UNIT VOLTAGE	TERMINAL BLOCK SIZE	CONNECTOR WIRE RANGE	UNIT SIZE	UNIT VOLTAGE	TERMINAL BLOCK SIZE	CONNECTOR WIRE RANGE		
70 - 125	200,230	780	#2 TO 500 MCM	70 - 125	460,575	335	#6 TO 350 MCM		
CONTROL WIRE SELECTION FOR 30 VOLT OR LESS CIRCUITS - SEE NOTE 24									
WIRE SIZE									
MAXIMUM LENGTH FOR SENSOR LEADS									
14 AWG 5000 FT									
18 AWG 2000 FT									
18 AWG 1000 FT									
FUSE REPLACEMENT SECTION									
FUSE DESCRIPTION	UNIT SIZE	UNIT VOLTAGE	FUSE TYPE	FUSE SIZE	FUSE DESCRIPTION	UNIT SIZE	UNIT VOLTAGE	FUSE TYPE	FUSE SIZE
CONTROL CIRCUIT FUSE (1F15)	ALL	ALL	CLASS CC	10 AMP	POWER CONTROL TRANSFORMER FUSE (1F15-1F17)	ALL	200/230V	CLASS CC	5 AMP
OPM & MCSP FUSE (1U1F1, 1U4F1 & 1U5F1)	ALL	ALL	BUSS GMC-1/4 LITTLE FUSE 239.250	0.25 AMP 5x20mm	EXV FUSE (1U3F1)	ALL	346,380/415 460,575V	CLASS CC (600V)	3 AMP
CSR FUSE (1U2F2)	ALL	ALL	BUSS GMC-2/10 LITTLE FUSE 239.200	0.20 AMP 5x20mm					

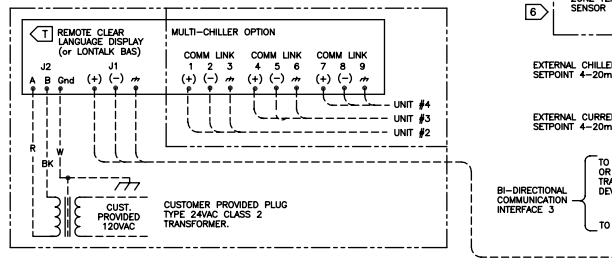

- NOTES:
- DASHED LINES INDICATE RECOMMENDED FIELD WIRING BY OTHERS, PHANTOM LINES INDICATE ALTERNATE CIRCUITRY OR AVAILABLE SALES OPTION. CHECK SALES ORDER TO DETERMINE IF WIRING IS REQUIRED FOR SPECIFIC OPTIONS.
 - ALL THREE PHASE MOTORS SUPPLIED WITH THE UNIT ARE PROTECTED UNDER PRIMARY SINGLE PHASE FAILURE CONDITIONS.
 - CAUTION - DO NOT ENERGIZE UNIT UNTIL CHECK OUT AND START-UP PROCEDURES HAVE BEEN COMPLETED.
 - SEE INSET "A" FOR RESISTOR CONNECTIONS TO PROGRAM AN EXTERNAL CHILLED WATER SETPOINT WHEN 4 - 20 mA OR 2 - 10 VDC SIGNAL IS NOT USED. SEE THE OPERATORS MANUAL FOR RESISTOR VALUES.
 - SEE INSET "B" FOR RESISTOR CONNECTIONS TO PROGRAM AN EXTERNAL CURRENT LIMIT SETPOINT WHEN 4 - 20 mA OR 2 - 10 VDC SIGNAL IS NOT USED. SEE THE OPERATORS MANUAL FOR RESISTOR VALUES.
 - SEE INSET "C" FOR CONTACTS (IN PLACE OF THE ZONE TEMP. SENSOR) FOR OPTIONAL ICE MACHINE CONTROL - OPTION "A".
 - THE FOLLOWING CAPABILITIES ARE OPTIONAL - THEY ARE IMPLEMENTED AND WIRED AS REQUIRED FOR A SPECIFIC SYSTEM APPLICATION.
 - A ICE-MACHINE CONTROL (CANNOT BE USED WITH OPT. L)
 - B COMMUNICATIONS INTERFACE
 - C WYE-DELTA CLOSED TRANSITION STARTER.
 - D DELETED
 - E DELETED
 - H UNIT DISCONNECT, NON-FUSED
 - J CHILLED WATER RESET - RETURN WATER
 - K CHILLED WATER RESET - OUTDOOR AIR
 - L CHILLED WATER RESET - ZONE AIR (CANNOT BE USED WITH OPT. A)
 - O LOW AMBIENT LOCKOUT
 - S CHILLED WATER FLOW SWITCH (NOT REQUIRED FOR CHILLER PROTECTION)
 - T REMOTE CLEAR LANGUAGE DISPLAY OF LCI-C BAS (BUFFER FOR DISPLAY LOCATED IN UNIT CONTROL PANEL)
- WIRING AND CONTACT REQUIREMENTS:
- ALL FIELD WIRING MUST BE IN ACCORDANCE CODE (NEC), STATE AND LOCAL REQUIREMENTS OTHER COUNTRIES APPLICABLE NATIONAL AN APPLIED.
 - DELETED
 - CUSTOMER SUPPLIED CONTACTS MUST BE C 45mA RESISTIVE LOAD, SILVER OR GOLD PL
 - 30 VOLT OR LESS CIRCUIT. DO NOT RUN IN CIRCUITS. USE #14-18 AWG, SEE SELECTIO
 - MINIMUM PILOT DUTY CONTACT RATING AT 1
 - FIELD WIRED ELECTRICAL LOADING IS NOT T
- | TERMINALS | DEVICE | VOLTAGE |
|---------------|----------|---------|
| 1U1-TB4-1,2 | 1U1K1,NO | 115 |
| 1U1-TB4-3 | 1U1K1,NC | 115 |
| 1U1-TB4-5,4 | 1U1K2,NO | 115 |
| 1U1-TB4-6,7 | 1U1K3,NC | 115 |
| 1U1-TB4-8,9 | 1U1K2,NO | 115 |
| 1U1-TB4-10,11 | 1U1K3,NC | 115 |
- * STANDARD PILOT DUTY RATING (350% POWI
IF EXTERNAL CIRCUIT LOCKOUT IS USED ON
AND SPLICE 45A AND 45B TO THE INDIVIDU
FOR CIRCUIT #2 CUT JUMPER WA AND SPLU
CUT ENDS OF THE JUMPER.
- AS SHIPPED 380/415 VOLT UNIT TRANSFORMI
415 VOLT OPERATION. IF UNIT IS TO BE OP
RE-CONNECT AS SHOWN IN INSET "D". REPR
SETTING MENU OF CLEAR LANGUAGE DISPLAY
 - K1, K2, K3 RELAY CONTACTS CAN BE PROFG
SEE INSTALLATION, OPERATION, AND MAINTEN
IS SHOWN.
 - CHILLED WATER PUMP CONTROL FROM TRAN
IS REQUIRED TO OPERATE A MINIMUM OF OI
CHILLER OPERATION (UCM WILL PROVIDE TIM
DEMAND SWITCH (5S2) IS CONNECTED TO TI

REVISION DATE	20 CAD	FIG. NUMBER	DRAWING NUMBER	REV.
2-3-94	THE TRANE COMPANY A DIVISION OF AMERICAN STANDARD INC.		2307-3336	D
APM			HELICAL ROTOR HERMETIC LIQUID CHILLER SERIES "R" WATER COOLED CHILLER FIELD WIRING RTWA 70-125 TON	
6-30-93				

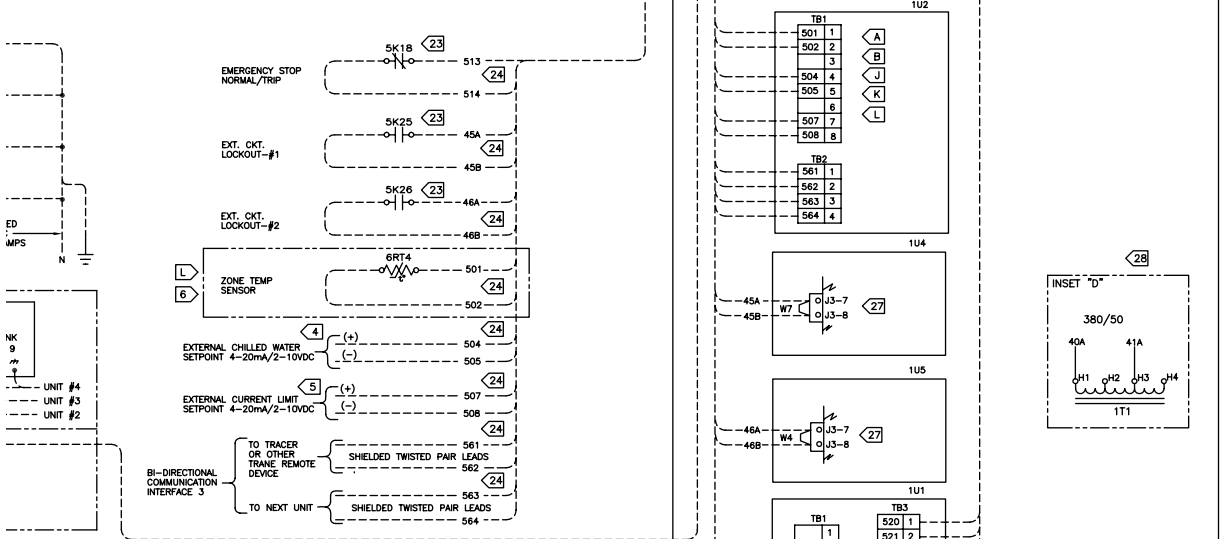
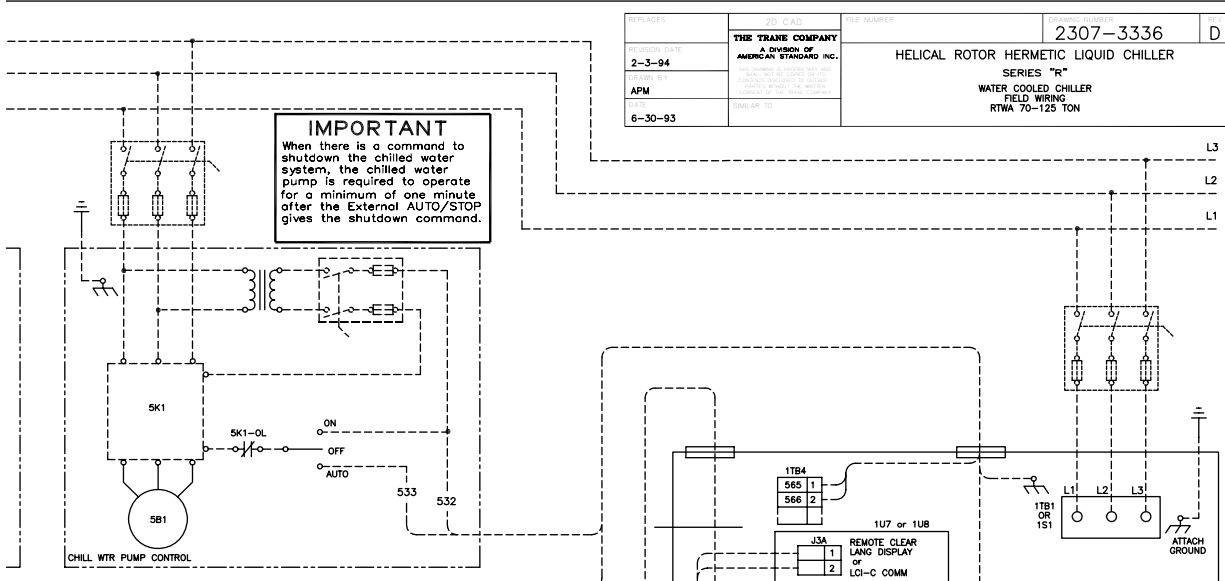

- WIRING AND CONTACT REQUIREMENTS:**
- ALL FIELD WIRING MUST BE IN ACCORDANCE WITH THE NATIONAL ELECTRICAL CODE (NEC), STATE AND LOCAL REQUIREMENTS, OUTSIDE THE UNITED STATES, OTHER COUNTRIES APPLICABLE NATIONAL AND/OR LOCAL REQUIREMENTS SHALL APPLY.
 - DELETED
 - CUSTOMER SUPPLIED CONTACTS MUST BE COMPATIBLE WITH DRY CIRCUIT 12VDC, 45mA RESISTIVE LOAD, SILVER OR GOLD PLATED CONTACTS ARE RECOMMENDED.
 - 30 VOLT OR LESS CIRCUIT, DO NOT RUN IN CONDUCT WITH HIGHER VOLTAGE CIRCUITS, USE #14-18 AWG, SEE SELECTION TABLE.
 - MINIMUM PILOT DUTY CONTACT RATING AT 115 VAC; 6.9VA INRUSH, 1.3VA SEALED.
 - FIELD WIRING ELECTRICAL LOADING IS NOT TO EXCEED THE FOLLOWING RATINGS:
- | TERMINALS | DEVICE | VOLTAGE | SEALED VA | INRUSH VA |
|---------------|----------|---------|-----------|-----------|
| 1U1-TB4-1,2 | 1U1K1,NO | 115 | 115 | 1150* |
| 1U1-TB4-3 | 1U1K1,NC | 115 | 115 | 1150* |
| 1U1-TB4-5,4 | 1U1K2,NO | 115 | 115 | 1150* |
| 1U1-TB4-6,7 | 1U1K3,NO | 115 | 115 | 1150* |
| 1U1-TB4-8,9 | 1U1K2,NO | 115 | 115 | 1150* |
| 1U1-TB4-10,11 | 1U1K3,NC | 115 | 115 | 1150* |
- * STANDARD PILOT DUTY RATING (35% POWER FACTOR).
- IF EXTERNAL CIRCUIT LOCKOUT IS USED ON CKT 1 CUT JUMPER W7 ON CIRCUIT #1 AND SPICE 45A AND 45B TO THE INDIVIDUAL OUT ENDS OF THE JUMPER. FOR CIRCUIT #2 CUT JUMPER W4 AND SPICE 46A AND 46B TO THE INDIVIDUAL OUT ENDS OF THE JUMPER.
 - AS SHIPPED 380/415 VOLT UNIT TRANSFORMER 1T1 IS WIRED FOR 415 VOLT OPERATION. IF UNIT IS TO BE OPERATED ON A 380 VOLT POWER SUPPLY, RE-CONNECT AS SHOWN IN INSET "D", REPROGRAM "UNIT LINE VOLTAGE" IN SERVICE SETTING MENU OF CLEAR LANGUAGE DISPLAY FROM 415 TO 380.
 - K1, K2, K3 RELAY OUTPUTS CAN BE PROGRAMED TO PERFORM ALTERNATE FUNCTIONS. SEE INSTALLATION, OPERATION, AND MAINTENANCE MANUAL FOR DETAILS, FUNCTION #1 IS SHOWN.
 - CHILLED WATER PUMP CONTROL FROM TRANE UNIT UCM MODULE, CHILLED WATER PUMP IS REQUIRED TO OPERATE A MINIMUM OF ONE MINUTE AFTER A COMMAND TO TERMINATE CHILLER OPERATION (UCM WILL PROVIDE TIME DELAY CONTACTS). CHILLED WATER SYSTEM DEMAND SWITCH (552) IS CONNECTED TO THE UCM EXTERNAL AUTO/STOP INPUT.

<p>WARNING</p> <p>HAZARDOUS VOLTAGE!</p> <p>DISCONNECT ALL ELECTRIC POWER INCLUDING REMOTE DISCONNECTS AND FOLLOW LOCK OUT AND TAG PROCEDURES BEFORE SERVICING. INSURE THAT ALL MOTOR CAPACITORS HAVE DISCHARGED STORED VOLTAGE. UNITS WITH VARIABLE SPEED DRIVE, REFER TO DRIVE INSTRUCTIONS FOR CAPACITOR DISCHARGE.</p> <p>FAILURE TO DO THE ABOVE BEFORE SERVICING COULD RESULT IN DEATH OR SERIOUS INJURY.</p>	<p>AVERTISSEMENT</p> <p>TENSION DANGEREUSE!</p> <p>COUPER TOUTES LES TENSIONS ET OUVRIR LES SECTIONNEURS A DISTANCE, PUIS SUIVRE LES PROCEDURES DE VERROUILLAGE ET DES ETIQUETTES AVANT TOUTE INTERVENTION. VERIFIER QUE TOUTS LES CONDENSATEURS DES MOTEURS SONT DECHARGES. DANS LE CAS D'UNITES COMPORTANT DES ENTRAINEMENTS A VITESSE VARIABLE, SE REPORTER AUX INSTRUCTIONS DE L'ENTRAINEMENT POUR DECHARGER LES CONDENSATEURS.</p> <p>NE PAS RESPECTER CES MESURES DE PRECAUTION PEUT ENTRAENER DES BLESSURES GRAVES POUVANT ETRE MORTELLES.</p>	<p>ADVERTENCIA</p> <p>¡VOLTAJE PELIGROSO!</p> <p>DESCONECTE TODA LA ENERGÍA ELÉCTRICA, INCLUSO LAS DESCONEXIONES REMOTAS Y SIGA LOS PROCEDIMIENTOS DE CIERRE Y ETIQUETADO ANTES DE PROCEDER AL SERVICIO. ASEGÚRESE DE QUE TODOS LOS CAPACITORES DEL MOTOR HAYAN DESCARGADO EL VOLTAJE ALMACENADO. PARA LAS UNIDADES CON EJE DE DIRECCIÓN DE VELOCIDAD VARIABLE, CONSULTE LAS INSTRUCCIONES PARA LA DESCARGA DEL CONDENSADOR.</p> <p>EL NO REALIZAR LO ANTERIORMENTE INDICADO, PODRÍA OCASIONAR LA MUERTE O SERIAS LESIONES PERSONALES.</p>
--	--	---

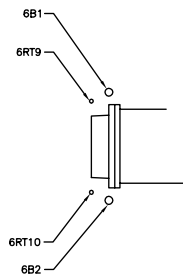

DETAIL A
RTWA 110 & 120 TON

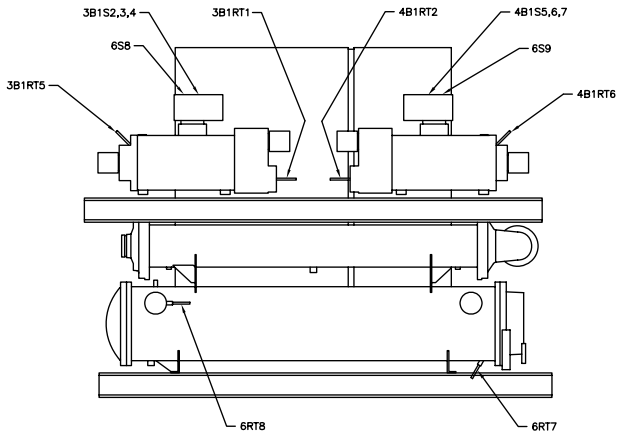
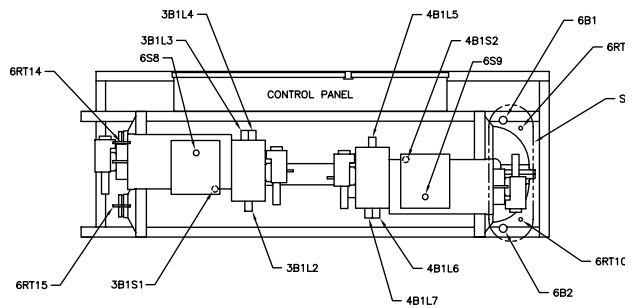

RTWA 70 - 100 TON

DETAIL OF CONTROL PANEL W/STAR-DELTA START

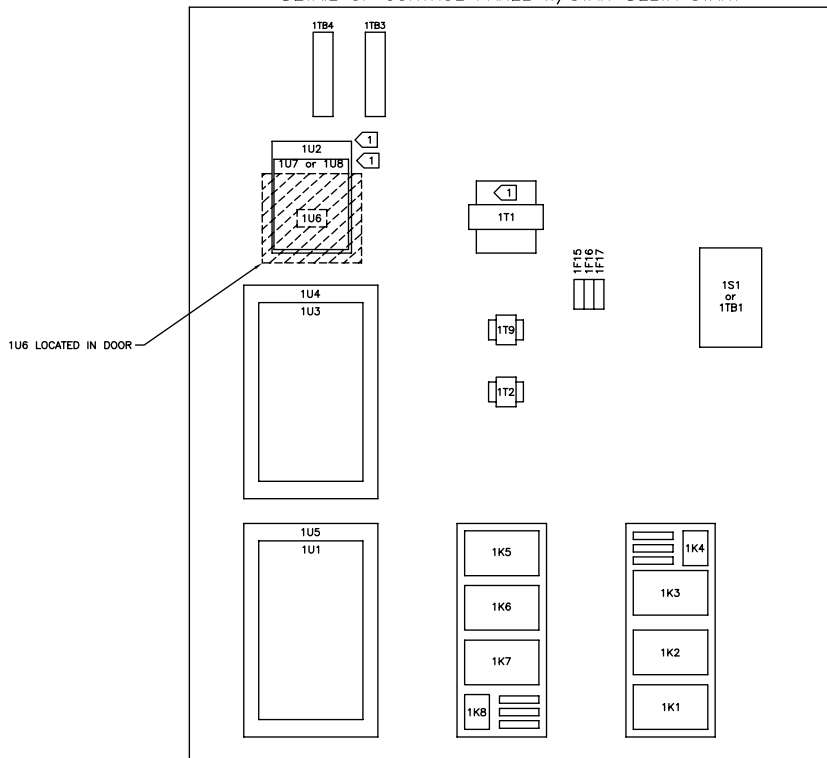

DETAIL

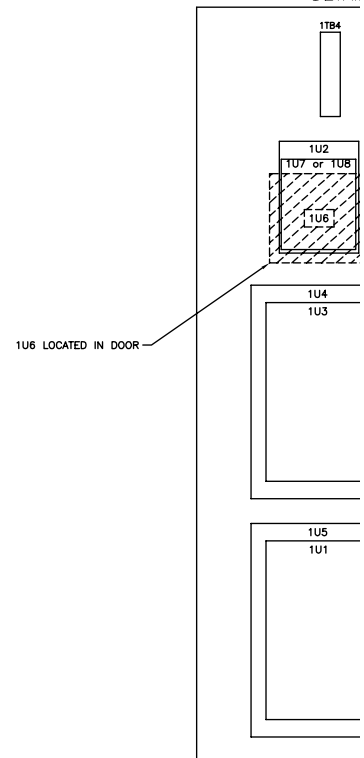

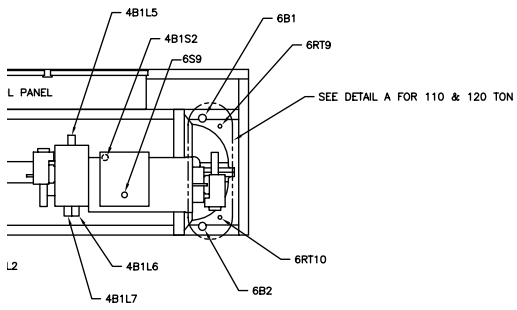

REPLACES	2307-5119	DRAWING NUMBER	2307-5119	REV.	G
DESIGN DATE	2-8-94	THE TRANE COMPANY A DIVISION OF AMERICAN STANDARD INC.	HELICAL ROTOR HERMETIC LIQUID CHILLER RTWA 70-120 TON COMPONENT LOCATION		
DRAWN BY	SH	DATE	5-26-93		

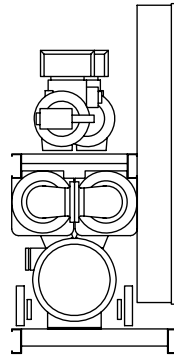
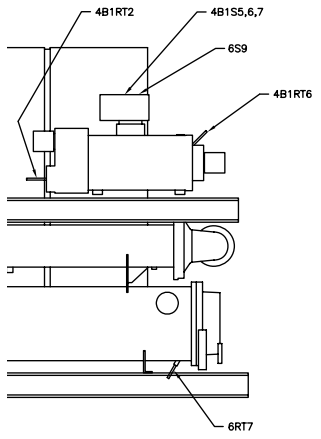

- 100 TON

DETAIL OF CONTROL PANEL W/X-LINE START

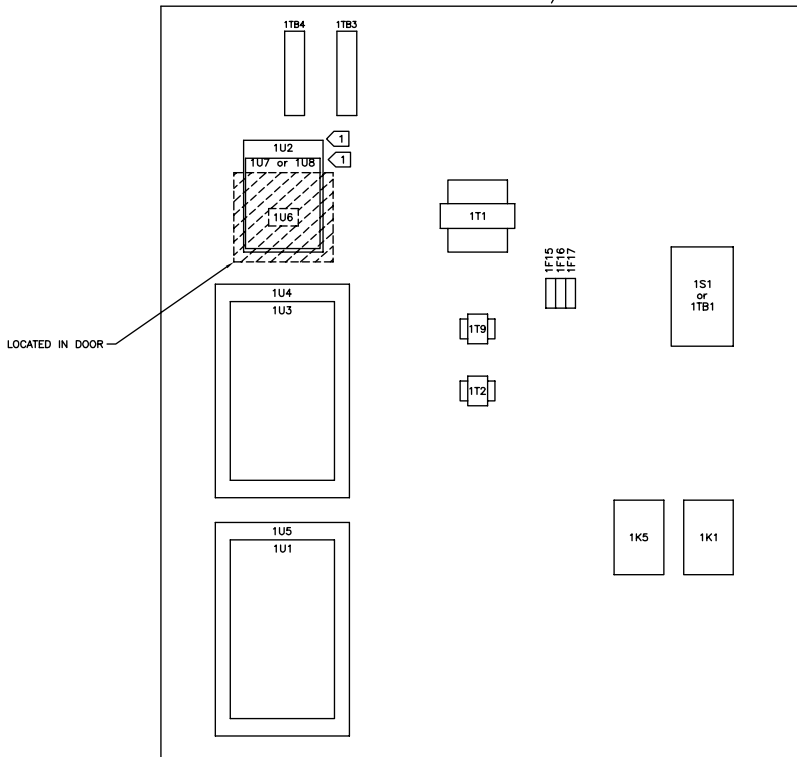

CAUTION

USE COPPER CONDUCTORS ONLY!
UNIT TERMINALS ARE NOT DESIGNED TO ACCEPT
OTHER TYPES OF CONDUCTORS.
FAILURE TO DO SO MAY CAUSE DAMAGE TO THE
EQUIPMENT.

ATTENTION

N'UTILISER QUE DES CONDUCTEURS EN CUIVRE!
LES BORNES DE L'UNITÉ NE SONT PAS CONÇUES
POUR RECEVOIR D'AUTRES TIPIES DE CONDUCTEURS.
L'UTILISATION DE TOUT AUTRE CONDUCTEUR PEUT
ENDOMMAGER L'ÉQUIPEMENT.

PRECAUCIÓN

UTILICE ÚNICAMENTE CONDUCTORES DE COBRE!
LAS TERMINALES DE LA UNIDAD NO ESTÁN DISEÑADAS
PARA ACEPTAR OTROS TIPOS DE CONDUCTORES.
SI NO LO HACÉ, PUEDE OCASIONAR DAÑO AL EQUIPO.

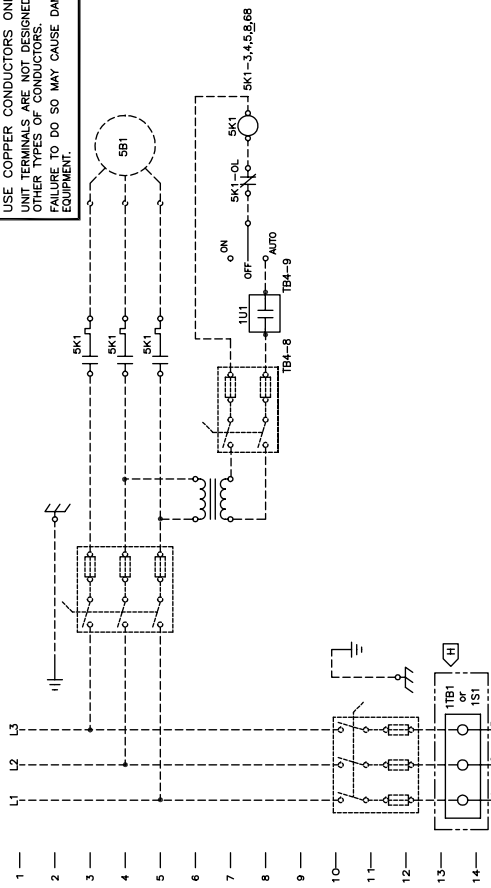

HAZARDOUS VOLTAGE!
DANGER TO LIFE!
INCLUDING REMOTE DISCONNECTS
AND FOLLOW LOCK OUT AND TAG
PROCEDURES BEFORE SERVICING.
CAPACITORS HAVE DISCHARGED
STORED VOLTAGE. UNITS WITH
VARIABLE SPEED DRIVE, REFER
CAPACITOR DISCHARGE FOR
FAILURE TO DO THE ABOVE
BEFORE SERVICING COULD RESULT
IN DEATH OR SERIOUS INJURY.

AVERTISSEMENT
TENSION DANGEREUSE!
DANGER TO LIFE!
OUVRIR LES SECTIONNEURS À DISTANCE,
ET SUIVRE LES PROCÉDURES DE
VERROUILLAGE ET DES ÉTIQUETTES AVANT
LES TRAVAUX DE RÉPARATION.
LES CONDENSATEURS DES MOTEURS SONT
DÉCHARGÉS DANS LE CAS D'UNITÉS
COMPORTANT DES ENTRAÎNEMENTS À
VITESSE VARIABLE. RÉFÉRER-SE AUX
INSTRUCTIONS DE DÉCHARGEMENT POUR
LES CONDENSATEURS.

ADVERTENCIA
¡VOLTAJE PELIGROSO!
¡DANGER A LA VIDA!
INCLUSO LAS DESCONECCIONES REMOTAS,
SIGA LOS PROCEDIMIENTOS DE CIERRE Y
ETIQUETADO ANTES DE PROCEDER AL
TRABAJO DE REPARACIÓN.
LOS CAPACITORES DEL MOTOR HAYAN
DESCARGADO EL VOLTAJE ALMACENADO.
PARA LAS UNIDADES CON EJE DE
ENTRAÍNAMIENTO A VITESSE VARIABLE,
CONSULTE LAS INSTRUCCIONES PARA LA
DESCARGA DEL CONDENSADOR.

EL NO REALIZAR LO ANTERIORMENTE
INDICADO, PODRÍA OCASIONAR LA MUERTE
O SERIAS LESIONES PERSONALES.

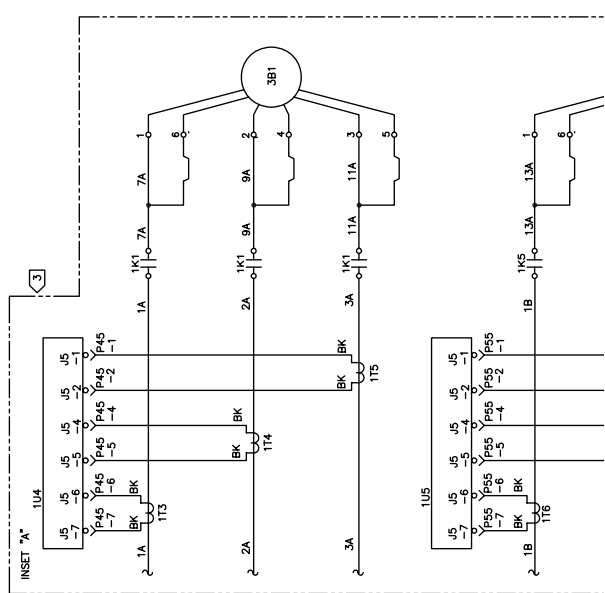
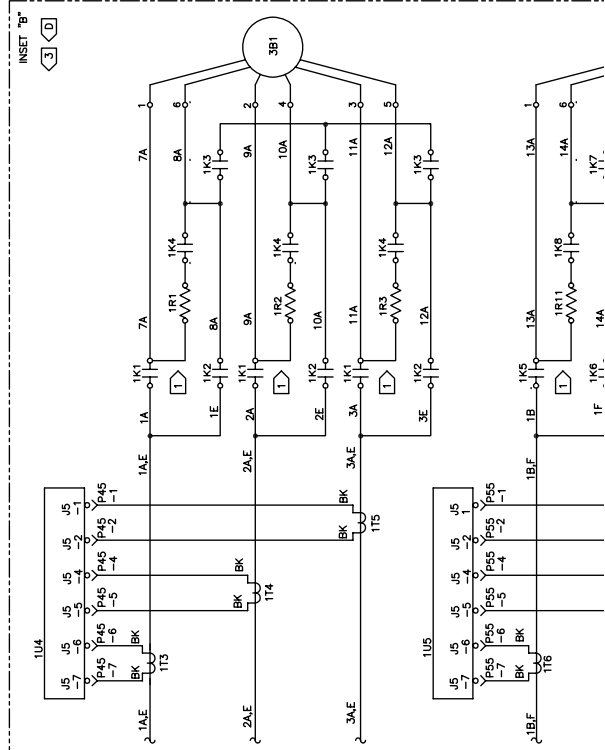

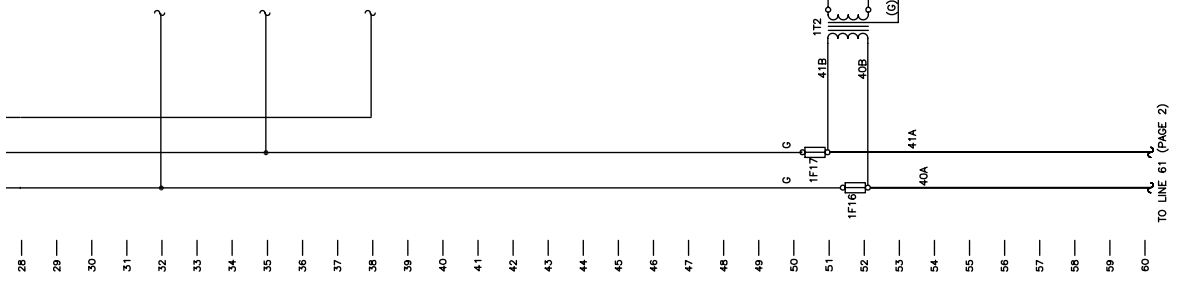
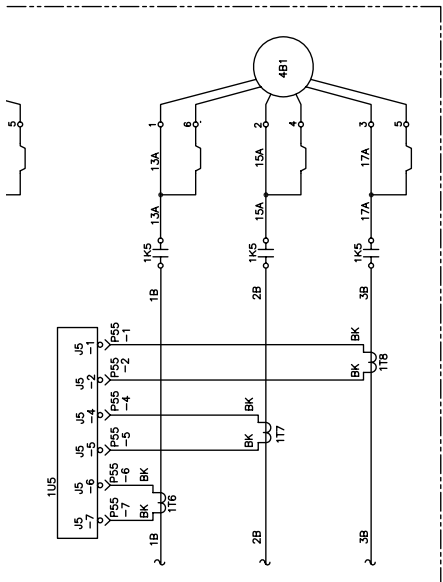
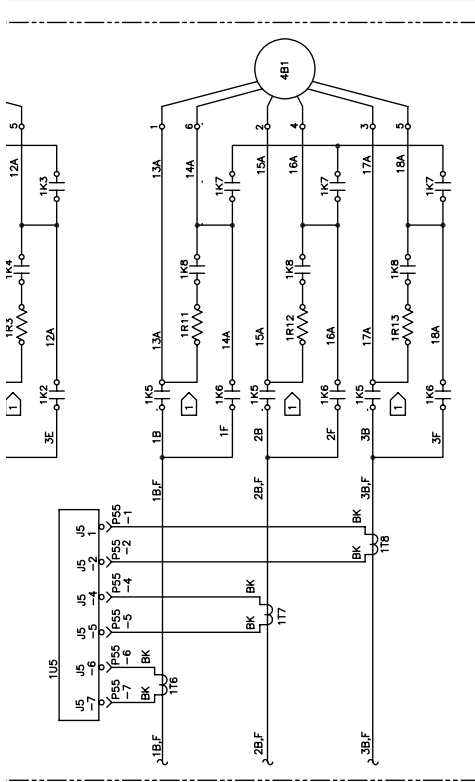

REPLACES	2D C AD	REV. NUMBER	2307-5143	B
REVISION DATE	THE TRANE COMPANY A DIVISION OF AMERICAN STANDARD INC.			
DESIGNED BY	HELICAL ROTOR HERMETIC LIQUID CHILLER SERIES "R" COMPRESSOR / CHILLER SCHEMATIC WIRING RTUA 70-125 TON			
DATE	5-2-94			
SYMBOLS TO	SEE ALSO STANDARD NOTES ON LEGEND DIAGRAM.			

- NOTES:
- THE FOLLOWING CAPABILITIES ARE OPTIONAL. THESE CAPABILITIES ARE NOT STANDARD. CONFIGURATIONS MAY VARY BY UNIT VOLTAGE AND STARTER MANUFACTURER. THEY ARE IMPLEMENTED AS REQUIRED FOR A SPECIFIC SYSTEM APPLICATION.
 - UNIT DISCONNECT. NON-FUSED
 - WYE-DELTA CLOSED TRANSITION STARTER
 - SEE INSET "B" FOR WYE-DELTA CLOSED TRANSITION STARTER WIRING
 - SEE ALSO STANDARD NOTES ON LEGEND DIAGRAM.

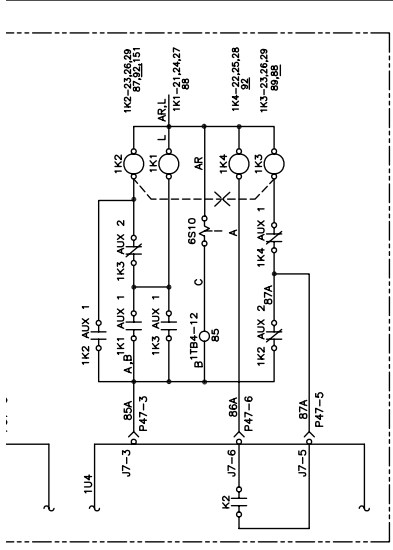

REVISED	2010-04-02	REV NUMBER	2307-5144	REV DATE	04/02/10
REVISED DATE	5-13-94	THE TRANE COMPANY A DIVISION OF AMERICAN STANDARD INC.	HELICAL ROTOR HERMETIC LIQUID CHILLER SERIES "R" COMPRESSOR / CHILLER SCHEMATIC WIRING RTUA 70-125 TON		C
REVISED BY	AM				PAGE 2
REVISED BY	5-2-94				

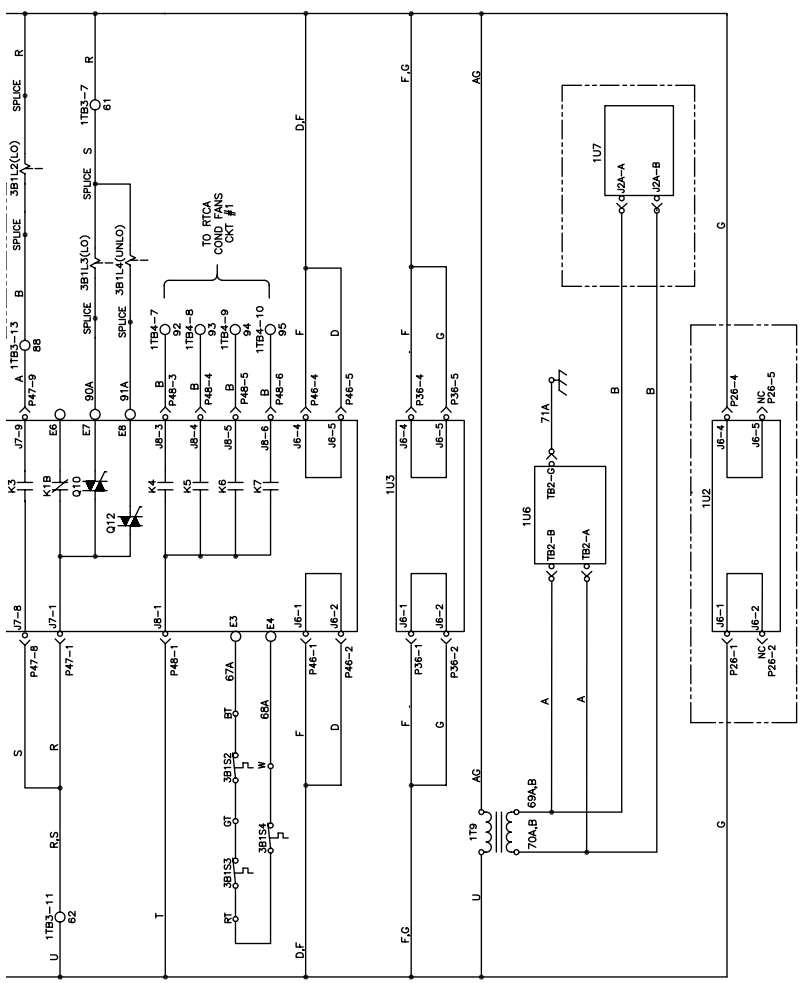
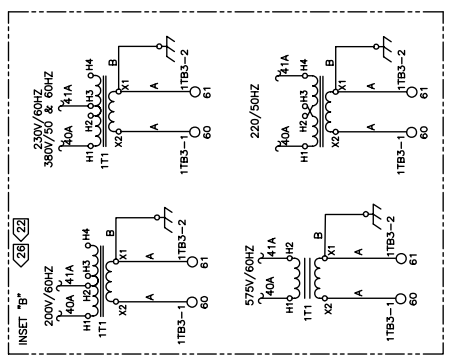

- NOTES:
- 21 K1 STARTER SHOWN. SEE INSET "A" FOR WYE-DELTA CLOSED TRANSITION STARTER WIRING.
 - 22 TRANSFORMER SHOWN IS WIRED FOR 415V/50HZ. 460V/60HZ SEE INSET "B" FOR OTHER VOLTAGES.
 - 23 RELAY COILS NOT SHOWN. CONTACTS ARE CONTROLLED BY THE LOGIC OF THE MICRO MODULE (U11). SEE SEQUENCE OF OPERATIONS.
 - 24 K1, K2, K3 RELAY OUTPUTS CAN BE PROGRAMMED ON, OFF, OR LOCKED. SEE SEQUENCE OF OPERATIONS, OPERATION, AND MAINTENANCE MANUAL FOR DETAILS.
 - 25 IN ACTUAL PANEL LAYOUT ALL 115 VOLT CONNECTIONS OF THE MODULE.
 - 26 380/415V 50/60HZ UNITS USE FACTORY CONNECTED AS SHOWN. 460V/60HZ UNITS MUST BE RE-CONNECTED TO TRANSFORMER (T1) AS SHOWN IN INSET B.
 - 27 THE EXTERNAL AUTO/STOP INPUT IS FOR A CUSTOMER PROVIDED EXTERNAL SYSTEM AUTO/STOP/START INPUT SUCH AS A TIME CLOCK. OPENING THIS INPUT ON THE MICRO MODULE WILL STOP THE CHILLER WATER EVAPORATOR PUMP CONTROL. USED CHILLED WATER SYSTEM DEMAND SWITCH (SS2) IS CONNECTED TO THE UCM EXTERNAL AUTO/STOP INPUT.

92 —
93 —
94 —
95 —
96 —
97 —
98 —
99 —
100 —
101 —
102 —
103 —
104 —
105 —
106 —
107 —
108 —
109 —
110 —
111 —
112 —
113 —
114 —
115 —
116 —
117 —
118 —
119 —
120 —

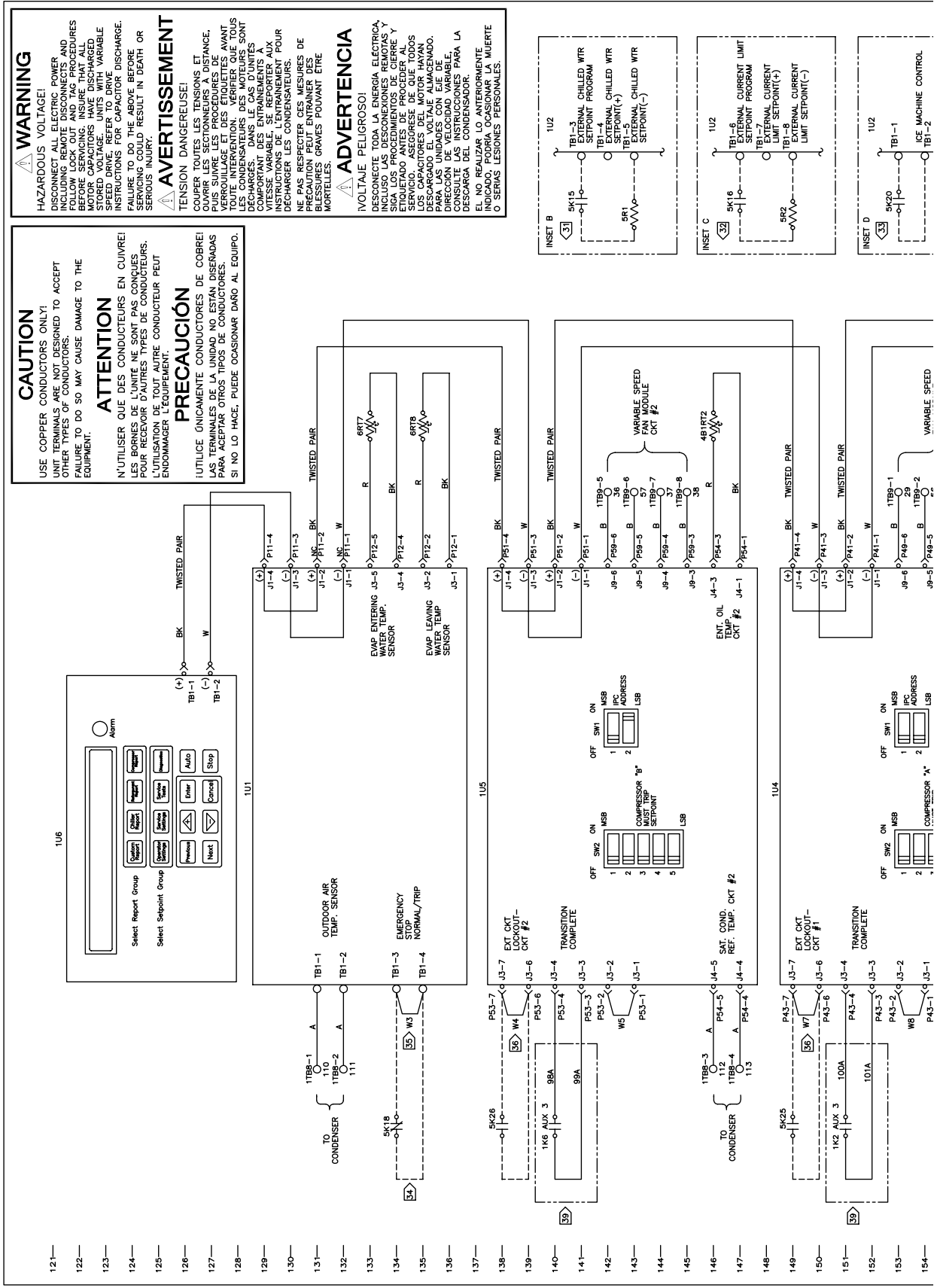

WARNING

HAZARDOUS VOLTAGE!
DISCONNECT ALL ELECTRIC POWER FROM THE UNIT BEFORE YOU FOLLOW LOCK OUT AND TAG PROCEDURES BEFORE SERVICING. INSURE THAT ALL MOTOR CAPACITORS HAVE DISCHARGED. SERVICING MUST BE DONE AT VARIABLE SPEED DRIVE. REFER TO DRIVE INSTRUCTIONS FOR CAPACITOR DISCHARGE. FAILURE TO DO THE ABOVE BEFORE SERVICING COULD RESULT IN DEATH OR SERIOUS INJURY.

AVERTISSEMENT

TENSION DANGEREUSE!
CUTER TOU LES ALIMENTATIONS ET COUVRIR LES SECTIONNEURS A DISTANCE. PUIS SUIVRE LES PROCEDURES DE VERROUILLAGE ET DES ETIQUETTES AVANT DE SERVICER. ASSUREZ-VOUS QUE TOUS LES CONDENSATEURS DES MOTEURS SONT DECHARGES. DANS LE CAS D'UNITES COMPORTANT DES ENTRAINEMENTS A VITESSE VARIABLE, LE SERVICING DOIT ETRE FAIT A VITESSE VARIABLE. SEULEMENT LES INSTRUCTIONS DE L'ENTRAINEMENT POUR DECHARGER LES CONDENSATEURS. NE PAS RESPECTER CES MESURES DE PRECAUTION PEUT ENTRAINER DES BLESSURES GRAVES POUVANT ETRE MORTELLES.

ADVERTENCIA

VOLTAJE PELIGROSO!
DESCONECTE TODA LA ENERGIA ELECTRICA INCLUIDO LAS DESCONEXIONES REMOTAS Y SIGA LOS PROCEDIMIENTOS DE CIERRE Y VERRUILLAJE Y LAS ETIQUETAS DE PROCEDIMIENTOS ANTES DE SERVICIAR. ASEGURESE DE QUE TODOS LOS CAPACITORES DEL MOTOR HAYAN DESCARGADO EL VOLTAJE ALMACENADO. PARA LAS UNIDADES CON VELOCIDAD VARIABLE, EL SERVICIO DEBE HECHO A VELOCIDAD VARIABLE. CONSULTE LAS INSTRUCCIONES PARA LA DESCARGA DEL CONDENSADOR. EL NO REALIZAR LO ANTERIORMENTE INDICADO, PODRIA OCASIONAR LA MUERTE O SERIAS LESIONES PERSONALES.

CAUTION

USE COPPER CONDUCTORS ONLY!
UNIT TERMINALS ARE NOT DESIGNED TO ACCEPT OTHER TYPES OF CONDUCTORS. FAILURE TO DO SO MAY CAUSE DAMAGE TO THE EQUIPMENT.

ATTENTION

N'UTILISER QUE DES CONDUCTEURS EN CUIVRE!
LES BORNES DE L'UNITE NE SONT PAS CONÇUES POUR RECEVOIR D'AUTRES TYPES DE CONDUCTEURS. L'UTILISATION DE TOUT AUTRE CONDUCTEUR PEUT ENDOMMAGER L'EQUIPEMENT.

PRECAUCIÓN

UTILICE ÚNICAMENTE CONDUCTORES DE COBRE!
LAS TERMINALES DE LA UNIDAD NO ESTAN DISEÑADAS PARA ACEPTAR OTROS TIPOS DE CONDUCTORES. SI NO LO HACE, PUEDE OCASIONAR DAÑO AL EQUIPO.

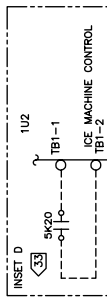
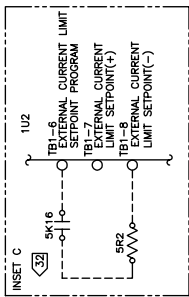
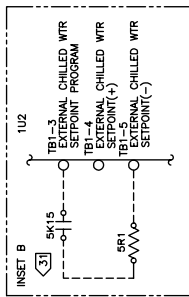

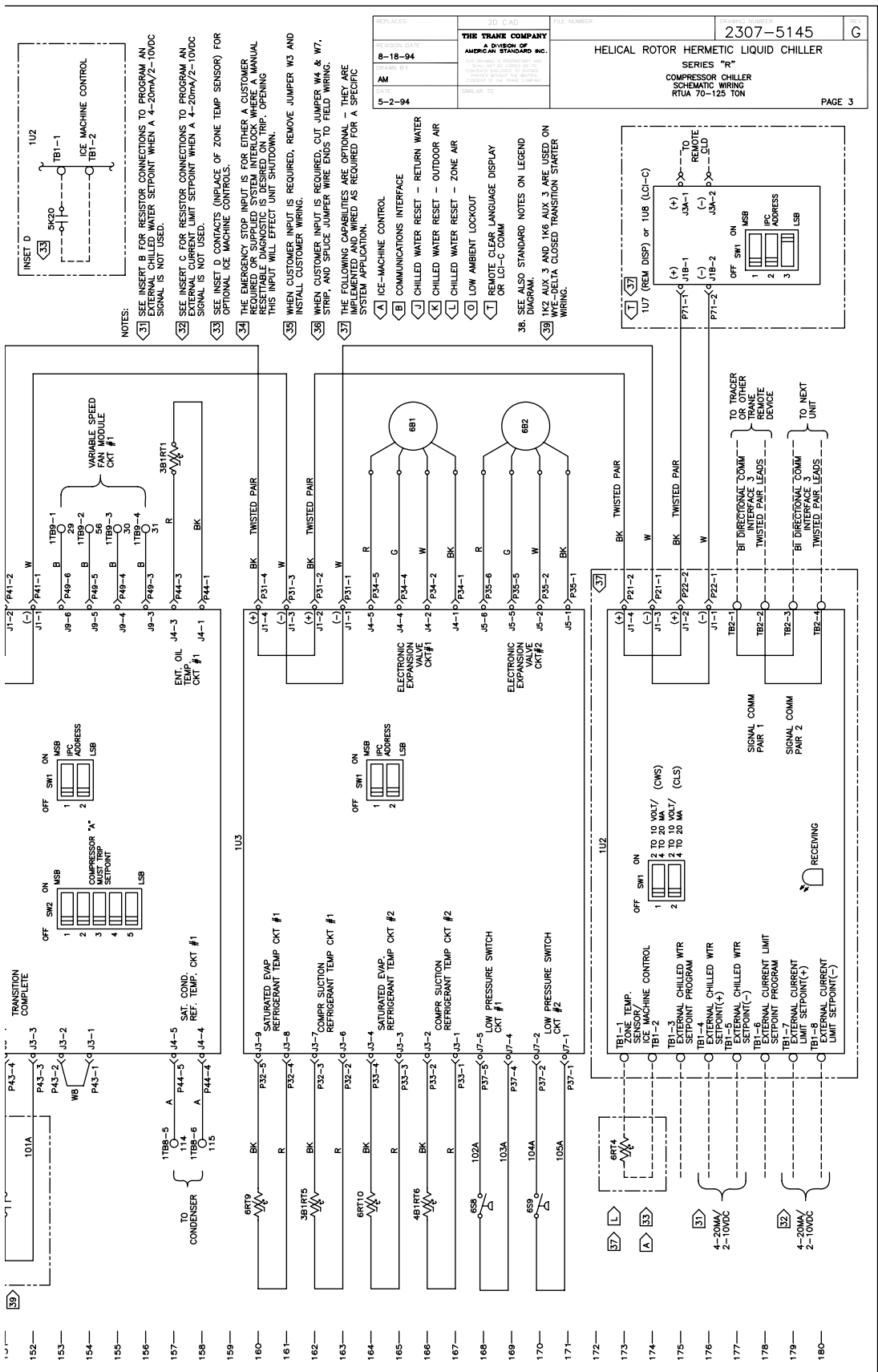

181—
182—
183—
184—
185—
186—
187—
188—
189—
190—
191—
192—
193—
194—
195—
196—
197—
198—
199—
200—
201—
202—
203—
204—
205—
206—
207—
208—
209—
210—

DEVICE DESIGNATION	LEGEND DESCRIPTION	LINE NUMBER
1F15	CONTROL CKT FUSE	65
1F16,1F17	CONTROL POWER TRANS. FUSES	51,52
1K1,1K5	START CONTACTORS	91,99,79,80
1K2,1K6	STOP CONTACTORS	71,82
1K4,1K8	TRANSITION CONTACTORS	91,92
1K3,1K7	SHORTING CONTACTORS	92,83
1R1-16	TRANSITION RESISTORS CKT #1	22,25,26,57-59
1R11-16	TRANSITION RESISTORS CKT #2	33,36,39,57-59
1S1	NON-FUSED DISCONNECT SWITCH	14
1T1	CONTROL POWER TRANSFORMER	63,95,104
1T2	UNDER/OVER VOLTAGE TRANSFORMER	51
1T3-5	CPRSR. CURRENT TRANS CKT #1	21,24,27
1T6-8	CPRSR. CURRENT TRANS CKT #2	32,35,38
1T9	CLD TRANSFORMER	105
1TB1	LINE VOLTAGE TERMINAL BLOCK	14
1TB3,4	TERMINAL STRIP 12V	
1U1	CHILLER MODULE	8,51,66,128
1U2	OPTIONS MODULE	112,173
1U3	EXP. VALVE MODULE (EXV)	103,160
1U4	COMPRESSOR MODULE - CPRSR A	18,91,149
1U4K1A	START RELAY CPRSR A	91
1U4K4-K7	FAN RELAYS CKT #1	96,99
1U4K2	TRANSITION RELAY CPRSR A	91
1U5	COMPRESSOR MODULE-CPRSR B	29,79,138
1U5K1A	START RELAY CPRSR B	79
1U5K4-K7	FAN RELAYS CKT #2	94,97
1U5K2	TRANSITION RELAY CPRSR B	82
1U4Q10	SLIDE VALVE LOAD CKT #1 (TRM4)	94
1U5Q10	SLIDE VALVE LOAD CKT #2 (TRM2)	82
1U5Q11	SLIDE VALVE UNLOAD CKT #1 (TRM4)	83
1U5Q12	SLIDE VALVE UNLOAD CKT #2 (TRM4)	83
1U6	CLEAR LANGUAGE DISPLAY MODULE	107,121
1U7	REMOTE DISPLAY BUFFER MODULE	109,174
1U8	LCI-C COMM MODULE	109,174
3B1	COMPRESSOR A CKT #1	24
3B1L2	STEP LOAD SOLENOID CKT #1 (FIRST STEP)	92
3B1L3	SLIDE VALVE LOAD SOLENOID CKT #1	94
3B1L4	SLIDE VALVE UNLOAD SOLENOID CKT #1	95
3B1S1	HIGH PRESSURE SWITCH CKT #1	91
3B1S2-4	WINDING THERMOSTATS CKT #1	98,99
3B1RT1	EXT. OIL TEMP. SENSOR CKT #1	157
3B1RT5	CPRSR. SUC. RFGT TEMP. SENSOR CKT #1	162

DEVICE DESIGNATION	LEGEND DESCRIPTION	LINE NUMBER
4B1	COMPRESSOR A CKT #2	35
4B1L5	STEP LOAD SOLENOID CKT #2 (FIRST STEP)	80
4B1L6	SLIDE VALVE UNLOAD SOLENOID CKT #2	82
4B1L7	SLIDE VALVE UNLOAD SOLENOID CKT #2	82
4B1S2	HIGH PRESSURE SWITCH CKT #2	83
4B1S3-7	WINDING THERMOSTATS CKT #2	86-87
4B1RT2	EXT. OIL TEMP. SENSOR CKT #2	146
4B1RT6	CPRSR. SUC. RFGT TEMP. SENSOR CKT #2	166
5B1	CHILLED WATER PUMP MOTOR	4
5K1	CHILLER WATER PUMP STARTER	7,76
5K2	ALARM RELAY	72
5K3	ALARM RELAY	73
5K4	UNIT RUNNING RELAY	74
5K5	MAX CAPACITY OUTPUT RELAY	75
5K15	EXT. CHILLED WTR SETPOINT RELAY	141
5K16	EXT. CURRENT LIMIT SETPOINT RELAY	147
5K20	CHILLER STOP RELAY	153
5K25	EXT. CHILLED WTR SETPOINT RELAY	153
5K26	EXT. CKT LOCKOUT RELAY - CK#1	139
5K26	EXT. CKT LOCKOUT RELAY - CK#2	138
5R1	EXT. CHILLED WATER SETPOINT RESISTOR	143
5R2	EXT. CURRENT LIMIT SETPOINT RESISTOR	149
5S2	CHILLED WATER SYSTEM DEMAND SWITCH	71
6B1	ELECTRONIC EXPANSION VALVE CKT #1	165
6B2	ELECTRONIC EXPANSION VALVE CKT #2	169
6RT4	ZONE TEMP SENSOR	173
6RT7	EVAP. EXT. WTR TEMP. SENSOR	133
6RT8	EVAP. LVC. WTR TEMP. SENSOR	135
6RT9	SAT. EVAP. RFGT TEMP. SENSOR CKT #1	160
6RT10	SAT. EVAP. RFGT TEMP. SENSOR CKT #2	164
6S10	OIL COOLER SOLENOID VALVE CKT #1	90
6S11	OIL COOLER SOLENOID VALVE CKT #2	76,81

AREA	CONTROL LOCATION	DEVICE PREFIX	LOCATION CODE
1	REMOTE EVAPORATOR		
2	FIRST CIRCUIT COMPR.		
3	SECOND CIRCUIT COMPR.		
4	CUSTOMER PROVIDED		
5			
6	UNIT MOUNTED		

CAUTION
USE COPPER CONDUCTORS ONLY!
UNIT TERMINALS ARE NOT DESIGNED TO ACCEPT OTHER TYPES OF CONDUCTORS.
FAILURE TO DO SO MAY CAUSE DAMAGE TO THE EQUIPMENT.

ATTENTION
N'UTILISER QUE DES CONDUCTEURS EN CUIVRE!
LES BORNES DE L'UNITÉ NE SONT PAS CONÇUES POUR RECEVOIR D'AUTRES TYPES DE CONDUCTEURS.
L'UTILISATION DE TOUT AUTRE CONDUCTEUR PEUT ENDOMMAGER L'EQUIPEMENT.

PRECAUCIÓN
¡UTILICE ÚNICAMENTE CONDUCTORES DE COBRE!
LAS TERMINALES DE LA UNIDAD NO ESTÁN DISEÑADAS PARA ACEPTAR OTROS TIPOS DE CONDUCTORES.
SI NO LO HACE, PUEDE OCASIONAR DAÑO AL EQUIPO.

WARNING
HAZARDOUS VOLTAGE!
DISCONNECT ALL ELECTRIC POWER INCLUDING REMOTE DISCONNECTS AND UNIT TERMINALS BEFORE WORKING ON THE UNIT. ALL MOTOR CAPACITORS HAVE DISCHARGED CAPACITORS. ALWAYS FOLLOW THE INSTRUCTIONS FOR CAPACITOR DISCHARGE FAILURE TO DO THE ABOVE BEFORE SERVICING COULD RESULT IN DEATH OR SERIOUS INJURY.

AVERTISSEMENT
TENSION DANGEREUSE!
COUPER TOUTES LES TENSIONS ET Y COMPRIS LES DÉCONNECTS À DISTANCE, AVANT DE TRAVAILLER SUR L'UNITÉ. TOUS LES CONDENSATEURS DE MOTEUR ONT DES CONDENSATEURS DÉCHARGÉS. TOUJOURS SUIVRE LES PROCÉDÉS DE DÉCHARGE DES CONDENSATEURS. LE NON-RESPECT DE CES MESURES PEUT ENTRAÎNER DES BLESSURES GRAVES POUVANT ÊTRE MORTELLES.

ADVERTENCIA
¡VOLTAJE PELIGROSO!
DESCONECTE TODA LA ENERGÍA ELÉCTRICA, INCLUIDOS LOS DESCONNECTS A DISTANCIA Y LAS TERMINALES DE LA UNIDAD, ANTES DE TRABAJAR EN LA UNIDAD. TODOS LOS CONDENSADORES DE MOTOR TIENEN CONDENSADORES DESCARGADOS. SIEMPRE SIGA LOS PROCEDIMIENTOS DE CIERRE Y ETIQUETADO ANTES DE PROCEDER AL SERVICIO. SEGUROSE DE QUE TODOS LOS CONDENSADORES DE MOTOR HAYAN SIDO DESCARGADOS ANTES DE TRABAJAR EN LA UNIDAD. EL VOLTAJE ALMACENADO EN LAS UNIDADES CON EJE DE DIRECCION DE VELOCIDAD VARIABLE, PUEDE SER PELIGROSO. PARA LA DESCARGA DEL CONDENSADOR, EL NO REALIZAR LO ANTERIORMENTE INDICADO, PODRIA OCASIONAR LA MUERTE O SERIAS LESIONES PERSONALES.

- NOTES:
- UNLESS OTHERWISE NOTED, ALL SWITCHES ARE SHOWN AT 25° C (77° F) AT ATMOSPHERIC PRESSURE. SWITCHES OPERATED WITH ALL UTILITIES TURNED OFF, AND AFTER A NORMAL SHUTDOWN HAS OCCURRED.
 - DASHED LINES INDICATE RECOMMENDED FIELD WIRING BY OTHERS. DASHED LINE ENCLISURES CONTAIN WIRING PROVIDED BY THE FIELD. DASHED LINE ENCLISURES INDICATE ALTERNATE WIRING. SOLID LINES INDICATE WIRING BY TRANE CO.
 - NUMBERS TO THE RIGHT OF THE SYMBOLS ALONG WITH THE LOCATION OF THE CONTACTS BY LINE NUMBER, AN UNDERLINED NUMBER INDICATES CONTACTS THAT ARE IN CONTACT. AN OPEN ARROWHEAD BELOW THE LINE NUMBER POINTING UPWARD INDICATES A CONTACT WHICH BEGINS TIMING WHEN ENERGIZED.

UNIT SEQUENCE OF OPERATION

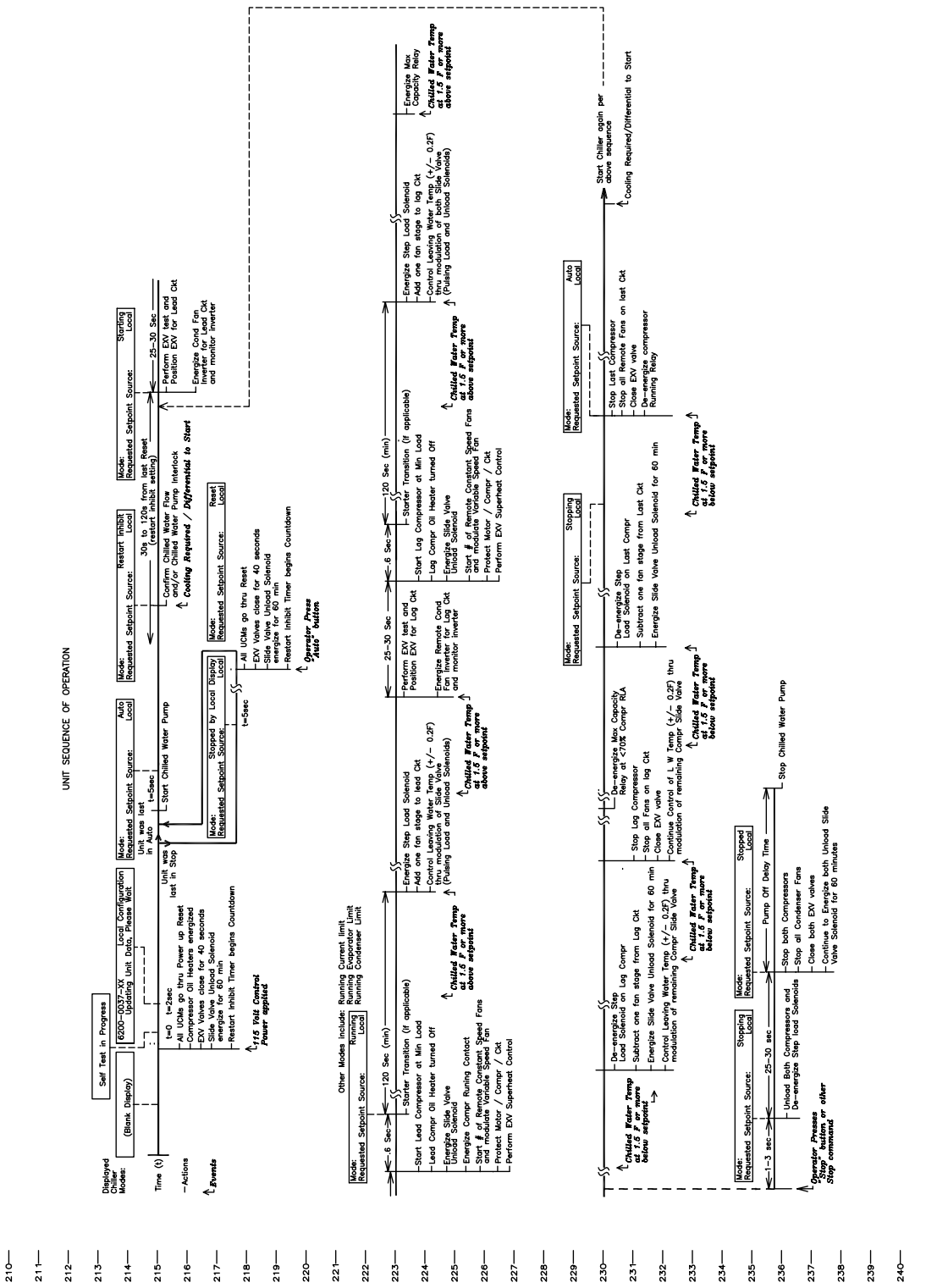

WARNING
HAZARDOUS VOLTAGE!

DISCONNECT ALL ELECTRIC POWER INCLUDING REMOTE DISCONNECTS AND FOLLOW LOCK OUT AND TAG PROCEDURES BEFORE SERVICING. INSURE THAT ALL MOTOR CAPACITORS HAVE DISCHARGED STORED VOLTAGE. UNITS WITH VARIABLE SPEED DRIVE, REFER TO DRIVE INSTRUCTIONS FOR CAPACITOR DISCHARGE. FAILURE TO DO THE ABOVE BEFORE SERVICING COULD RESULT IN DEATH OR SERIOUS INJURY.

AVERTISSEMENT
TENSION DANGEREUSE!

COUPER TOUTES LES TENSIONS ET OUVRIR LES SECTIONNEURS A DISTANCE, PUIS SUIVRE LES PROCEDURES DE VERROUILLAGE ET DES ETIQUETTES AVANT TOUTE INTERVENTION. VERIFIER QUE TOUTS LES CONDENSATEURS DES MOTEURS SONT DECHARGES. DANS LE CAS D'UNITES COMPORTANT DES ENTRAÎNEMENTS A VITESSE VARIABLE, SE REPORTER AUX INSTRUCTIONS DE L'ENTRAÎNEMENT POUR DECHARGER LES CONDENSATEURS.

NE PAS RESPECTER CES MESURES DE PRECAUTION PEUT ENTRAÎNER DES BLESSURES GRAVES POUVANT ETRE MORTELLES.

ADVERTENCIA
¡VOLTAJE PELIGROSO!

DESCONECTE TODA LA ENERGÍA ELÉCTRICA, INCLUIDO LAS DESCONEXIONES REMOTAS Y SIGA LOS PROCEDIMIENTOS DE CIERRE Y ETIQUETADO ANTES DE PROCEDER AL SERVICIO. ASEGURESE DE QUE TODOS LOS CAPACITORES DEL MOTOR HAYAN DESCARGADO EL VOLTAJE ALMACENADO. PARA LAS UNIDADES CON EJE DE DIRECCIÓN DE VELOCIDAD VARIABLE, CONSULTE LAS INSTRUCCIONES PARA LA DESCARGA DEL CONDENSADOR.

EL NO REALIZAR LO ANTERIORMENTE INDICADO, PODRÍA OCASIONAR LA MUERTE O SERIAS LESIONES PERSONALES.

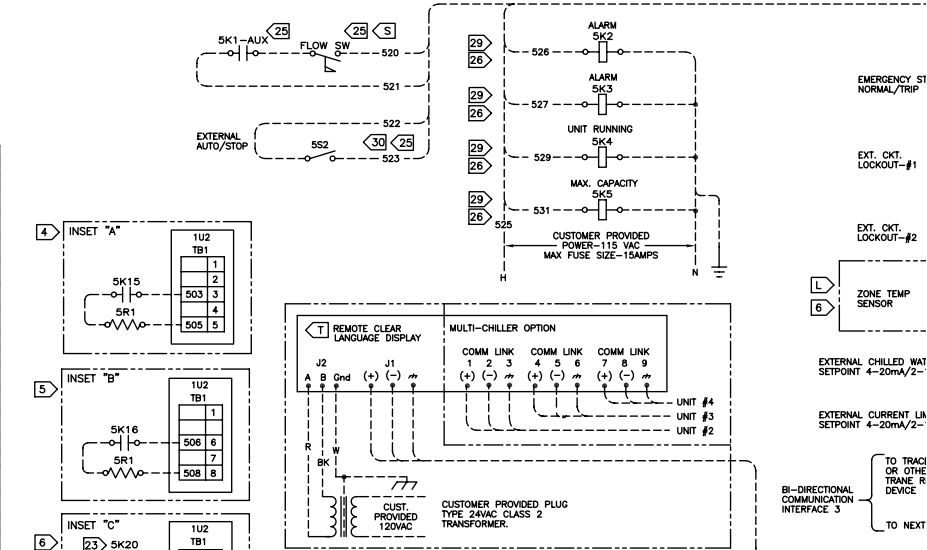
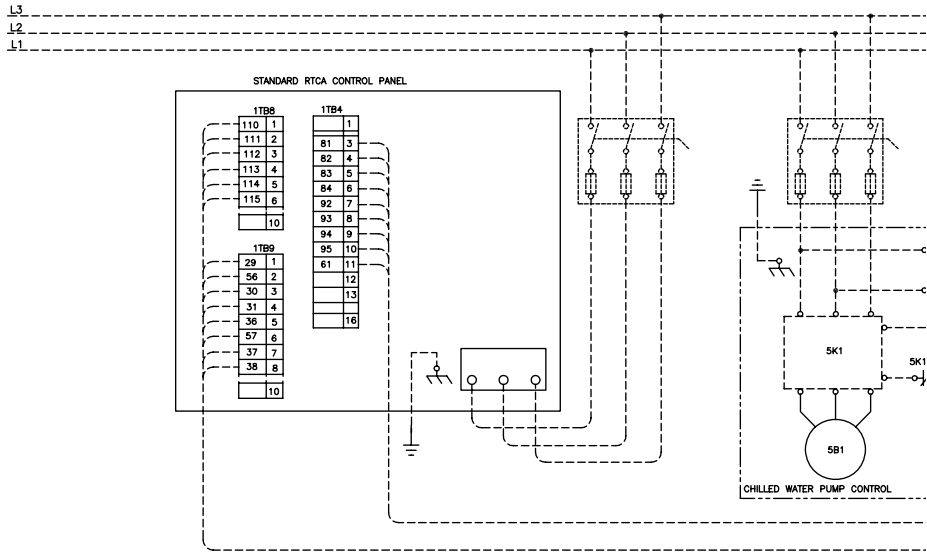

CUSTOMER WIRE SELECTION TABLE			
POWER WIRE SELECTION TO DISCONNECT SWITCH(1S1)			
UNIT SIZE	UNIT VOLTAGE	DISCONNECT SWITCH SIZE	CONNECTOR WIRE RANGE
70	200,230/60	400	(1)3/0-500 MCM (1)3/0-250 MCM
	220,346/50	225	(1)2/0-300 MCM
	380,415/50 380,460,575/60	150	(1)#4-4/0
80	200,230/60 220/50	400	(1)3/0-500 MCM (1)3/0-250 MCM
	346,400/50 380/60	225	(1)2/0-300 MCM
	460,575/60	150	(1)#4-4/0
90	200/60	400	(2)4/0-350 MCM
	230/60 220/50	400	(1)3/0-500 MCM (1)3/0-250 MCM
	346/50 380/60	225	(1)2/0-300 MCM
100	200/60	600	(2)4/0-350 MCM
	220,346/50 230,380/60	400	(1)3/0-500 MCM (1)3/0-250 MCM
	380,415/50 460,575/60	225	(1)2/0-300 MCM
110	200,230/60	600	(2)4/0-350 MCM
	220,346/50 380/60	400	(1)3/0-500 MCM (1)3/0-250 MCM
	380,415/50 460,575/60	225	(1)2/0-300 MCM
120	200/60	600	(2)350-500 MCM
	220,50	400	(2)4/0-350 MCM
	230/60 346,400/50 380,460/60	400	(1)3/0-500 MCM (1)3/0-250 MCM
575/60	225	(1)2/0-300 MCM	

UNIT SIZE	UNIT VOLTAGE	TERMINAL BLOCK SIZE	CONNECTOR WIRE RANGE
70 - 110	575/60		
70 - 90	480/60, 380,415/50	175	#14 TO 2/0
70 - 80	380/60		
70	346/50		
125	575/60		
100 - 1125	480/60, 380,415/50	335	#6 TO 360 MCM
90 - 125	380/60		
70 - 80	200,230/60		
90 - 125	346/50		
70 - 90	220/50		
90 - 125	200,230/60	760	#2 TO 500 MCM
100 - 125	220/50		

WIRE SIZE	MAXIMUM LENGTH FOR SENSOR LEADS
14 AWG	5000 FT
16 AWG	2000 FT
18 AWG	1000 FT

FUSE DESCRIPTION	UNIT SIZE	UNIT VOLTAGE	FUSE TYPE	FUSE SIZE
CONTROL CIRCUIT FUSE (1F15)	ALL	ALL	CLASS CC (600V)	10 AMP
POWER CONTROL TRANSFORMER FUSE (1F16-1F17)		200/230V, 220V	CLASS CC (600V)	5 AMP
		346,380/415	CLASS CC (600V)	3 AMP
		380,460,575V	CLASS CC (600V)	3 AMP
OPM & MSCP FUSE (1U1F1,1U4F1 & 1USF1)	ALL	ALL	BUSS GMC-1/4 LITTLEFUSE 259.250	0.25 AMP 5x20mm
EXV FUSE (1U3F1)	ALL	ALL	BUSS GMC-3/10 LITTLEFUSE 259.300	0.30 AMP 5x20mm
CSR FUSE (1U2F2)	ALL	ALL	BUSS GMC-2/10 LITTLEFUSE 259.200	0.20 AMP 5x20mm

- NOTES:
- DASHED LINES INDICATE RECOMMENDED FIELD WIRING BY OTHERS. PHANTOM LINES INDICATE ALTERNATE CIRCUITRY OR AVAILABLE SALES OPTION. CHECK SALES ORDER TO DETERMINE IF WIRING IS REQUIRED FOR SPECIFIC OPTIONS.
 - ALL THREE PHASE MOTORS SUPPLIED WITH THE UNIT ARE PROTECTED UNDER PRIMARY SINGLE PHASE FAILURE CONDITIONS.
 - CAUTION - DO NOT ENERGIZE UNIT UNTIL CHECK OUT AND START-UP PROCEDURES HAVE BEEN COMPLETED.
 - SEE INSET "A" FOR RESISTOR CONNECTIONS TO PROGRAM AN EXTERNAL CHILLED WATER SETPOINT WHEN 4 - 20 mA OR 2 - 10 VDC SIGNAL IS NOT USED. SEE THE OPERATORS MANUAL FOR RESISTOR VALUES.
 - SEE INSET "B" FOR RESISTOR CONNECTIONS TO PROGRAM AN EXTERNAL CURRENT LIMIT SETPOINT WHEN 4 - 20 mA OR 2 - 10 VDC SIGNAL IS NOT USED. SEE THE OPERATORS MANUAL FOR RESISTOR VALUES.
 - SEE INSET "C" FOR CONTACTS (IN PLACE OF THE ZONE TEMP. SENSOR) FOR OPTIONAL ICE MACHINE CONTROL - OPTION "A".
 - THE FOLLOWING CAPABILITIES ARE OPTIONAL - THEY ARE IMPLEMENTED AND WIRED AS REQUIRED FOR A SPECIFIC SYSTEM APPLICATION.
 - [A] ICE-MACHINE CONTROL
 - [B] COMMUNICATIONS INTERFACE
 - [D] WYE-DELTA CLOSED TRANSITION STARTER.
 - [E] CONTROL POWER TRANSFORMER.
 - [H] UNIT DISCONNECT, NON-FUSED
 - [J] CHILLED WATER RESET - RETURN WATER
 - [K] CHILLED WATER RESET - OUTDOOR AIR
 - [O] LOW AMBIENT LOCKOUT
 - [S] CHILLED WATER FLOW SWITCH (NOT REQUIRED FOR CHILLER PROTECTION)
 - [T] REMOTE CLEAR LANGUAGE DISPLAY (BUFFER FOR DISPLAY LOCATED IN UNIT CONTROL PANEL)

- WIRING AND CONT.
- [20] ALL FIELD WIRING I CODE (NEC), STATE OTHER COUNTRIES APPLY.
 - [23] CUSTOMER SUPPLIE 45mA RESISTIVE L
 - [24] 30 VOLT OR LESS CIRCUITS, OR MIX #14-18 AWG, SEE
 - [25] MINIMUM PILOT DU
 - [26] FIELD WIRED ELECT TERMINALS

1U1-TB4-1,2	11
1U1-TB4-3	11
1U1-TB4-4,4	11
1U1-TB4-6,7	11
1U1-TB4-8,9	11
1U1-TB4-10,11	11
 - [27] * STANDARD PILOT IF EXTERNAL CIRCU AND SPLICE 45A A FOR CIRCUIT #2 C CUT ENDS OF THE
 - [28] AS SHIPPED 380/4 415 VOLT OPERATE RE-CONNECT AS S SETTING MENU OF
 - [29] K1, K2, K3 RELAY SEE INSTALLATION, IS SHOWN.
 - [30] CHILLED WATER PU IS REQUIRED TO CHILLER OPERATION DEMAND SWITCH (S
 - [31] RECOMMEND USING WITH DRAIN WIRE (I 3 RUNS OF 2 CON 1000 FT. (BELDEN CIRCUITS.

REVISED	2D CAD	REVISION	2307-6008	G
DATE	11-12-96	DESCRIPTION	HELICAL ROTOR HERMETIC LIQUID CHILLER	
AM	5-2-94	BY	SERIES "R" COMPRESSOR / CHILLER FIELD WIRING RTUA 70-125 TON WITH TRANE RTCA CONDENSER	
THE TRANE COMPANY A DIVISION OF AMERICAN STANDARD INC.				

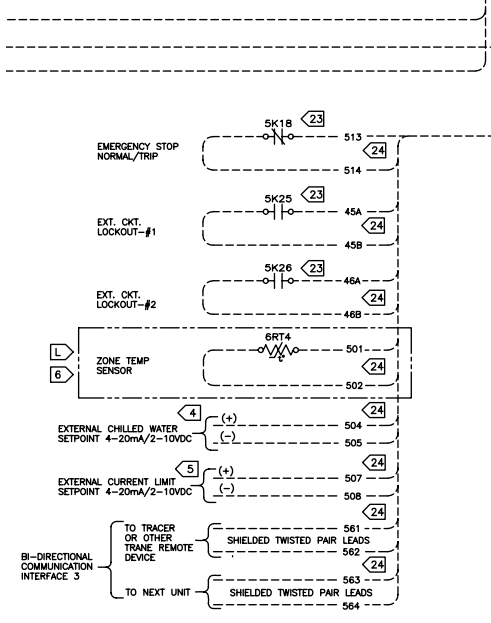
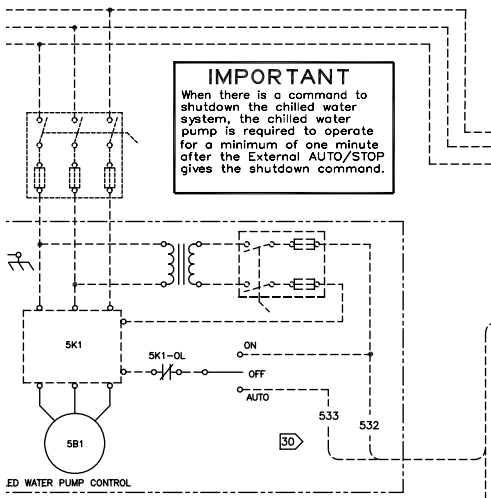

- WIRING AND CONTACT REQUIREMENTS:**
- ALL FIELD WIRING MUST BE IN ACCORDANCE WITH THE NATIONAL ELECTRICAL CODE (NEC), STATE AND LOCAL REQUIREMENTS, OUTSIDE THE UNITED STATES, OTHER COUNTRIES APPLICABLE NATIONAL AND/OR LOCAL REQUIREMENTS SHALL APPLY.
 - CUSTOMER SUPPLIED CONTACTS MUST BE COMPATIBLE WITH DRY CIRCUIT 120V, 45mA RESISTIVE LOAD, SILVER OR GOLD PLATED CONTACTS ARE RECOMMENDED.
 - 30 VOLT OR LESS CIRCUIT, DO NOT RUN IN CONDUIT WITH HIGHER VOLTAGE CIRCUITS, OR MIX WITH HIGH VOLTAGE WIRING IN THE CONTROL PANEL. USE #14-18 AWG, SEE SELECTION TABLE.
 - MINIMUM PILOT DUTY CONTACT RATING AT 115 VAC; 6.9VA INRUSH, 1.3VA SEALED.
 - FIELD WIRING ELECTRICAL LOADING IS NOT TO EXCEED THE FOLLOWING RATINGS:

TERMINALS	DEVICE	VOLTAGE	SEALED VA	INRUSH VA
1U1-TB4-1,2	1U1K1,NO	115	180	1150*
1U1-TB4-3	1U1K1,NC	115	180	1150*
1U1-TB4-5,4	1U1K2,NO	115	180	1150*
1U1-TB4-6,7	1U1K3,NC	115	180	1150*
1U1-TB4-8,9	1U1K2,NO	115	250	1150*
1U1-TB4-10,11	1U1K3,NC	115	180	1150*

- * STANDARD PILOT DUTY RATING (35% POWER FACTOR).
- IF EXTERNAL CIRCUIT LOCKOUT IS USED ON CKT 1 CUT JUMPER W7 ON CIRCUIT #1 AND SPlice 45A AND 45B TO THE INDIVIDUAL CUT ENDS OF THE JUMPER. FOR CIRCUIT #2 CUT JUMPER W4 AND SPlice 46A AND 46B TO THE INDIVIDUAL CUT ENDS OF THE JUMPER.
 - AS SHIPPED 380/415 VOLT UNIT TRANSFORMER 1T1-(OPTIONAL) IS WIRING FOR 415 VOLT OPERATION, IF UNIT IS TO BE OPERATED ON A 380 VOLT POWER SUPPLY, RE-CONNECT AS SHOWN IN INSET 'D'. REPROGRAM UNIT LINE VOLTAGE IN SERVICE SETTING MENU OF CLEAR LANGUAGE DISPLAY FROM 415 TO 380.
 - K1, K2, K3 RELAY OUTPUTS CAN BE PROGRAMMED TO PERFORM ALTERNATE FUNCTIONS. SEE INSTALLATION, OPERATION, AND MAINTENANCE MANUAL FOR DETAILS, FUNCTION #1 IS SHOWN.
 - CHILLED WATER PUMP CONTROL FROM TRANE UNIT UCM MODULE, CHILLED WATER PUMP IS REQUIRED TO OPERATE A MINIMUM OF ONE MINUTE AFTER A COMMAND TO TERMINATE CHILLER OPERATION (UCM WILL PROVIDE TIME DELAY CONTACTS). CHILLED WATER SYSTEM DEMAND SWITCH (5S2) IS CONNECTED TO THE UCM EXTERNAL AUTO/STOP INPUT.

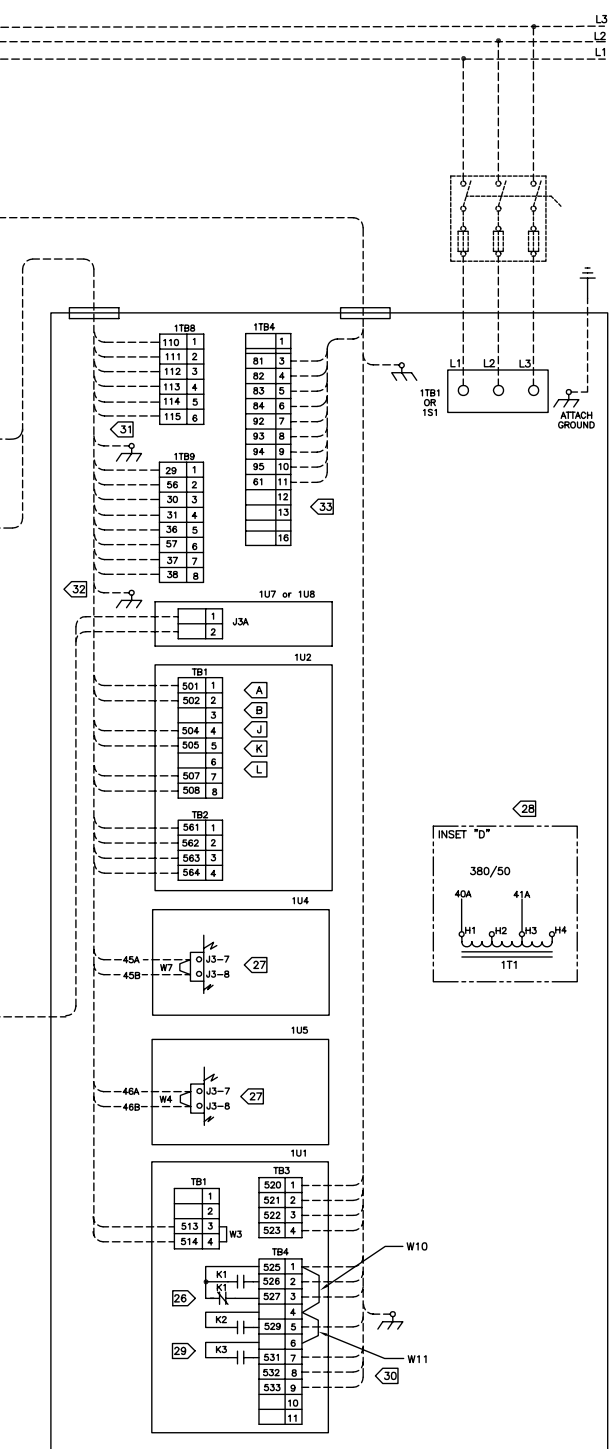

- RECOMMEND USING 1 RUN OF 8 CONDUCTOR #22 AWG 300V 80° C, 100% SHIELDED WITH DRAIN WIRE (BELDEN 9305 OR EQUIVALENT), MAX LENGTH FOR #22 IS 500 FT. USE 4 RUNS OF 2 CONDUCTOR #18 AWG 100% SHIELDED WITH DRAIN WIRE FOR RUNS UP TO 1000 FT. (BELDEN 8760 OR EQUIVALENT). DO NOT RUN IN CONDUIT WITH HIGHER VOLTAGE CIRCUITS.
- 9 WIRES, 115 VAC CIRCUIT. USE #16 AWG MINIMUM.

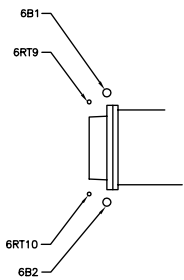

DETAIL A
RTUA 110 & 125 TON

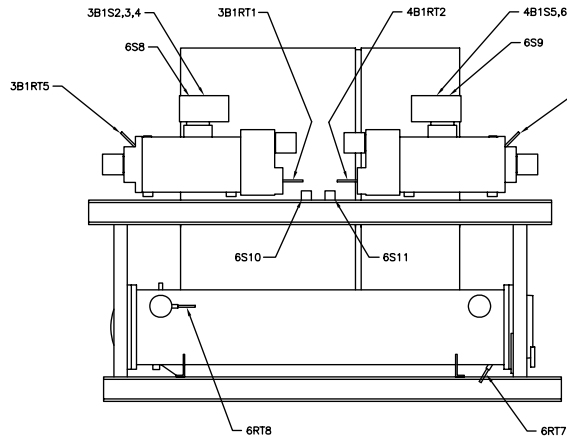
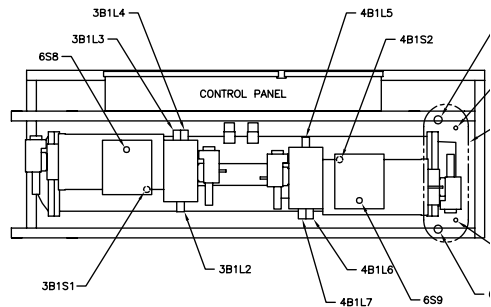

RTUA 70 - 100 TON

DETAIL OF CONTROL PANEL W/STAR-DELTA START

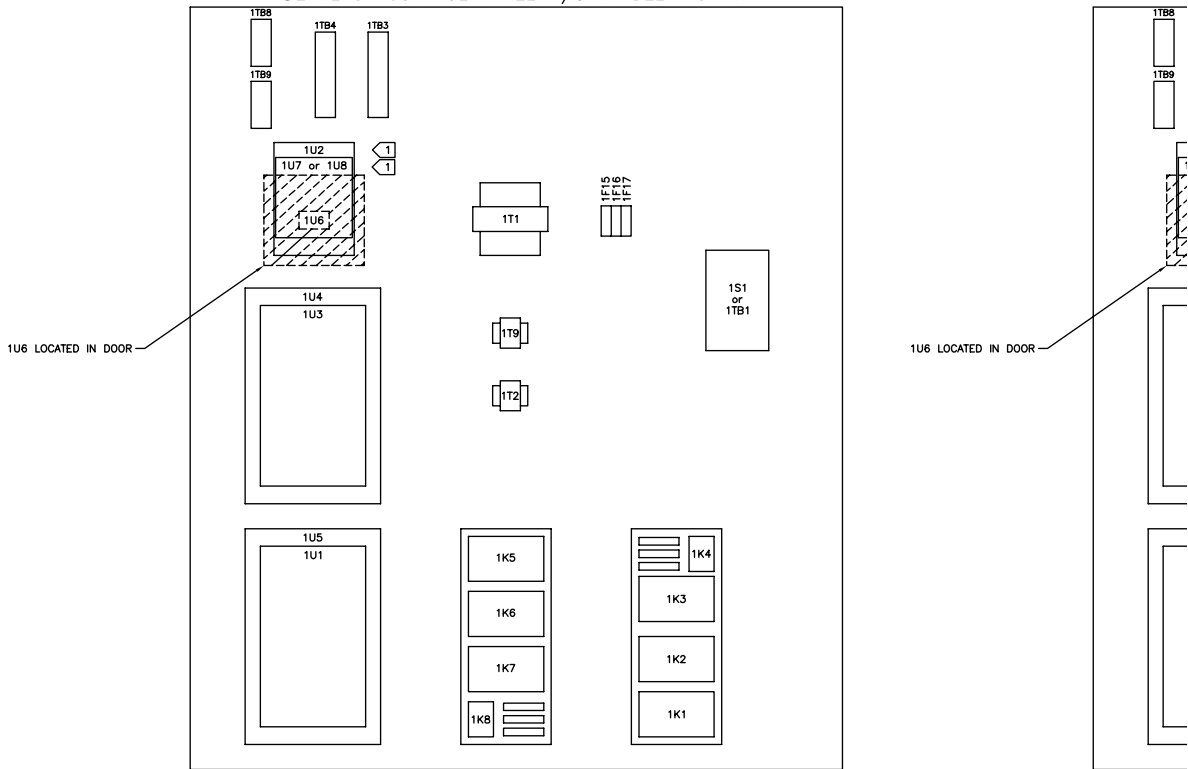

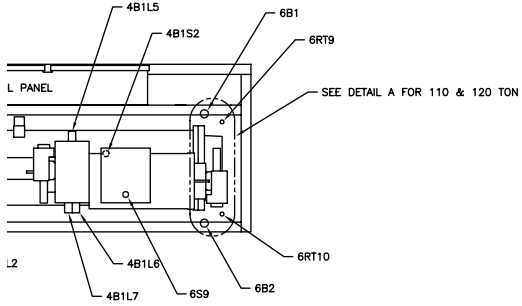

REPLACES	3D CAD	FILE NUMBER	DRAWING NUMBER	REV.
REVISION DATE	THE TRANE COMPANY A DIVISION OF AMERICAN STANDARD INC.		2307-6009	D
DRAWN BY	HELICAL ROTOR HERMETIC LIQUID CHILLER			
DATE	RTUA 70-125 TON			
	COMPONENT LOCATION			
	SMALLER TO			

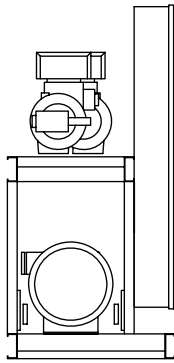
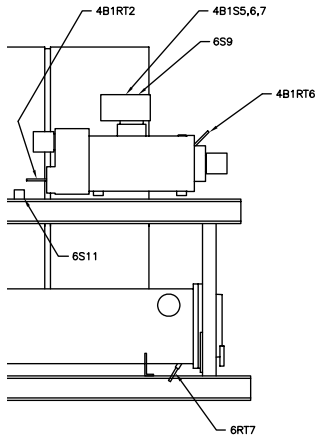

- 100 TON

DETAIL OF CONTROL PANEL W/X-LINE START

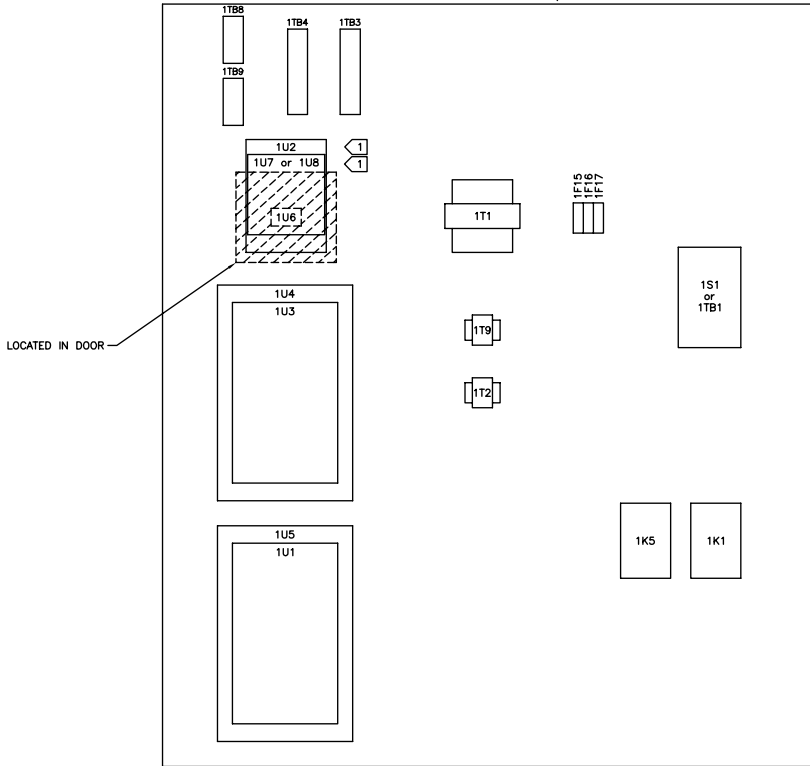

◁ 1 ITEM IS OPTIONAL.

HAZARDOUS VOLTAGE!
DISCONNECT ALL ELECTRIC POWER INCLUDING REMOTE DISCONNECTS AND REMOTE SERVICE SWITCHES BEFORE SERVICING. CAPACITORS HAVE DISCHARGED CAPACITORS. SERVICING WITH VARIABLE SPEED DRIVE REFER TO DRIVE INSTRUCTIONS FOR CAPACITOR DISCHARGE. FAILURE TO DO THE ABOVE BEFORE SERVICING WILL RESULT IN DEATH OR SERIOUS INJURY.

AVERTISSEMENT
TENSION DANGEREUSE!
COUPER TOUTES LES TENSIONS ET OUVRIER LES SECTIONNEURS A DISTANCE, Y COMPRIS LES SECTIONNEURS REMOTES ET LES SERVICE SWITCHES AVANT TOUTE INTERVENTION. VERIFIER QUE TOUTS LES CONDENSATEURS DES MOTEURS SONT DECHARGES AVANT LE SERVICE. SERVICER AVEC UN MOTEUR A VITESSE VARIABLE, SE REFERER AUX INSTRUCTIONS DE L'ENTRAÎNEMENT POUR LE CONDENSATEUR. L'OMISSION DE CECI PEUT RESULTER EN BLESSURES GRAVES POUVANT ETRE MORTELLES.

ADVERTENCIA
VOLTAJE PELIGROSO!
DESCONECTE TODA LA ENERGIA ELECTRICA, INCLUIDO LAS DESCONEXIONES REMOTAS Y LOS SERVICE SWITCHES ANTES DE PROCEDER AL SERVICIO. ASEGURESE DE QUE TODOS LOS CAPACITORES DEL MOTOR HAYAN SIDO DESCARGADOS ANTES DEL SERVICIO. SERVICIAR CON UN MOTOR DE VELOCIDAD VARIABLE, CON ELIJE DE DIRECCION DE LAS INSTRUCCIONES PARA LA DESCARGA DEL CONDENSADOR. LA OMISION DE ESTO PODRIA CAUSAR LESIONES PERSONALES.

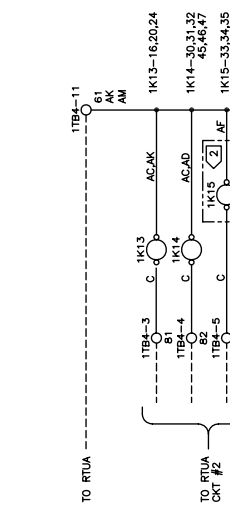
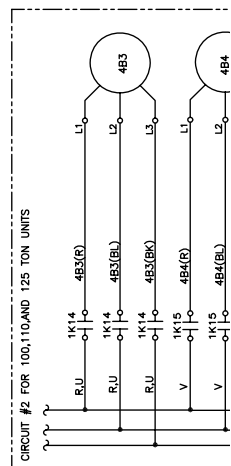
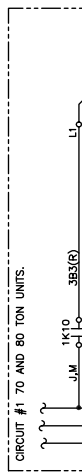
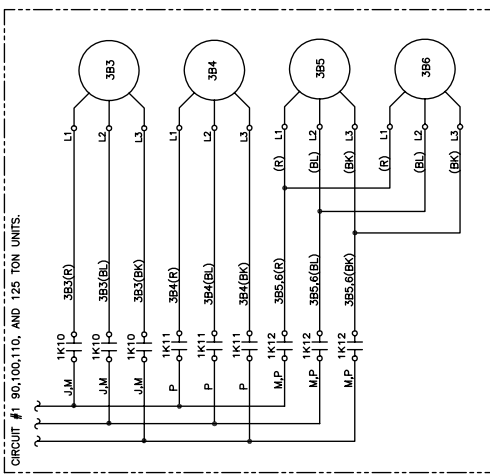
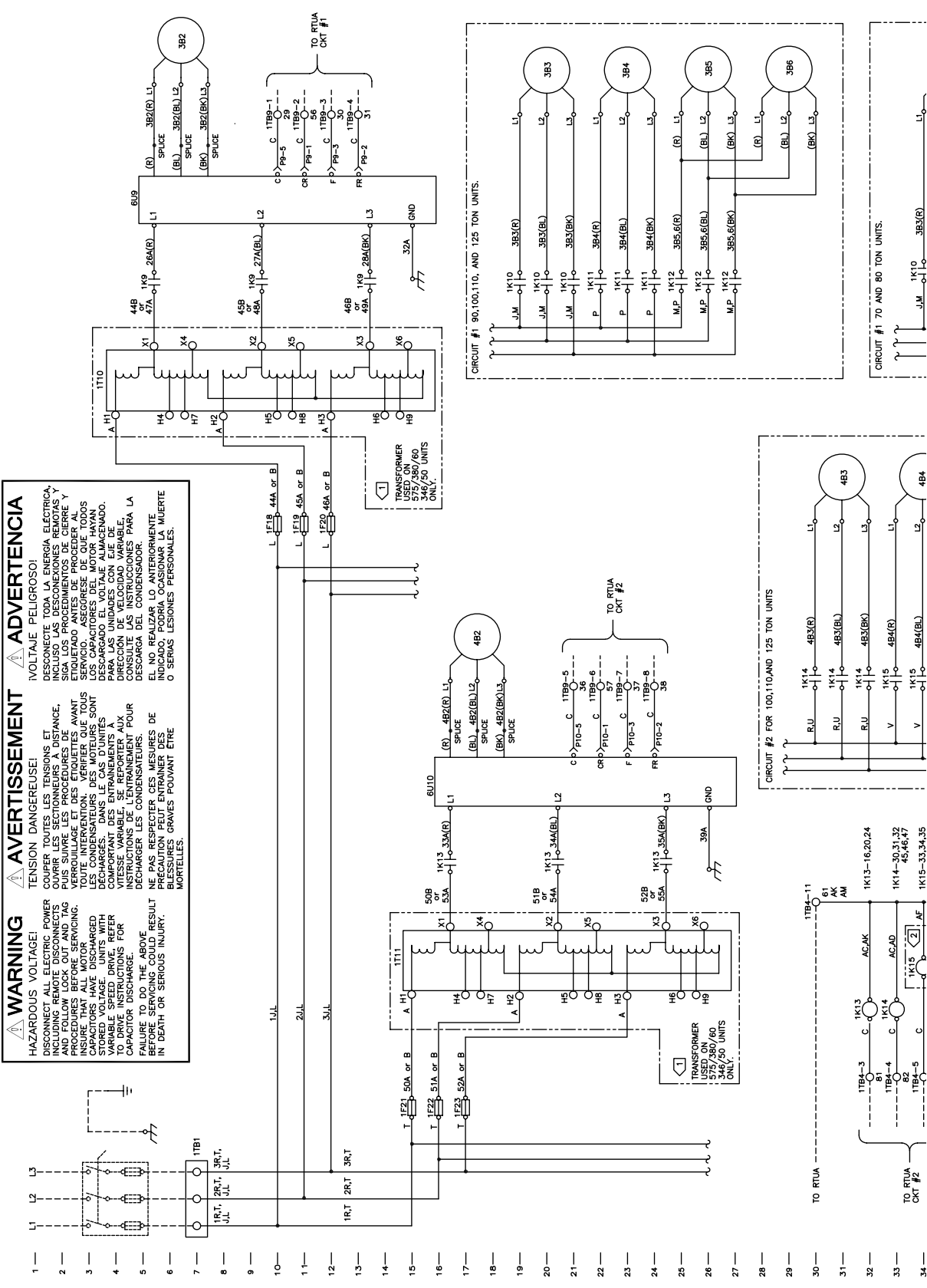

- 1 —
- 2 —
- 3 —
- 4 —
- 5 —
- 6 —
- 7 —
- 8 —
- 9 —
- 10 —
- 11 —
- 12 —
- 13 —
- 14 —
- 15 —
- 16 —
- 17 —
- 18 —
- 19 —
- 20 —
- 21 —
- 22 —
- 23 —
- 24 —
- 25 —
- 26 —
- 27 —
- 28 —
- 29 —
- 30 —
- 31 —
- 32 —
- 33 —
- 34 —

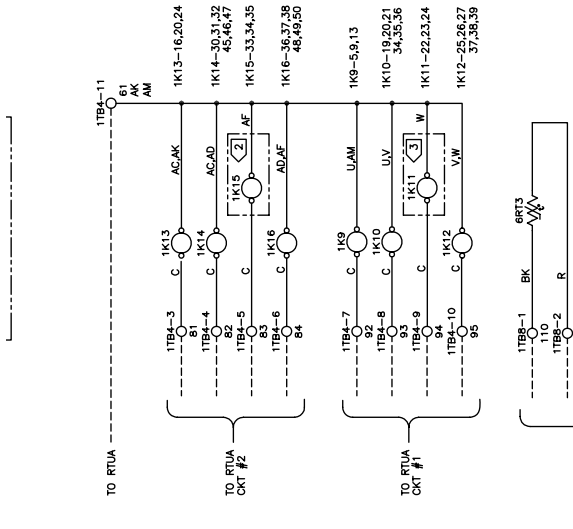
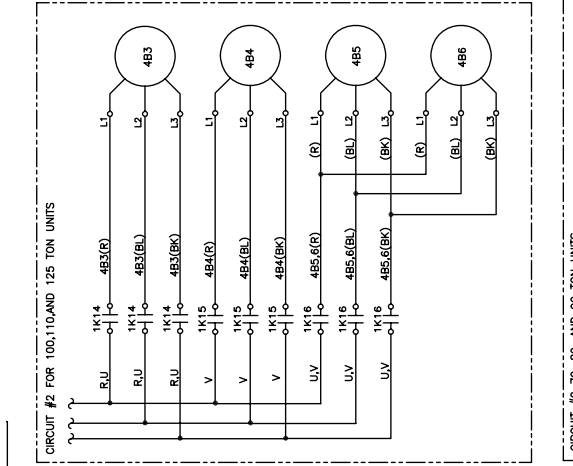
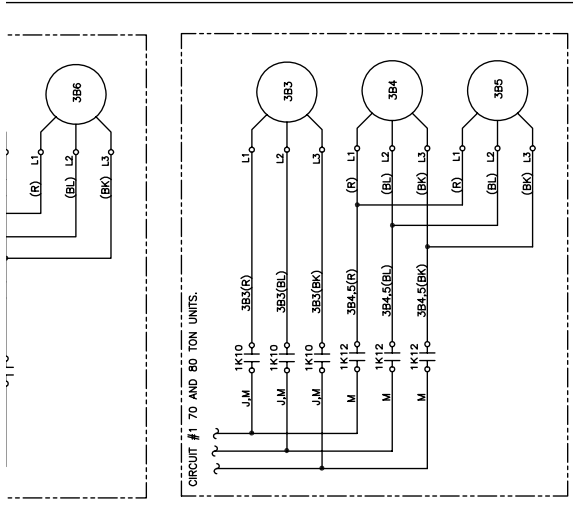

REVISED	20 CAD	DRAWING NUMBER	2307-5147
DESIGN DATE	THE TRANE COMPANY A DIVISION OF AMERICAN STANDARD INC.	TITLE	HELICAL ROTOR HERMETIC LIQUID CHILLER
DRAWN BY	AM	SERIES "R"	REMOTE AIR COOLED CONDENSER SCHEMATIC WIRING-L-L-W AMBIENT RTCA 70-125 TON
DATE	3-29-94	REVISION TO	

DEVICE DESIGNATION	LEGEND	DESCRIPTION	LINE NUMBER
1TB1		LINE VOLTAGE TERMINAL BLOCK	7
1TB4		TERMINAL STRIP 115V	
1TB4-9		TERMINAL STRIP 24V	4
1TB4-9		AUTO-TRANSFORMER CKT #1	15
1TB4-9		AUTO-TRANSFORMER CKT #2	37-40
1K9.10		FAN CONTACTORS CKT #1	32-35
1K13.14		FAN CONTACTORS CKT #2	10-12
15.16		INVERTER/AUTO-TRANS PRI FUSES CKT #1	15-17
1F18-20		INVERTER/AUTO-TRANS PRI FUSES CKT #2	720-41
3B2.3.4		FAN MOTORS CKT #1	77.31-53
5.6		FAN MOTORS CKT #2	6
5.6		VARIABLE SPEED FAN MODULE CKT #1	18
5.6		VARIABLE SPEED FAN MODULE CKT #2	42
6RT10		OUTDOOR AIR TEMP SENSOR	46
6RT12		SAT. COND REGT. TEMP SENSOR CKT #1	44
6RT13		SAT. COND REGT. TEMP SENSOR CKT #2	44

AREA	DEVICE FREEX	LOCATION CODE
1		CONTROL PANEL
2		FIRST CKT FANS
3		SECOND CKT FANS
4		UNIT MOUNTED
5		
6		

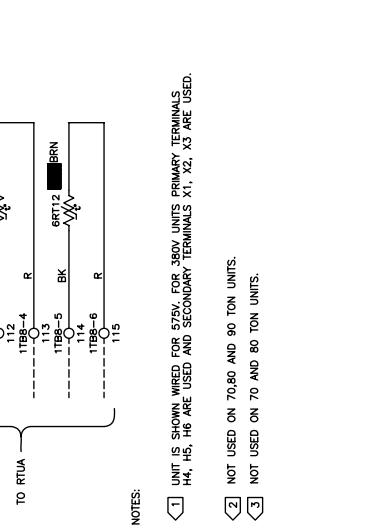
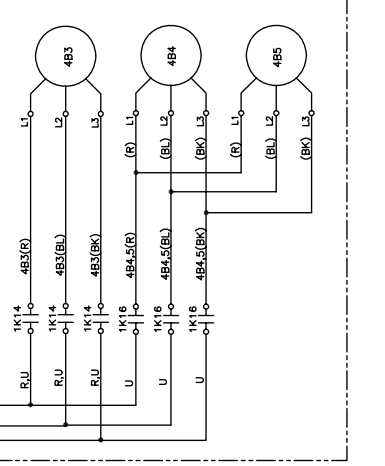

- NOTES:
- 1 UNIT IS SHOWN WIRED FOR 575V. FOR 380V UNITS PRIMARY TERMINALS H4, H5, H6 ARE USED AND SECONDARY TERMINALS X1, X2, X3 ARE USED.
 - 2 NOT USED ON 70, 80 AND 90 TON UNITS.
 - 3 NOT USED ON 70 AND 80 TON UNITS.

CAUTION
USE COPPER CONDUCTORS ONLY!
UNIT TERMINALS ARE NOT DESIGNED TO ACCEPT COPPER CONDUCTORS. FAILURE TO DO SO MAY CAUSE DAMAGE TO THE EQUIPMENT.

ATTENTION
N'UTILISER QUE DES CONDUCTEURS EN CUIVRE!
LES BORNES DE L'UNITÉ NE SONT PAS CONÇUES POUR ACCEPTER DES CONDUCTEURS EN CUIVRE. L'UTILISATION DE TOUT AUTRE CONDUCTEUR PEUT ENDOMMAGER L'EQUIPEMENT.

PRECAUCIÓN
UTILICE ÚNICAMENTE CONDUCTORES DE COBRE!
LAS TERMINALES DE UNIDAD NO ESTÁN DISEÑADAS PARA ACEPTAR CONDUCTORES DE COBRE. EL USO DE OTROS TIPOS DE CONDUCTORES PUEDE DAÑAR AL EQUIPO.

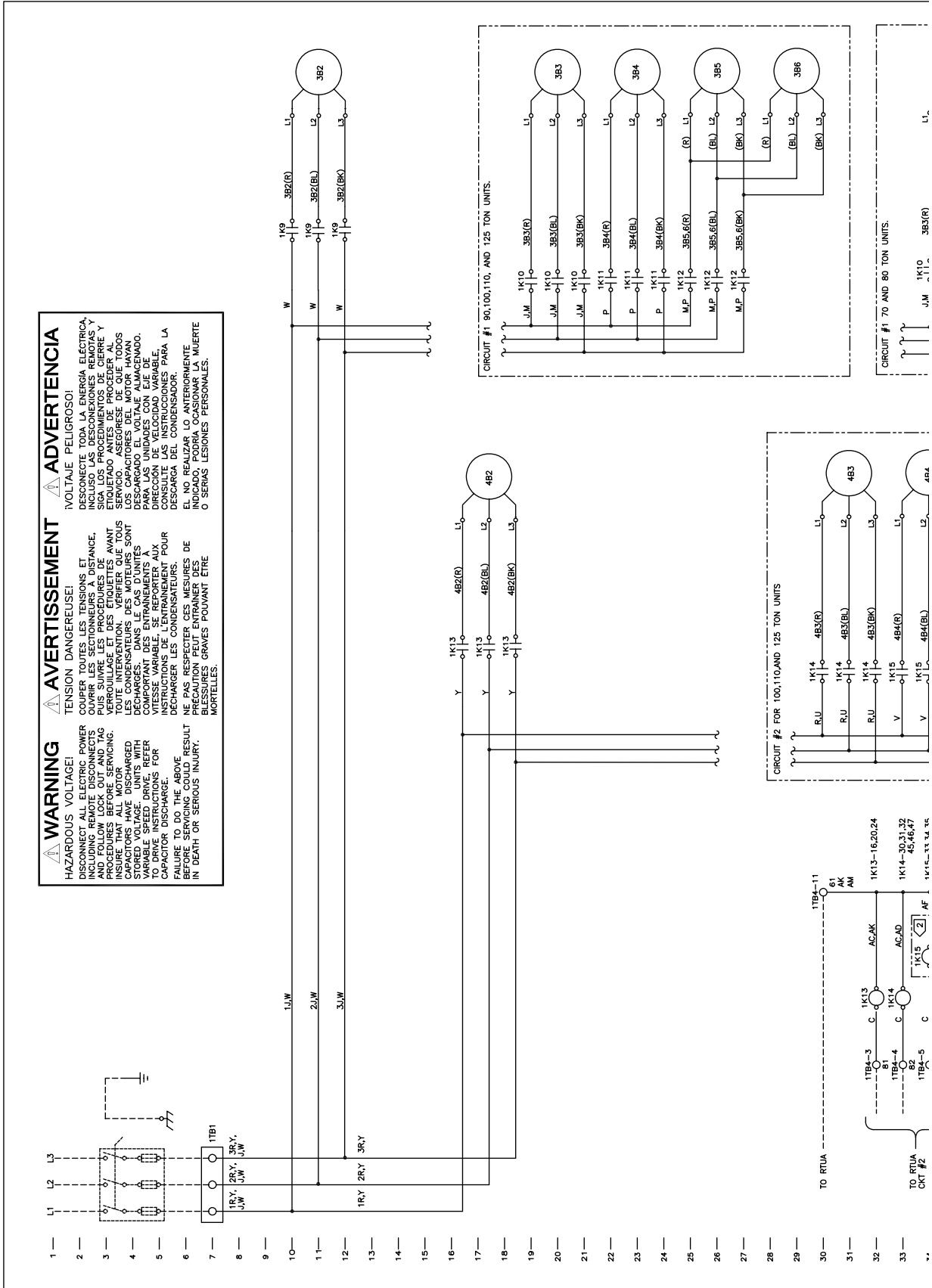

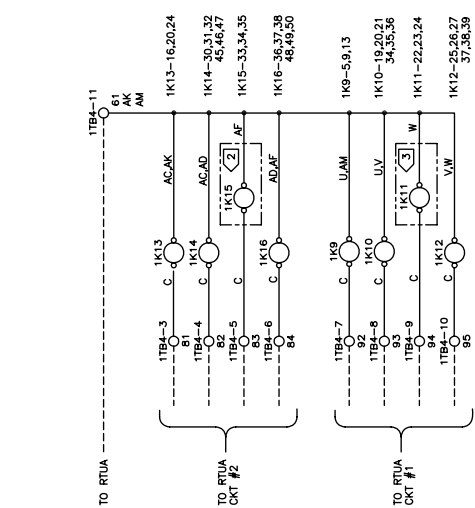
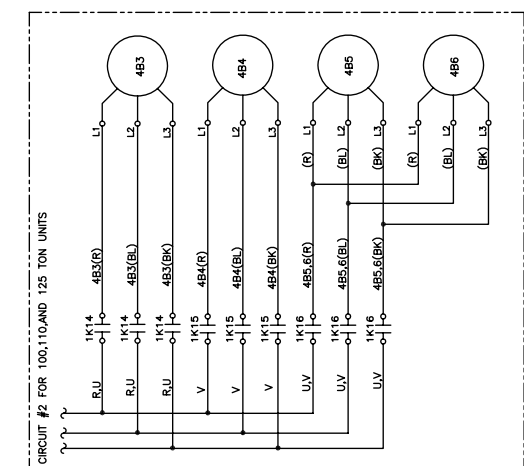
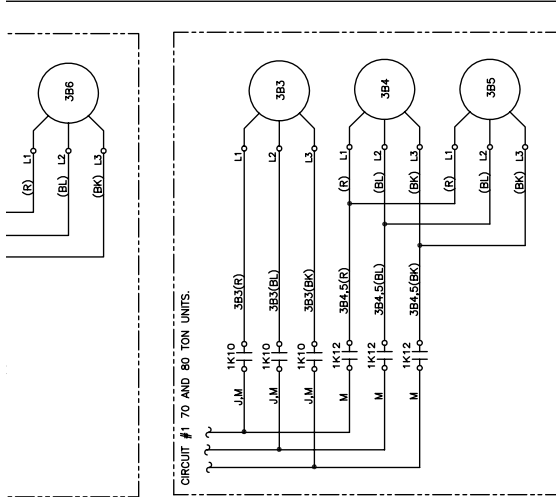

REVISED DATE	8/17/98	PROJECT NO.	2307-6526
DESIGNER	SELENDIA HILL	DRAWN BY	
DATE	8/17/98	SCALE	
THE TRANS COMPANY A DIVISION OF AMERICAN STANDARD INC.		HELICAL ROTOR HERMETIC LIQUID CHILLER SERIES "R" REMOTE AIR COOLED CONDENSER SCHEMATIC WIRING-STANDARD RTCA 70-125 TON	

DEVICE DESIGNATION	LEGEND	LINE NUMBER
1TBA	LINE VOLTAGE TERMINAL BLOCK	7
1TBT	TERMINAL STRIP 115V	
1TB8-9	TERMINAL STRIP 24V	
1T10	AUTO-TRANSFORMER CKT #1	4
1K9,10	FAN CONTACTORS CKT #1	37-40
11,12	FAN CONTACTORS CKT #2	32-35
1K13,14	INVERTER/AUTO-TRANS PRI FUSES CKT #1	10-12
15,16	INVERTER/AUTO-TRANS PRI FUSES CKT #2	15-17
1F18-20	FAN MOTORS CKT #1	11,20-41
1F21-23	FAN MOTORS CKT #2	77,31-53
3B2,3,4	VARIABLE SPEED FAN MODULE CKT #1	6
5,6	VARIABLE SPEED FAN MODULE CKT #2	16
4B2,3,4	OUTDOOR AIR TEMP SENSOR	42
5,6	SAT. COND RFGT. TEMP SENSOR CKT #1	46
6U9	SAT. COND RFGT. TEMP SENSOR CKT #2	44

AREA	DEVICE PREFIX	LOCATION CODE
1		CONTROL PANEL
2		FIRST CKT FANS
3		SECOND CKT FANS
4		UNIT MOUNTED
5		
6		

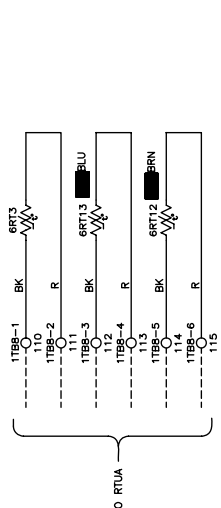
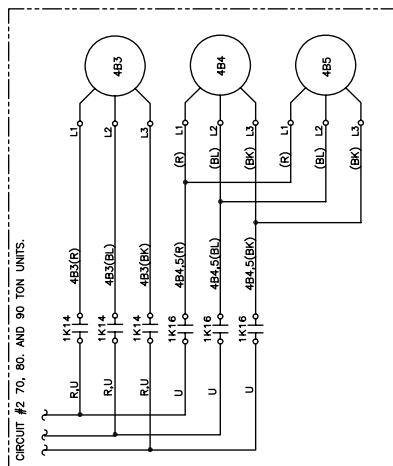

NOTES:
 1 UNIT IS SHOWN WIRED FOR 575V. FOR 380V UNITS PRIMARY TERMINALS H4, H5, H6 ARE USED AND SECONDARY TERMINALS X1, X2, X3 ARE USED.
 2 NOT USED ON 70,80 AND 90 TON UNITS.
 3 NOT USED ON 70 AND 80 TON UNITS.

CAUTION
 USE COPPER CONDUCTORS ONLY!
 OTHER TYPES OF CONDUCTORS MAY FAIL TO DO SO MAY CAUSE DAMAGE TO THE EQUIPMENT.

ATTENTION
 N'UTILISER QUE DES CONDUCTEURS EN CUIVRE!
 D'AUTRES TYPES DE CONDUCTEURS PEUT ENDOMMAGER L'EQUIPEMENT.

PRECAUCION
 UTILICE UNICAMENTE CONDUCTORES DE COBRE!
 OTROS TIPOS DE CONDUCTORES PUEDE OCASIONAR DAÑO AL EQUIPO.

CUSTOMER WIRE SELECTION TABLE				
POWER WIRE SELECTION TO MAIN TERMINAL BLOCK (1TB1)				
UNIT SIZE	UNIT VOLTAGE	TERMINAL BLOCK SIZE	CONNECTOR WIRE RANGE	
70 - 125	200,230 380,400,460,575	175	#14 TO 2/0	
CONTROL WIRE SELECTION FOR 30 VOLT OR LESS CIRCUITS - SEE NOTE 24				
WIRE SIZE	MAXIMUM LENGTH FOR SENSOR LEADS			
14 AWG	5000 FT			
18 AWG	2000 FT			
18 AWG	1000 FT			
FUSE REPLACEMENT SECTION				
FUSE DESCRIPTION	UNIT SIZE	UNIT VOLTAGE	FUSE TYPE	FUSE SIZE
INVERTER/AUTO-TRANSFORMER FUSE (1F18-1F23) (LOW AMBIENT OPTION ONLY)	ALL	575V/460/380/60	CLASS CC (600V)	6 AMP
		380/415/50		
		200/230/60	CLASS CC (600V)	10 AMP

NOTES:

- DASHED LINES INDICATE RECOMMENDED FIELD WIRING BY OTHERS. PHANTOM LINES INDICATE ALTERNATE CIRCUITRY OR AVAILABLE SALES OPTION. CHECK SALES ORDER TO DETERMINE IF WIRING IS REQUIRED FOR SPECIFIC OPTIONS.
- ALL THREE PHASE MOTORS SUPPLIED WITH THE UNIT ARE PROTECTED UNDER PRIMARY SINGLE FAILURE CONDITIONS.
- CAUTION - DO NOT ENERGIZE UNIT UNTIL CHECK OUT AND START-UP PROCEDURES HAVE BEEN COMPLETED.

WIRING AND CONTACT REQUIREMENTS:

- ALL FIELD WIRING MUST BE IN ACCORDANCE WITH THE NATIONAL ELEC CODE (NEC), STATE AND LOCAL REQUIREMENTS, OUTSIDE THE UNITED OTHER COUNTRIES APPLICABLE NATIONAL AND/OR LOCAL REQUIREMENTS APPLY.

11 30 VOLT OR LESS CIRCUIT, DO NOT RUN IN CONDUIT WITH HIGHER CIRCUITS, USE #14-18 AWG, SEE SELECTION TABLE.

12 RECOMMEND USING 3 RUNS OF 2 CONDUCTOR #16 AWG 600V 80 C. SHIELDED WITH DRAIN WIRE (BELDEN 9305 OR EQUIVALENT). DO NOT CONDUIT WITH HIGHER VOLTAGE CIRCUITS.

13 RECOMMEND USING 1 RUN OF 8 CONDUCTOR #22 AWG 300V 80 C. SHIELDED WITH DRAIN WIRE (BELDEN 9305 OR EQUIVALENT). DO NOT CONDUIT WITH HIGHER VOLTAGE CIRCUITS.

WARNING
HAZARDOUS VOLTAGE!
DISCONNECT ALL ELECTRIC POWER INCLUDING REMOTE DISCONNECTS AND FOLLOW LOCK OUT AND TAG PROCEDURES BEFORE SERVICING. INSURE THAT ALL MOTOR CAPACITORS HAVE DISCHARGED STORED VOLTAGE. UNITS WITH VARIABLE SPEED DRIVE, REFER TO DRIVE INSTRUCTIONS FOR CAPACITOR DISCHARGE. FAILURE TO DO THE ABOVE BEFORE SERVICING COULD RESULT IN DEATH OR SERIOUS INJURY.

AVERTISSEMENT
TENSION DANGEREUSE!
COUPER TOUTES LES TENSIONS ET OUVRIR LES SECTIONNEURS A DISTANCE. PUIS SUIVRE LES PROCEDURES DE VERROUILLAGE ET DES ETIQUETTES AVANT TOUTE INTERVENTION. VERIFIER QUE TOUS LES CONDENSATEURS DES MOTEURS SONT DECHARGES. DANS LE CAS D'UNITES COMPORTANT DES ENTRAINEMENTS A VITESSE VARIABLE, SE REPORTER AUX INSTRUCTIONS DE L'ENTRAINEMENT POUR DECHARGER LES CONDENSATEURS. NE PAS RESPECTER CES MESURES DE PRECAUTION PEUT ENTRAENER DES BLESSURES GRAVES POUVANT ETRE MORTELLES.

ADVERTENCIA
¡VOLTAJE PELIGROSO!
DESCONECTE TODA LA ENERGIA ELÉCTRICA, INCLUSO LAS DESCONEJONES REMOTAS Y SIGA LOS PROCEDIMIENTOS DE CIERRE Y ETIQUETADO ANTES DE PROCEDER AL SERVICIO. ASEGÚRESE DE QUE TODOS LOS CAPACITORES DEL MOTOR HAYAN DESCARGADO EL VOLTAJE ALMACENADO. PARA LAS UNIDADES CON EJE DE DIRECCIÓN DE VELOCIDAD VARIABLE, CONSULTE LAS INSTRUCCIONES PARA LA DESCARGA DEL CONDENSADOR. EL NO REALIZAR LO ANTERIORMENTE INDICADO, PODRÍA OCASIONAR LA MUERTE O SERIAS LESIONES PERSONALES.

CAUTION
USE COPPER CONDUCTORS ONLY!
UNIT TERMINALS ARE NOT DESIGNED TO ACCEPT OTHER TYPES OF CONDUCTORS. FAILURE TO DO SO MAY CAUSE DAMAGE TO THE EQUIPMENT.

ATTENTION
N'UTILISER QUE DES CONDUCTEURS EN CUIVRE!
LES BORNES DE L'UNITÉ NE SONT PAS CONÇUES POUR RECEVOIR D'AUTRES TIPOUS DE CONDUCTEURS. L'UTILISATION DE TOUT AUTRE CONDUCTEUR PEUT ENDOMMAGER L'EQUIPEMENT.

PRECAUCIÓN
¡UTILICE ÚNICAMENTE CONDUCTORES DE COBRE!
LAS TERMINALES DE LA UNIDAD NO ESTÁN DISEÑADAS PARA ACEPTAR OTROS TIPOUS DE CONDUCTORES. SI NO LO HACE, PUEDE OCASIONAR DAÑO AL EQUIPO.

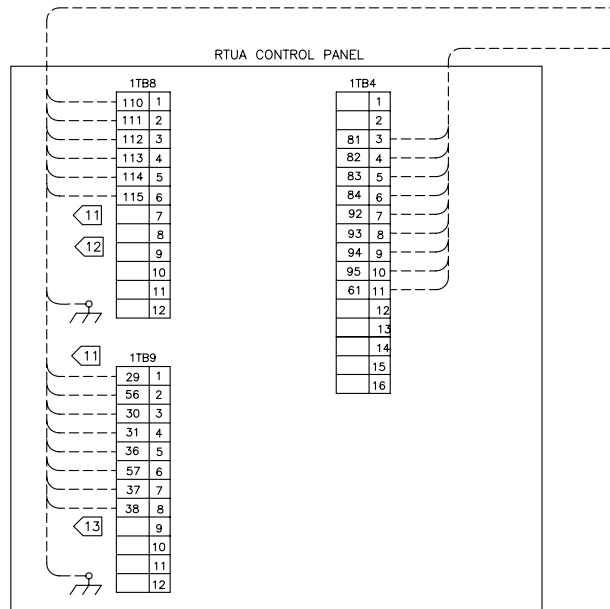

INDICATE RECOMMENDED FIELD WIRING BY
 TOM LINES INDICATE ALTERNATE CIRCUITRY OR
 IS OPTION. CHECK SALES ORDER TO DETERMINE
 EQUIPED FOR SPECIFIC OPTIONS.

USE MOTORS SUPPLIED WITH THE UNIT ARE
 DER PRIMARY SINGLE FAILURE CONDITIONS.

NOT ENERGIZE UNIT UNTIL CHECK OUT AND START-UP
 HAVE BEEN COMPLETED.

CONTACT REQUIREMENTS:

WIRING MUST BE IN ACCORDANCE WITH THE NATIONAL ELECTRICAL
 STATE AND LOCAL REQUIREMENTS, OUTSIDE THE UNITED STATES,
 REQUIRES APPLICABLE NATIONAL AND/OR LOCAL REQUIREMENTS SHALL

LESS CIRCUIT, DO NOT RUN IN CONDUCT WITH HIGHER VOLTAGE
 #14-18 AWG, SEE SELECTION TABLE.

USING 3 RUNS OF 2 CONDUCTOR #16 AWG 600V 80 C. 100%
 1 DRAIN WIRE (BELDEN 9305 OR EQUIVALENT). DO NOT RUN IN
 HIGHER VOLTAGE CIRCUITS.

USING 1 RUN OF 8 CONDUCTOR #22 AWG 300V 80 C. 100%
 1 DRAIN WIRE (BELDEN 9305 OR EQUIVALENT). DO NOT RUN IN
 HIGHER VOLTAGE CIRCUITS.

REPLACES	2D CAD	FILE NUMBER	DRAWING NUMBER	REV.
REVISION DATE	THE TRANE COMPANY		2307-5150	F
11-12-96	A DIVISION OF AMERICAN STANDARD INC.	HELICAL ROTOR HERMETIC LIQUID CHILLER		
DRAWN BY		SERIES "R"		
AM		REMOTE AIR COOLED CONDENSER		
DATE	SIMILAR TO	FIELD WIRING		
3-29-94		RTCA 70-125 TON		

RTCA CONTROL PANEL

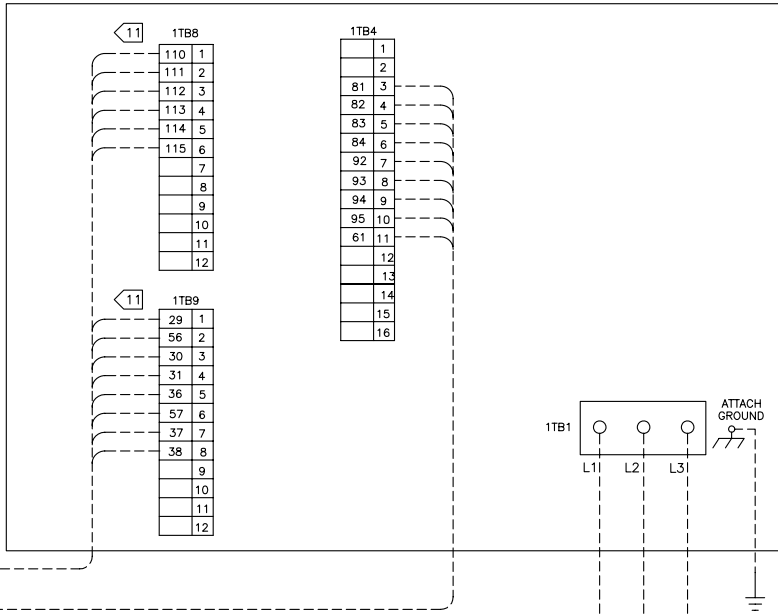

CONTROL PANEL

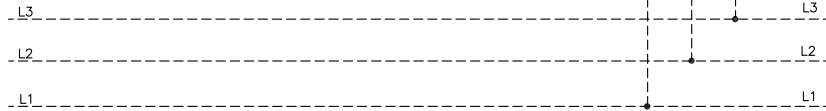
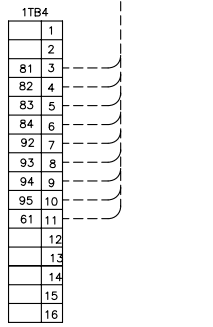

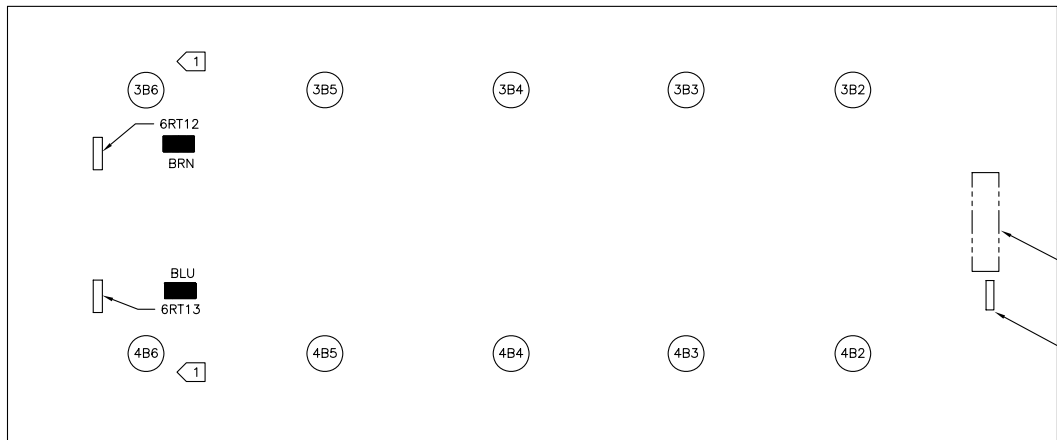
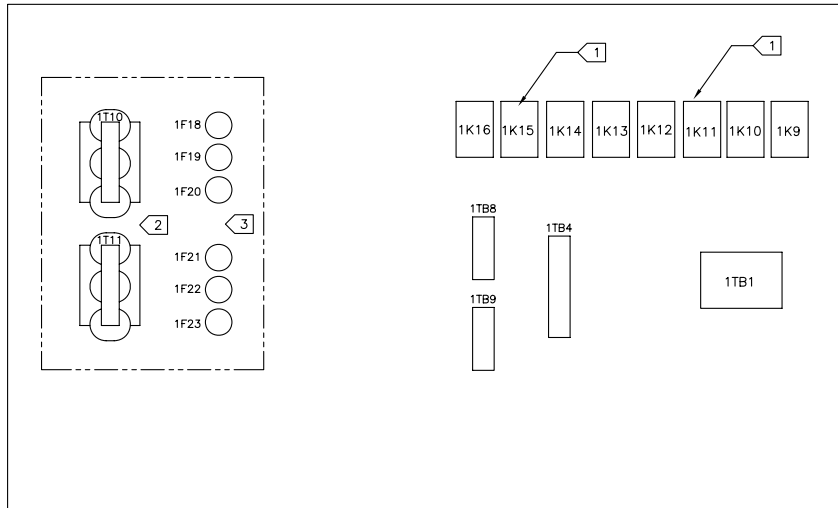

RTCA 100-125 SHOWN
 RTCA 70-90 SIMILAR (EXCEPT AS NOTED)

REPLACES	2D C AD	FILE NUMBER	DRAWING NUMBER	REV
REVISION DATE	THE TRANE COMPANY A DIVISION OF AMERICAN STANDARD INC.		2307-6010	C
DRAWN BY	<small>THIS DRAWING IS PROPRIETARY AND COPYING, REUSE OR DISTRIBUTION WITHOUT THE WRITTEN CONSENT OF THE TRANE COMPANY</small>	HELICAL ROTOR HERMETIC LIQUID CHILLER RTCA 70-125 TON COMPONENT LOCATION		
DATE	SIMILAR TO			
8/17/98				

- ① CONTACTORS 1K11 AND 1K15 AND FANS 3B6 AND 4B6 ARE NOT USED ON 70 AND 80 TON UNITS. CONTACTOR 1K15 AND FAN 4B6 ARE NOT USED ON 90 TON UNITS.
- ② TRANSFORMER 1T10 AND 1T11 USED ONLY ON LOW AMBIENT 380 AND 575V 60HZ. FUSES 1F18-1F23 USED ONLY ON LOW AMBIENT UNITS.
- ③ LOW AMBIENT OPTION ONLY.

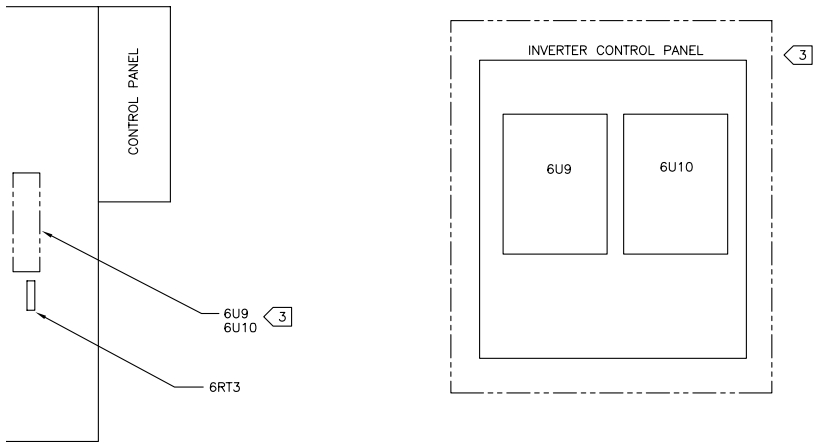



Trane
A business of American Standard Companies
www.trane.com

For more information contact your local district office or e-mail us at comfort@trane.com

Literature Order Number	RLC-SVX07A-EN
File Number	SV-RF-RLC-SVX07A-EN-1005
Supersedes	RTWA-IOM-1A
Stocking Location	Inland

Trane has a policy of continuous product data and product improvement and reserves the right to change design and specifications without notice. Only qualified technicians should perform the installation and servicing of equipment referred to in this bulletin.