



TEMPERATURE CONTROLLERS... PORTABLE CHILLERS... CENTRAL CHILLERS... PUMP TANK STATIONS... TOWER SYSTEMS...

SUBJECT: STANDARD VS REVERSE FLOW CHILLERS

#3-A-011 12/07/00

**OVERVIEW:**

Determining the correct style of chiller flow circuit is just as important as matching chilling capacity to a given process. The following explains the major differences.

**ADVANTAGE** standard flow chillers are intended to be used on closed loop processes, such as molds, dies, rolls, coils, etc. Water returning to the chiller is dependent on flow generated initially by the chiller process pump. If the loop is open to the atmosphere at any point, such as an extrusion trough, overflow will always result.

**ADVANTAGE** reverse flow chillers are designed specifically for open circuit processes. Notice that the flow circuit remains basically the same, but the process acts as the chiller reservoir, and gravity returns water to the pump suction. System water make-up and level control is accomplished externally at the process since the chiller contains no reservoir.

When ordering a reverse flow chiller, please specify the suffix "R" after the model number. EXAMPLE: MX-10AR

**STANDARD FLOW CHILLER**

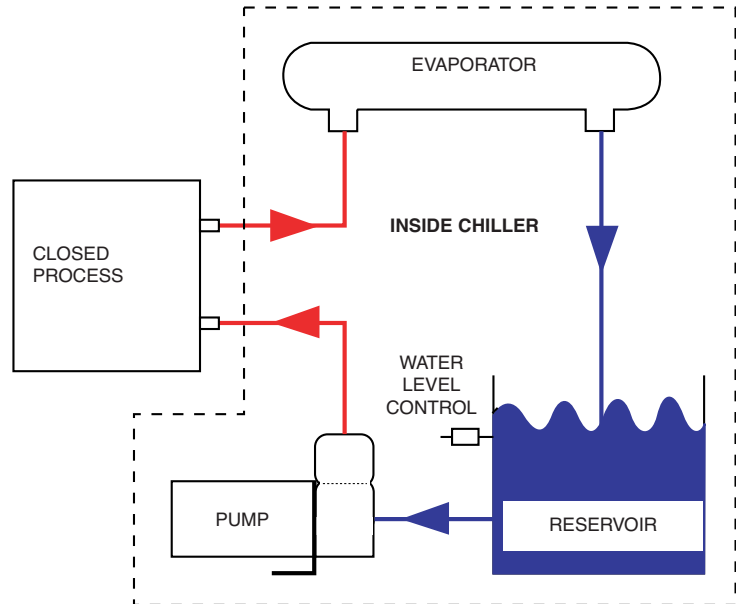

**REVERSE FLOW CHILLER**

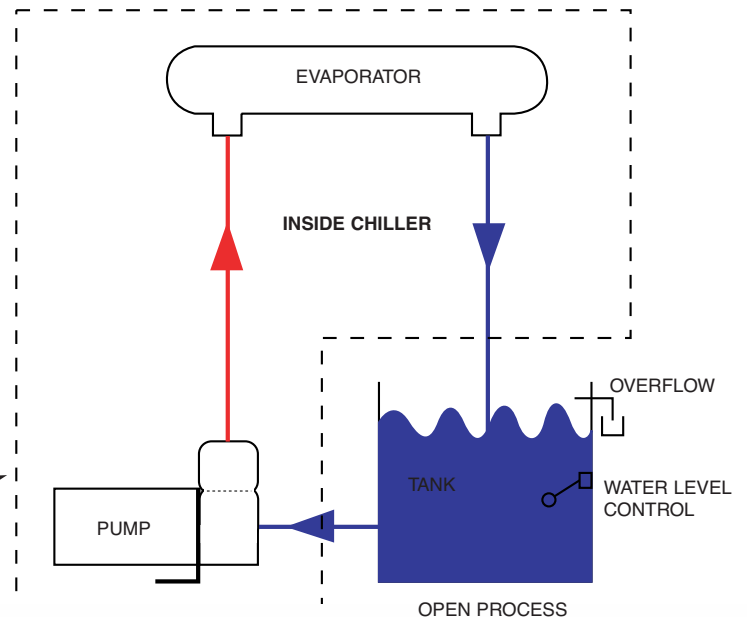

Note - items shown within the dotted borders represent components located inside the chiller.