

OPERATING MANUAL

PC 160.01-NZ-DIS



Glen Dimplex Deutschland GmbH
Devision RIEDEL Cooling
Am Goldenen Feld 18
D-95326 Kulmbach

Phone: +49 (0) 92 21 / 709 555
Fax: +49 (0) 92 21 / 709 549

e-mail: info@Riedel-Cooling.com
<http://www.Riedel-Cooling.com>

HEADQUARTER GERMANY

Telefon: +49 (0) 92 21 / 709 545
Telefax: +49 (0) 92 21 / 709 529

e-mail: service@Riedel-Cooling.com
<http://www.Riedel-Cooling.com>

PARTS & SERVICE HOTLINE

NORTH AMERICA

Telephone-No: ++1-(734) 595 9820
Telefax-No: ++1-(734) 595 9829
Toll-free-No: ++1-(877) RIEDEL1
++1-(877) 743 3351

e-mail: service@riedel-usa.com
<http://www.riedel-usa.com>

This document was drawn up by the **Technical Documentation** department of Glen Dimplex Deutschland GmbH.

Glen Dimplex Deutschland GmbH reserves all rights to this documentation, especially the right to reproduce, distribute and translate this document. This also applies in case of patent and industrial rights.

No part of this document may be reproduced, processed, copied or distributed by either conventional or electronic means without the prior written consent of Glen Dimplex Deutschland GmbH.

Subject to errors and technical changes.

Glen Dimplex Deutschland GmbH assumes no responsibility for any errors in this documentation. To the extent permissible by law, Glen Dimplex Deutschland GmbH will not be liable for any claims for direct or indirect damages arising in connection with the supply or non-use of this documentation.

Vom Anwender einzutragen :

To be entered by the user :

Inventarnummer:
Inventory number:

Aufstellungsort:
Installation site:

Ausgabe
Edition **04/2012**

Table of Contents

1.	For Your Safety	6
1.1	Regulations	6
1.2	Signs and Symbols	7
1.3	Safety Notices	8
1.4	Handling of Refrigerants	9
1.5	Safety Requirements	9
1.5.1	Installation	9
1.5.2	Operation	10
1.5.3	Requalification Tests	10
1.6	Purpose of the Process Cooler	10
2.	Description of the Process Cooler	11
2.1	Refrigeration Circuit	11
2.2	Water Circuits	12
2.2.1	DI Circuit	12
2.2.2	Laser Circuit	12
2.3	Cooling Air Supply	12
2.4	Safety Devices	13
2.5	Monitoring Devices	13
2.6	Electrical / Control Equipment	15
3.	Technical Data	16
4.	Transport and Storage	17
4.1	Transport Specification	17
4.2	Transport Using a Forklift	17
4.3	Transport Using a Lift Truck	18
4.4	Transport Using a Crane	19
4.5	Storage of the Process Cooler	19
5.	Installation	20
5.1	Indoor Installation	20
5.2	Outdoor Installation	21
6.	Assembly	22
6.1	Connection of Water Piping	22
6.2	Electro-Technical Connection	22
7.	Commissioning	23
7.1	Laser Circuit	23
7.2	DI Circuit	24
7.3	Bleeding Air from Pumps	25
7.4	Hydraulic Settings Upon Frequency Change	26
7.5	Refrigeration Circuit	30
8.	Decommissioning	30
9.	Shutdown in Emergencies	30
10.	Environmental Requirements	30

11. Operation of Control and Operating Unit	31
12. Maintenance	32
12.1 Cleaning After-Filter of the Ion Filter	33
12.2 Replacement of Ion Filter	34
13. Requalification Tests	36
14. Malfunctions / Troubleshooting	38
Appendix	40
Dimensions PC 160.01-NZ-DIS	
PI Flow Diagram PC 160.01-NZ-DIS	
Spare Parts List	
Pump Characteristics	
Sample System Log	
Sample Quick Reference Guide	
Wiring Diagrams	
Parameter Lists	

1. FOR YOUR SAFETY

1.1 Regulations

Design, construction and development of the process cooler are in compliance with the following national and international regulations.

EC Directives / Standards

- EC-EMC-Directive: 2004/108/EC
- EC-Pressure equipment directive: 97/23/EC
- EC-Directive for machines: 2006/42/EC

- EN 378 -1, -2, -3, -4 Refrigeration plants and heat pumps

- EN 60529 Degrees of protection provided by enclosures (IP)

- EN ISO 12100-1, -2 Safety of machinery

- EN ISO 13857 Safety of machinery

- EN 349 Safety of machinery

- EN 60204-1 Electrical equipment of machinery

- EN 61000-6-2 Electromagnetic compatibility -
Generic immunity standard for industrial environments

- EN 61000-6-4 Electromagnetic compatibility -
Generic emission standard for industrial environments

National Directives

- BGR 500 Accident prevention regulations concerning refrigeration at pumps

1.2 Signs and Symbols

Throughout this operating manual, the notices below are identified by the following graphical symbols (pictographs):

Pictographs



Danger!

Safety note pointing out an imminent danger. Failure to heed the warning may result in serious bodily injury and even death.



Caution!

Safety note to indicate the presence of a potential hazard. Failure to heed the safety notice may result in minor bodily injury or damage to the equipment.



Information!

This symbol identifies important information or a useful tip concerning the application of the equipment.

1.3 Safety Notices

For the installation, operation and maintenance of the process cooler, the following regulations and safety notices must be observed:



Any work on the process cooler may only be performed by qualified personnel

All relevant accident prevention regulations must be observed

Do not allow anybody to stand or pass underneath the forks when lifting and setting down the process cooler; stay clear of the danger area.

The process cooler must be properly secured in order to prevent it from tipping over

The safety devices must not be deactivated

The electro-technical connections of the process cooler must be performed according to and conforming with all relevant VDE, EN and IEC standards. Beyond that, the technical connection requirements of the local electrical utility company must be observed

Do not attempt to perform any work on the process cooler unless the unit is disconnected from the power supply



National provisions applicable in the country where the unit will be installed must be adhered to

The closed refrigeration circuit contains the refrigerant and refrigeration oil. These must be properly disposed of when performing service work or placing the unit out of service (environment)

The cooling water additives have a caustic effect on skin and eyes. When working with cooling water additives, eye protection devices and gloves must be worn. Follow the directions on the product's label.

Anyone working on the refrigeration circuit must be protected by personal protective equipment.

The process cooler is to be used exclusively for the cooling of water (drinking water) and de-ionised water in accordance with predefined IPG specifications.



Watch out for any incompatibilities of materials in the entire water circuit.

The water must be free of all substances that could result in mineral deposits and corrosion!

The water used in the cooling circuit must comply, at a minimum, with the values specified by the Ordinance on Drinking Water. In the case of de-ionised water, additional constructional features are necessary.

Recommended limit values:

	<u>Drinking water</u>	<u>DI water</u>
- Electric conductivity at 25 °C:	80 - 750 µS/cm	20 µS/cm
- Hydrogen concentration at 20 °C:	6.5 ... 9.5 (pH value)	6.0 ... 7.5 (pH value)
- Chloride:	< 250 mg/l	< 1 mg/l
- Total hardness:	min. 6 °dH	< 0.005 °dH
- Appearance:	clear, no sediments	clear, no sediments
- Colour:	transparent	transparent
- Total colony count at 22°C:	< 100 KBE s/ml	

1.4 Handling of Refrigerants



When handling refrigerants, all legal provisions and guidelines must be complied with. Only qualified personnel may perform these activities.

The operator of the process cooler is responsible for the proper disposal of used refrigerants and system parts.

1.5 Safety Requirements

concerning the operation of refrigeration systems within the European Union

The following information applies to refrigeration systems with closed refrigeration cycles that are used within the European Union. In some member states additional requirements may apply, e.g. due to environmental considerations.

In the refrigeration units described in this operating manual, working pressures occur that are subject to the regulations laid down in the Pressure Vessel Directive 97/23/EC and European standard EN 378 (Parts 1 – 4, version September 2000).



Apart from the requirements relating to the design, equipment and testing of the refrigeration systems prior to delivery to the customer, also the operator of such systems has to comply with requirements in accordance with European standard EN 378 and/or additional national regulations. These concern the **installation**, the **operation** and **requalification tests** of refrigeration systems.

1.5.1 Installation

If the process cooler is installed below ground level or on upper floors of a building, without any adequate number of emergency exits, requirements relating to the protection of people in accordance with EN 378 have to be complied with.

With respect to the actual refrigerant charge of the process cooler, a minimum room volume must be maintained and not be fallen short of.

Refrigerant	R407C
PC 160	19 m ³
PC 250	29 m ³
PC 400	56 m ³

Minimum room sizes in [m3] are required for the installation of refrigeration units, depending on the refrigerant being used.

It can thus be ensured that in the case of refrigerant leaks caused by damage to the equipment – and thus the displacement of oxygen – will not have any detrimental effect on the health of people.

1.5.2 Operation



The owner or the operator of the process cooler is obligated to establish emergency practices (in the case of accidents and malfunctions.). A short version of the operating instructions must be drawn up by the operator – based on this present Operating Manual – and made known to the employees.

The quick reference guide must be clearly legible and affixed in the immediate vicinity of the process cooler.

See Sample Quick Reference Guide



The owner or operator of a system is obligated to keep a logbook for the process cooler.

The system logbook must either be available on site near the process cooler, or in the event that the data are stored in a computer of the owner or operator, a printout of the log must be kept in the vicinity of the process cooler. It must be ensured that these data are accessible to qualified persons for the performance of repairs and requalification tests.

See Sample System Log

1.5.3 Requalification Tests

To ensure compliance with minimum safety and health requirements as set forth in standard EN 378, regular testing (requalification testing) of the process coolers is to be carried out by competent persons.



The operator is responsible for the performance of the retests.

(See Chapter Requalification Tests).

1.6 Purpose of the Process Cooler

The process cooler described in this manual is designed exclusively for the cooling of water (drinking water) and de-ionised water within the specified operating temperature limits.

2. DESCRIPTION OF THE PROCESS COOLER

The process cooler is a unit ready for plug-in and is equipped with refrigeration and water circuits including all fittings and regulating/control devices required for automatic operation. The heat extracted from the water is given off to the ambient air via the refrigeration circuit – by means of the fans.

2.1 Refrigeration Circuit

The refrigeration circuit is a closed-loop system in which the refrigerant circulates as the working medium.

The water heated by the equipment to be cooled is re-cooled in the evaporator (4). The liquid refrigerant is thereby passed through the piping in a counter-flow arrangement with respect to the water. The refrigerant evaporates as it takes up the waste heat from the cooling water of the equipment to be cooled.

The vaporised refrigerant is drawn in by the compressor (1) and is then compressed (rise in pressure and temperature). The refrigerant also absorbs the heat of the compressor motor; this heat is given off to the surrounding air by the condensers (2) - in the form of waste heat – by means of the fan (3).

The refrigerant is thus liquefied and is passed to the inlet of the expansion valve (5) via the liquid receiver, the shut-off valve, the filter drier and the sight glass. The expansion valve permits liquid refrigerant to enter the evaporator as a function of the temperature.

The circuit is now complete.

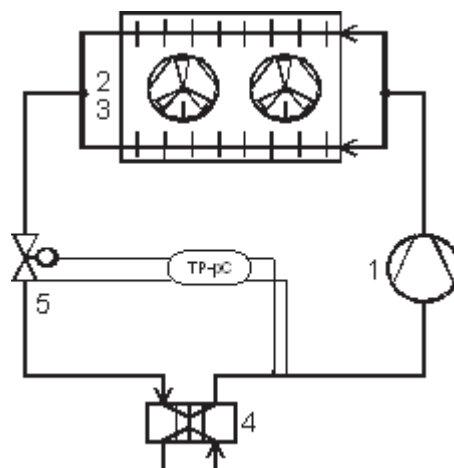

Block flow diagram, refrigeration circuit

2.2 Water Circuits

Each of the water circuits with their built-in tanks are designed as systems open to the atmosphere.

2.2.1 DI Circuit

The DI circuit is cooled by the laser circuit via a plate heat exchanger. The water outlet temperature of the DI circuit is therefore higher than the water outlet temperature of the laser circuit.

The temperature of the water outlet temperature is maintained at a constant level by the water volume inside the tank. The pump conveys the water out of the tank to the optics circuit and in parallel to the plate heat exchanger of the laser circuit and back to the tank.

In a bypass circuit, the pump conveys DI water through the ion filter, strainer and then back to the tank. The ion filter filters ions from the DI water. The conductivity of the DI water can thus be maintained within the permissible range of $< 20 \mu\text{S}$ for an extended period of time. When the ion filter has been used up it must be replaced.

2.2.2 Laser Circuit

The temperature of the water outlet temperature is maintained at a constant level by the water volume inside the tank. The pump conveys the water out of the tank to the laser and in parallel to the plate heat exchanger of the laser circuit and back to the tank.

2.3 Cooling Air Supply

The heat transferred to the evaporator upon cooling the water as well as the heat of the compressor motors are absorbed by the refrigerant and given off to the cooling air, in the condenser.

The ambient air is used as cooling air, which is drawn through the condenser by the fan(s), warmed in the process and discharged in upward direction.



**It must be ensured that the cooling air can be drawn in and discharged without any obstructions and adequate air changes for heat dissipation away from the installation site of the process cooler take place.
(see also Section Installation)**

2.4 Safety Devices

The process cooler is equipped with the following safety devices:

High-pressure control (HP)

The high-pressure control is designed to protect the process cooler against extremely high operating pressure in the refrigeration cycle.

In the event of a malfunction, the HP control switches the process cooler off, and the malfunction is indicated on the control panel.

The process cooler cannot be restarted until the pressure has dropped to the preset pressure difference and the Reset button on the pressostat has been pressed. The high-pressure pressostat can be accessed from the service side.



Power disconnect switch (main switch)

In an emergency, the process cooler must be switched off by means of the main switch.

2.5 Monitoring Devices

Low-pressure control (LP)

The low-pressure control protects the process cooler against extremely low operating pressure in the refrigeration cycle.

In the event of a malfunction, the control switches off the process cooler, and the malfunction is indicated on the control panel.

Restarting of the process cooler is effected automatically as soon as the pressure has risen by the preset pressure difference.

Winter starting aid

The winter starting aid is designed to prevent any low pressure malfunctions in low ambient temperatures during the start-up phase of the cooling operation until normal operating conditions have been established.

Compressor overheat protection

The compressor is equipped with an overheat protection (thermal contact, Klixon). In the event of an increase in motor current in conjunction with a rise in winding temperature, the overheat protection trips, and the compressor is switched off. The overheat protection resets itself automatically after the windings have cooled down. The malfunction is indicated on the control panel.

Thermal contact - fan motor

In the event of an increase in motor current in conjunction with an increase in winding temperature, cooling operation is switched off by the thermal contact.

This malfunction is indicated on the control panel.

Circuit breakers (compressor, fan, pump)

In the event of an increase in motor current or in the case of short circuits, the circuit breaker trips and interrupts the power supply.

Such malfunctions are indicated on the control panel. The circuit breakers are located in the control cabinet.

Float switch

The float switch monitors the water level in the tank.

Maintaining the minimum water level ensures that the water outlet temperature remains constant.

In the event of a water shortage, the pump/s is/are switched off (dry run protection). These malfunctions are displayed on the control panel.

The float switch is located inside the tank.

Fan control

The condensation pressure is controlled by cycling the individual fans on and off.

This type of control permits an adaptation to different operating conditions at relatively constant condensation temperatures.

Control and operating unit

The control and operating unit controls the water circuits and the refrigeration cycle.. The control and operating unit including the control panel with display of the water temperatures, as well as the error codes in the case of a common fault alarm, is integrated in the control cabinet door.

Pressure gauge

The pressure gauge indicates the pressure at the water inlet and outlet.

Overflow valve

The overflow valve ensures the minimum flow rate in the water circuit. The evaporator and pump in the single-circuit system are thus protected.

Fixed bypass in the DI circuit

The fixed bypass consists of strainer, DI cartridge and shut-off valve.

Strainer

If there is a danger of contamination of the water by particulates with a diameter > 1 mm, a filter with a suitable mesh size must be used. The strainer has to be mounted outside the process cooler, the proper flow direction must be observed.

After commissioning, the strainer must be cleaned on a regular basis. The strainer must be fitted on the outside of the water inlet.

Digital thermometer

The thermometer senses the water inlet or outlet temperature, the readout is displayed on the control panel of the control and operating unit.

Temperature limit values

The water temperatures in the water circuit are monitored by limit values. If the preset limit values are exceeded or not reached, a common fault alarm is triggered via the control and operating unit.

Tank heater as freeze protection measure

The tank heater is designed to warm the water inside the tank. In low ambient temperatures and in the absence of any process heat (e.g. plant shutdown) the water is thus protected against freezing.

If there is a danger of frost, the circulating pump is switched on via a thermostat. The electric heater is controlled by a thermostat fitted with sensor in the water circuit.

Control cabinet heater

The control cabinet heater is installed for temperature stabilisation of the control cabinet inside temperature versus the ambient temperature (condensation water formation) and for ensuring minimum temperatures for the switchgear and controlgear inside the control cabinet.

Conductivity control - DI circuit

The conductivity sensor integrated in the control and operating unit for the process coolers monitors the conductivity value of the water circuit. In case the preset conductivity value is exceeded, a common fault alarm is released and displayed on the control panel via the appropriate error code.

24 V remote control

The process cooler is switched ON and OFF via a 24 V remote control unit. The 24 V signal is to be connected in accordance with the circuit diagram.

Condenser guard with filter mat

The condenser guard protects the condenser against mechanical damage. The filter mat protects the condenser and the process cooler against contamination.

2.6 Electrical / Control Equipment

The electro-technical equipment of the process cooler is installed in the control cabinet. All required components for the automatic switching, controlling and regulating operation are contained in the control cabinet.

The main electric circuits are of a non-fused design featuring motor protecting switches. The connection of the process cooler to the equipment to be cooled is effected via a potential-free interface.

The interface transmits the following signals:

- „Malfunction” Continuous signal from the process cooler to the equipment to be cooled.

The water outlet temperature is kept constant by the control and operating unit at a given setpoint value by activation of power stages in the refrigeration cycle. The current water outlet temperature is displayed on the control panel.

3. TECHNICAL DATA

Technical Data							
Designation		PC 160.01-NZ-DIS		PC 250.01-NZ-DIS		PC 400.01-NZ-DIS	
General Data		50 Hz	60 Hz	50 Hz	60 Hz	50 Hz	60 Hz
IPG laser type	YLR	5000		10000		15000	
Net refrigeration capacity	kW	20,0 kW	21.5 kW	38,0 kW	40.3	54,0 kW	60,0 kW
Refrigerant	A	R407C		R407C		R407C	
Required cooling air volumetric flow rate		8700		16400		26100	
Installation		Option: outdoor installation		Option: outdoor installation		Option: outdoor installation	
No. of compressors		2		2		2	
No. of fans		1		2		3	
No. of pumps		2		2		2	
Operating Limits							
Design operating temperature	°C	33		33		33	
Min. operating temperature	°C	-20		-20		-20	
Max. operating temperature	°C	44	41	43	40	43	39
Storage temperature min. (w ater circuit drained)	°C	-40		-40		-40	
Storage temperature max.	°C	60		60		60	
Cold w ater tank capacity	litres	140		75		240	
Electrical Data							
Power consumption at operating point w/o heater	kW	11,0 kW	13.2 kW	17.0 kW	20.4 kW	23.5 kW	29.0 kW
Power consumption at operating point w ith heater	kW	15	17.2	20,5 kW	24,4 kW	28,0 kW	33,5 kW
Max. power consumption	kW	19,5		27		34	41
Max. current draw	A	30		42		60,5	
Max. back-up fuse	A	35		50		80	
Start-up current	A	53		92,5		141	
Supply voltage		400 V / 3 Ph / PE	460 V / 3 Ph / PE	400 V / 3 Ph / PE	460 V / 3 Ph / PE	400 V / 3 Ph / PE	460 V / 3 Ph / PE
Tolerance of supply voltage		+/- 10 %		+/- 10 %		+/- 10 %	
Dimensions, Weights and Sound Level							
Weight w ithout w ater charge	kg	350		500		900	
Sound pressure level at 5 m distance	db(A)	61		64		68	
Width	mm	1440		1440		2120	
Depth	mm	860		860		860	
Height	mm	1697		1697		1977	
Normal Water Circuit							
Cooling capacity	kW	16,0 kW	17,5 kW	34,0 kW	36,3 kW	50,0 kW	60,0 kW
Cold w ater outlet temperature	°C	21		21		21	
Cold w ater return temperature	°C	26		26		26	
Setpoint tolerance	K	1		1,2		1	
Amount of cold w ater vs. free pump pressure		69 l/min at 1.5 bar		90 l/min at 1.5 bar		136 l/min at 1.5 bar	
Amount of cold w ater vs. free pump pressure		46 l/min at 4.0 bar		60 l/min at 3,0 bar		90 l/min at 3,0 bar	
DI Water Circuit							
Cooling capacity	kW	4,0 kW		4,0 kW		4,0 kW	
Cold w ater outlet temperature	°C	26		26		26	
Cold w ater return temperature	°C	31		31		31	
Setpoint tolerance	K	1		1		1	
Amount of cold w ater vs. free pump pressure		20 l/min at 1.5 bar		20 l/min at 1.5 bar		20 l/min at 1.5 bar	
Amount of cold w ater vs. free pump pressure		15 l/min at 4.0 bar		15 l/min at 4.0 bar		15 l/min at 4.0 bar	

4. TRANSPORT AND STORAGE



The safety notices contained in Chapter 1 must be complied with!

As a rule, the process cooler must be transported in upright position without water charge!

The in-house transport is carried out by a forklift, lift truck or crane. This process cooler must be deposited on a level surface in order to prevent any distortion of the base-frame.

4.1 Transport Specification

- Weights	PC 160	PC 250	PC 400
Weight without tank charge	350	500	900
Weight with tank charge	515	600	1165

- Main dimensions (see Chapter Technical Data)
- Ambient temperatures -40°C to $+60^{\circ}\text{C}$



In ambient temperatures $<0^{\circ}\text{C}$ the water circuits must be completely drained, including pumps, water filters and tanks.

(See Chapter Decommissioning)

4.2 Transport Using a Forklift

To transport the process cooler with a forklift, the recesses provided at the broadside of the base-frame of the unit should exclusively be used. Do not lift the unit until the forks have been inserted horizontally all the way beneath the unit, symmetrically to the centre of gravity of the process cooler.



The lifting rate should be kept to a minimum!

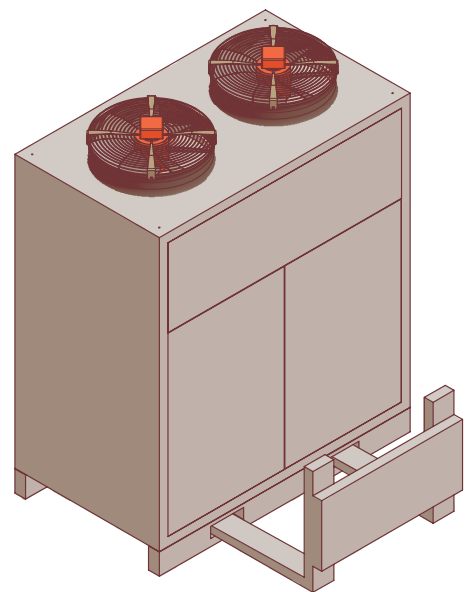
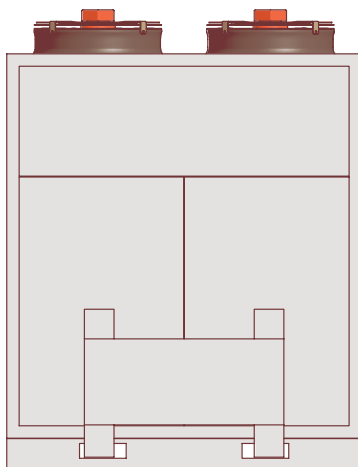

Schematic:
Transport using a forklift

4.3 Transport Using a Lift Truck

Handling the unit from the narrow side:

The process cooler can be transported by means of two lift trucks with the forks being inserted under the load from the narrow sides.

To ensure that the forks can be inserted under both cross beams, a minimum fork length must be maintained.

Both lift trucks must be actuated at the same time in order to prevent the process cooler from becoming off-centred.



The lifting rate should be kept to a minimum!

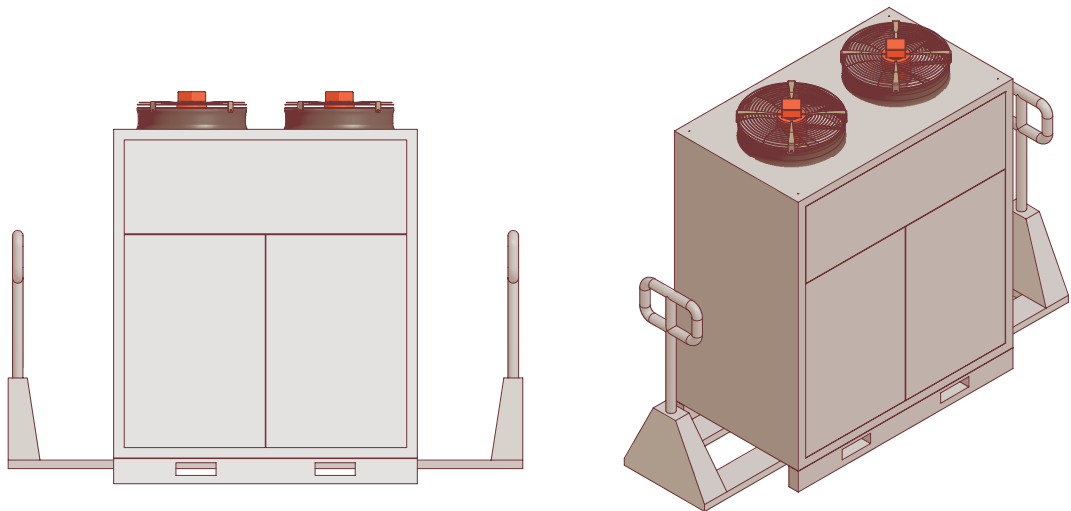

Schematic:
Transport using a lift truck



4.4 Transport Using a Crane

As a rule, the process cooler must always be transported in upright position without water charge !

For the transport of the process cooler, lifting eyes are provided in the upper frame enabling the realisation of a 4-point sling load arrangement.

Load suspension devices

Wire rope slings (lifting rope assemblies) according to DIN 3088 or sling chains (lifting chains) according to DIN 5687/5688 are to be used. Either load suspension device complies with the requirements of a sling with equal rope or chain lengths.

Rope inclination angle

Ensure that the rope inclination angle as shown in the illustration is complied with.

Lifting rate

Keep lifting rate to a minimum
($V_{\text{lift}} < 10\text{m/min}$ - precision lifting, jerk-free lifting)

Depositing the process cooler

To prevent any distortions of the lower frame from occurring, the process cooler must be lowered onto a level surface.

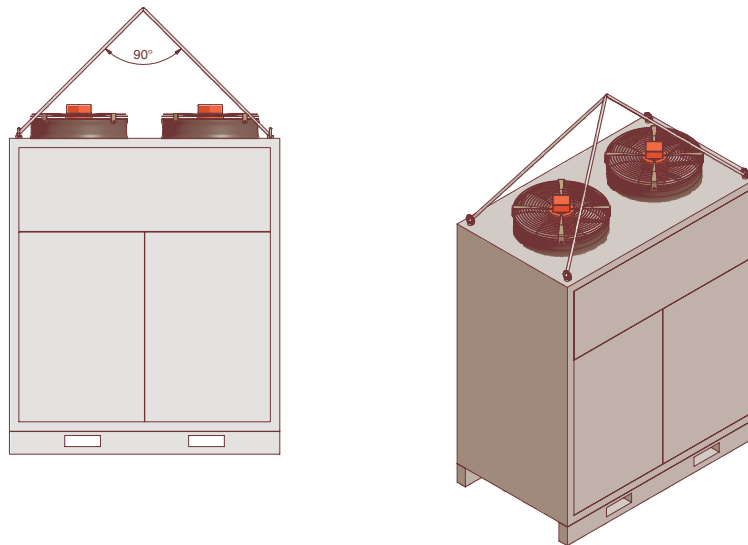

Schematic: Transport using a crane

4.5 Storage of the Process Cooler

This process cooler must be stored on a level surface, or supported on additional square beams, in a dry room, protected from frost.

Permissible storage temperatures: -40°C to $+60^{\circ}\text{C}$.

For storage in ambient temperatures below 0°C , it is imperative that decommissioning measures be taken.

(See Chapter Decommissioning)

5. INSTALLATION

The safety notices contained in Chapter 1 must be complied with !



At storage temperatures < 10 °C allow for an appropriate acclimatisation period before turning the unit on (formation of condensation water) !

Remove transport packaging !

5.1 Indoor Installation



With regard to the required room volume for the installation of the process cooler, the requirements as per Chapter 1.5.1 (Installation) must be complied with.

The process cooler must be installed in a freeze-proof room on a level, horizontal surface capable of supporting the weight of the unit.
Any attachments to the floor, intermediate spacers or antivibration mounts are not required.
The process cooler and the equipment to be cooled must always be installed at the same level.



For different installation conditions, consult the manufacturer.

To ensure trouble-free operation of the process cooler as well as to provide adequate access for the performance of maintenance and repair work, the minimum clearances must be maintained during installation.
(See also Dimensions)

These installation requirements ensure that the cooling air can be drawn in and discharged without obstructions. It can thus be largely prevented that the hot air discharged in upward direction is reintroduced into the process cooler (air short-circuiting).

Moreover, adequate air circulation for carrying off the heat at the installation site must be ensured.

5.2 Outdoor Installation (Option)

If the process cooler is to be installed outdoors it must be equipped with this option.



In case the process cooler is installed outdoors, applicable local or national regulations concerning the protection of waterbodies/groundwater as well as noise level restrictions must be observed !

Electro-technical connection

The process cooler must be provided with a separate power feed.
It must not be supplied with power from the laser control cabinet.

When the laser equipment is placed out of service during the frost period, the disconnect switch of the process cooler must remain in the „on“ position so that the pumps and the electric heater are in the Standby mode.

To maintain the system at operating temperature (approx. 21°C) due to the danger of freezing during a shut-down period, the process cooler is equipped with the following components:
Process cooler with separate disconnect switch.

Laser circuit

- Tank heater



Do not disconnect the process cooler from the power supply when there is danger of frost.

DI water circuit

- Pump start-up control

If the temperature in the DI water circuit falls to 19°C, the pump is activated. The pump is deactivated at 24°C.

To ensure trouble-free operation of the process cooler as well as to provide adequate access for the performance of maintenance and repair work, the minimum clearances - as shown on the diagram - must be maintained when installing the unit (all data in mm).

Use weather-proof shelter.

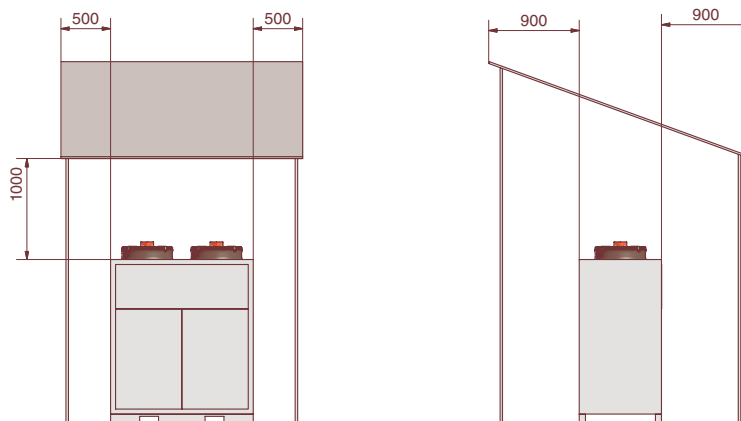

Schematic: Process cooler with weather-proof shelter

6. ASSEMBLY



The safety notices contained in Chapter 1 must be complied with!

6.1 Connection of Water Piping

The nominal widths of the pipes for the external water circuit must be selected on the basis of the available pump pressure and the expected pressure losses in the circuit of the equipment to be cooled.

The water pipes can be of the rigid or flexible type. The materials used in the equipment to be cooled must be chemically compatible with the water in order to prevent any corrosion damage. (See also Chapter Commissioning)



The supplied shut-off valves must be mounted on-site. When the on-site piping system is installed by the customer, care must be taken to ensure that the pipe system is free from impurities (lines may have to be flushed prior to connecting the process cooler)

6.2 Electro-Technical Connection

Activities to be performed:

Remove panel assemblies on the operator side

Working from below, pass the connecting cable through the cable gland provided in the base plate for this purpose (on the left or right, depending on the process cooler)

Route cable properly inside the process cooler and feed it through the screwed cable gland into the control cabinet

Establish electro-technical connection in accordance with the wiring diagram (see Appendix)

The process cooler is ready for connection to a remote control. In the condition as delivered, a jumper wire is inserted between the terminals.

The common fault indicator is wired to the terminal in the form of a potential-free contact. (See also wiring diagram in the Appendix).

7. COMMISSIONING



The safety notices in Chapter 1 must be complied with !

At storage temperatures $<0^{\circ}\text{C}$ allow for a sufficient acclimatisation period before turning on the unit (formation of condensation water). The process cooler is designed exclusively for the cooling of water. Only water complying with IPG specifications may be used for filling the water circuits !



The disconnect switch is located either on the laser equipment control unit or on the process cooler.

The term „disconnect switch“ is used for both situations in the description below.

7.1 Laser Circuit

Place disconnect switch to the „0“ position

Place all motor protecting switches and automatic circuit breakers of the process cooler to the „0“ position

Remove front panel assemblies

Remove tank filler cap

Fill up tank with water up to the -MAX- mark on the liquid level indicator
(water temperature: room temperature)

Turn all shut-off valves to the „OPEN“ position

Vent pump via the vent screw on the pump housing (see Section 7.3)

Place disconnect switch to the „1“ position

Place circuit breakers and motor protecting switches for the laser circuit pump and fans to the „1“ position

(see wiring diagram)

Enable voltage of laser equipment

Check pump and fan for proper direction of rotation

(see arrow on pump housing)



In the event that the pump rotates in the wrong direction, disconnect the process cooler from the mains power supply and reverse any 2 phases of the main power cable.

Visually inspect entire water circuit for leaks

Check that the water level is within the permissible range by inspecting the liquid level indicator and top up with water, if necessary

Mount tank filler cap

7.2 DI-Circuit

Place disconnect switch to the „0“ position
 Place all motor protecting switches and automatic circuit breakers of the process cooler to the „0“ position
 Remove front panel assemblies
 Remove tank filler cap
 Fill up tank with de-ionised water up to the -MAX- mark on the liquid level indicator (water temperature: room temperature)
 Turn all shut-off valves to the „OPEN“ position
 Vent pump via the vent screw on the pump housing (see Section 7.3)
 Place disconnect switch to the „1“ position
 Place circuit breakers and motor protecting switches of the DI circuit pump and fans to the „1“ position
 (see wiring diagram)
 Enable voltage of laser equipment
 Check pump and fan for proper direction of rotation
 (see arrow on pump housing)



In the event that the pump rotates in the wrong direction, disconnect the process cooler from the mains power supply and reverse any 2 phases of the main power cable.

Visually inspect entire water circuit for leaks
 Check that the water level is within the permissible range by inspecting the water level indicator and top up with de-ionised water, if necessary
 Mount tank filler cap

After the two water circuits have been put into operation:

Mount panel assemblies
 Acknowledge (reset) any non-reset fault conditions at the control and operating unit
 Check preset values
 (see Chapter Operation)

Turn motor protecting switches of the compressors to the „1“ position
 (see wiring diagram in the Appendix).
 Acknowledge (reset) any fault alarms that may still be active

The process cooler is ready for operation, and the control and operating unit now takes over the control of the water outlet temperatures.



**Depending on the specific version, the process cooler is optionally equipped with a control switch, a remote control unit or a stand-by button (control On /Off).
 See wiring diagram**

7.3 Bleeding Air From Pumps

DI circuit (CHI pump)

1. Remove the filler plug on the pump housing.
2. Allow pump to run until DI water emerges. Check for proper direction of rotation.
3. Re-install the filler plug and tighten firmly.

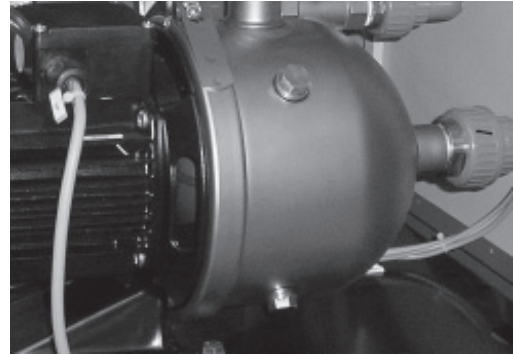
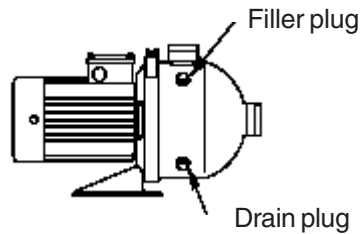

Laser circuit (CR pump)

1. Remove filler plug and slowly fill pump with water.
2. Re-install the filler plug and tighten firmly.
3. Operate the pump. Check for proper direction of rotation.
4. Bleed pump using the bleed valve in the pump head.
5. Close bleed valve as soon as water emerges from the valve.

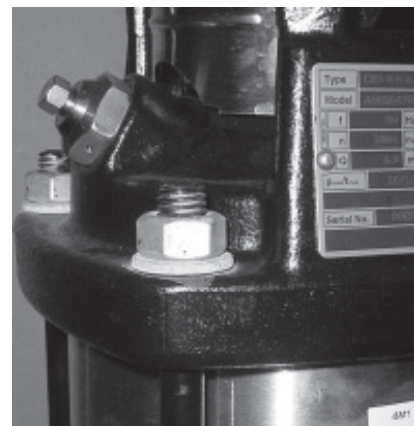
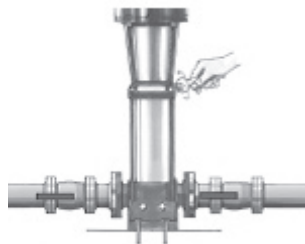
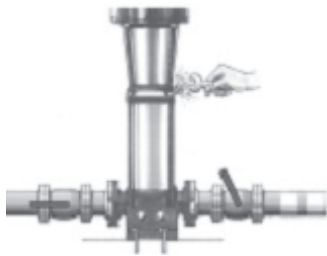



7.4 Hydraulic Settings Upon Frequency Change

This process cooler is of dual frequency design and can therefore be operated both at 50 Hz and 60 Hz.

The frequency at which the process cooler was tested at the factory and the conditions for which the factory settings were made can be seen from the adhesive label located underneath the nameplate.

If the process cooler is to be operated at a different frequency, the following hydraulic settings must be made:

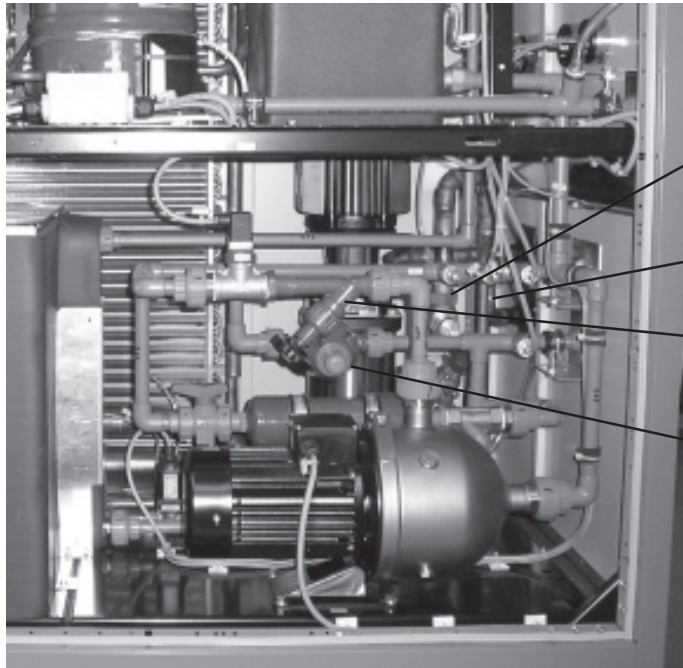

Branch control valve
Laser-Circuit

Overflow valve
Laser-Circuit

Slanted seat valve

DI-Circuit

Overflow valve
DI-Circuit

Settings of DI-Circuit

1. Set the setpoint of the water outlet temperature to the maximum possible setpoint value firstly to prevent the compressor from starting up and secondly to avoid any possible low pressure fault.
To this end, press the "Set button" and the "UP button" on the controller.

Settings of Laser-Circuit



Settings of DI-Circuit

2. Close the slanted seat valve to prevent any liquid hammer during the pump start-up.
Direction of rotation: right.



3. Remove the protective cap from the overflow valve.



4. Loosen the lock nut using a flat wrench.
Direction of rotation: left.



5. Close the overflow valve using an hexagon key.
Direction of rotation: right.



Settings of Laser-Circuit

2. Close the branch control valve to prevent any liquid hammer during the pump start-up.
Direction of rotation: right.



3. Loosen cap 1, unscrew slightly (do not unscrew all the way! Water will emerge!);

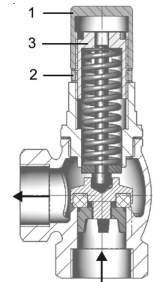

4. Loosen lock nut 2 and screw it in direction of cap and lock it with same.

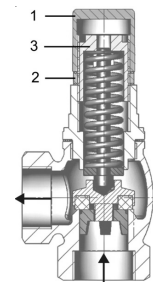

5. Close the overflow valve by screwing in the movable pressure screw 3 (in clockwise direction) = higher opening pressure
Direction of rotation: right

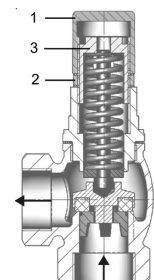

Settings of DI-Circuit

Settings of Laser-Circuit

6. Make sure the tank is adequately filled and start up the process cooler by actuating the main switch.



7. Open the slant seat valve until the desired flow pressure can be read off the pressure gauge.



7. Open the branch control valve until the desired flow pressure can be read off the pressure gauge.



8. Open the overflow valve using a hexagon key until the outlet pressure reading on the pressure gauge decreases and the return pressure increases.
Direction of rotation: left



8. Open the overflow valve using pressure screw 3 exactly until the outlet pressure reading on the pressure gauge decreases and the return pressure increases.
(in counter-clockwise direction) = lower opening pressure

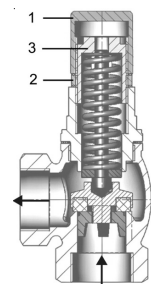

9. Tighten the lock nut using the flat wrench.
Direction of rotation: right.



9. Tighten lock nut 2.
Direction of rotation: right.

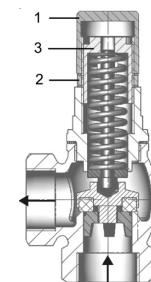

Settings of DI-Circuit

10. Cover the set screw with the protective cap

**Settings of Laser-Circuit**

10. Cover set screw 2 with protective cap 1

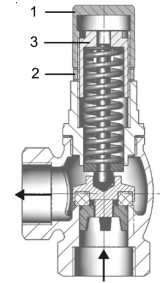

11. Set the desired setpoint value of the water outlet temperature. To this end, press the "Set button" and the "DOWN button" on the controller.

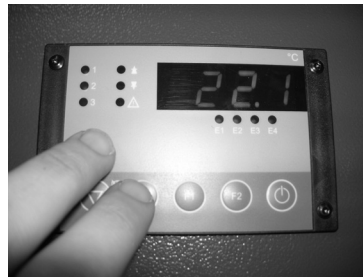

7.5 Refrigeration Circuit

After the activities on the water circuit have been completed, the motor protecting switches of the compressors have to be placed to the -1- position (see wiring diagram in the Appendix). Reset/acknowledge all non-reset fault alarms on the control and operating unit. The process cooler is ready for operation and the control and operating unit assumes the control of the water outlet temperature.



Check fan(s) and pump(s) for proper direction of rotation. Check setpoint setting and correct, if necessary.



8. DECOMMISSIONING

The safety notices in Chapter 1 must be complied with !

Disconnect process cooler from power supply.
Completely drain water circuit, including tank, pump(s), piping and filters
(see flow diagram of pipes and instruments in the Appendix)



CAUTION!

**Do not use pump to drain the process cooler.
(Dry running of the pump will lead to the destruction of the shaft seal)**



Take freeze protection measures (consult manufacturer)

9. SHUTDOWN IN EMERGENCIES



The safety notices contained in Chapter 1 must be complied with !

Turn disconnecting device (main switch) on the process cooler to "off"

10. ENVIRONMENTAL REQUIREMENTS

When repairing or placing the process cooler out of service (decommissioning), the environment-relevant requirements regarding recovery, reuse and disposal of fuels/oils and components according to DIN EN 378 must be complied with.



The operator of the process cooler is responsible for the proper disposal of used fuels, oils and system components.

The disposal of the water containing additives is to be effected in agreement with the competent local authorities.

11. OPERATION OF CONTROL AND OPERATING UNIT



Button 1: UP

Use the UP button to advance to the next higher channel.

Button 2: DOWN

Use the DOWN button to move to the next lower channel.
It is also used for resetting fault alarms.

Button 3: Function key (Option)

Various functions are assigned to this button by way of parameterisation, see parameter A83.
(Standby mode, direct control of a contact, setpoint input P1)

Button 4: SET

Press the SET button to display the setpoint S1.
The setpoint is increased by additionally pressing the UP button, the setpoint is decreased by additionally pressing the DOWN button.

Button 5: Standby

Various functions are assigned to this button by way of parameterisation, see parameter A82.
(Standby mode, direct control of a contact, setpoint input P1)

Lamp 1:

Status display of output K1

Lamp 2:

Status display of digital input E1

Lamp 3:

Status message temperature control active or inactive

Setting Option

The setting of the controller, the so-called parameterisation, is performed at various display levels. Said display levels are accessible via the front-panel keypad whereby the access to safety-relevant parameters has intentionally been made more difficult. The first display level only permits access to the setpoint value and, if required, to the parameters that may have been assigned to the additional keys. These settings can be accomplished by direct key actuation.

At the other display levels all control parameters can be set. Access to these display levels requires a password.



Please note that the value is transferred to the non-volatile memory and is therefore retained even in the event of a power failure. After the setting operation is complete, the UP or DOWN button is always to be released first, i.e. before the SET button is released. This applies to the setpoint and all parameters alike.

12. MAINTENANCE



The safety notices contained in Chapter 1 must be complied with!

Disconnect process cooler from mains voltage prior to opening the unit!

No specific refrigeration technology know-how is required for the performance of maintenance activities. This work can be carried out by a properly trained person with appropriate special knowledge.

Item to be serviced	Interval	Activity
Process cooler in general	2 weeks	Visual inspection of air filter mat for contamination Visual inspection of refrigeration cycle for leaks In the case of oil leaks, call the customer service
Water circuit Cooling water Filter in water circuit DI cartridge	2 weeks	Visual inspection of water circuit for leaks Check water level, top up Clean filter at regular intervals or replace Check water quality Check DI cartridge, or replace
Cooling air circulation Filter mat Condenser	1 month	Clean filter mat or replace Clean condenser with compressed air, do not damage fins

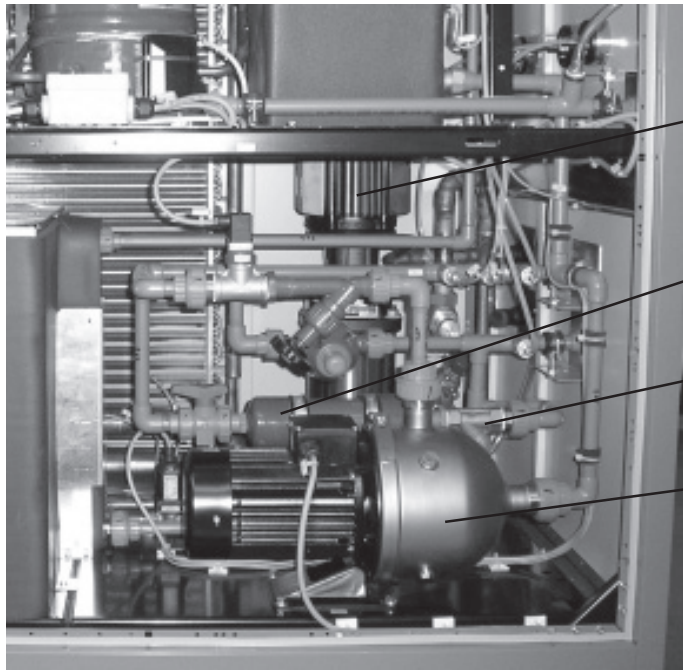

Pump of Laser-circuit

DI-Filter

After-filter of DI cartridge

Pump, demineralised circuit

12.1 Cleaning After-Filter of Ion Filter

Preparatory Steps

1. Turn off process cooler and take appropriate lock-out procedures to prevent accidental restarting.
2. Remove right cover panel at the front of the process cooler.
3. Close shut-off valve of DI cartridge.

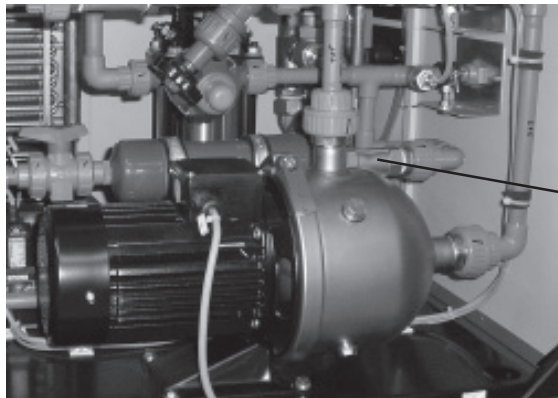

After-filter of DI cartridge

Cleaning the filter:

1. Slowly open lock nut of filter.
2. Mop up emerging water.
3. Pull perforated tube out of housing.
4. Clean perforated tube, replace if necessary.
5. Blow out perforated tube with compressed air, if necessary.
6. Install perforated tube.
7. Tighten lock nut.

12.2 Replacement of Ion Filter

Preparatory Steps

1. Turn off process cooler and take appropriate lock-out procedures to prevent accidental restarting.
2. Remove right cover panel at the front of the process cooler.

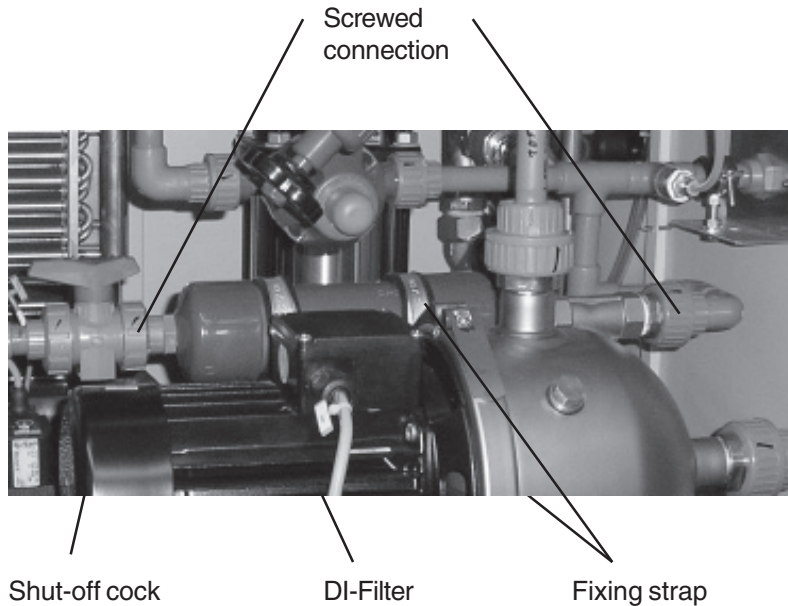

Removal of ion filter:

1. Close shut-off cock.
2. Remove screwed connections.
3. Loosen fixing device and remove fixing strap.
4. Remove ion filter together with after-filter from the process cooler.
5. Mop up any emerging water.

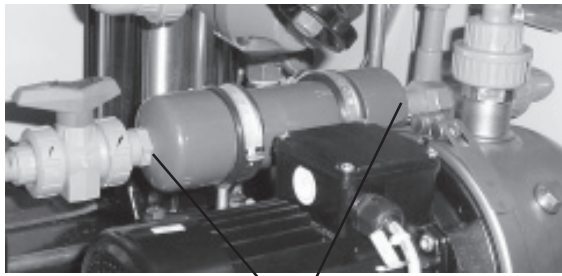
Replacement of ion filter:

Screws



1. Loosen screws
2. Replace ion filter
3. **Use Teflon tape on the threaded screw connection**

Install the ion filter including after-filter in the reverse order of sequence.



It is recommended that you replace the de-ionised water (DI water) in the tank following the replacement of the ion filter.

13. REQUALIFICATION TESTS



The safety notices contained in Chapter 1 must be complied with!

Throughout the service life of the process cooler, monitoring and inspection (not covered by the warranty) must be carried out in compliance with national regulations!

In the absence of relevant national provisions with respect to requalification tests, device-specific tests should be performed in accordance with EN 378-2.

Scope of tests

Test Designations	Monitoring	Checks		
	Visual inspection	Pressure test	Refrigerant leak test	Funct. check HP pressostat
M1	X	X	X	X
M2	X		X	X
M3	X		X	
M4	X		X ¹⁾	X

Monitoring and testing must be carried out by a competent person (as defined in EN13313) or a specialist refrigeration company in compliance with environmental requirements with respect to reuse and disposal of fuels/oils and component parts.

Definition of test designations

- M1** Requalification tests must be carried out following every intervention in the refrigeration cycle due to required repair or service activities (replacement of components, elimination of leaks, replacement of filter-drier cartridges).
- M2** Requalification tests must be carried out prior to restarting a process cooler following a shut-down period of more than 2 years.
- M3** Following the initial start-up of the process cooler at the end customer's site, requalification tests must be carried out whenever the unit is moved to a new location. Due to special transport safety measures, the relocation of the process cooler from the manufacturer's plant to the end user's site does not result in any statistically significant increase in the failure rate and no requalification test is therefore required.
- M4** The requalification test is to be performed once a year.
¹⁾ The refrigerant leak checks must be performed in accordance with Regulation (EC) No. 842/2006:
Refrigerant charge (see name plate)
 < 30 kg annually
 > 30 kg every 6 months

The **visual inspection** covers the following:

Checking the air filter mats of the condenser for cleanliness

Checking the intactness of the joint sealing in the refrigeration cycle (pipe joints at compressor) (red seals)

Visual inspection of the refrigeration cycle for oil leaks in the area of the compressor and condenser connecting lines (suction line, pressure line)

Inspection of the condenser heat exchanger surface and the refrigerant piping for corrosion damage

Inspection of the mounting and attachment of all piping and components for security

Visual inspection of the water circuits for leaks under operating conditions

Check that operating manual is available at/near the process cooler

Check sight glass in the liquid line for any formation of bubbles



The requalification tests must be recorded in the system log.

14. MALFUNCTIONS / TROUBLESHOOTING





The safety notices contained in Chapter 1 must be complied with!

The basis for troubleshooting are the wiring diagram, the flow diagram and the messages displayed on the control panel.

The controlled variable is the main setpoint.

Statusanzeige Status indicator	Störung Problem	Ursache Cause	Behebung Remedy
H1 H2 H3	Voltage not enabled	Power supply disrupted	Check power supply
		Main switch not actuated	Main switch in position -1-
		Control circuit breaker has tripped	Check control circuit breaker
H1 H2 H3 ●	Control voltage not enabled	Remote control not activated	Check remote control, check jumper at terminals in control cabinet as per wiring diagram
		Control switch not turned on	Control switch in position -1-
	Low-pressure pressostat has tripped	Refrigerant shortage caused by a leak in the refrigeration cycle	Check refrigeration cycle for leaks Top up refrigerant, call customer service
		Refrigerator oil was not preheated despite low ambient temperature	After suction pressure rise, pressostat will reset automatically
		Pressostat fails to reset automatically	Check pressostat, call customer service if necessary

Status indicator	Störung Problem	Ursache Cause	Behebung Remedy
H1 H2 H3 	High-pressure pressostat has tripped	Cooling air temperature too high	Heat dissipation to be ensured through increased air changes at the installation site. Actuate reset button on high-pressure pressostat.
		Dirty condenser or filter mat	Clean condenser with compressed air or replace filter mat. Actuate reset button on high-pressure pressostat.
		Fan(s) fail(s) to rotate	Perform functional check of fan. Actuate reset button on high-pressure pressostat.
		Panel assemblies removed from process cooler.	Mount panel assemblies. Actuate reset button on high-pressure pressostat.
		Pressostat fails to switch on	Check pressostat, call customer service if necessary
H1 H2 H3  	Thermal contact of fan has tripped	Motor winding overheated	Allow motor to cool, check thermal contact for continuity, replace fan if necessary
Water shortage indicator light is illuminated	Water below MIN mark	Liquid loss in water circuit	Check water circuit for leaks, fill up water up to the MAX mark.
Indicator lamp of pump(s) fail to illuminate	Motor protecting switch has tripped	Pump motor overload due to mechanical sluggishness	Check pump, replace if necessary Motor protecting switch to position -1-
		Motor overload due to phase failure	Correct phase failure, motor protecting switch in position -1-
Compressor fails to start up	Compressor contactor has been actuated	Star-point klixon of compressor has tripped	Restart after compressor has cooled, time delay of up to 3 hours

PC 160.01-NZ-DIS

(all dimensions in mm)

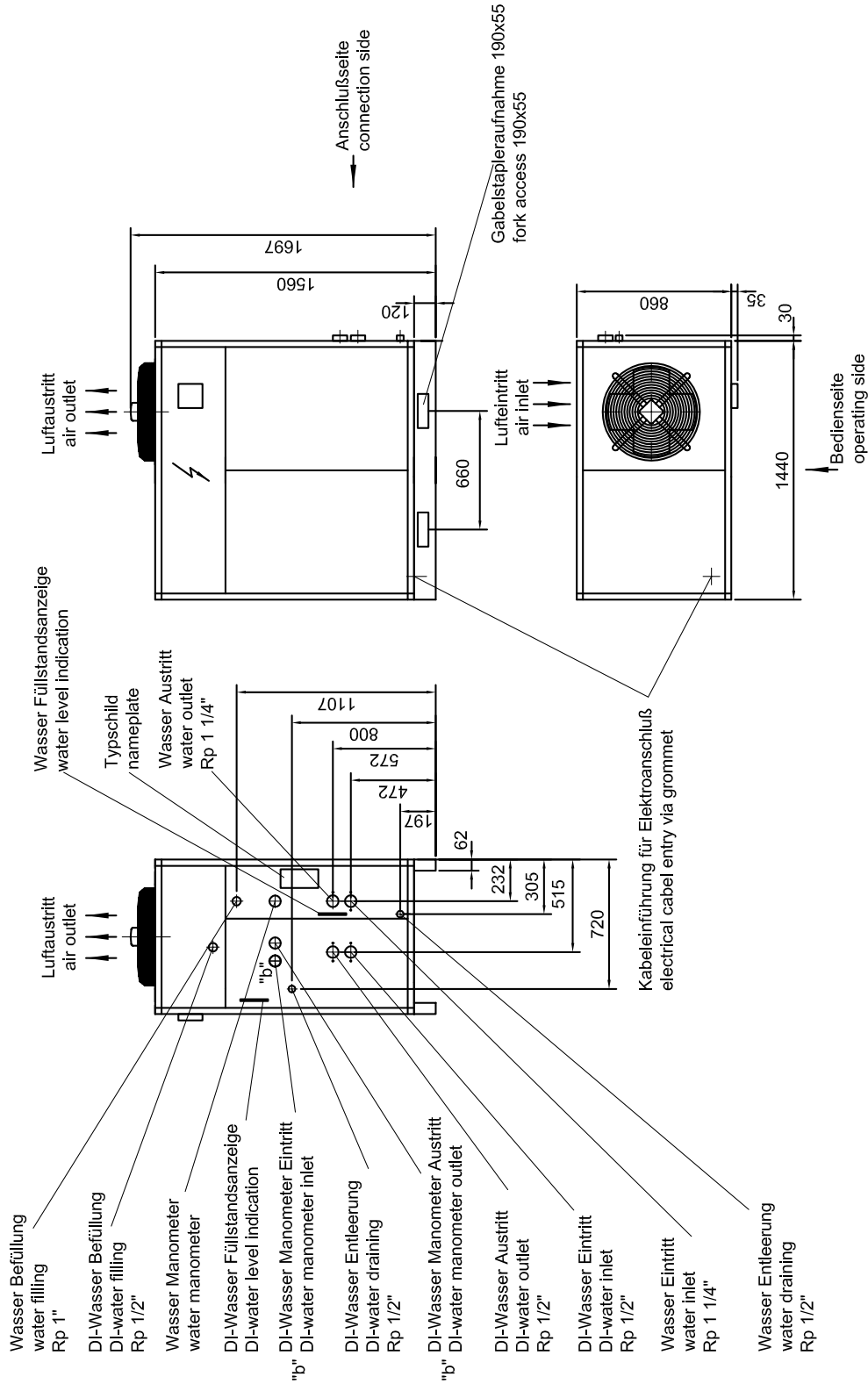

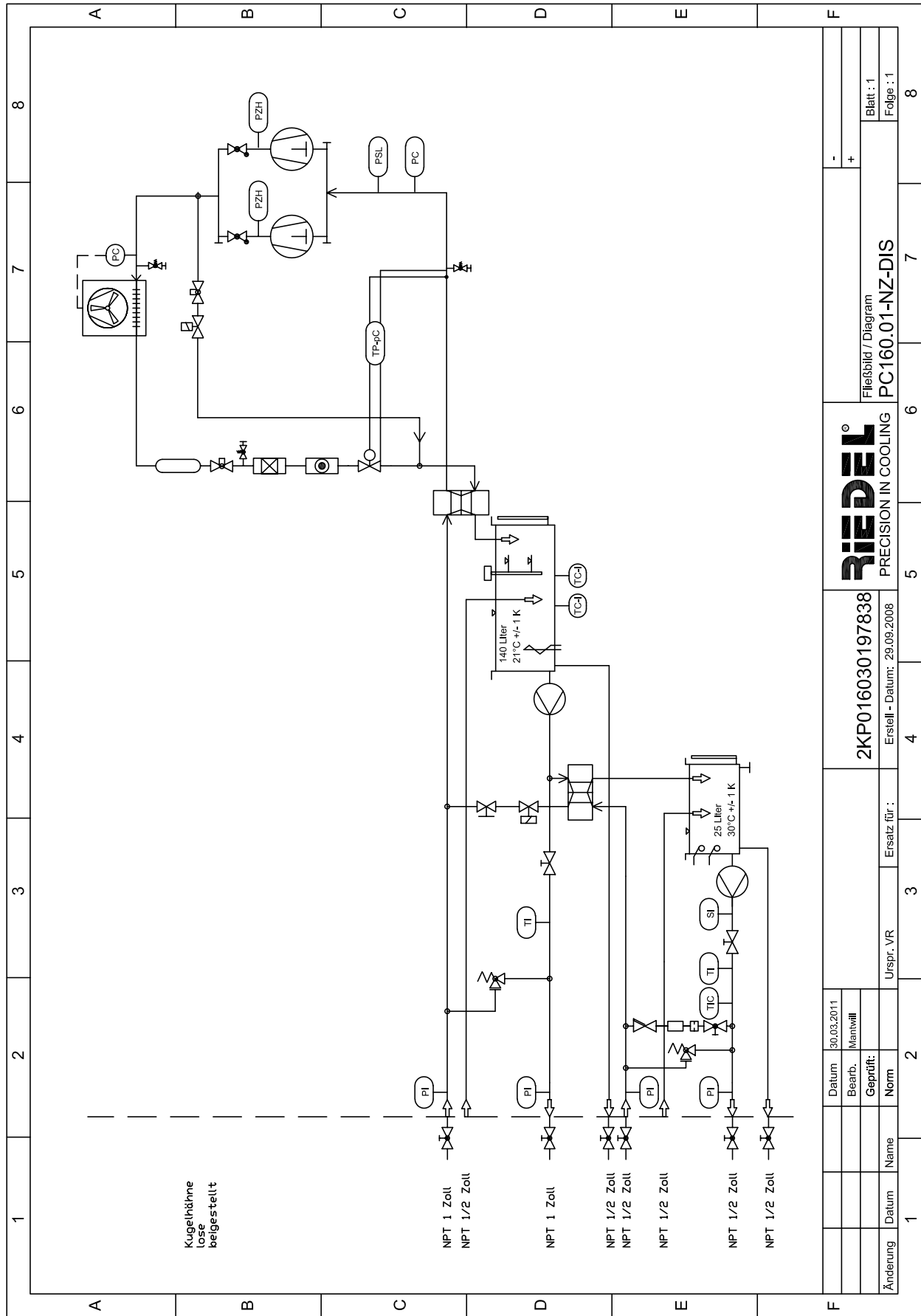

Spare Parts List				
		PC 160.01-NZ-DIS	PC 250.01-NZ-DIS	PC 400.01-NZ-DIS
Item	Designation			
	Refrigeration Cycle			
1	Evaporator	4518024141	4518004181	4518024144
2	Expansion valve			
	... Valve - insert	4518014125	4518024157	4518024188
	... Valve - top part	4518034474	4518034462	4518034462
	... Valve - flange	4518014124	4518014146	4518024158
3	Sight glass	4521554109	4521194101	4521104115
4	Filter drier	4518034248	4518014298	4521254166
5	Shut-off valve	4518034806	4518034807	4518034808
6	Condenser	4518032811	4518032809	4518032815
	Filter mat	4518052884	4518052882	4518052883
7	Fan	4518014115	4518014115	4518014115
8	Fan pressostat	4518035337	4518035337	4518035337
9	Solenoid valve	4521474202	4521474202	4525014134
10	Shut-off valve	4518044261	4518044261	4518044259
11	Non-return valve	4521474105	4518034399	4521104117
12	HP pressostat	4518035338	4518035338	4518035338
13	Compressor	4518034694	4518034470	4518034662
14	LP pressostat	4518035340	4518035340	4518035340
15	LP sw itch	4518035336	4518035336	4518035336
16	Schrader valve	4525014208	4525014208	4525014208
	... Valve - insert	4518044288	4518044288	4518044288
Item	Designation			
	DI Circuit			
21	Tank	4518042875	4518042875	4518042875
22	Float sw itch 1-stage	4518014551	4518014551	4518014742
23	Ball valve - tank draining	4525054111	4525054111	4525054111
24	Pump			
25	Ball valve	4518014686	4518014686	4518014686
26	Conductivity meter	4518044756	4518044756	4518044756
27	Ball valve	4518035082	4518035082	4518035082
28	DI cartridge	4518044745	4518044745	4518044745
29	Strainer	4518045019	4518045019	4518045019
	Strainer tube	4518144189	4518144189	4518144189
30	Overflow valve	4518042896	4518042896	4518042896
31	Sensor - thermometer	4518044286	4518044286	4518044286
32	Sensor - operating thermostat	4518014203	4518014203	4518014203
33	Pressure gauge	4518044237	4518044237	4518044237
34	Pressure gauge	4518044237	4518044237	4518044237
35	Ball valve	4518104126	4518104126	4518104126
36	Ball valve	4518104126	4518104126	4518104126
37	Strainer NPT connections	external	external	external
48	Plate heat exchanger	4518035753	4518035753	4518035753

Spare Parts List				
		PC 160.01-NZ-DIS	PC 250.01-NZ-DIS	PC 400.01-NZ-DIS
Item	Designation			
	Laser Circuit			
41	Tank	4518032822	4518032821	4518032823
42	Ball valve - tank draining	4525054111	4525054111	4525054111
43	Float switch 2-stage	4518034747	4518034747	4518034747
44	Sensor- operating thermostat	4518014203	4518044286	4518014203
45	Sensor-Tank heater	4518014202	4518044266	4518014202
46	Tank heater	4518014368	4518014368	4518014368
47	Pump			
48	Plate heat exchanger	4518035753	4518035753	4518035753
49	Solenoid valve	4518035801	4518035801	4518035801
	... coil	4518014651	4518014651	4518014651
50	Ball valve	4518104126	4518104126	4518104126
51	Ball valve	4518104126	4518104126	4518104126
52	Overflow valve	4518034314	4518034314	4518034314
53	Sensor - thermometer	4518044286	4518044286	4518044286
54	Pressure gauge	4518044237	4518044237	4518044237
55	Pressure gauge	4518044237	4518044237	4518044237
56	Ball valve	4518104126	4518104126	4518104126
57	Ball valve	4518104126	4518104126	4518104126
58	Strainer NPTconn.	external	external	external

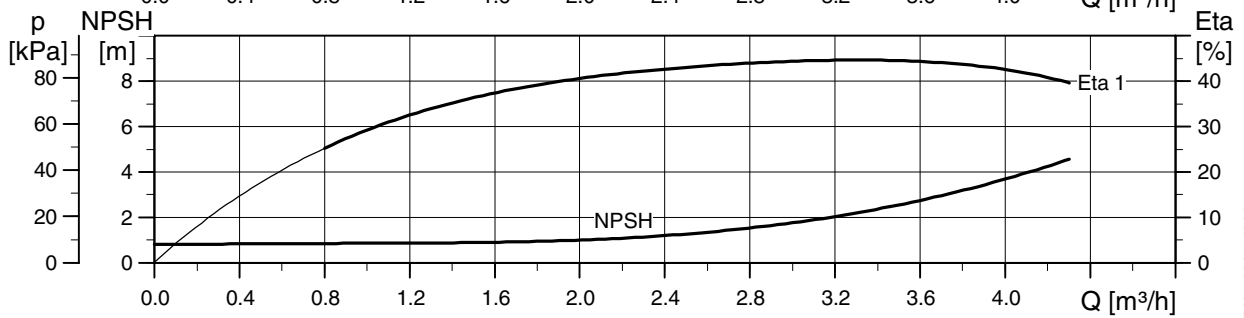
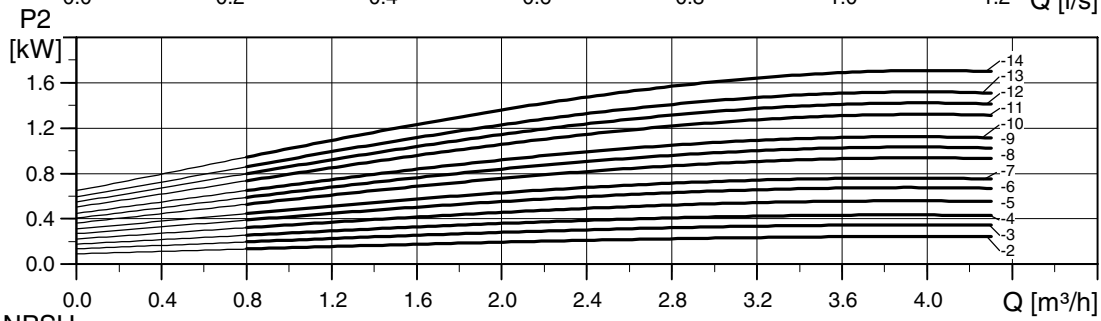
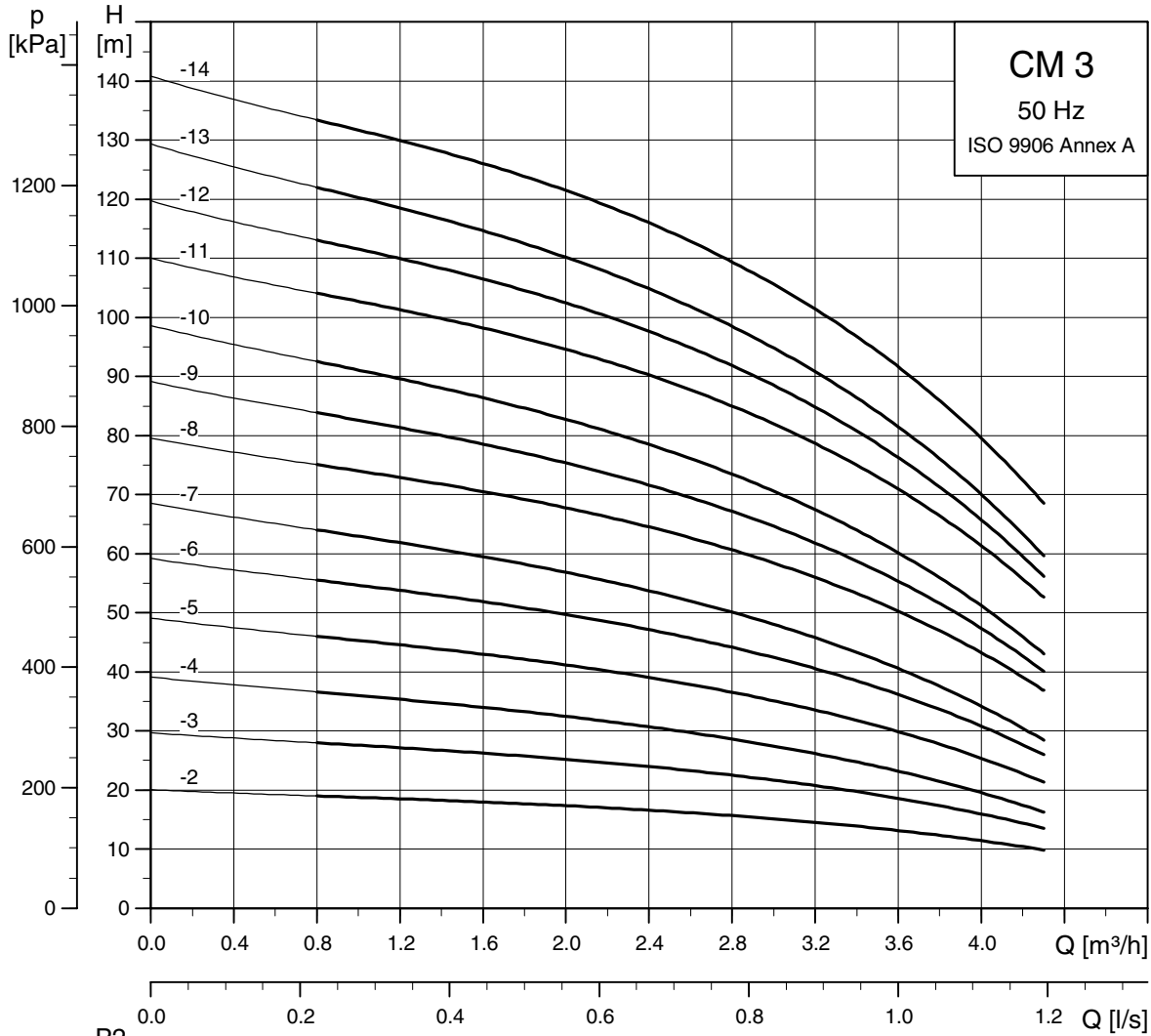

TM04 3335 4308

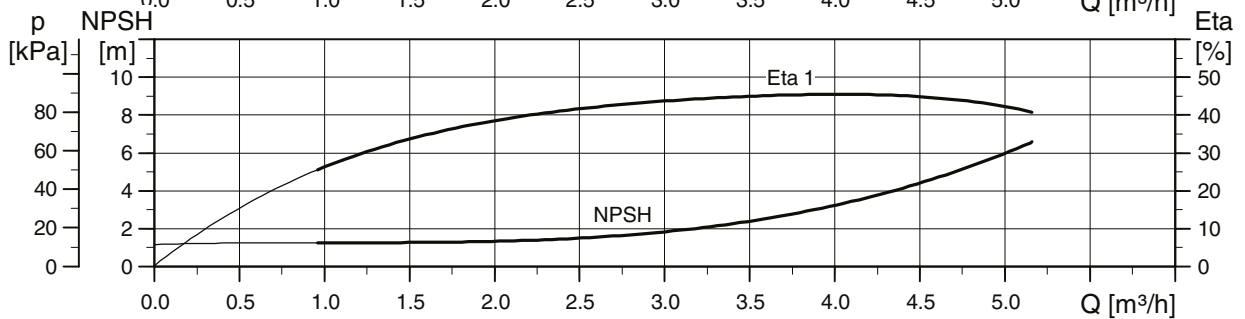
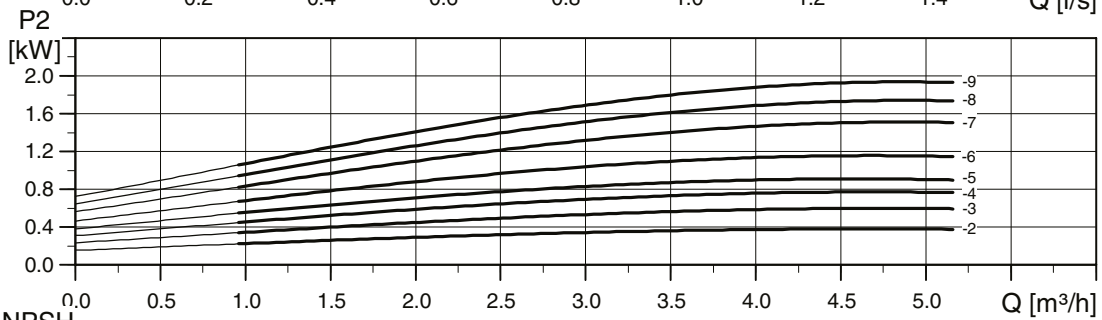
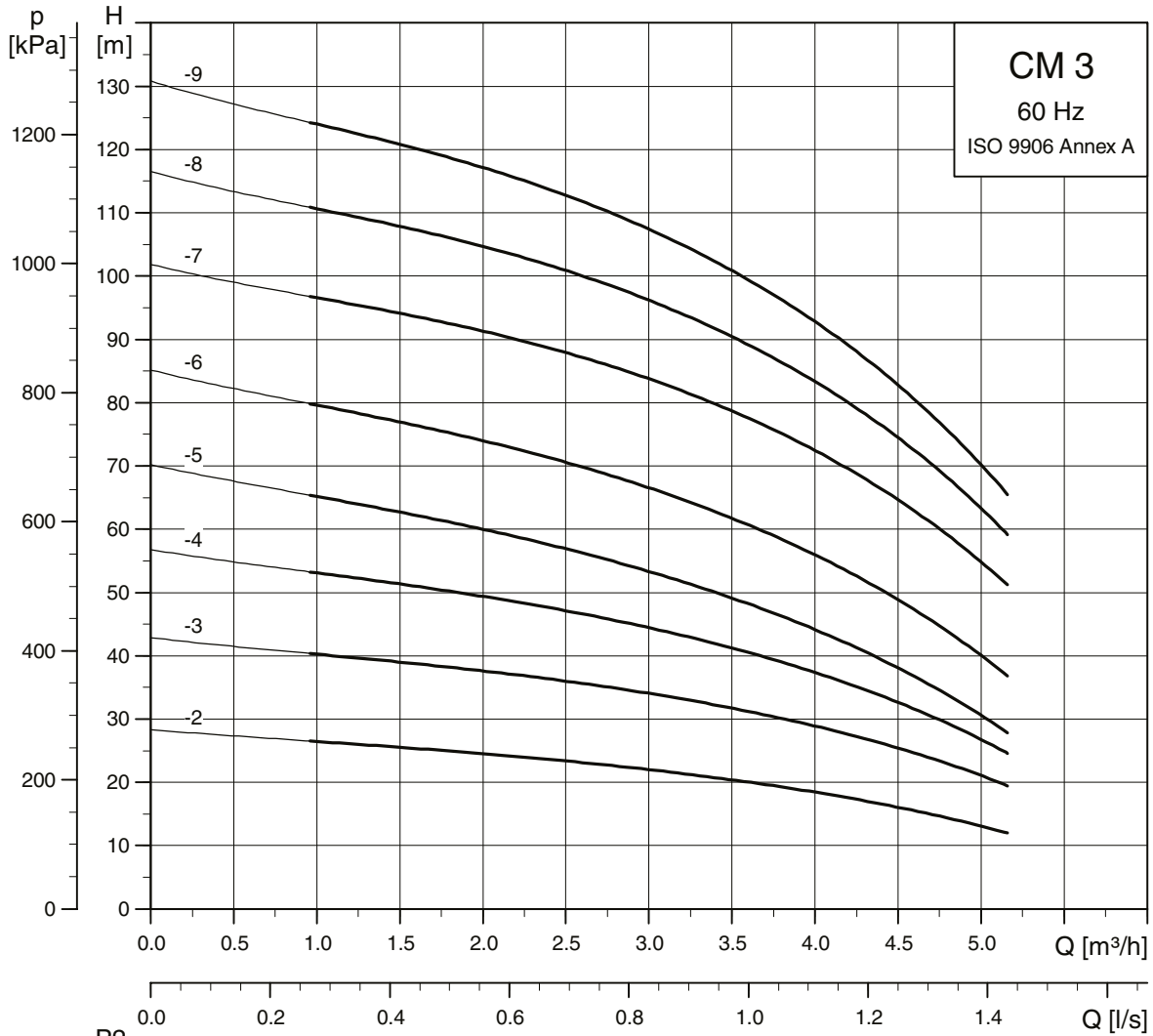

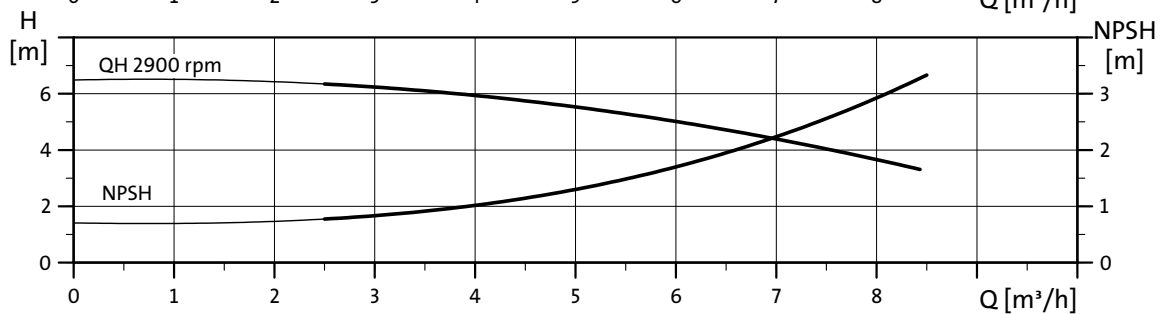
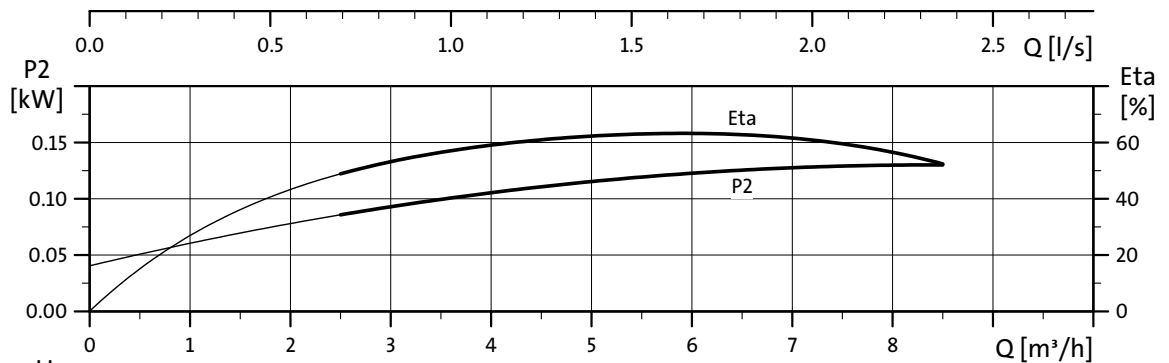
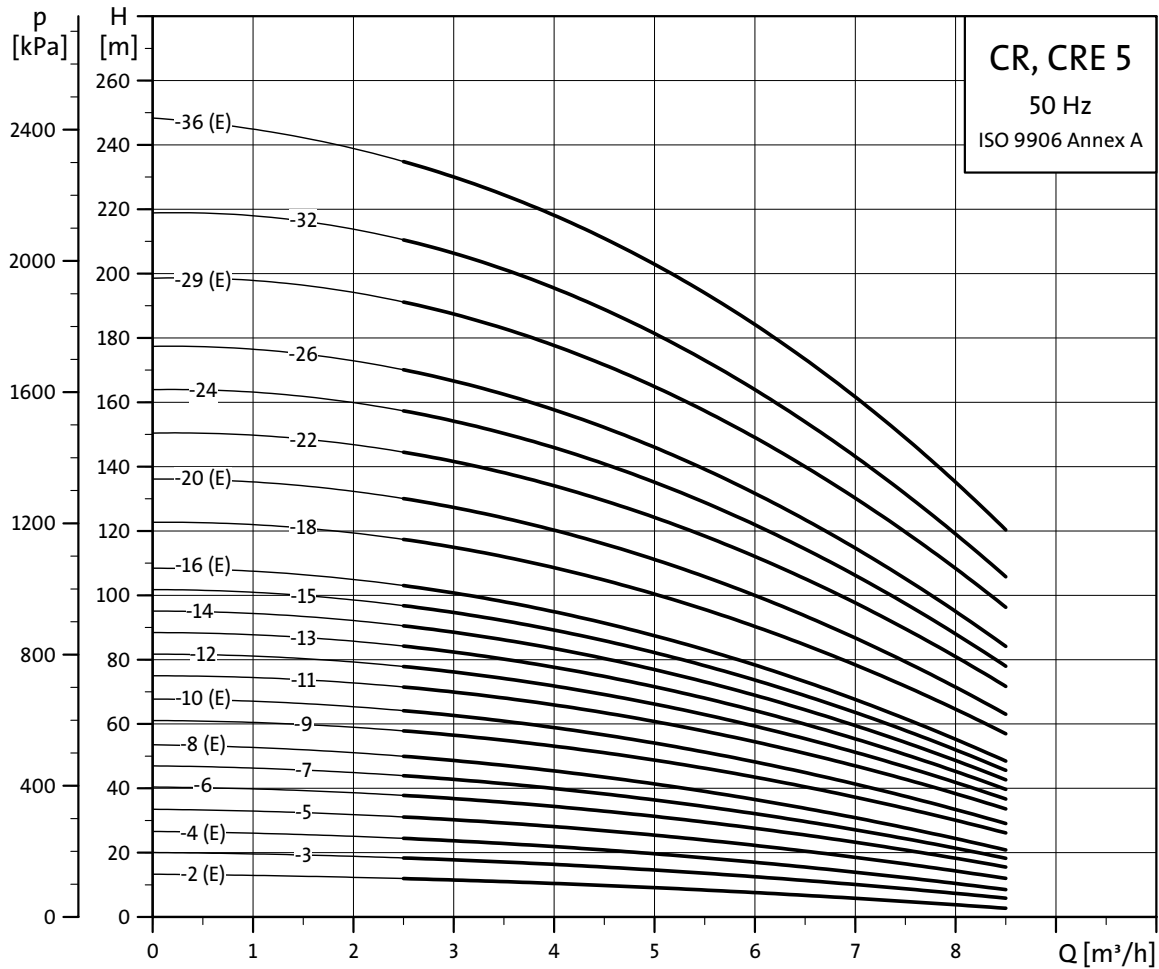

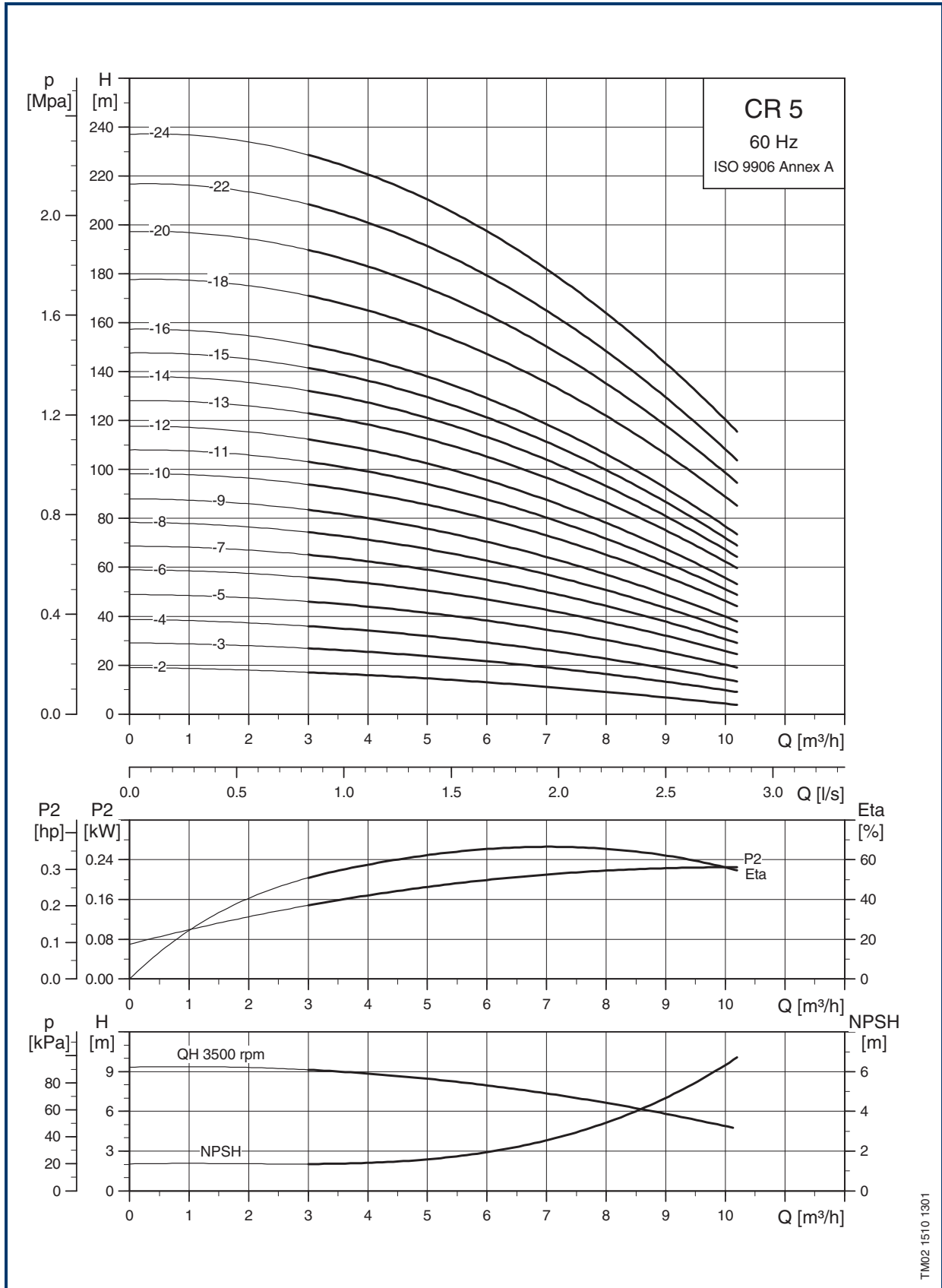

TM02 1510 1301

Muster Anlagenprotokoll

Sample System Log

Gerätetyp / Device type: _____

Baujahr / Year of manufacture: _____

Zul. Betriebsüberdruck / Max. allowable working pressure: _____

Kältemittel / Refrigerant: _____

Kältemittelfüllmenge / Refrigerant charge weight: _____

1 Einzelheiten aller Instandhaltungs- und Instandsetzungsarbeiten

Details of all maintenance and repair activities

2 Menge und Art (neu, wiederverwendet oder recycelt) des eingefüllten Kältemittels, Menge und Art des abgelassenen Kältemittels aus dem Gerät

Whenever the system is charged the amount and type (new, reused or recycled) of the refrigerant charge, and whenever the refrigerant is drained from the WCU, the amount of refrigerant that has been drained

3 Falls eine Analyse eines wiederverwendeten Kältemittels vorliegt, die entsprechenden Ergebnisse eintragen

In the event that an analysis of any reused refrigerant is available, the results there of

4 Die Herkunft des eingesetzten Kältemittels

The origin of any reused refrigerant

5 Änderung und Austausch von Bauteilen des Gerätes

Any modification to and replacement of components of the process cooler

6 Ergebnisse aller regelmäßigen Routineprüfungen

Results of all regular routine tests

7 Längere Stillstandszeiten

Extended shutdown periods

Muster Kurzanweisung

Bitte diese Kurzanweisung sorgfältig ergänzen, ausschneiden, mit einer Folie schützen und gut lesbar am Gerät anbringen !

Sample Quick Reference Guide

Please carefully complete this quick reference guide, cut it out, cover it with protective film and affix it to the unit in an easily accessible place !

Diese Kurzanweisung enthält wichtige Informationen für Notfälle und Störungen !
This short guide contains important information for use in cases of emergency and malfunctions !

**NOTFALL
EMERGENCY**

**Im Notfall ist das Kühlaggregat mit dem
Netztrennschalter auszuschalten !**

**The main switch of the process cooler must be
turned off in emergencies !**

Vom Anwender einzutragen / To be entered by the user :

**ERSTE HILFE
FIRST AID**

Verantwortliche Person
Responsible person: _____

Betriebsleitung
Operating manual: _____

Notarzt
Emergency doctor: _____

Feuerwehr
Fire brigade: _____

Polizei
Police: _____

TECHNISCHE ANGABEN

siehe auch Typschild

TECHNICAL DATA

see also data plate

Gerätetyp / Device type: _____
Kältemittel / Refrigerant: _____
Kältemittelformel / Refrigerant formula: _____
Kältemittelfüllmenge / Refrigerant charge: _____
Zul. Betriebsüberdruck / Max. allow. working pressure _____

Baujahr / Year of manufacture: _____
Seriennummer / Serial number: _____
Stromart / Power requirements: ____ V / _ Ph / ____ A
Nennstrom / Rated current: _____

**Gerätehersteller
Kundendienst
Equipment manufacturer
Customer service**

Glen Dimplex Deutschland GmbH
GB RIEDEL Kältetechnik
Am Goldenen Feld 18
D-95326 Kulmbach
Telefon: +49 (0) 9221 / 709 555
Telefax: +49 (0) 9221 / 709 549
e-mail: info@Riedel-Cooling.de
<http://www.Riedel-Cooling.com>

electrical documentation

Elektro-Dokumentation

customer Auftraggeber	:	
device type Gerätetyp	:	PC 160.01-NZ-DI-S
project number Projektnummer	:	97838
drawing number Zeichnungsnummer	:	2KP016030197838
drawing num. customer Zng.Nr. Auftraggeber	:	



Glen Dimplex Deutschland GmbH
Geschäftsbereich RIEDEL

Am Goldenen Feld 18
D-95326 Kulmbach

Telefon: +49 (0)9221 / 709 545
Telefax: +49 (0)9221 / 709 529

e-mail: info@riedel-cooling.com
<http://www.riedel-cooling.com>

date		20.04.2011		cover sheet		page 1	
user		SCH		1		97838	
reviewed				RIEDEL		PRECISION IN COOLING	
name		norm		supersedure for		supersedure with	
date		name		origin		2. pg.	
P. alteration							

technical datas

Technische Daten · données techniques

nom. voltage
Nennspannung
tension nominale
: 3/PE ~ 50Hz 400V ±10%
3/PE ~ 60Hz 460V ±10%

max. current consumption : 30.0A
Max. Stromaufnahme
consommation de courant max.
31.5A

max. fusing
Max. Vorsicherung
protection préliminaire max.
: 35A RK5 type fuses only

max. power consumption : 16.0kW
Max. Leistungsaufnahme
consommation de puissance max.
20.0kW

apparent power
Scheinleistung
Puissance apparente
: 20.0kVA
25.0kVA

control voltage
Steuerspannung
tension de commande
: DC 24V

colour
Farbe
couleur
: RAL 7035 lacquer glossy

wiring colors (DIN EN 60204-1)

Verdrahtungsfarben · couleurs de câblage

short marks according to DIN IEC 757
Kurzzeichen nach DIN IEC 757 · symbole selon DIN IEC 757

black
Schwarz
noir
BK
(RAL 9005)
: **main circuits AC and DC**
Hauptstromkreise AC und DC
circuits électriques principaux AC et DC

light blue
Hellblau
bleu clair
BU
(RAL 5015)
: **neutral conductor**
Neutralleiter
conducteur neutre

red
Rot
rouge
RD
(RAL 3000)
: **control circuits AC 230V**
Steuerstromkreise AC 230V
circuits électriques de commande AC 230V

red
Rot
rouge
RD
(RAL 3000)
: **control circuits AC 12V/24V**
Steuerstromkreise AC 12V/24V
circuits électriques de commande AC 12V/24V

dark blue
Dunkelblau
bleu sombre
BU
(RAL 5010)
: **control circuits DC 24V**
Steuerstromkreise DC 24V
circuits électriques de commande DC 24V

orange / yellow
Orange / Gelb
orange / jaune
OG
(RAL 2003)
YE
(RAL 1021)
: **interlock circuits, separate source voltage**
Verriegelungsstromkreise, Fremdspannung
circuits électriques de verrouillage, tension étrangère
(yellow units for UL/CSA only)
(Gelb nur bei Anlagen nach UL/CSA)
(jaune uniquement pour les installations selon UL/CSA)

violet
Violett
violet
VT
(RAL 4005)
: **measuring lines**
Messleitungen
lignes de mesure

green-yellow
Grün-Gelb
vert-jaune
GNYE
(RAL 6018-1021)
: **protective system**
Schutzleitersystem
système de conducteur de protection

date	20.04.2011
user	SCH
reviewed	
name	norm
date	
iteration	

R. alteration

origin

supersedure for

supersedure with

RIEDEL
PRECISION IN COOLING

cover sheet
2

technical datas

97838

page 2
2 / 2

directory · Inhaltsverzeichnis

No	planning type Planart	2nd designation layer 2. Bezeichnungsebene	page Blatt	page-designation Blattbenennung	special notes Sondervermerke	user Bearbeiter	date Datum	revision Revision	date Datum
1	cover sheet Deckblatt		1			SCH	20.04.2011		
2	cover sheet Deckblatt		2	technical datas Technische Daten		SCH	20.04.2011		
3	directory Inhaltsverzeichnis		1			SCH	20.04.2011		
4	directory Inhaltsverzeichnis		2			SCH	20.04.2011		
5	circuit diagram Stromlaufplan		1	power supply, control voltage Einspeisung, Steuerspannung		SCH	20.04.2011		
6	circuit diagram Stromlaufplan		2	load circuit compressor Lastkreis Verdichter		SCH	20.04.2011		
7	circuit diagram Stromlaufplan		3	load circuit condenser-fans Lastkreis Kondensatorventilatoren		SCH	20.04.2011		
8	circuit diagram Stromlaufplan		4	reserve Reserve		SCH	20.04.2011		
9	circuit diagram Stromlaufplan		5	load circuit pumps Lastkreis Pumpen		SCH	20.04.2011		
10	circuit diagram Stromlaufplan		6	load circuit healings Lastkreis Heizungen		SCH	20.04.2011		
11	circuit diagram Stromlaufplan		7	control circuit pump-control Steuerkreis Pumpensteuerung		SCH	20.04.2011		
12	circuit diagram Stromlaufplan		8	control circuit pressostats Steuerkreis Pressostate		SCH	20.04.2011		
13	circuit diagram Stromlaufplan		9	control circuit thermorelays Steuerkreis Thermokontakte		SCH	20.04.2011		
14	circuit diagram Stromlaufplan		10	control circuit compressor-control Steuerkreis Verdichtersteuerung		SCH	20.04.2011		
15	circuit diagram Stromlaufplan		11	control circuit fan-control Steuerkreis Ventilatorsteuerung		SCH	20.04.2011		
16	circuit diagram Stromlaufplan		12	control circuit control demi-circuit Steuerkreis Regelung Demi-Kreis		SCH	20.04.2011		
17	circuit diagram Stromlaufplan		13	control circuit heating control system Steuerkreis Heizungssteuerung		SCH	20.04.2011		
18	circuit diagram Stromlaufplan		14	control circuit transducer Steuerkreis Messwandler		SCH	20.04.2011		
19	circuit diagram Stromlaufplan		15	control circuit accumulative-fault Steuerkreis Sammelstörung		SCH	20.04.2011		
20	circuit diagram Stromlaufplan		16	interface Geräteschnittstelle		SCH	20.04.2011		
21	terminal connection diagram Anschlussplan		1	-X1 -X1		SCH	20.04.2011		
22	terminal connection diagram Anschlussplan		2	-X2 -X2		SCH	20.04.2011		
23	terminal connection diagram Anschlussplan		3	-X2 -X2		SCH	20.04.2011		
24	terminal connection diagram Anschlussplan		4	-X3 -X3		SCH	20.04.2011		
25	terminal connection diagram Anschlussplan		5	-X4 -X4		SCH	20.04.2011		
26	Layout diagram Aufbauplan		1			SCH	20.04.2011		

comments :

iteration	date	user	name	date	revision	Norm	origin	supersedeure for	supersedeure with
	20.04.2011	SCH							
<p>RIEDEL PRECISION IN COOLING</p>									
<p>directory 1</p>									
								97838	page 1
								2	page 2

directory · Inhaltsverzeichnis

Nº	planning type Planart	2nd designation layer 2. Bezeichnungsebene	page Blatt	page-designation Blattbenennung	special notes Sondervermerke	user Bearbeiter	date Datum	revision Revision	date Datum
27	item list Geräte-Stückliste		1			SCH	20.04.2011		
28	item list Geräte-Stückliste		2			SCH	20.04.2011		
29	cable list Kabelliste		1			SCH	20.04.2011		

comments :

R. alteration		date	name	reviewed	Norm	origin	supersede for	supersedeure with	directory	97838	page 2
		20.04.2011							2		2
											pa.



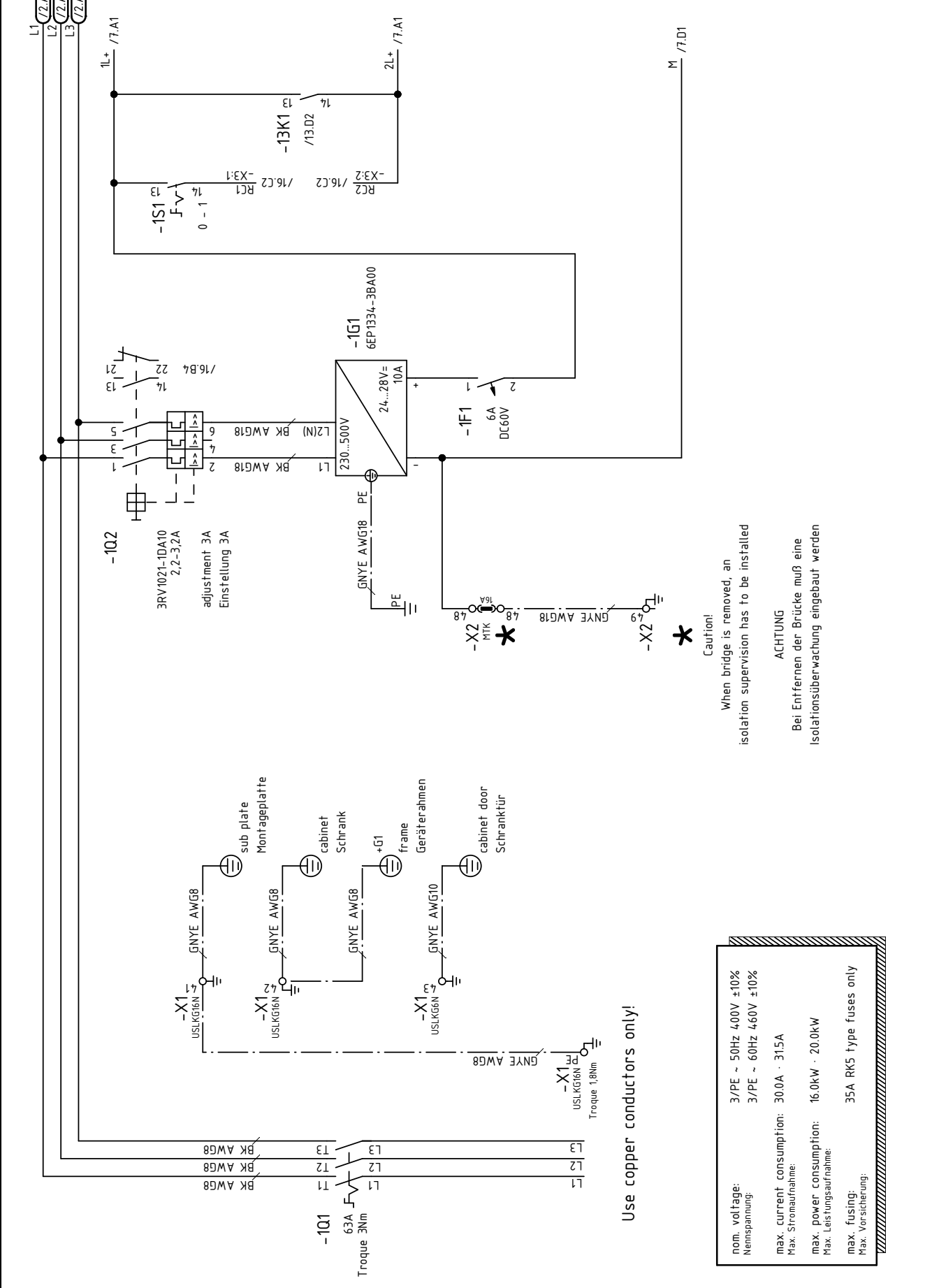

Use copper conductors only!

nom. voltage: Nennspannung:	3/PE ~ 50Hz 400V ±10%
max. current consumption: Max. Stromaufnahme:	3/PE ~ 60Hz 460V ±10%
max. power consumption: Max. Leistungsaufnahme:	30.0A · 31.5A
max. fusing: Max. Vorsicherung:	16.0kW · 20.0kW
	35A RK5 type fuses only

Caution!
When bridge is removed, an isolation supervision has to be installed

ACHTUNG
Bei Entfernen der Brücke muß eine Isolationsüberwachung eingebaut werden

technical alterations reserved!

protective note DIN 34 / DIN ISO 16016

drawn with ELCAD/AUCPLAN (R) 7.0 SP4

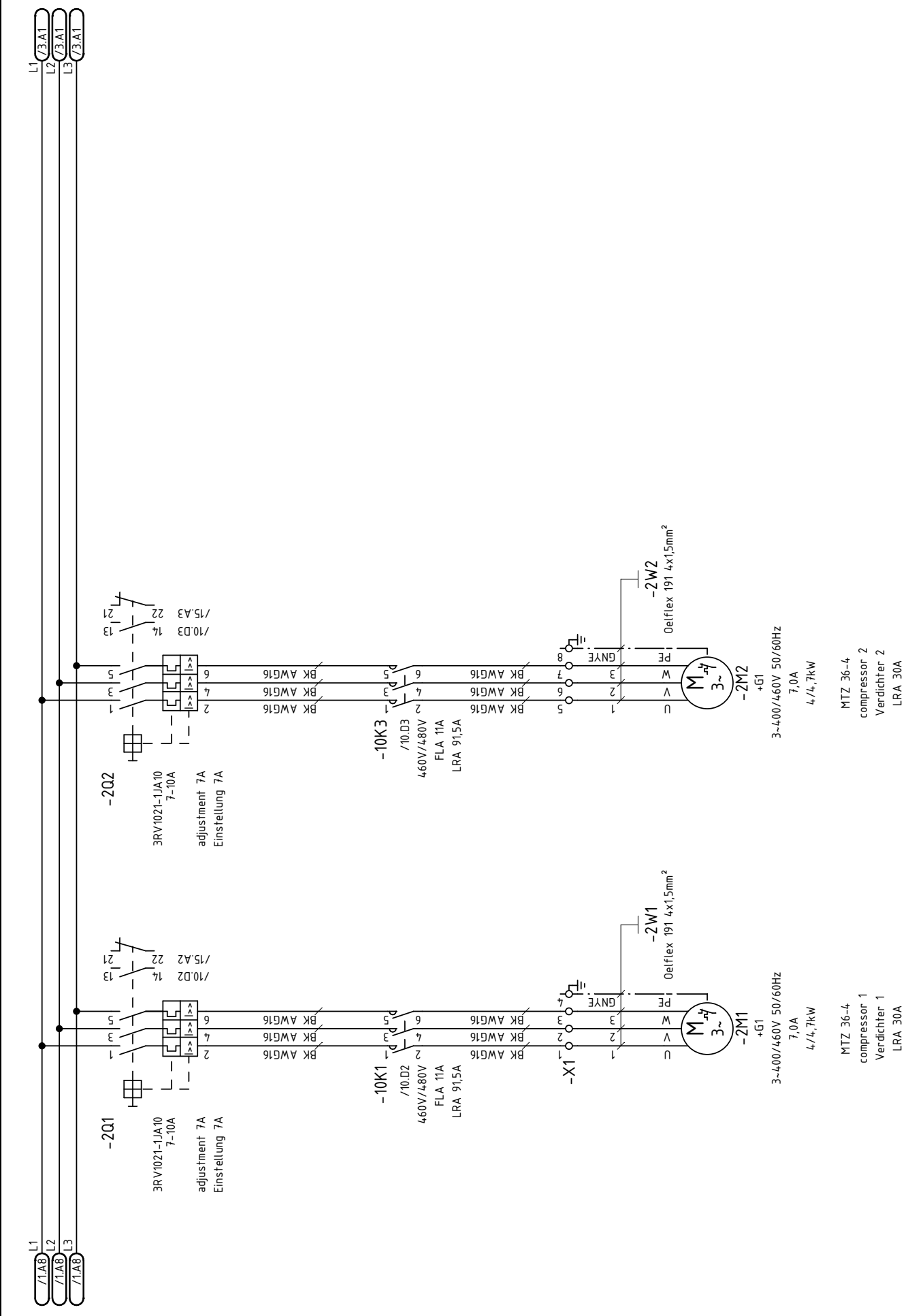

date	20.04.2011
user	SCH
reviewed	
name	norm
date	
name	norm
origin	

supersede for



circuit diagram
2
load circuit compressor

technical alterations reserved!

protective note DIN 34 / DIN ISO 16016

drawn with ELCAD/AUCOPLAN (R) 7.0 SP4

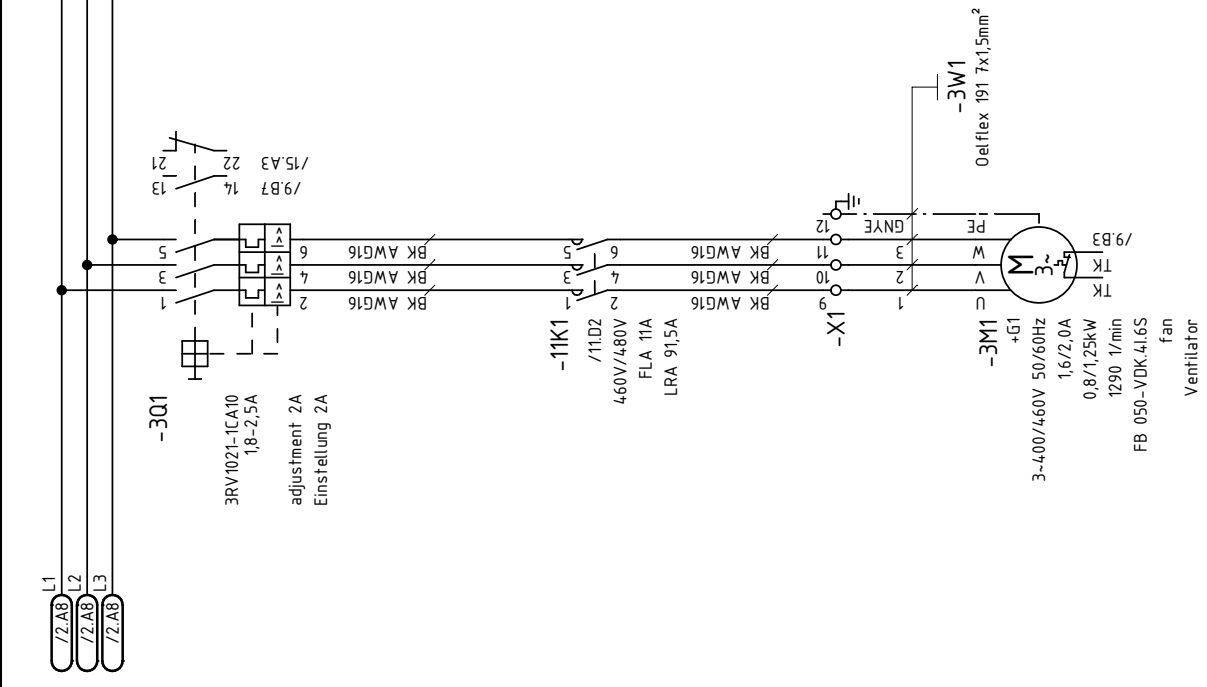

alteration	date	name	norm	origin	supersede for

date	20.04.2011
user	SCB
reviewed	
name	
norm	



PRECISION IN COOLING
supersede with

circuit diagram
load circuit condenser-fans

continuation sheet
2 <> 4

page 3

97838

16 pp.

continuation sheet
2 <> 4

page 3

97838

16 pp.

drawn with ELCAD/AUCOPLAN (R) 7.0 SP4
 all wires without cross-section designation are H05V-K-D-BU 1mm²
 protective note DIN 34 / DIN ISO 16016
 technical alterations reserved!

L1 /3 AB
 L2 /3 AB
 L3 /3 AB

L1 /5 A1
 L2 /5 A1
 L3 /5 A1

alteration	date	name	norm	reviewed	user	date
					SCH	20.04.2011

supersedure for
 supersedure with



PRECISION IN COOLING

circuit diagram
 4

reserve

continuation sheet
 3 « » 5
 page 4
 16 pp.

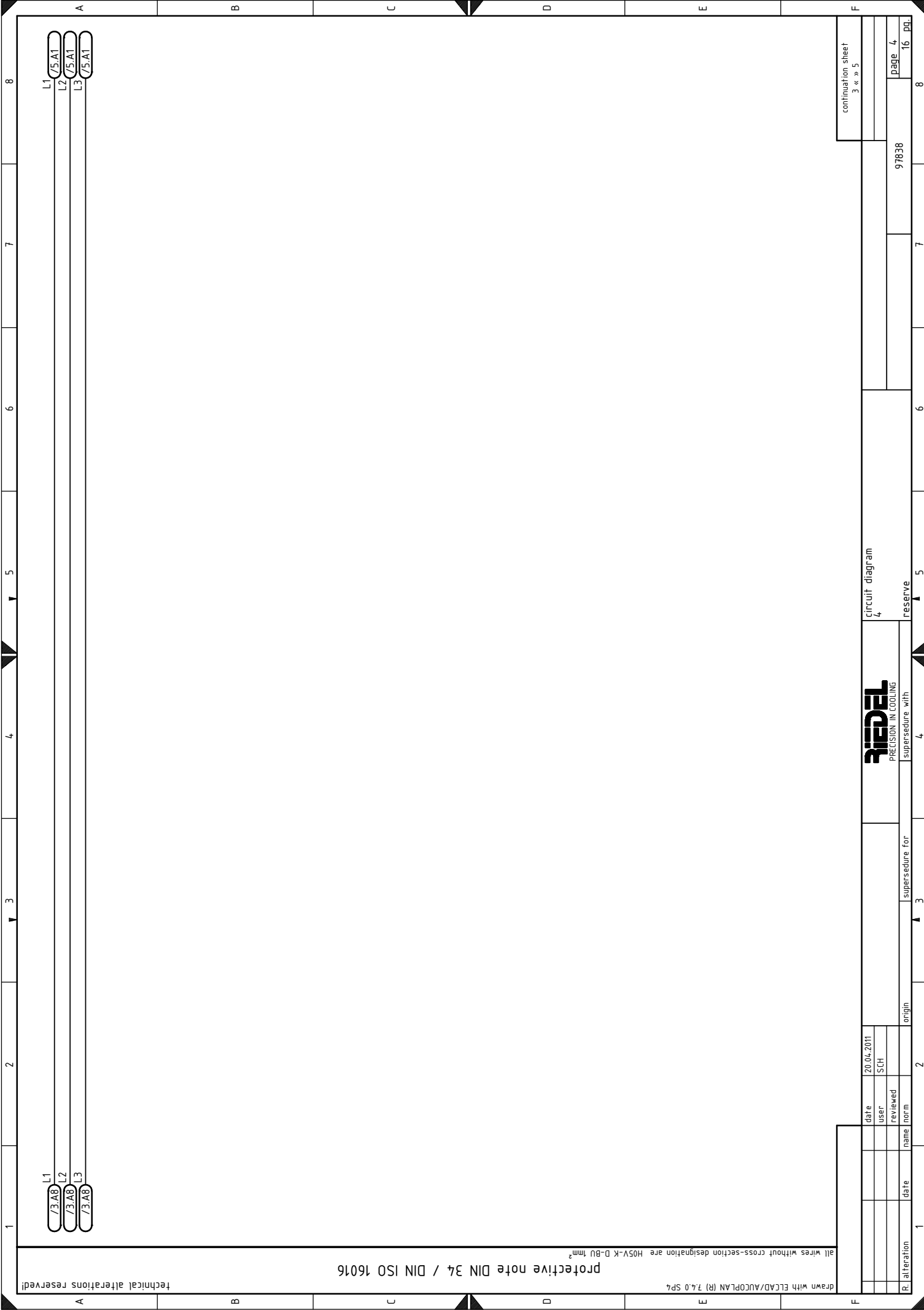

technical alterations reserved!

protective note DIN 34 / DIN ISO 16016

Drawn with ELCAD/AUCPLAN (R) 7.0 SP4

all wires without cross-section designation are H05V-K-D-BU 1mm²

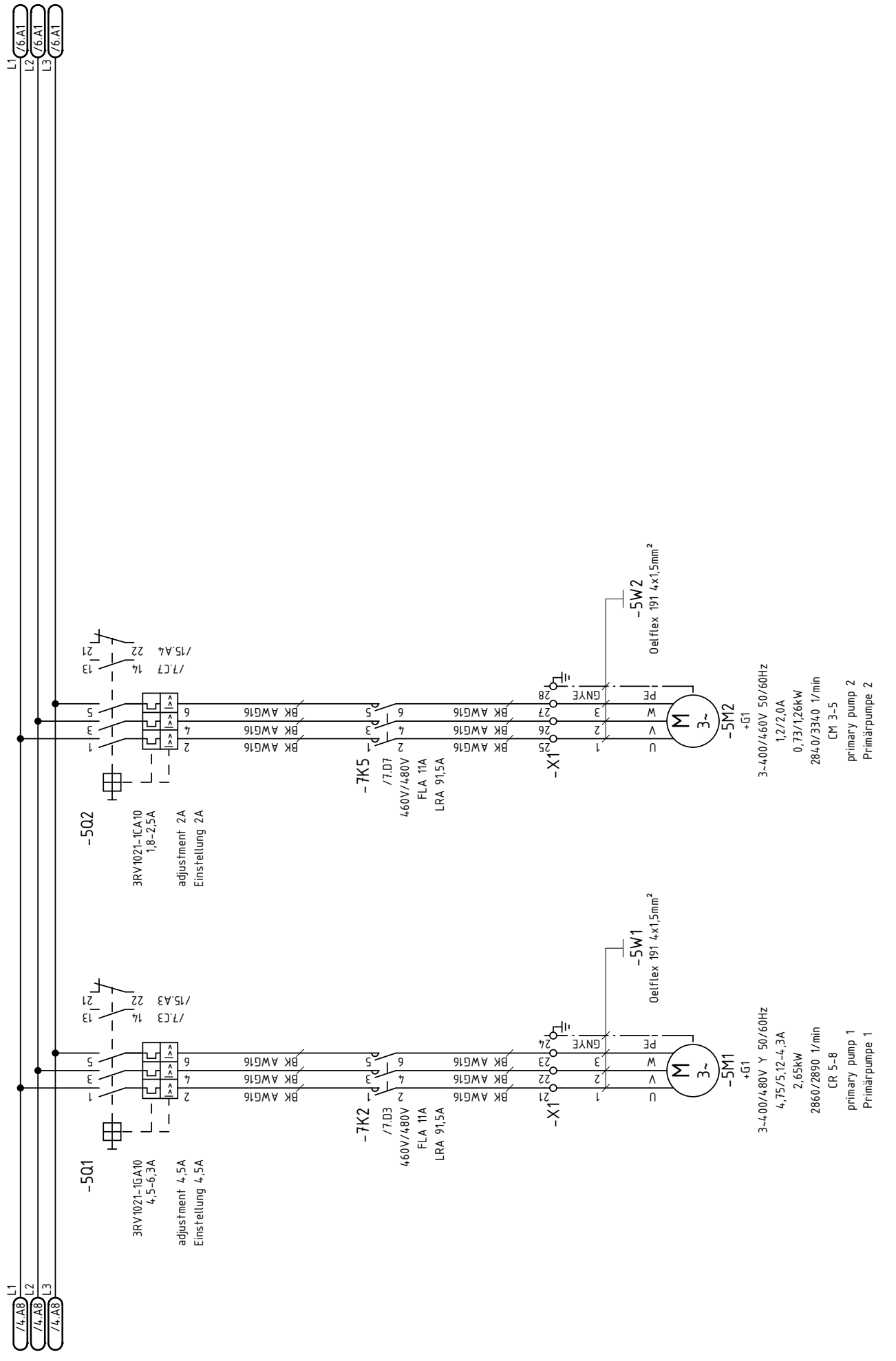

R.	alteration	date	name	norm	reviewed	user	date	20.04.2011
						SCH		

supersede for			origin
supersede with			3

PRECISION IN COOLING	
RIEDEL	

5	circuit diagram
5	load circuit pumps

97838	page 5
16	pp.

continuation sheet
4 << >> 6

technical alterations reserved!

protective note DIN 34 / DIN ISO 16016

Drawn with ELCAD/AUCPLAN (R) 7.0 SP4

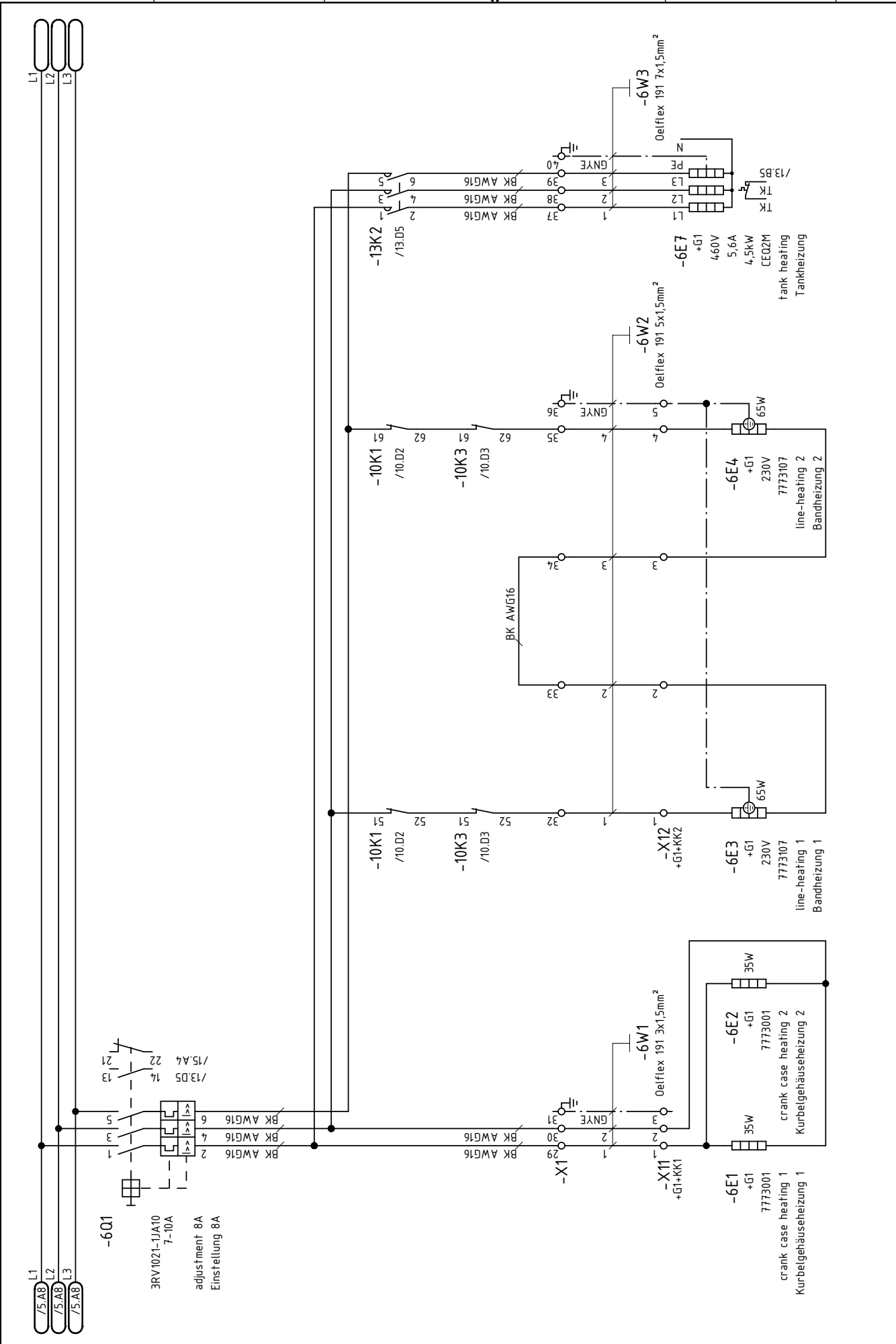

date		20.04.2011		user		SCH		reviewed		name		norm		origin		supersedeure for		supersedeure with		load circuit heatings		97838		page 6		16 pp.									
R. alteration		date		name		norm		reviewed		user		date		20.04.2011		SCH		name		norm		origin		supersedeure for		supersedeure with		load circuit heatings		97838		page 6		16 pp.	

continuation sheet 5 <> 7



circuit diagram
6
load circuit heatings

PRECISION IN COOLING
supersedeure with

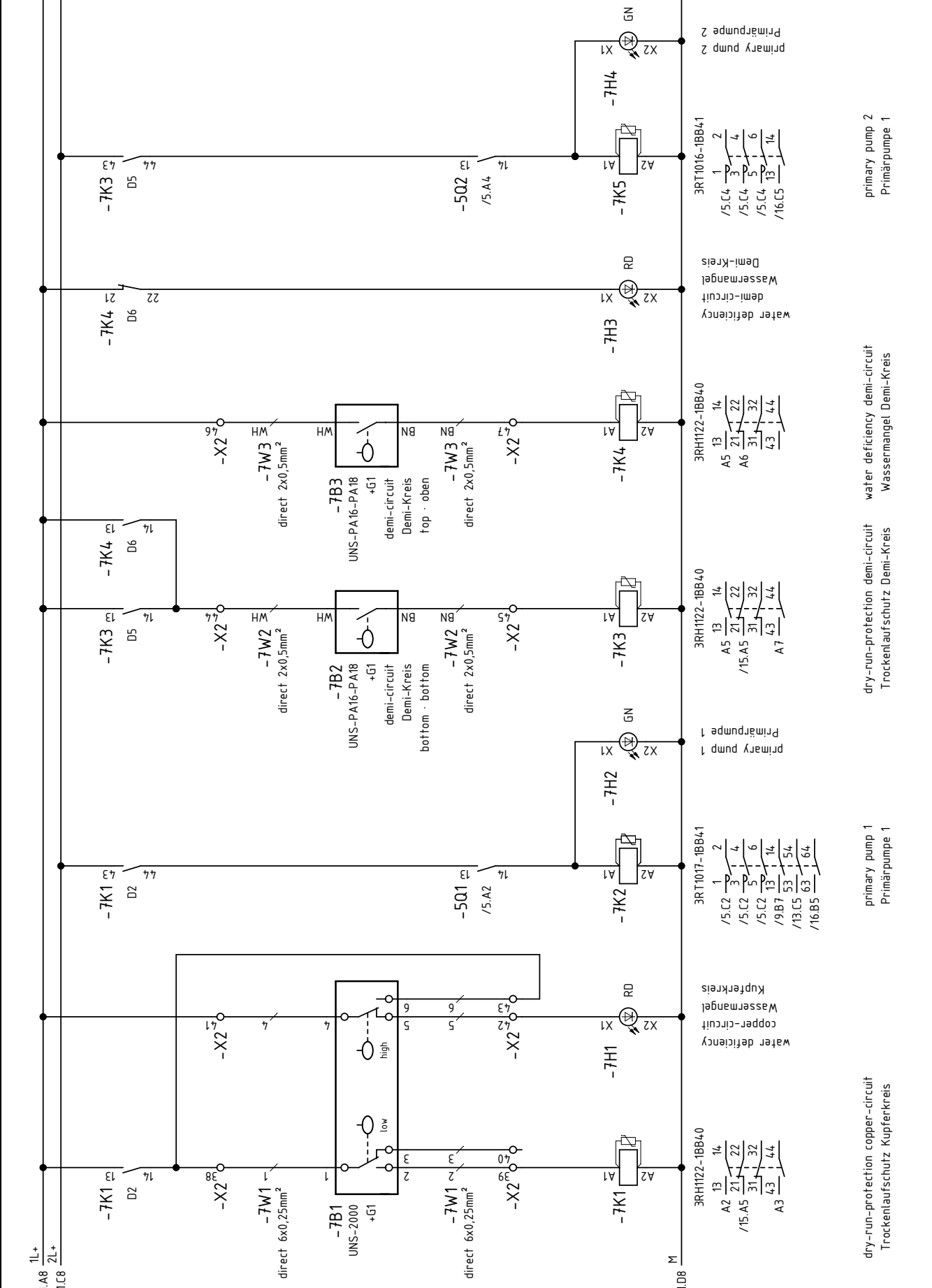

dry-run-protection copper-circuit
Trockenlaufschutz Kupferkreis

primary pump 1
Primärpumpe 1

dry-run-protection demi-circuit
Trockenlaufschutz Demi-Kreis

primary pump 2
Primärpumpe 1

date	20.04.2011
user	SCH
reviewed	
name	supersedure for
date	
name	supersedure with
norm	
origin	

circuit diagram	
control circuit pump-control	

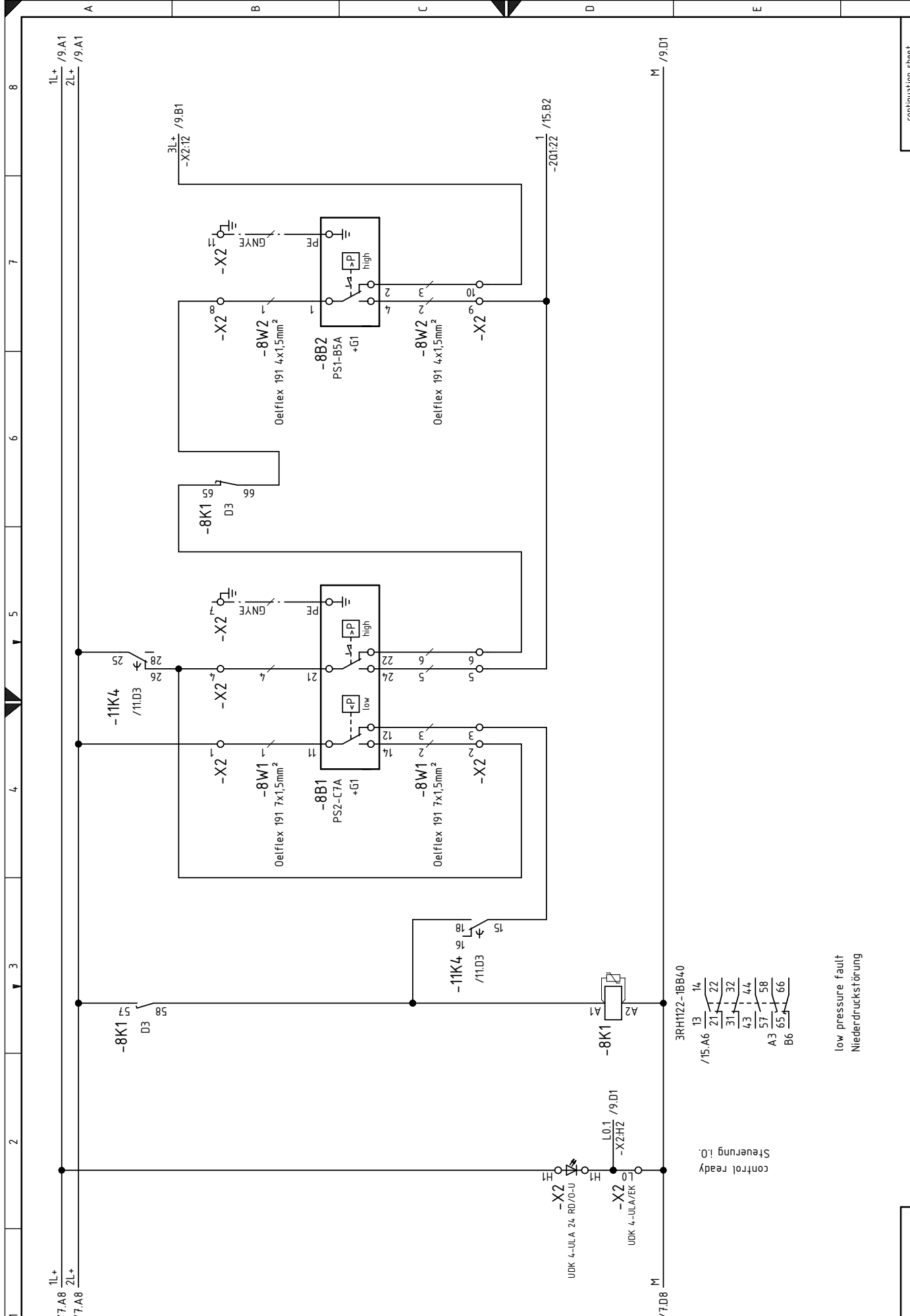

R. alteration	date	name	norm	origin	supersede for

date	20.04.2011
user	SCH
reviewed	
name	
norm	
origin	
supersede for	

supersedeure with

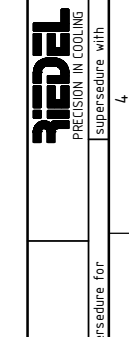

circuit diagram 8
control circuit pressostats

control ready i.O.
Steuerung i.O.

3RH122-1BB40
/15.A6 13 14
21 22
31 32
43 44
A3 57 58
B6 65 66

low pressure fault
Niederdruckstörung

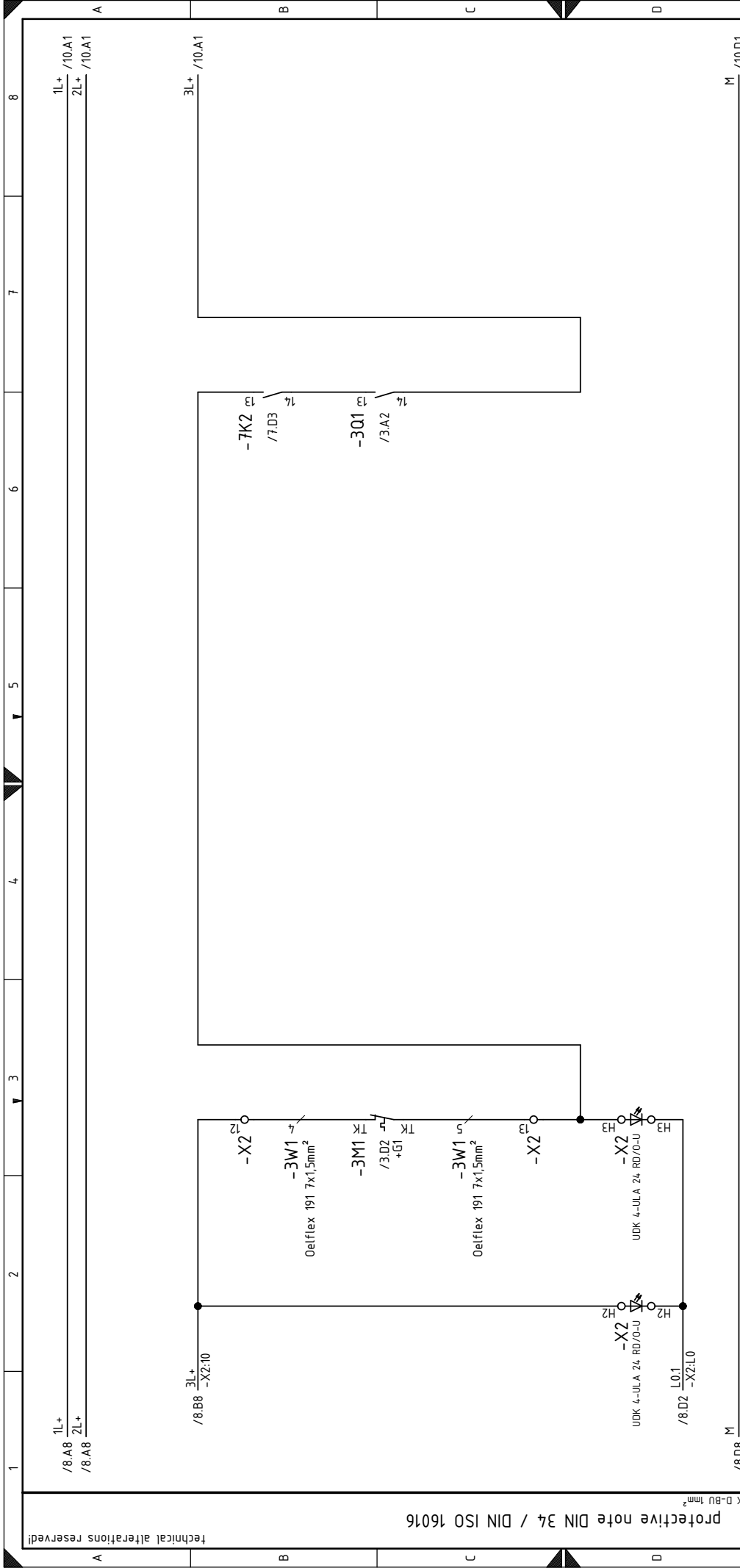

technical alterations reserved!
 protective note DIN 34 / DIN ISO 16016
 drawn with ELCAD/AUCOPLAN (R) 7.0 SP4
 all wires without cross-section designation are HO5V-K-D-BU 1mm²

date		20.04.2011		origin		supersedeure for		supersedeure with		control circuit thermorelays		97838		page 9		16 pp.		continuation sheet		8 « » 10	
user		SCH		name		norm		reviewed		revised		user		SCH		97838		97838		97838	
R. alteration		date		name		norm		reviewed		revised		user		SCH		97838		97838		97838	



PRECISION IN COOLING

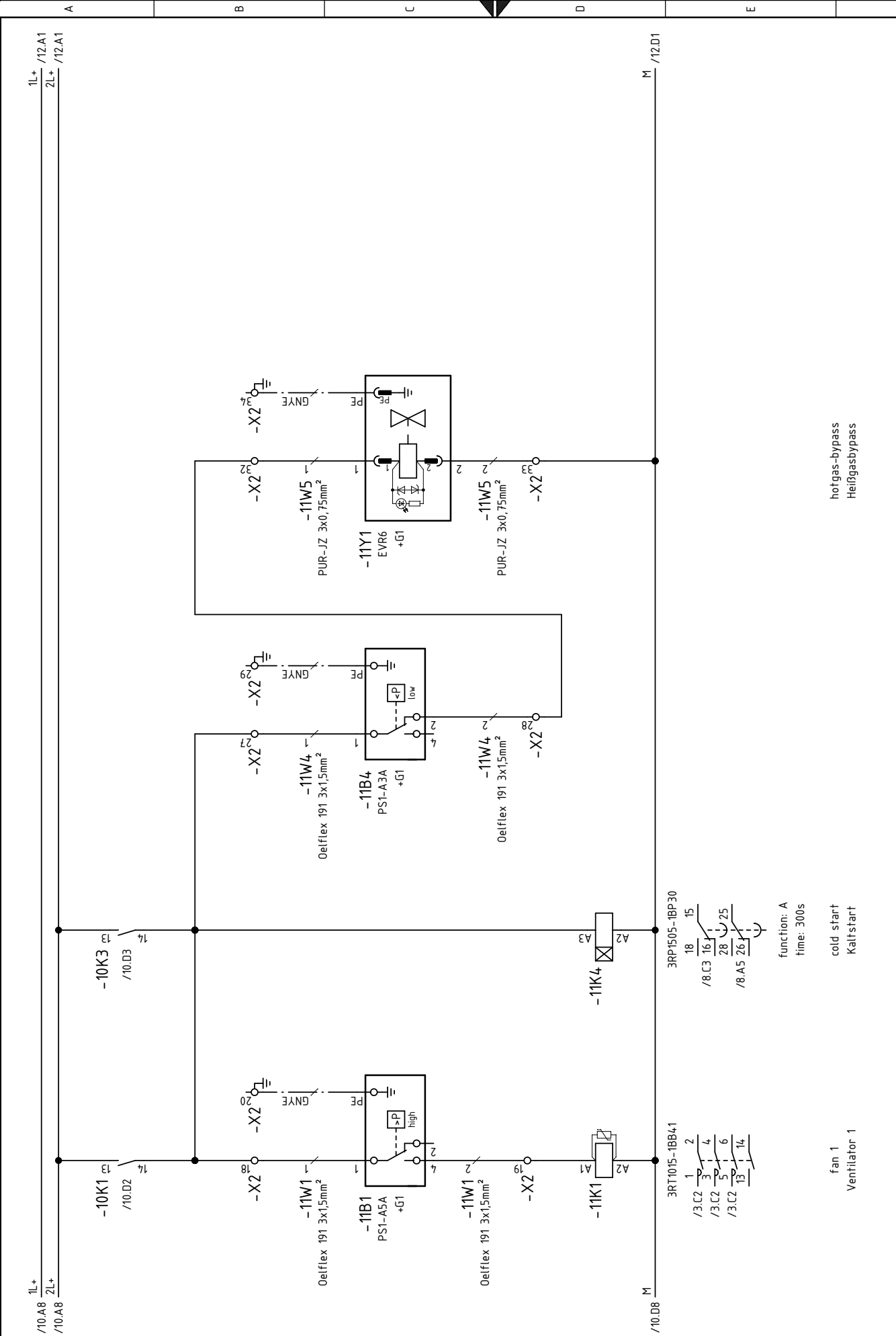

fan 1
Ventilator 1

function: A
time: 300s

cold start
Kaltstart

date		20.04.2011		origin		supersedure for		supersedure with		control circuit fan-control		97838		page 11		16 pp.		continuation sheet		10 < > 12	
user		SCH		name		norm		supersedure with		control circuit fan-control		97838		page 11		16 pp.		continuation sheet		10 < > 12	
R. alteration		date		name		norm		supersedure with		control circuit fan-control		97838		page 11		16 pp.		continuation sheet		10 < > 12	



circuit diagram
11

control circuit fan-control

97838

page 11

16 pp.

technical alterations reserved!

protective note DIN 34 / DIN ISO 16016

drawn with ELCAD/AUCOPLAN (R) 7.0 SP4

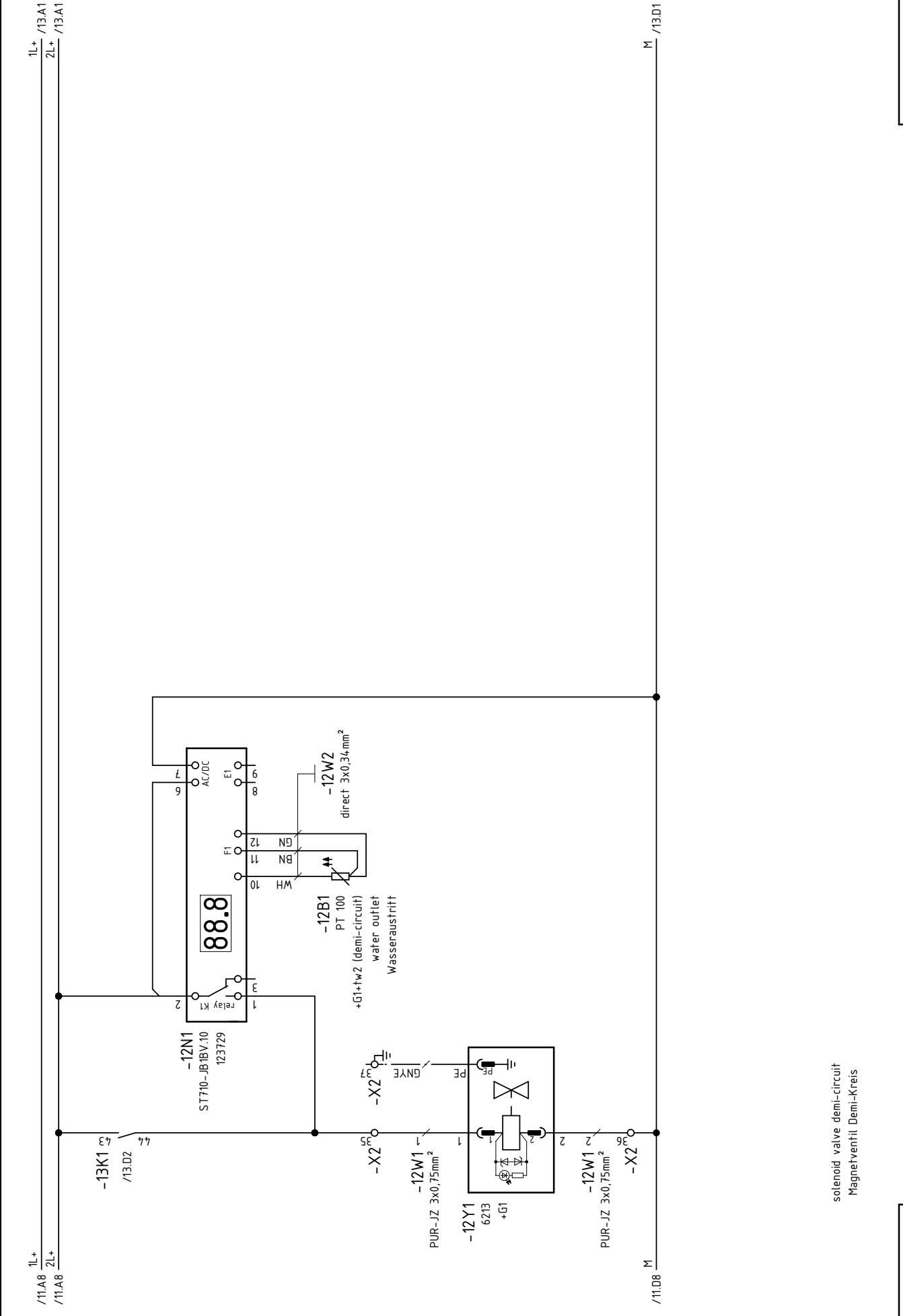

solenoid valve demi-circuit
Magnetventil Demi-Kreis

alteration	date	name	norm	reviewed	user	date
					SCH	20.04.2011

supersede for		supersede with	
origin	3	supersede for	4



PRECISION IN COOLING

circuit diagram
12
control circuit control demi-circuit

97838	page 12
16 pp.	

continuation sheet
11 < » 13

1 2 3 4 5 6 7 8

A B C D E F

M /13.D1

M /11.D8

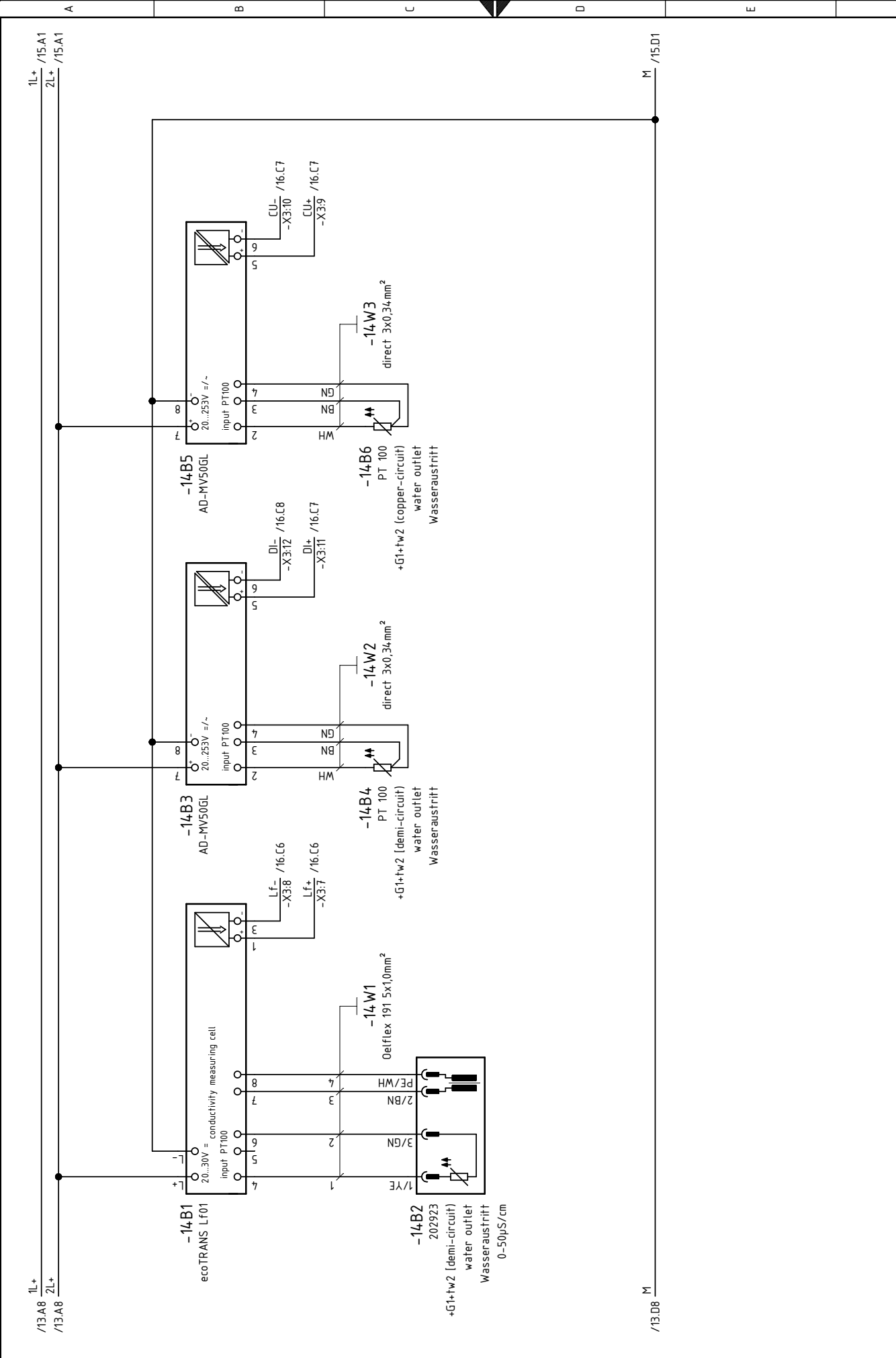

date		20.04.2011		origin		supersedeure for		supersedeure with		control circuit transducer		97838		page 14		16 pp.	
user		SCH		name		norm		PRECISION IN COOLING		Riedel		97838		14		16	
reviewed				date		date		supersedeure with		control circuit transducer		97838		page 14		16 pp.	
R. alteration				name		norm		PRECISION IN COOLING		Riedel		97838		page 14		16 pp.	

technical alterations reserved!

protective note DIN 34 / DIN ISO 16016

drawn with ELCAD/AUCOPLAN (R) 7.0 SP4

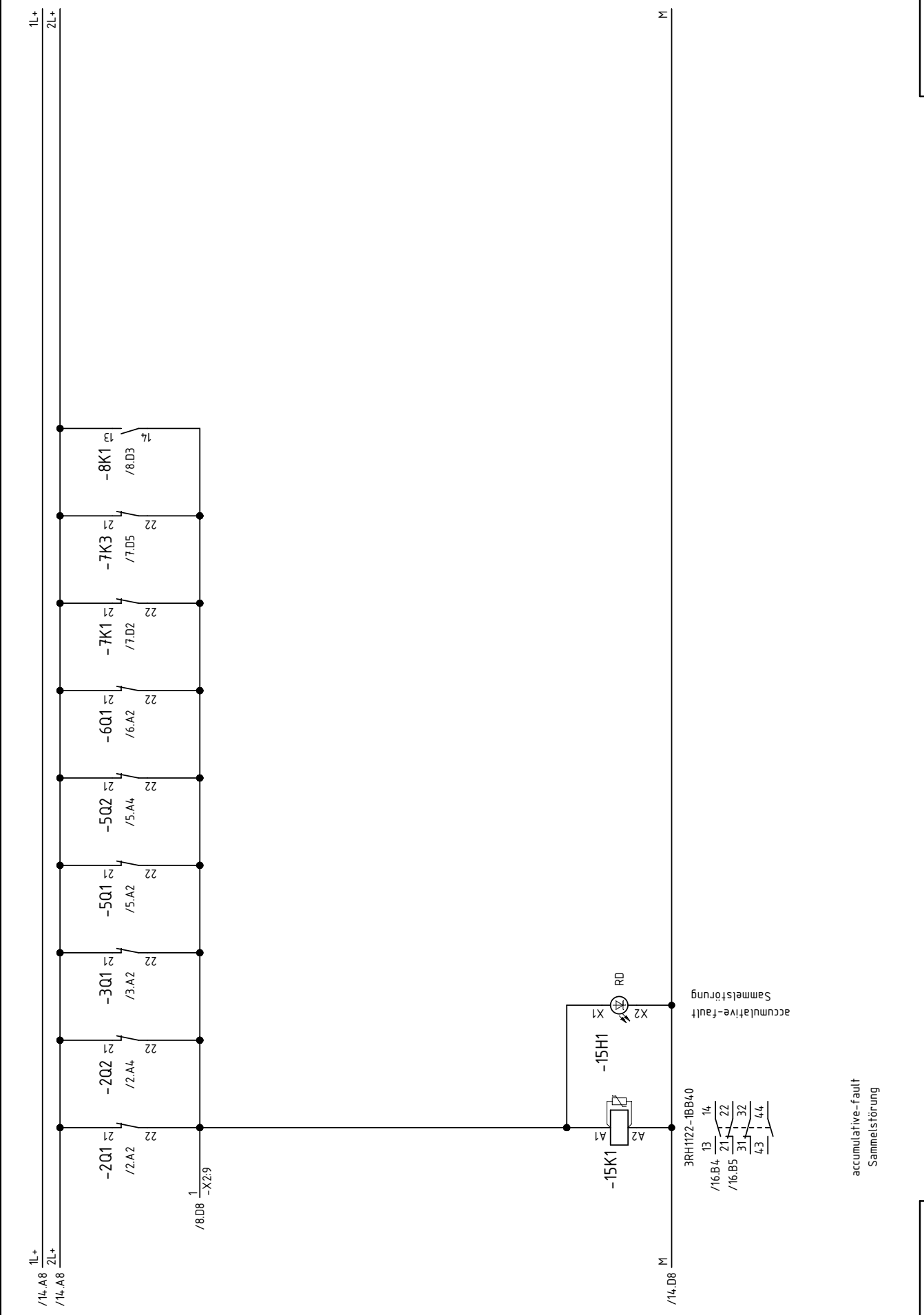

date	20.04.2011
user	SCH
reviewed	
name	norm
date	
alteration	

supersede for	
supersede with	
origin	

RIEDEL
PRECISION IN COOLING

circuit diagram
15
control circuit accumulative-fault

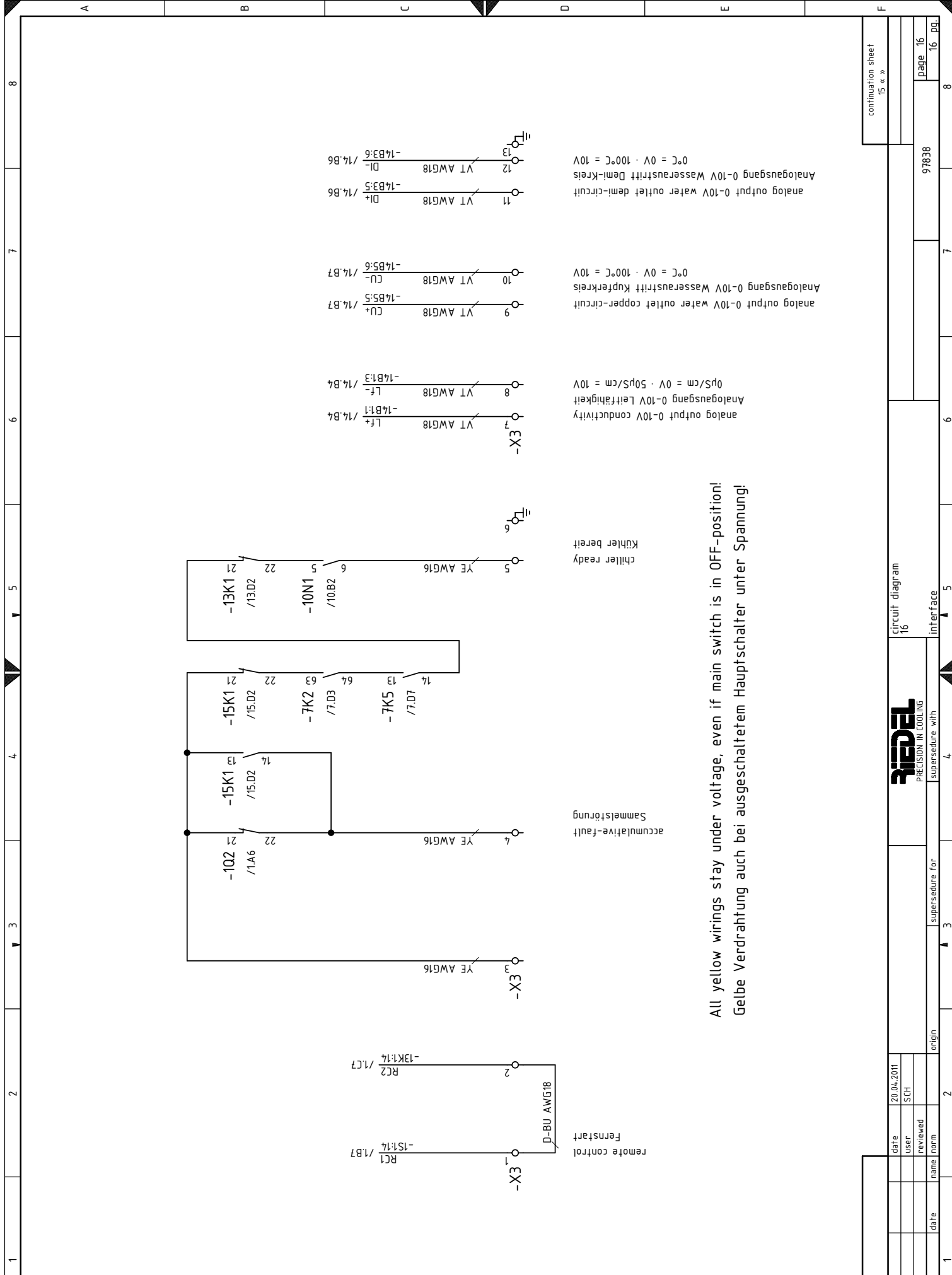

All yellow wirings stay under voltage, even if main switch is in OFF-position!
 Gelbe Verdrahtung auch bei ausgeschaltetem Hauptschalter unter Spannung!

date		20.04.2011		date		20.04.2011	
user		SCH		user		SCH	
reviewed				reviewed			
name		norm		name		norm	
date				date			
P. alteration		supersede for		P. alteration		supersede for	
origin		supersede with		origin		supersede with	
interface		PRECISION IN COOLING		interface		PRECISION IN COOLING	
16		16		16		16	
97838		97838		97838		97838	
page		16		page		16	
16		16		16		16	
pp.		pp.		pp.		pp.	
15		15		15		15	
«		«		«		«	
»		»		»		»	
continuation sheet		continuation sheet		continuation sheet		continuation sheet	

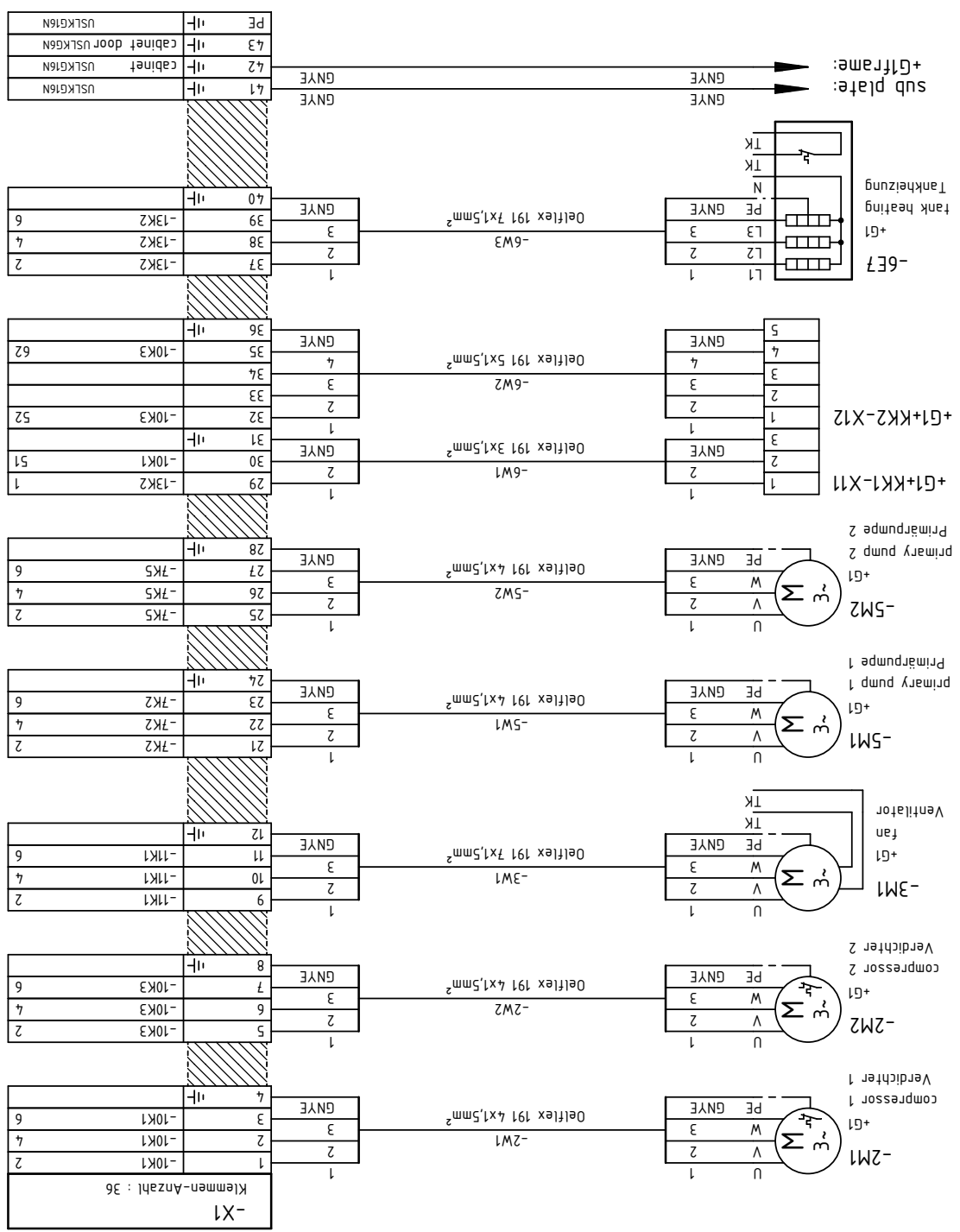



supersedure for

date	20.04.2011	date	
user	SCB	name	
reviewed		norm	
origin		date	
alteration			

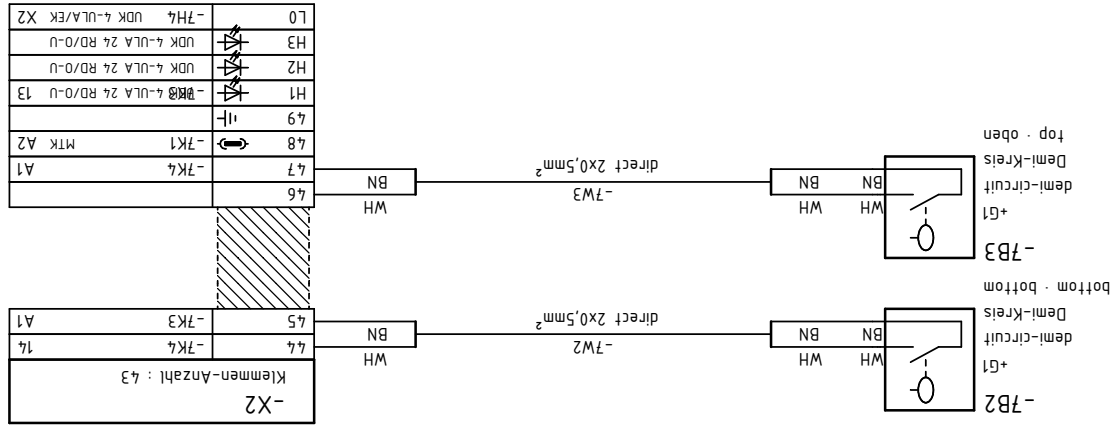

L0	-7H4	UDK 4-ULA/EK X2
H3	-7H3	UDK 4-ULA 24 RD/0-U
H2	-7H2	UDK 4-ULA 24 RD/0-U
H1	-7H1	UDK 4-ULA 24 RD/0-U 13
49	-7H0	UDK 4-ULA 24 RD/0-U
48	-7K1	MTK A2
47	-7K4	A1
46		

44	-7K4	A1
45	-7K3	A1
Klemmen-Anzahl : 43		
-X2		

-X3		Klemmen-Anzahl : 13	
1	-1S1	14	
2	-13K1	14	
3	-10Z	21	
4	-10Z	22	
5	-10N1	6	
6		6	
7	-14B1	1	
8	-14B1	3	
9	-14B5	5	
10	-14B5	6	
11	-14B3	5	
12	-14B3	6	
13		13	

R. alteration		date		name		reviewed		date		user		SCH		20.04.2011		origin		supersedure for		supersedure with		PRECISION IN COOLING		RIEDEL		terminal connection diagram		4		97838		page 4		5		pp.	
P.		date		name		reviewed		date		user		SCH		20.04.2011		origin		supersedure for		supersedure with		PRECISION IN COOLING		RIEDEL		terminal connection diagram		4		97838		page 4		5		pp.	

-X4		Klemmen-Anzahl : 3	
1	-13B1	2	
2	-14B5	3	

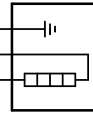

-13E1
cabinet heating
Schaltschrankheizung

alteration	date	name	norm	reviewed	user	date	20.04.2011	SCH	origin	supersedure for	supersedure with	terminal connection diagram	97838	+	5	page 5	5	pp.
R.																		



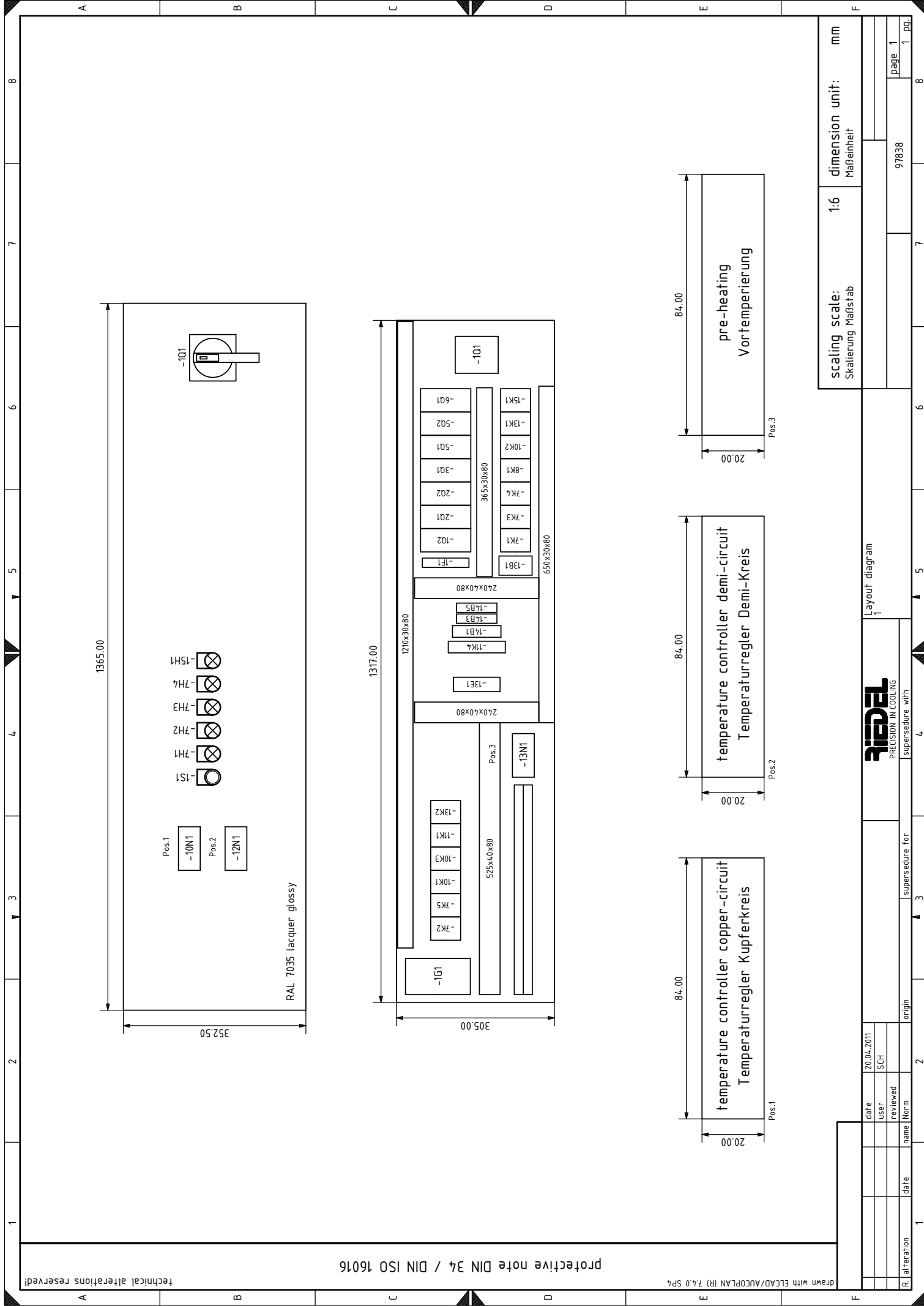

scaling scale:	1:6	dimension unit:	mm
Skalierung Maßstab		Maßeinheit	
97838		page 1	1 pp.

date		20.04.2011		Layout diagram	
user		SCH		1	
reviewed				PRECISION IN COOLING	
name		supersedure for		supersedure with	
date		origin		4	
name		supersedure for		supersedure with	
date		origin		4	
name		supersedure for		supersedure with	
date		origin		4	

devices-parts-list · Geräte-Stückliste

No	item Betriebsmittel	quantity Menge	identifier Bezeichnung	type Typ	part number Artikelnummer	No	item Betriebsmittel	quantity Menge	identifier Bezeichnung	type Typ	part number Artikelnummer
1	-1F1	1	miniature circuit breaker Leistungsschutzschalter	5SY4106-6	451804.50.11	27	-7H3	1	pilot light Leuchtmelder	3SB3244-6AA20	451803.52.61
2	-1G1	1	power supply unit single phase Kompaktnetzgerät 1-phasig	6EP1334-3BA00	451804.49.12	28	-7H3	1	plate holder Schliffträger	3SB3923-0AV	451803.54.39
3	-1O1	1	main/emergency stop-switch Haupt/NOT-AUS-Schalter	3LD2514-0TK53	451803.57.72	29	-7H3	1	legend plate Bezeichnungsschild	3SB1906-2AA	451803.54.40
4	-1O2	1	circuit breaker Leistungsschalter	3RV1021-1DA10	451801.46.50	30	-7H4	1	pilot light Leuchtmelder	3SB3244-6AA40	451803.52.62
5	-1O2	1	auxiliary contact Hilfsschalter	3RV1901-1E	451803.45.90	31	-7H4	1	plate holder Schliffträger	3SB3923-0AV	451803.54.39
6	-1S1	1	selector switch Steuerschalter	3SB3202-2KA11	451803.50.18	32	-7H4	1	legend plate Bezeichnungsschild	3SB1906-2AA	451803.54.40
7	-1S1	1	plate holder Schliffträger	3SB3923-0AV	451803.54.39	33	-7K1	1	contactor Schutz	3RH1122-1BB40	451803.46.55
8	-1S1	1	legend plate Bezeichnungsschild	3SB1906-2AA	451803.54.40	34	-7K1	1	surge suppressor Entstörmodul	3RT1916-1BB00	454102.4.109
9	-2O1	1	circuit breaker Leistungsschalter	3RV1021-1JA10	451801.45.33	35	-7K2	1	contactor Schutz	3RT1017-1BB41	451801.45.15
10	-2O1	1	auxiliary contact Hilfsschalter	3RV1901-1E	451803.45.90	36	-7K2	1	auxiliary contact Hilfsschalter	3RH1911-1FA20	451803.57.66
11	-2O2	1	circuit breaker Leistungsschalter	3RV1021-1JA10	451801.45.33	37	-7K2	1	surge suppressor Entstörmodul	3RT1916-1BB00	454102.4.109
12	-2O2	1	auxiliary contact Hilfsschalter	3RV1901-1E	451803.45.90	38	-7K3	1	contactor Schutz	3RH1122-1BB40	451803.46.55
13	-3O1	1	circuit breaker Leistungsschalter	3RV1021-1CA10	454507.4.1.03	39	-7K3	1	surge suppressor Entstörmodul	3RT1916-1BB00	454102.4.109
14	-3O1	1	auxiliary contact Hilfsschalter	3RV1901-1E	451803.45.90	40	-7K4	1	contactor Schutz	3RH1122-1BB40	451803.46.55
15	-5O1	1	circuit breaker Leistungsschalter	3RV1021-1GA10	454507.4.1.04	41	-7K4	1	surge suppressor Entstörmodul	3RT1916-1BB00	454102.4.109
16	-5O1	1	auxiliary contact Hilfsschalter	3RV1901-1E	451803.45.90	42	-7K5	1	contactor Schutz	3RT1016-1BB41	451801.44.44
17	-5O2	1	circuit breaker Leistungsschalter	3RV1021-1CA10	454507.4.1.03	43	-7K5	1	surge suppressor Entstörmodul	3RT1916-1BB00	454102.4.109
18	-5O2	1	auxiliary contact Hilfsschalter	3RV1901-1E	451803.45.90	44	-8K1	1	contactor Schutz	3RH1122-1BB40	451803.46.55
19	-6O1	1	circuit breaker Leistungsschalter	3RV1021-1JA10	451801.45.33	45	-8K1	1	contactor Schutz	3RH1122-1BB40	3RH1911-1FB11
20	-6O1	1	auxiliary contact Leistungsschalter	3RV1901-1E	451803.45.90	46	-8K1	1	surge suppressor Entstörmodul	3RT1916-1BB00	454102.4.109
21	-7H1	1	pilot light Leuchtmelder	3SB3244-6AA20	451803.52.61	47	+G1-Tank	1	temperature probe Temperaturfühler	KTY 81-121	451804.4.2.86
22	-7H1	1	plate holder Schliffträger	3SB3923-0AV	451803.54.39	48	-10K1	1	contactor Schutz	3RT1017-1BB41	451801.45.15
23	-7H1	1	legend plate Bezeichnungsschild	3SB1906-2AA	451803.54.40	49	-10K1	1	auxiliary contact Hilfsschalter	3RH1911-1FA02	
24	-7H2	1	pilot light Leuchtmelder	3SB3244-6AA40	451803.52.62	50	-10K1	1	surge suppressor Entstörmodul	3RT1916-1BB00	454102.4.109
25	-7H2	1	plate holder Schliffträger	3SB3923-0AV	451803.54.39	51	-10K3	1	contactor Schutz	3RT1017-1BB41	451801.45.15
26	-7H2	1	legend plate Bezeichnungsschild	3SB1906-2AA	451803.54.40	52	-10K3	1	auxiliary contact Hilfsschalter	3RH1911-1FA02	

comments :

date	20.04.2011	Item list	97838	page 1
user	SCB			2
name	supersedure for	supersedure with		
name	supersedure for	supersedure with		
date		origin		
date		supersedure for		
date		supersedure with		



PRECISION IN COOLING

devices-parts-list · Geräte-Stückliste

No	item Betriebsmittel	quantity Menge	identifier Bezeichnung	type Typ	part number Artikelnummer	item Betriebsmittel	quantity Menge	identifier Bezeichnung	type Typ	part number Artikelnummer
53	-10K3	1	surge supressor Entstörmodul	3RT1916-1BB00	4.54102.4.109	-15K1	1	surge supressor Entstörmodul	3RT1916-1BB00	4.54102.4.109
54	-10N1	1	thermostat Thermostatregler	ST710-KHJV.16	4.51803.59.37					
55	-11K1	1	contactor Schütz	3RT1015-1BB41	4.51801.44.43					
56	-11K1	1	surge supressor Entstörmodul	3RT1916-1BB00	4.54102.4.109					
57	-11K4	1	electronic timing relay Elektronisches Zeitrelais	3RP1505-1BP30	4.51803.57.75					
58	+G1+Iw2 (demi-circuit)-12B1		temperature probe Temperaturfühler	PT 100	4.51801.42.02					
59	-12N1	1	thermostat Thermostatregler	ST710-JB1BV.10	4.51815.41.90					
60	+G1+Iank-13B1	1	temperature probe Temperaturfühler	PT 100	4.51801.42.02					
61	-13B1	1	thermostat Thermostatregler	TRO 60	4.51804.48.96					
62	-13E1	1	PTC-cabinet-heating PTC-Konvektionshheizgerät	SH30						
63	-13K1	1	contactor Schütz	3RH1122-1BB40	4.51803.46.55					
64	-13K1	1	auxiliary contact Hilfsschalter	3RH1911-1BA10	4.51803.46.58					
65	-13K1	1	surge supressor Entstörmodul	3RT1916-1BB00	4.54102.4.109					
66	-13K2	1	contactor Schütz	3RT1017-1BB41	4.51801.45.15					
67	-13K2	1	surge supressor Entstörmodul	3RT1916-1BB00	4.54102.4.109					
68	-13N1	1	thermostat Thermostatregler	ST710-JB1BV.10	4.51815.41.90					
69	-14B1	1	signal converter (conductivity) Leitfähigkeitsmessumformer	ecoTRANS Lf01	4.51804.47.55					
70	+G1+Iw2 (demi-circuit)-14B2		conductivity measuring cell Leitfähigkeitsmesszelle	202923	4.51804.47.56					
71	-14B3	1	signal converter (temperature) Temperaturmessumformer	AD-MV50GL	4.51803.58.38					
72	+G1+Iw2 (demi-circuit)-14B4		temperature probe Temperaturfühler	PT 100	4.51801.42.02					
73	-14B5	1	signal converter (temperature) Temperaturmessumformer	AD-MV50GL	4.51803.58.38					
74	+G1+Iw2 (copper-circuit)-14B6		temperature probe Temperaturfühler	PT 100	4.51801.42.02					
75	-15H1	1	pilot light Leuchtmelder	3SB3244-6AAZ0	4.51803.52.61					
76	-15H1	1	plate holder Schildträger	3SB3923-0AV	4.51803.54.39					
77	-15H1	1	legend plate Bezeichnungsschild	3SB1906-2AA	4.51803.54.40					
78	-15K1	1	contactor Schütz	3RH1122-1BB40	4.51803.46.55					

comments :

date	20.04.2011	item list	
user	SCB	2	
revised			
name			
norm			
date			
name			
norm			
origin			
supersedeure for			
supersedeure with			
97838			
page 2			
2			
pa			

cable list · Kabelliste

No	item Betriebsmittel	comment Kommentar	cable-length Kabellänge	cable type Kabelltyp	identifier Bezeichnung	part number Artikelnummer	cable-route location 1 Kabelweg Ort 1	cable-route location 2 Kabelweg Ort 2
1	-2W1	compressor 1 Verdichter 1	4,00m	Oelflex 191 4x1,5mm ²	PVC-control line; number coded PVC-Steuerverleitung; nummeriert			+G1
2	-2W2	compressor 2 Verdichter 2	4,00m	Oelflex 191 4x1,5mm ²	PVC-control line; number coded PVC-Steuerverleitung; nummeriert			+G1
3	-3W1	condenser fan Kondensatorventilator	3,50m	Oelflex 191 7x1,5mm ²	PVC-control line; number coded PVC-Steuerverleitung; nummeriert			+G1
4	-5W1	primary pump 1 Primärpumpe 1	4,00m	Oelflex 191 4x1,5mm ²	PVC-control line; number coded PVC-Steuerverleitung; nummeriert			+G1
5	-5W2	primary pump 2 Primärpumpe 2	4,00m	Oelflex 191 4x1,5mm ²	PVC-control line; number coded PVC-Steuerverleitung; nummeriert			+G1
6	-6W1	crank case heating Kurbelgehäuseheizung	4,00m	Oelflex 191 3x1,5mm ²	PVC-control line; number coded PVC-Steuerverleitung; nummeriert	6006153		+G1+KK1
7	-6W2	crankcase heatings Bandheizungen	4,00m	Oelflex 191 5x1,5mm ²	PVC-control line; number coded PVC-Steuerverleitung; nummeriert			
8	-6W3	tank heating Tankheizung	4,00m	Oelflex 191 7x1,5mm ²	PVC-control line; number coded PVC-Steuerverleitung; nummeriert			+G1
9	-7W1	float switch Schwimmerschalter	2,00m	direct 6x0,25mm ²				+G1
10	-7W2	level switch Niveaurewächter	2,00m	direct 2x0,5mm ²				+G1
11	-7W3	level switch Niveaurewächter	2,00m	direct 2x0,5mm ²				+G1
12	-8W1	h/v1-press.-pressostat HD/ND-Kombi-Pressostat	2,00m	Oelflex 191 7x1,5mm ²	PVC-control line; number coded PVC-Steuerverleitung; nummeriert			+G1
13	-8W2	high-pressure pressostat Hochdruckpressostat	2,00m	Oelflex 191 4x1,5mm ²	PVC-control line; number coded PVC-Steuerverleitung; nummeriert			+G1+Tank (copper-circuit)
14	-10W1	temperature probe Temperaturfühler	4,00m	direct 2x0,34mm ²				+G1
15	-11W1	fan-control pressostat Lüfterpressostat	2,00m	Oelflex 191 3x1,5mm ²	PVC-control line; number coded PVC-Steuerverleitung; nummeriert			+G1
16	-11W4	low-pressure pressostat Niederdruckpressostat	2,00m	Oelflex 191 3x1,5mm ²	PVC-control line; number coded PVC-Steuerverleitung; nummeriert			+G1
17	-11W5	ho/gas-bypass Heißgasbypass	5,00m	PUR-JZ 3x0,75mm ²	connector; Z-Diode UC2AV; LED; UL Ventilstecker; Z-Diode UC2AV; LED; UL	451804,49,44		+G1
18	-12W1	solenoid valve Magnetventil	5,00m	PUR-JZ 3x0,75mm ²	connector; Z-Diode UC2AV; LED; UL Ventilstecker; Z-Diode UC2AV; LED; UL	451804,49,44		+G1
19	-12W2	temperature probe Temperaturfühler	4,00m	direct 3x0,34mm ²				+G1+tw2 (demi-circuit)
20	-13W1	temperature probe Temperaturfühler	4,00m	direct 3x0,34mm ²				+G1+Tank
21	-14W1	measuring cell Messzelle	4,00m	Oelflex 191 5x1,0mm ²	PVC-control line; number coded PVC-Steuerverleitung; nummeriert	6006086		+G1+tw2 (demi-circuit)
22	-14W2	temperature probe Temperaturfühler	4,00m	direct 3x0,34mm ²				+G1+tw2 (demi-circuit)
23	-14W3	temperature probe Temperaturfühler	4,00m	direct 3x0,34mm ²				+G1+tw2 (copper-circuit)

comments :

date		20.04.2011		cable list		page 1	
user		SCH		1		97838	
reviewed				1		1	
name		norm		supersedeure for		pp.	
date		origin		supersedeure with			
R. alteration		date		name		norm	

ST710-KHJV.16	Ident: 351692
Projekt: 2KP0160xx1	
Sollwert: 21°C +/-1K	

Thermostatregler mit 3 Relaisausgängen und sequentiellem Betrieb

Frontansicht

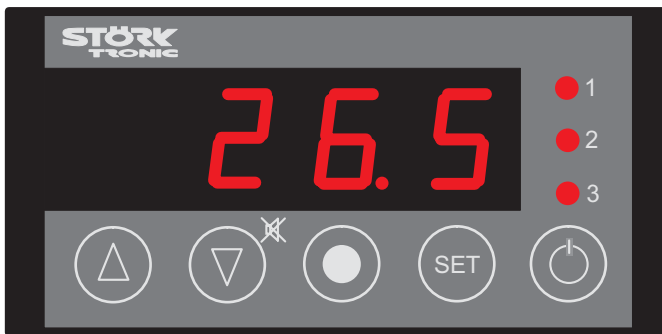

Allgemeine Angaben

Das Gerät ist als Einbauregler im Kleinformat konzipiert und dient zur Temperaturregelung bei hoher Messgenauigkeit. Es ist der Anschluß eines PTC-Temperaturfühlers vorgesehen.

Auf der Frontseite sind eine Folientastatur mit fünf Bedientasten, eine dreistellige Anzeige und drei Leuchtdioden vorhanden. Nach dem Einschalten der Netzspannung weist die Anzeige bei aktivierter Standbyfunktion "AUS" oder andernfalls den aktuellen Istwert aus. Hierbei wird stets der Zustand des Abschaltmoments wieder eingenommen.

Der Anschluß aller Ein- und Ausgänge wird rückseitig über Steck-Klemmleisten vorgenommen. Ein Digitaleingang ermöglicht die Aktivierung eines Nebensollwertes oder das externe Umschalten auf Standby. Als Ausgangsrelais sind drei Schließer vorhanden, von denen zwei für die Regelung vorgesehen sind. Das dritte Relais dient als Alarmkontakt.

Die Einstellung der Sollwerte und Parameter wird in insgesamt drei Bedienebenen vorgenommen. Dabei ist die Einstellung des Hauptsollwertes für jedermann leicht möglich, der Zugriff auf die Parameter jedoch bewußt erschwert, um unbefugte Manipulationen zu vermeiden. Sicherheitsrelevante Einstellungen sind sogar nur über einen besonders verschlüsselten Zugriff erreichbar. Die Vorgehensweise hierzu sollte Endkunden nicht mitgeteilt werden.

Das Gerät erfüllt bei entsprechender Parametrierung die Funktion eines mehrstufigen Temperaturreglers und bietet einige für die Kälteindustrie bestimmte Besonderheiten. Die Regelfunktion läßt sich mit einer Fülle von Möglichkeiten in der Parametrierung auswählen. Eine spezielle Tausch- und Ablösemimik sorgt bei Teillastbetrieb für eine ausgewogene Belastung der angeschlossenen Komponenten. Mindestauszeiten zur Schonung angeschlossener Verdichter können für jeden Ausgang getrennt vorgegeben werden, ferner ist eine gegenseitige Einschaltverzögerung möglich.

Ein in der Parametrierung einstellbares Grenzwertpaar erlaubt einen Temperaturalarm bezogen auf den Regelwert und den Hauptsollwert, wobei Grenzwert- und Bandalarm sowie relative und absolute Grenzwerte wählbar sind. In diesen Alarmfällen läuft die Regelung weiter.

Funktion der Bedientasten



Taste 1: AUF

Durch Drücken dieser Taste wird zum nächsten Parameter gewechselt oder im Verbund mit der SET-Taste der Parameterwert vergrößert.



Taste 2: AB

Durch Drücken dieser Taste wird zum vorhergehenden Parameter gewechselt oder im Verbund mit der SET-Taste der Parameterwert verkleinert. Bei Alarm wird die Summer quittiert.



Taste 3: Universell

Verschiedene Funktionen werden dieser Taste mit Hilfe der Parametrierung zugeordnet, siehe Parameter A83 (Standbyfunktion, Sollwertvorgabe P1, Direktschaltung eines Kontaktes).



Taste 4: SET

Während diese Taste gedrückt ist, wird der Sollwert bzw. der angewählte Parameter angezeigt. Im Verbund mit der Taste AUF oder AB wird der angewählte Parameter verstellt.



Taste 5: Universell

Verschiedene Funktionen werden dieser Taste mit Hilfe der Parametrierung zugeordnet, siehe Parameter A82 (Standbyfunktion, Sollwertvorgabe P1, Direktschaltung eines Kontaktes)

Projekt / project: 2KP0160xx1
Regler / controller: ST710-KHJV.16 (-10N1)
Sollwert / setpoint: 21°C +/-1K
Funktion / function: Betriebsthermostat

Erste Bedienebene

Einstellung der Sollwerte

Der Sollwert ist direkt durch Drücken der SET-Taste anwählbar, unabhängig vom Standby-Mode. Durch zusätzliches Drücken der AUF- oder AB-Taste kann er verstellt werden.

Parameter	Funktionsbeschreibung	Einstellbereich	Standardwert	Kundenwert
S1	Sollwert Regelkontakt 1	P4...P5	0,0 °C	21°C
S1'	Bei A33,,0 und A81=2 bzw. 3: Sollwert bei geschlossenem Eingang E1	-99...+99,9K falls A33=1 P4...P5, falls A33=2	0,0 °C/K	

Der Sollwert für Regelkontakt 2 ist als Parameter P1 nur über die zweite Bedienebene einstellbar.

Zweite Bedienebene

Parameter	Funktionsbeschreibung	Einstellbereich	Standardwert	Kundenwert
P0	Istwert	-----	-----	-----
P1	Sollwert / Delta W Regelkontakt 2	P4...P5, falls A5=0 -99...+99,9 K falls A5=1	10,0 °C/K	0,6K
P2	Hysterese Regelkontakt 1	0,1...99,0 K	1,0 K	1,2K
P3	Hysterese Regelkontakt 2	0,1...99,0 K	1,0 K	1,2K
P4	Sollwertbegrenzung unten	-99 °C...P5	-99 °C	19°C
P5	Sollwertbegrenzung oben	P4...999 °C	999 °C	24°C
P6	Istwertkorrektur	-20,0...+20,0 K	0,0 K	
P19	Tastenverriegelung (Sollwertverstellung gesperrt)	0: Nicht verriegelt 1: Verriegelt	0	
P30	unterer Grenzwert für Alarm	-99...999 °C/K	-99 °C	18°C
P31	oberer Grenzwert für Alarm	-99...999 °C/K	100 °C	25°C
P32	Hysterese Alarm, einseitig	0,1...99,9 K	1,0 K	1K

Dritte Bedienungsebene

Parameter	Funktionsbeschreibung	Einstellbereich	Standardwert	Kundenwert
A1	Schaltsinn Regelkontakt 1	0: Heizkontakt 1: Kühlkontakt	1	
A2	Schaltsinn Regelkontakt 2	0: Heizkontakt 1: Kühlkontakt	1	
A3	Funktion von Regelkontakt 1 bei Fühlerfehler	0: Bei Fehler ab 1: Bei Fehler an	0	
A4	Funktion von Regelkontakt 2 bei Fühlerfehler	0: Bei Fehler ab 1: Bei Fehler an	0	
A5	Auswahl Sollwert / DeltaW Regelkontakt 2	0: Betrieb mit Sollwert 1: Betrieb mit Delta W	1	
A8	Anzeigemodus Istwert (Parameterwerte werden stets mit 0,1 K dargestellt)	0: Ganzzahlig 1: Auflösung 0,5 K 2: Auflösung 0,1 K	1	2
A9	Wichtungsfaktor	0,50...1,50	1,00	
A19	Parameterverriegelung	0: Keine Verriegelung 1: A-Parameter verriegelt 2: A- und P-Parameter verriegelt	0	
A20	Tastenklick	0: Ohne Tastenklick 1: Mit Tastenklick	1	
A30	Funktion Ausgang Alarm	0: Grenzwertalarm, relativ 1: Grenzwertalarm, absolut 2: Bandalarm, relativ 3: Bandalarm, absolut 4: Grenzwertalarm, relativ Alarmkontakt invers 5: Grenzwertalarm, absolut Alarmkontakt invers 6: Bandalarm, relativ Alarmkontakt invers 7: Bandalarm, absolut Alarmkontakt invers	0	3
A31	Sonderfunktion bei Alarm	0: Nicht aktiv 1: Anzeige blinkt 2: Summer aktiv 3: Anzeige blinkt und Summer aktiv 4: wie 3, Summer quittierbar 5: wie 4, nach 10 Min. wiederkehrend 6: wie 4, nach 30 Min. wiederkehrend	0	0
A32	Art der Anzeige	0: Istwertanzeige 1: Sollwertanzeige S1 (S1')	0	
A33	Art von Sollwert S1' (Sollwertabsenkung)	0: Nicht aktivierbar 1: Relativ zu Sollwert S1 2: Absolut (frei einstellbar)	1	0

A34	Zeitbedingte Vertauschung Regelkontakt 1, 2	0: Nicht aktiv 1: Tausch entsprechend A36, A37	0	1
A35	Sequentieller Betrieb Regelkontakt 1, 2	0: Nicht aktiv 1: Stets Wechsel	0	1
A36	Laufzeit vor zeitbedingter Vertauschung	0...999 Sek. bzw. Min.	240 Min.	
A37	Zeiteinheit der Laufzeit A36	0: Sekunden 1: Minuten	1	
A40	Hysteresemodus Regelkontakt 1	0: Symmetrisch 1: Einseitig	1	0
A41	Hysteresemodus Regelkontakt 2	0: Symmetrisch 1: Einseitig	1	0
A50	Mindestaktionszeit Regelkontakt 1 "Ein"	0...600 Sek.	0 Sek.	5 Sek.
A51	Mindestaktionszeit Regelkontakt 1 "Aus"	0...600 Sek.	0 Sek.	120 Sek.
A52	Mindestaktionszeit Regelkontakt 2 "Ein"	0...600 Sek.	0 Sek.	5 Sek.
A53	Mindestaktionszeit Regelkontakt 2 "Aus"	0...600 Sek.	0 Sek.	120 Sek.
A54	Verzögerung nach "Netz-Ein"	0...600 Sek.	0 Sek.	180 Sek.
A55	Gegenseitige Verzögerung Regelkontakt 1, 2	0...600 Sek.	0 Sek.	5 Sek.
A56	Alarmunterdrückung nach "Netz-Ein"	0...240 Min.	0 Min.	5 Sek.
A60	Fühlerauswahl	21: PTC 22: Pt1000 Zweileiteranschluss	21	
A70	Softwarefilter	1: Nicht aktiv Mittelwert über : 2: 2 Messwerte (ca. 0,6 Sek.) 4: 4 Messwerte (ca. 1,2 Sek.) 8: 8 Messwerte (ca. 2,4 Sek.) 16: 16 Messwerte (ca. 4,8 Sek.) 32: 32 Messwerte (ca. 9,6 Sek.) 64: 64 Messwerte (ca. 19,2 Sek.) 128: 128 Messwerte (ca. 38,4 Sek.)	8	
A80	Temperaturskala und Anzeige im Standby-Mode	0: Fahrenheit (AUS) 1: Celsius (AUS) 2: Fahrenheit (OFF) 3: Celsius (OFF)	1	
A81	Funktion externer Eingang E1	0: Keine Funktion 1: Regler Ein/Aus (Standby) 2: Sollwert S1' aktivieren 3. wie 2, LED 3 zeigt den Zustand	0	
A82	Funktion Taste 5	0: Keine Funktion 1: Regler Ein/Aus (Standby) 2: Sollwert P1 3: direkt Relais, bei Standby aus 4: direkt Relais, unabhängig von Standby	0	
A83	Funktion Taste 3	0: Keine Funktion 1: Regler Ein/Aus (Standby) 2: Sollwert P1 3: direkt Relais, bei Standby aus 4: direkt Relais, unabhängig von Standby	0	
A90	Ausgangsverbindung K1	0: Keine Verbindung 1: Verbindung zu Regelkontakt 1 2: Verbindung zu Regelkontakt 2 3: Verbindung zu Alarmkontakt 4: Verbindung zu Summerfunktion 5: Verbindung zu Taste 3 bzw. 5	1	

		6: Verbindung, wenn Regler an		
A91	Ausgangsverbindung K2	0: Keine Verbindung 1: Verbindung zu Regelkontakt 1 2: Verbindung zu Regelkontakt 2 3: Verbindung zu Alarmkontakt 4: Verbindung zu Summerfunktion 5: Verbindung zu Taste 3 bzw. 5 6: Verbindung, wenn Regler an	2	
A92	Ausgangsverbindung K3	0: Keine Verbindung 1: Verbindung zu Regelkontakt 1 2: Verbindung zu Regelkontakt 2 3: Verbindung zu Alarmkontakt 4: Verbindung zu Summerfunktion 5: Verbindung zu Taste 3 bzw. 5 6: Verbindung, wenn Regler an	3	
Pro	Anzeige Programmversion	-----	-----	

Statusmeldungen

Anzeige	Fehlerursache	Massnahmen
F1L	Fühlerfehler, Kurzschluss	Fühler kontrollieren
F1H	Fühlerfehler, Fühlerbruch	Fühler kontrollieren
"---"	Tastenverriegelung aktiv	siehe Parameter P19 bzw. A19
Blinkende Anzeige	Temperaturalarm	siehe Parameter A31
EP	Datenverlust im Parameterspeicher	Reparatur des Reglers (Regelkontakt 1 und 2 sind stromlos)

Fühlerfehlermeldungen gehen in jedem Fall mit einem Hupsignal einher. Durch Quittieren mit der AB-Taste kann das Hupsignal gelöscht werden. Ein Beseitigen der Fehlerursache führt zum selbsttätigen Verschwinden der Fehlermeldung und des Hupsignals.

Projekt / project: 2KP0160x01, 2KP160x11
2KP0250x01, 2KP250x11
2KP0400x01

Regler / controller: ST710-JB1BV.10 (-12N1) 451808.60.01
Sollwert / setpoint: 30°C +/-1K
Funktion / function: Regelung DI-Kreis / controller Di-circuit

Mikroprozessorgesteuerter Temperaturregler

Allgemeine Angaben

Der mikroprozessorgesteuerte Regler ST710-XX(1)XX.10 wird für thermostatische Temperaturregelung verwendet und verfügt dazu über einen Anschluß für Widerstandsfühler PTC oder Pt100. Das Gerät wird mit 230V AC versorgt und hat ein Ausgangsrelais.

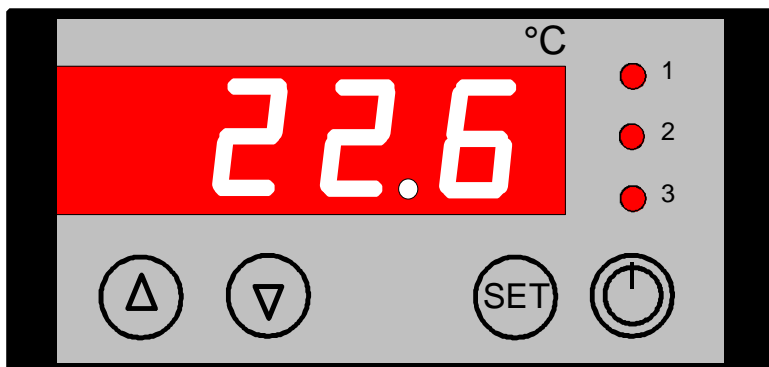

Beschreibung

Die Funktion des Temperatur-Reglers läßt sich durch Parametrierung aus einer Vielzahl von Möglichkeiten auswählen.



Taste 1: AUF-Taste:

Durch Betätigung dieser Taste für mindestens 3 Sek. wird eine Abtaugung angefordert und das Abtauintervall neu gestartet (Synchronisation der Abtaugung). Die nächste automatische Abtaugung erfolgt nun wieder nach der Zeit d0



Taste 2: AB-Taste

Mit dieser Taste kann ein Alarm quittiert werden.



Taste 4: SET-Taste



Taste 5: Stand-By

Temperature controller

General Data

The control unit ST710-XX(1)XX.10 is specially designed for thermostatic control-applications. The unit works together with resistance sensors (PTC or PT100).

The unit offers beyond the temperature regulation a wide range of other functions.

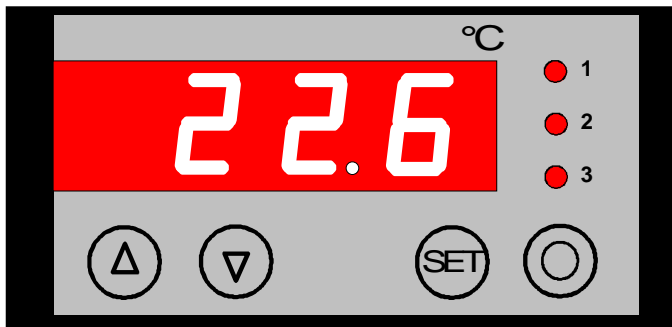

Description

The output can be programmed to different functions (Parameter A1).



Stand-By key:

The Stand-By function for this key can be selected by setting the parameter A82. The key has to be pressed for at least half a second.



SET-key:

The display normally shows the actual value. When the SET button is pressed, the display changes to show the Control Setpoint.



UP-key:

With the UP key it is possible to start a manual defrost.



DOWN-key:

With the DOWN key it is possible to cancel the alarm buzzer.

Einstellmöglichkeiten Setting options

Erste Bedienungsebene Parametrierung des Sollwertes



Der Sollwert S1 ist direkt durch Drücken der SET-Taste anwählbar.



Durch zusätzliches Drücken der AUF- oder AB-Taste kann er verstellt werden.

Durch entsprechende Parametereinstellungen (siehe A81) kann mit dem Schalteingang E1 eine Sollwertumschaltung (Funktion „Nachtabsenkung“) durchgeführt werden.

Bei geschlossenem Schalteingang E1 wird dann auf den modifizierten Sollwert S1' geregelt und entsprechend wird durch Drücken der SET-Taste der Sollwert S1' angezeigt.

S1' kann als Differenz zum Sollwert S1 definiert werden, oder als absoluter Sollwert (siehe Parameter A33).

First parameter level Setpoint Adjustment



The display normally shows the actual value of the process temperature. When the SET button is pressed, the display changes to show the control setpoint (desired temperature)



Simultaneously press the SET button with either the UP or DOWN button to increase or decrease the Setpoint. Please release the UP or DOWN button before releasing the SET button and the new value is loaded into the non-volatile memory.

Parameter <i>parameter</i>	Funktionsbeschreibung <i>function</i>	Einstellbereich <i>adjustable range</i>	Standard <i>standard</i>	Kunde <i>customer</i>
S1	Sollwert 1 setpoint	P4...P5	0,0 °C	30°C
S1'	Differenz zu Sollwert S1 (A33=1) (Sollwertanzeige blinkt) difference to setpoint S1 (A33=1) (display setpoint flashing) Absoluter Sollwert S1' (A33=2) (Sollwertanzeige statisch) absolute setpoint S1' (A33=2) (display setpoint static)	-99,0...999,0 K P4...P5	0,0 K 0,0 °C	

Liste der P-Parameter (2. Bedienungsebene)

P-level parameters (second level)

Parameter parameter	Funktionsbeschreibung function	Einstellbereich adjustable range	Standard standard	Kunde customer
P2	Hysterese K1 Hysteresis K1	0,1...99,9 K	1,0 K	0,4K
P4	Sollwertbegrenzung unten Control range limitation minimum setpoint	-99...P5	-99 °C	25°C
P5	Sollwertbegrenzung oben Control range limitation maximum setpoint	P4...999°C	999 °C	32°C
P6	Istwertkorrektur Actual value correction	-20,0...+20,0 K	0,0 K	
P19	Tastenverriegelung (Sollwertverstellung gesperrt) Keyboard lock (Setpoint lock)	0: Nicht verriegelt 0: not locked 1: Verriegelt 1: locked	0	
P30	unterer Grenzwert für Alarm Lower boundary value for alarm	-99...999°C	-99 °C	
P31	oberer Grenzwert für Alarm Upper boundary value for alarm	-99...999°C	999 °C	
P32	Alarmhysterese, einseitig Hysteresis alarm value, one-side	0,5...99,9 K	1,0 K	
d 0	Abtauintervall Defrost interval	0...99 h 0: keine Abtauung 0: no defrost function	0	
d 2	Abtautemperatur Defrost temperatur	-99,0...999,0°C	10,0 °C	
d 3	Abtauzeitbegrenzung Defrost time limit	0...99 min 0: ohne Zeitbegrenzung 0: without time limit	30 min	

Liste der A-Parameter (3. Bedienungsebene)

A-level parameters (third level)

Parameter <i>parameter</i>	Funktionsbeschreibung <i>function</i>	Einstellbereich <i>adjustable range</i>	Standard <i>standard</i>	Kunde <i>customer</i>
A1	Schaltsinn K1 Switch mode K1	0: Heizkontakt 0: Heating contact 1: Kühlkontakt 1: Cooling contact 2: Alarmfunktion K1 2: Alarm contact (P30 + P31) 3: Alarmfunktion (K1 invertiert) 3: Alarm contact (function K1 inverted)	0	1
A3	Funktion von K1 bei Fühlerfehler On Sensor Error (K1 Relay action)	0: Bei Fehler ab 0: Relay off 1: Bei Fehler an 1: Relay on	0	
A8	Istwert – Anzeigemodus (die sonstigen Parameter werden mit Auflösung 0,1K dargestellt) Actual value display (all other Parameters remain 0.1 °K resolution)	0: Ganzzahlig 0: Whole numbers 1: Auflösung 0,5K 1: 0,5 °K resolution 2: Auflösung 0,1K 2: 0,1 °K resolution	1	2
A10	Anzeigewert für 0V (nur bei Linearfühler) Voltage input Tu	-99...999	0	
A11	Anzeigewert für 10V (nur bei Linearfühler) Voltage input To	-99...999	100	
A19	Parameterverriegelung Parameter locking	0: keine Verriegelung 0: no lock 1: A-Parameter verriegelt 1: A-parameters locked 2: A- und P-Parameter verriegelt 2: A+P-parameters locked	0	
A30	Art der Alarmfunktion alarm functions	0: Grenzwertalarm relative Grenzen 0: Boundary alarm relative boundaries 1: Grenzwertalarm, absolute Grenzen 1: Boundary alarm, absolute boundaries 2: Bandalarm, relative Grenzen 2: Range alarm, relative boundaries 3: Bandalarm, absolute Grenzen 3: Range alarm, absolute boundaries	0	

A31	Sonderfunktion für Alarm (Summer und Anzeige) Other alarm functions (buzzer+display)	0: Nicht aktiv 0: Without function 1: blinkende Anzeige bei Alarm 1: Display flashing 2: Summer ertönt bei Alarm 2: Buzzer active 3: blinkende Anzeige und Summer 3: Display flashes and buzzer active	0	
A32	Art der Anzeige Display mode	0: Istwertanzeige 0: actual value 1: Sollwertanzeige 1: Setpoint	0	
A33	Art von Sollwert S1' Setpoint 1' configuration	0: Keine Funktion 0: not activated 1: Relativ zu Sollwert S1 1: relative to Setpoint S1 2: Frei einstellbar (absolut) 2: Free adjust (absolute)	0	
A40	Hysteresemodus K1 Hysteresis-mode K1	0: Symmetrisch 0: Symmetrical 1: Einseitig 1: One side of Setpoint	1	0
A50	Mindestaktionszeit K1 "Ein" Minimum ON time K1	0...400 s	0 s	
A51	Mindestaktionszeit K1 "Aus" Minimum OFF time K1	0...400 s	0 s	
A54	Verzögerung K1 nach "Netz-Ein" Time delay relay K1 after mains ON	0...400 s	0 s	
A56	Alarmunterdrückung nach "Netz-Ein" Alarm signal delay after mains ON	0...60 min	20 min	
A60	Fühlerauswahl Sensor selection	11: PT100 Zweileiteranschluss 11: PT100 2-wire 12: PT100 Dreileiteranschluss 12: PT100 3-wire 21: PTC 21: KTY81-121 2-wire 22: PT1000 Zweileiteranschluss 22: PT1000 2-wire 23: PT1000 Dreileiteranschluss 23: PT1000 3-wire	Abhängig von Hardware Depends On hardware	12

A70	Softwarefilter <i>Software time constant</i>	<p>1: nicht aktiv 1: not active</p> <p>Mittelwert über: average value:</p> <p>2: 2 Messwerte (ca. 0,6s) 2: 2 <i>measurands</i> (ca. 0,6s)</p> <p>4: 4 Messwerte (ca. 1,2s) 4: 4 <i>measurands</i> (ca. 1,2s)</p> <p>8: 8 Messwerte (ca. 2,4s) 8: 8 <i>measurands</i> (ca. 2,4s)</p> <p>16: 16 Messwerte (ca. 4,8s) 16: 16 <i>measurands</i> (ca. 4,8s)</p> <p>32: 32 Messwerte (ca. 9,6s) 32: 32 <i>measurands</i> (ca. 9,6s)</p> <p>64: 64 Messwerte (ca. 19,2s) 64: 64 <i>measurands</i> (ca. 19,2s)</p> <p>128: 128 Messwerte (ca. 38,4s) 128: 128 <i>measurands</i> (ca. 38,4s)</p>	32	
A80	Temperaturskala und Darstellung von Stand-By Temperature scale and display at Stand-By	<p>0: Fahrenheit und AUS 0: Fahrenheit and "AUS"</p> <p>1: Celsius und AUS 1: Celsius and "AUS"</p> <p>2: Fahrenheit und OFF 2: Fahrenheit and "OFF"</p> <p>3: Celsius und OFF 3: Celsius and "OFF"</p>	1	
A81	Funktion E1 Function E1	<p>0: Keine Funktion 0: no function</p> <p>1: Regler Ein/Aus (StandBy) 1: Controller ON/OFF (Stand-By)</p> <p>2: Sollwert S1' aktiviert 2: Setpoint S1' activated</p>	0	
A82	Funktion Taste 5 Function button 5	<p>0: Keine Funktion 0: no function</p> <p>1: Regler Ein/Aus (StandBy) 1: Controller ON/OFF (Stand-By)</p>	0	
Pro	Programmversion Program version	-	-	

Status-/Fehlermeldungen

Status and error messages

Anzeige <i>display</i>	Fehlerursache <i>cause</i>	Massnahmen <i>Action</i>
F1L	Fühlerfehler, Kurzschluss Sensor failure F1 (short circuit at sensor)	Fühler kontrollieren bzw. tauschen Check sensor, possibly change sensor
F1H	Fühlerfehler, Fühlerbruch Sensor failure F1 (broken sensor or no sensor connected)	Fühler kontrollieren bzw. tauschen Check sensor, possibly change sensor
---	Tastensperre aktiv Keyboard lock. Message appears while trying to change setpoint but keyboard is locked at parameter P19/A19	siehe Parameter P19 oder A19 Check out parameter P19 or A19
Blinkende Anzeige Flashing display	Temperaturalarm (siehe A31) Limit value alarm (A31)	
EP	Datenverlust im Parameterspeicher Error in EEPROM (data lost)	Reparatur des Reglers durch Hersteller Repair of the controller by manufacturer, change controller

Durch quittieren mit der AB-Taste kann der Summer ausgeschaltet werden.
Buzzer can be switched off by pressing the DOWN-button.

Projekt / project: 2KP0063x02, 2KP0063x12
2KP0160x01, 2KP160x11
2KP0250x01, 2KP250x11
2KP0400x01

Regler / controller: ST710-JB1BV.10 (-13N1)
Sollwert / setpoint: 18°C
Funktion / function: Vortemperierung / pre-heating

Mikroprozessorgesteuerter Temperaturregler

Allgemeine Angaben

Der mikroprozessorgesteuerte Regler ST710-XX(1)XX.10 wird für thermostatische Temperaturregelung verwendet und verfügt dazu über einen Anschluß für Widerstandsfühler PTC oder Pt100. Das Gerät wird mit 230V AC versorgt und hat ein Ausgangsrelais.

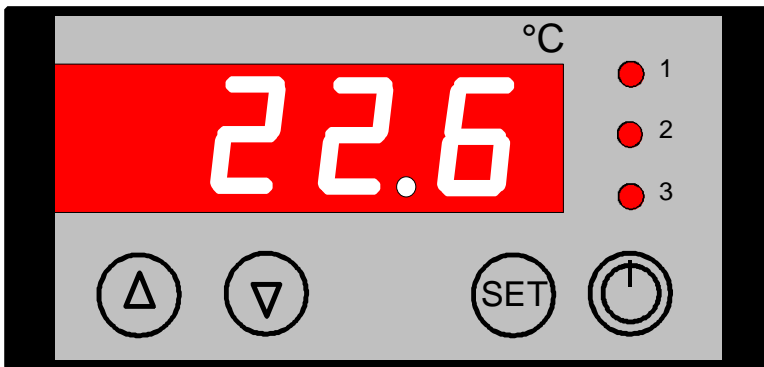

Beschreibung

Die Funktion des Temperatur-Reglers läßt sich durch Parametrierung aus einer Vielzahl von Möglichkeiten auswählen.



Taste 1: AUF-Taste:

Durch Betätigung dieser Taste für mindestens 3 Sek. wird eine Abtaung angefordert und das Abtauintervall neu gestartet (Synchronisation der Abtaung). Die nächste automatische Abtaung erfolgt nun wieder nach der Zeit d0



Taste 2: AB-Taste

Mit dieser Taste kann ein Alarm quittiert werden.



Taste 4: SET-Taste



Taste 5: Stand-By

Temperature controller

General Data

The control unit ST710-XX(1)XX.10 is specially designed for thermostatic control-applications. The unit works together with resistance sensors (PTC or PT100).

The unit offers beyond the temperature regulation a wide range of other functions.

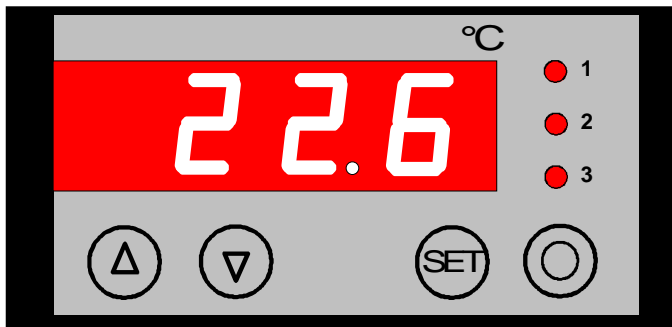

Description

The output can be programmed to different functions (Parameter A1).



Stand-By key:

The Stand-By function for this key can be selected by setting the parameter A82. The key has to be pressed for at least half a second.



SET-key:

The display normally shows the actual value. When the SET button is pressed, the display changes to show the Control Setpoint.



UP-key:

With the UP key it is possible to start a manual defrost.



DOWN-key:

With the DOWN key it is possible to cancel the alarm buzzer.

Einstellmöglichkeiten Setting options

Erste Bedienungsebene Parametrierung des Sollwertes



Der Sollwert S1 ist direkt durch Drücken der SET-Taste anwählbar.



Durch zusätzliches Drücken der AUF- oder AB-Taste kann er verstellt werden.

Durch entsprechende Parametereinstellungen (siehe A81) kann mit dem Schalteingang E1 eine Sollwertumschaltung (Funktion „Nachtabsenkung“) durchgeführt werden.

Bei geschlossenem Schalteingang E1 wird dann auf den modifizierten Sollwert S1' geregelt und entsprechend wird durch Drücken der SET-Taste der Sollwert S1' angezeigt.

S1' kann als Differenz zum Sollwert S1 definiert werden, oder als absoluter Sollwert (siehe Parameter A33).

First parameter level Setpoint Adjustment



The display normally shows the actual value of the process temperature. When the SET button is pressed, the display changes to show the control setpoint (desired temperature)



Simultaneously press the SET button with either the UP or DOWN button to increase or decrease the Setpoint. Please release the UP or DOWN button before releasing the SET button and the new value is loaded into the non-volatile memory.

Parameter <i>parameter</i>	Funktionsbeschreibung <i>function</i>	Einstellbereich <i>adjustable range</i>	Standard <i>standard</i>	Kunde <i>customer</i>
S1	Sollwert 1 setpoint	P4...P5	0,0 °C	18°C
S1'	Differenz zu Sollwert S1 (A33=1) (Sollwertanzeige blinkt) difference to setpoint S1 (A33=1) (display setpoint flashing) Absoluter Sollwert S1' (A33=2) (Sollwertanzeige statisch) absolute setpoint S1' (A33=2) (display setpoint static)	-99,0...999,0 K P4...P5	0,0 K 0,0 °C	

Liste der P-Parameter (2. Bedienungsebene) P-level parameters (second level)

Parameter <i>parameter</i>	Funktionsbeschreibung <i>function</i>	Einstellbereich <i>adjustable range</i>	Standard <i>standard</i>	Kunde <i>customer</i>
-------------------------------	--	--	-----------------------------	--------------------------

P2	Hysterese K1 Hysteresis K1	0,1...99,9 K	1,0 K	2K
P4	Sollwertbegrenzung unten Control range limitation minimum setpoint	-99...P5	-99 °C	9°C
P5	Sollwertbegrenzung oben Control range limitation maximum setpoint	P4...999°C	999 °C	19°C
P6	Istwertkorrektur Actual value correction	-20,0...+20,0 K	0,0 K	
P19	Tastenverriegelung (Sollwertverstellung gesperrt) Keyboard lock (Setpoint lock)	0: Nicht verriegelt 0: not locked 1: Verriegelt 1: locked	0	
P30	unterer Grenzwert für Alarm Lower boundary value for alarm	-99...999°C	-99 °C	
P31	oberer Grenzwert für Alarm Upper boundary value for alarm	-99...999°C	999 °C	
P32	Alarmhysterese, einseitig Hysteresis alarm value, one-side	0,5...99,9 K	1,0 K	
d 0	Abtauintervall Defrost interval	0...99 h 0: keine Abtauung 0: no defrost function	0	
d 2	Abtautemperatur Defrost temperatur	-99,0...999,0°C	10,0 °C	
d 3	Abtauzeitbegrenzung Defrost time limit	0...99 min 0: ohne Zeitbegrenzung 0: without time limit	30 min	

Liste der A-Parameter (3. Bedienungsebene) A-level parameters (third level)

Parameter <i>parameter</i>	Funktionsbeschreibung <i>function</i>	Einstellbereich <i>adjustable range</i>	Standard <i>standard</i>	Kunde <i>customer</i>
A1	Schallsinn K1	0: Heizkontakt	0	

	Switch mode K1	0: Heating contact 1: Kühlkontakt 1: Cooling contact 2: Alarmfunktion K1 2: Alarm contact (P30 + P31) 3: Alarmfunktion (K1 invertiert) 3: Alarm contact (function K1 inverted)		
A3	Funktion von K1 bei Fühlerfehler On Sensor Error (K1 Relay action)	0: Bei Fehler ab 0: Relay off 1: Bei Fehler an 1: Relay on	0	
A8	Istwert – Anzeigemodus (die sonstigen Parameter werden mit Auflösung 0,1K dargestellt) Actual value display (all other Parameters remain 0.1 °K resolution)	0: Ganzzahlig 0: Whole numbers 1: Auflösung 0,5K 1: 0,5 °K resolution 2: Auflösung 0,1K 2: 0,1 °K resolution	1	2
A10	Anzeigewert für 0V (nur bei Linearfühler) Voltage input Tu	-99...999	0	
A11	Anzeigewert für 10V (nur bei Linearfühler) Voltage input To	-99...999	100	
A19	Parameterverriegelung Parameter locking	0: keine Verriegelung 0: no lock 1: A-Parameter verriegelt 1: A-parameters locked 2: A- und P-Parameter verriegelt 2: A+P-parameters locked	0	
A30	Art der Alarmfunktion alarm functions	0: Grenzwertalarm relative Grenzen 0: Boundary alarm relative boundaries 1: Grenzwertalarm, absolute Grenzen 1: Boundary alarm, absolute boundaries 2: Bandalarm, relative Grenzen 2: Range alarm, relative boundaries 3: Bandalarm, absolute Grenzen 3: Range alarm, absolute boundaries	0	
A31	Sonderfunktion für Alarm (Summer und Anzeige) Other alarm functions (buzzer+display)	0: Nicht aktiv 0: Without function 1: blinkende Anzeige bei Alarm 1: Display flashing	0	

		2: Summer ertönt bei Alarm 2: Buzzer active 3: blinkende Anzeige und Summer 3: Display flashes and buzzer active		
A32	Art der Anzeige Display mode	0: Istwertanzeige 0: actual value 1: Sollwertanzeige 1: Setpoint	0	
A33	Art von Sollwert S1' Setpoint 1' configuration	0: Keine Funktion 0: not activated 1: Relativ zu Sollwert S1 1: relative to Setpoint S1 2: Frei einstellbar (absolut) 2: Free adjust (absolute)	0	
A40	Hysteresemodus K1 Hysteresis-mode K1	0: Symmetrisch 0: Symmetrical 1: Einseitig 1: One side of Setpoint	1	0
A50	Mindestaktionszeit K1 "Ein" Minimum ON time K1	0...400 s	0 s	120s
A51	Mindestaktionszeit K1 "Aus" Minimum OFF time K1	0...400 s	0 s	
A54	Verzögerung K1 nach "Netz-Ein" Time delay relay K1 after mains ON	0...400 s	0 s	
A56	Alarmunterdrückung nach "Netz-Ein" Alarm signal delay after mains ON	0...60 min	20 min	
A60	Fühlerauswahl Sensor selection	11: PT100 Zweileiteranschluss 11: PT100 2-wire 12: PT100 Dreileiteranschluss 12: PT100 3-wire 21: PTC 21: KTY81-121 2-wire 22: PT1000 Zweileiteranschluss 22: PT1000 2-wire 23: PT1000 Dreileiteranschluss 23: PT1000 3-wire	Abhängig von Hardware Depends On hardware	12
A70	Softwarefilter <i>Software time constant</i>	1: nicht aktiv 1: not active Mittelwert über: average value: 2: 2 Messwerte (ca. 0,6s) 2: 2 <i>measurands</i> (ca. 0,6s) 4: 4 Messwerte (ca. 1,2s) 4: 4 <i>measurands</i> (ca. 1,2s) 8: 8 Messwerte (ca. 2,4s) 8: 8 <i>measurands</i> (ca. 2,4s) 16: 16 Messwerte (ca. 4,8s)	32	8

		16: 16 <i>measurands</i> (ca. 4,8s) 32: 32 Messwerte (ca. 9,6s) 32: 32 <i>measurands</i> (ca. 9,6s) 64: 64 Messwerte (ca. 19,2s) 64: 64 <i>measurands</i> (ca. 19,2s) 128: 128 Messwerte (ca. 38,4s) 128: 128 <i>measurands</i> (ca. 38,4s)		
A80	Temperaturskala und Darstellung von Stand-By Temperature scale and display at Stand-By	0: Fahrenheit und AUS 0: Fahrenheit and "AUS" 1: Celsius und AUS 1: Celsius and "AUS" 2: Fahrenheit und OFF 2: Fahrenheit and "OFF" 3: Celsius und OFF 3: Celsius and "OFF"	1	
A81	Funktion E1 Function E1	0: Keine Funktion 0: no function 1: Regler Ein/Aus (StandBy) 1: Controller ON/OFF (Stand-By) 2: Sollwert S1' aktiviert 2: Setpoint S1' activated	0	
A82	Funktion Taste 5 Function button 5	0: Keine Funktion 0: no function 1: Regler Ein/Aus (StandBy) 1: Controller ON/OFF (Stand-By)	0	
Pro	Programmversion Program version	-	-	

Status-/Fehlermeldungen

Status and error messages

Anzeige <i>display</i>	Fehlerursache <i>cause</i>	Massnahmen <i>Action</i>
F1L	Fühlerfehler, Kurzschluss Sensor failure F1	Fühler kontrollieren bzw. tauschen Check sensor, possibly change sensor

	<i>(short circuit at sensor)</i>	
F1H	Fühlerfehler, Fühlerbruch Sensor failure F1 <i>(broken sensor or no sensor connected)</i>	Fühler kontrollieren bzw. tauschen Check sensor, possibly change sensor
---	Tastenverriegelung aktiv Keyboard lock. Message appears while trying to change setpoint but keyboard is locked at parameter P19/A19	siehe Parameter P19 oder A19 Check out parameter P19 or A19
Blinkende Anzeige Flashing display	Temperaturalarm (siehe A31) Limit value alarm (A31)	
EP	Datenverlust im Parameterspeicher Error in EEPROM (data lost)	Reparatur des Reglers durch Hersteller Repair of the controller by manufacturer, change controller

Durch quittieren mit der AB-Taste kann der Summer ausgeschaltet werden.
Buzzer can be switched off by pressing the DOWN-button.