

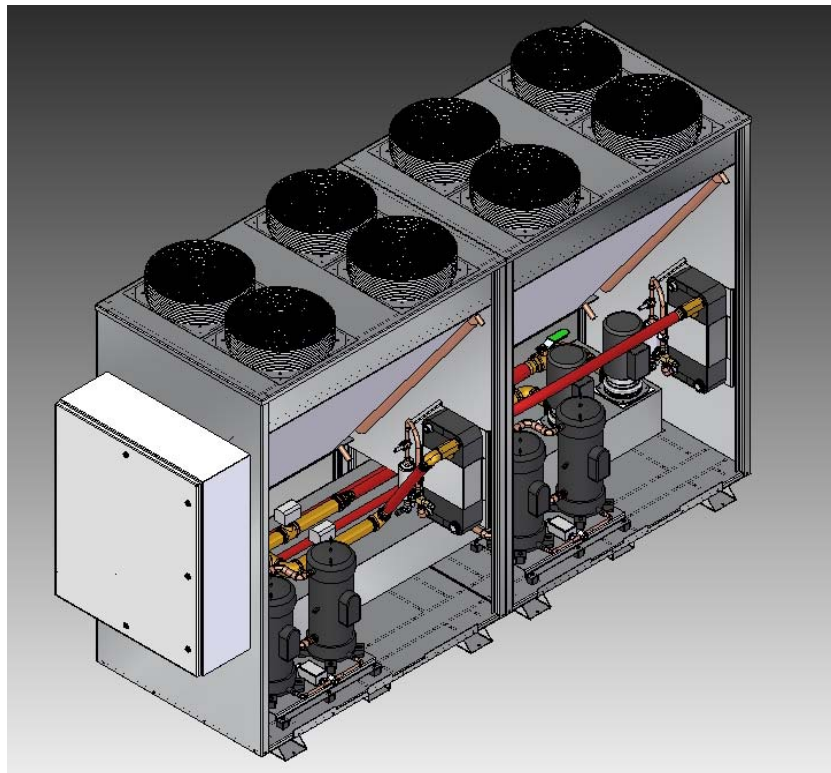

HEAT EXCHANGER OPERATING MANUAL

Open System Models (Seismic)
WO2-2-7500-2P-NF-L-M-R407C
WO2-2-5000-2P-NF-L-M-R407C
REVISION 2



REVISION HISTORY

LEVEL	DATE	REVISION DESCRIPTION	SIGNATURES
1	14 June 2011	Initial Release	
2	26 July 2011	Update Product Configuration Chart	

PRODUCT CONFIGURATIONS

Configuration	GE PN	Supplier PN	07#	Revision	Supplier Model #	Size
Standard System	E8911CA-Seismic	WO2-2-7500-15002990-GE	0717015002974	000	WO2-2-7500-2P-NF-L-M-R407C	750W/750/450 (30 Ton)
Standard + Coastal	E8911CB-Seismic	WO2-2-7500-SS-15002990-GE	0717015002973	000	WO2-2-7500-2P-NF-L-M-R407C	750W/750/450 (30 Ton)
Standard System	E8912CA-Seismic	WO2-2-5000-10002995-GE	0717010002986	000	WO2-2-5000-2P-NF-L-M-407C	450w (20 Ton)
Standard + Coastal	E8912CB	WO2-2-5000-SS-10002995-GE	0717010002985	000	WO2-2-5000-2P-NF-L-M-407C	450w (20 Ton)

Table of Contents

Article I.	FOR YOUR SAFETY	5
Article II.	INSTALLATION AND START-UP	6
Article III.	CONTROLLER OPERATION	9
	Section 3.01 Introduction:.....	9
	Section 3.02 Initialization of Controller:.....	10
	Section 3.03 Starting the System:.....	10
	Section 3.04 Enabling Devices:.....	10
	Section 3.05 Changing the Setpoint:.....	11
	Section 3.06 Viewing Alarms:.....	11
	Section 3.07 Sequence of Operation:.....	11
Article IV.	HEAT EXCHANGER COMPONENTS	12
Article V.	WATER TREATMENT	16
Article VI.	MAINTENANCE	17
	Section 6.01 Condenser: Cleaning Air Filters and Condenser.....	17
	Section 6.02 Electric Motors.....	17
	Section 6.03 Check Water Quality / Test Glycol Mixture.....	17
	Section 6.04 Inspect and Clean Fluid Strainer.....	17
	Section 6.05 Inspect Fluid System for Leaks Or Loose Connection.....	18
	Section 6.06 Check All Wiring For Loose Connections, Chaffing Or Damage.....	18
	Section 6.07 Inspect And Test Refrigeration System For Leaks.....	18
Article VII.	HEAT EXCHANGER SPECIFICATIONS	19
Article VIII.	TROUBLESHOOTING SERVICE GUIDE	20
Article IX.	SPARE PARTS GUIDE	21
Article X.	MSDS	22
Article XI.	COMPONENT INFORMATION	32
Article XII.	DRAWINGS	68

Article I. FOR YOUR SAFETY

1. Signs and Symbols:

Throughout the operating manual, the information and notices below are identified by graphical symbols.



DANGER!

Safety note indicating imminent danger. Failure to heed the warning may result in serious bodily injury and even death.



CAUTION!

Safety note indicating the presence of potential hazard. Failure to heed the safety notice may result in minor bodily injury or damage to the equipment.



INFORMATION!

This symbol identifies important information or a useful tip concerning the application or service of the unit.

2. Safety Notes:

For the installation and operation of the heat exchanger, the following regulations and safety notes have to be observed.



Any work on the heat exchanger may only be performed by qualified personnel. All relevant accident prevention regulations have to be observed.

The eletro-technical connection of the heat exchanger must be performed according to all relevant national and local standards.

Before attempting to carry out any work on the heat exchanger, always disconnect the unit from the power supply.



Any national regulations applicable in the country of installation must be observed.



The fluid must comply with KOOLANT KOOLERS specifications. Watch for an incompatibilities of materials in the entire fluid circuit.

3. Handling of refrigerants:

When handing refrigerants it is imperative that the relevant statutory regulations and guidelines be complied with. Only adequately skilled personnel may carry out this kind of work.



The proper disposal of refrigerants and parts of the system that are no longer serviceable lies within the responsibility of the operator of the facility.

Article II. INSTALLATION AND START-UP

- 1) **Outdoor Use:** The Heat Exchanger is designed to be installed outdoors, but is suitable for installation indoors provided the space can dissipate the heat rejected from the Heat Exchanger.
- 2) **Misuse:** The Heat Exchanger has potential for misuse that could result in unplanned downtime. The main disconnect, drain and possibly field installed service valves can be operated by unauthorized personnel. If unauthorized is a concern then a security fence should be provided to reduce the potential for misuse. Fencing must not obstruct airflow and must leave room or be removable for service.
- 3) **Leveling the Unit:** Make sure unit is placed, on a flat, level, hard surface. Heat Exchanger must be level or less than $\frac{1}{2}$ inch of slope per 10 feet with the electrical box end of the Heat Exchanger at the high point. Use shims to correct level if needed. If a concrete slab is utilized, a 4 inch depth is adequate; pad should be at least 5 feet x 12 feet. If mounted on roof, two i-beams runners are typically provided to support feet at both ends. Heat Exchanger should be anchored from the feet mounting holes at the four corners of the machine. When mounted above office space, optional vibration mounting springs can be used to mount the Heat Exchanger, a spring mount will be provided for both ends of each foot.
- 4) **Proper Spacing:** The unit should be located where adequate air circulation is provided with room for servicing. As a general guideline for units with vertical air discharge (fans located on top), keep the unit at least *5 feet away from walls* and allow at least an *8 foot clearance above* the unit.¹ For units with horizontal air discharge (fans located on side), keep the side containing the fans a minimum of *15 feet from the wall*. The side containing the *filter should be a minimum of 6 feet from the wall*. Avoid placing the Heat Exchanger under or near eaves which may reflect the discharge air back into the air inlet². Do not place in a poorly ventilated room. The build-up of high ambient temperatures can cause compressor and or machine damage³



CAUTION: Heat Exchanger must not be installed more than 65 feet above the heat exchangers and cryo compressor. The Heat Exchanger pumps can deliver up to 165 feet of head and the heat exchangers and cryo compressor are rated at 230 feet of head max. If the Heat Exchanger is mounted more than 65 feet above the heat exchangers and cryo compressor, the maximum allowable pressure on the heat exchangers and cryo compressor may be exceeded. Consult factory for installations requiring the Heat Exchanger to be installed more than 65 feet above the Heat Exchanger.

- 5) **Connection of Water Piping:** The material and nominal widths of the pipes must be selected according to KOOLANT KOOLERS specifications. See dimensions in Article VII. Connect the fluid lines to the proper piping marked "**FLUID INLET TO HEAT EXCHANGER**" and "**FLUID OUTLET FROM HEAT EXCHANGER**". Make sure that the flow of fluid to and from the unit can not be shut off or blocked while the Heat Exchanger is in operation, and the pipe size matches specifications.

¹ Do not place in a mezzanine, near a ceiling or in an enclosed room without consulting factory.

² Note: Placing Heat Exchanger under or near eaves that can result in ice damage or damage to the eave as a result of hot air discharge.

³ If there is a concern about adequate ventilation for the Heat Exchanger please consult the factory.

- 6) **Length and Distance of Flow:** The maximum equivalent linear feet of total piping which may be installed external to the Heat Exchanger is 500ft. using 2" plumbing.⁴ This is total piping which includes the feed and return to the heat exchangers and cryo compressor. The Heat Exchanger can pump fluid vertically up to 75 feet (usually 6 stories).

Standard Fitting Losses in Equivalent Feet of Pipe

2inch 90° Standard Elbow:	05.0ft. loss
2inch 90° Street Elbow:	08.2ft. loss
2inch 45° Standard Elbow:	02.6ft. loss
2inch 45° Street Elbow:	04.5ft. loss
2inch Globe Valve:	55.0ft. loss
2inch Gate Valve:	02.3ft. loss
2inch Angle Valve:	24.0ft. loss

- 7) **Voltage and Power:** Check building power to ensure it matches the Heat Exchanger rated voltage and current. Voltage and circuit ampacity of the unit can be found on the data tag which is located on the front of the electrical panel or the electrical drawings. Connect power leads to main disconnect⁵.
- 8) **Remote Display:** If a remote display (Figure 1) is provided with the unit, install the provided 150 foot communications cable between the Heat Exchanger electrical panel and the remote display location. For distances in excess of 150 feet, an optional Long Distance Remote Display kit is required⁶. See *Initialization of Controller:* section for remote display plug connection point on master controller.



Figure 1
Remote display and communication cable



CAUTION: Heat Exchangers installed with a crankcase heater require the electrical panel disconnect to be in the "ON" position for a minimum of 8 hours before start-up of unit. Leaving the Disconnect in the "ON" position maintains power to the compressor crankcase heater, preventing refrigerant migration and possible damage to system. Power can be off for 30 minutes for service without observing the 8 hour pre-heat requirement.

- 9) Units are shipped with refrigeration service valves in the open (back-seated) position and do not require any adjustments. Service valves should only be adjusted by a certified technician.



⁴ **NOTE:** If the equivalent piping exceeds 500' please contact the factory for assistance. 1-800-968-5665

⁵ Wiring should match Heat Exchanger disconnect size and power requirements in accordance with local codes.

⁶ Contact the parts department if the distance to remote location exceeds 150ft.

- 10) **Fill Unit:** Fill the reservoir through the fill/sight glass. You will know it is properly filled when water level remains between the two black level markers located on the sight glass.



CAUTION: Do not allow the fluid pumps to run dry. This will damage the pump seals and will not be covered under warranty.

- 11) **Turn On Unit:** Once Heat Exchanger reservoir has been filled, proceed to turn the main power disconnect on located on the electrical box door. Defeat the disconnect handle to open the electrical box door. Phase monitor light must be green and master controller alarms should be clear. Turn the system on. See the **CONTROLLER OPERATION** for more information on operation of the master controller.



Caution: Electrical Shock Hazard - Use appropriate personal protective equipment rated for exposure to 460 volts when within 3 feet of open electrical enclosure.

- 12) If pump motors do not start, check incoming power for correct sequence. If incoming power is present, check any faults on the master controller. Reset any faults which may be present.
- 13) Proceed to run Heat Exchanger pump for five minutes or more to allow any air in the system to be vented. Check fluid level after air is purged from the piping. Fill reservoir as needed.
- 14) Check controller for fault messages. Clear faults that may have occurred during start-up procedure. If faults do not re-occur, the system is ready for continuous duty.

Article III. CONTROLLER OPERATION

Section 3.01 Introduction:

On the Heat Exchanger unit there are multiple controllers as shown in Figure 2. These controllers communicate to a remote display called a PGD display which is shown in Figure 3. The Heat Exchanger status, settings and alarms can all be viewed and reset through the PGD display.

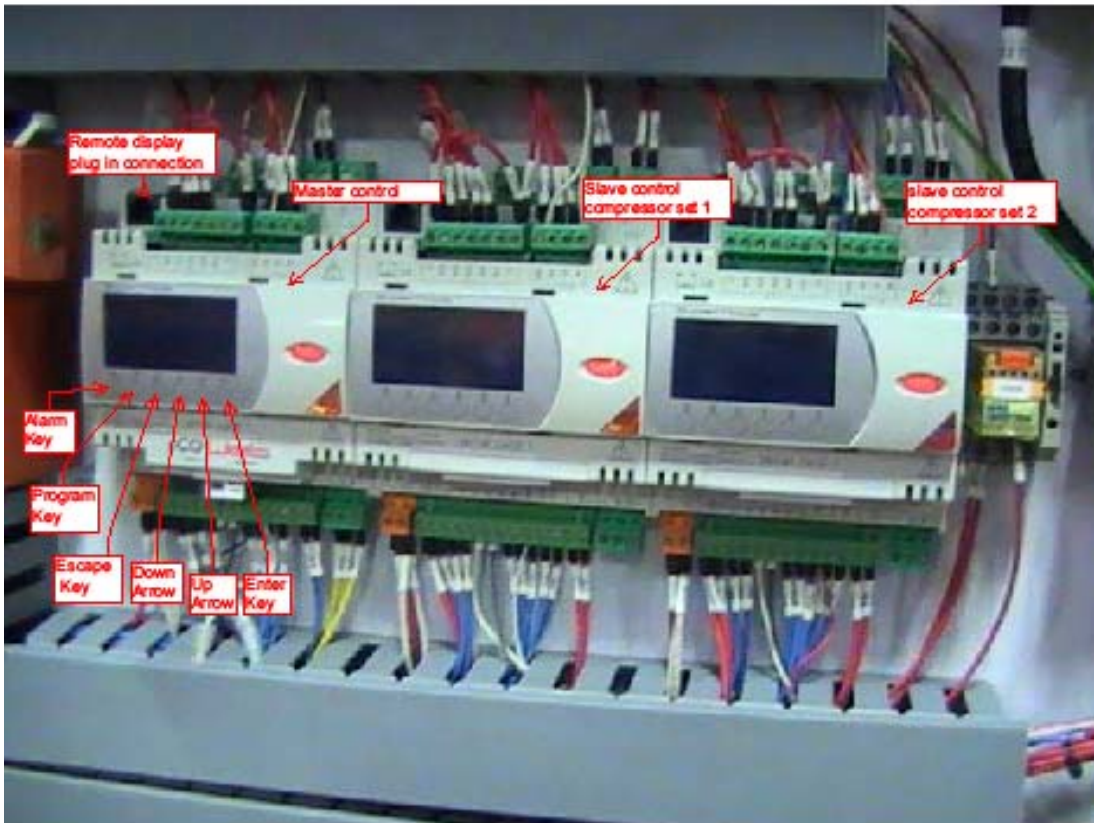

Figure 2



Figure 3

Section 3.02 Initialization of Controller:

When the unit is first powered up after a download it goes through a self-test and requires a reboot after initialization. Cycle power to the controller if the message in Figure 4 is displayed.

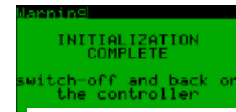

Figure 4

When the controller has finished its initial self test, the main page will be displayed. This displays the current time, date, unit #, fluid temperature, setpoint and system status. The page will look similar to Figure 5.

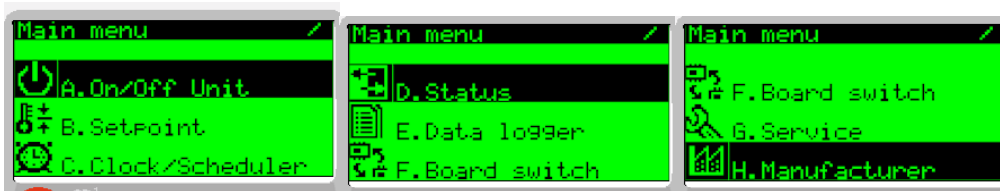

Figure 5

Section 3.03 Starting the System:

The system status displays the current status of the on/off switch.

Turn the system on: Press the "Prg" key and the main menu will be displayed over three screens. Highlight the menu labeled "A. ON/OFF Unit" and press the "Enter" key.



The next page will look similar to Figure 6. Press the "Enter" key again, to move the cursor over the "SWITCH OFF". Press the up arrow key to change the status to "SWITCH ON"

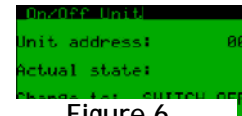

Figure 6

Section 3.04 Enabling Devices:

The pump and compressors can be individually enabled using the Enable/Disable function. To enable/disable devices press the "Prg" key to view the main menu. Highlight the menu labeled "G. SERVICE" and press the "Enter" key. Use the arrow keys to highlight the menu labeled "C. ENABLE/DISABLE" and press the "Enter" key again. The first page should display the Process Pumps similar to Figure 7. The three options for process pumps are:

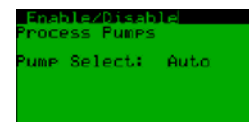

Figure 7

- Auto** = Selects pump based on time and switches on flow alarm (if enabled) & overload alarm
- #1** = Selects only pump #1 to run
- #2** = Selects only pump #2 to run

Once the Process Pumps have been selected, press the "↓" arrow key to change the page to Circuit #1. To enable the compressor(s), use the "Enter" key and the arrow keys to change the status from "No" to "Yes". Complete for any additional circuits on the unit. The number of compressors and circuits will depend on the design of the unit.

Section 3.05 Changing the Setpoint:

To turn the system on press the “Prg” key and the main menu will be displayed. Highlight the menu labeled “B. SETPOINT” and press the “Enter” key. The page will look similar to Figure 8. Press the “Enter” key again, to move the cursor over the fluid setpoint temperature. Use the arrow keys to change the temperature and press the “Enter” key to accept. Press the “Esc” key to return back to the main menu.



Figure 8

Section 3.06 Viewing Alarms:

When an alarm occurs the red alarm light on the PGD display will light up (a buzzer will activate if not disabled). To view this alarm, press the “Alarm” key and the alarms will be displayed. To view all active alarms, use the arrow keys to scroll up and down. To clear all inactive alarms, press and hold the “Alarm” key. At the end of the alarms a page similar to Figure 9 will be displayed. Press the “Enter” key and you will be taken to the Alarm Log page where you can view the alarm history.

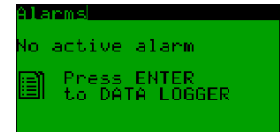

Figure 9

Section 3.07 Sequence of Operation:

Upon system start, with all compressors and pumps enabled a brief delay will occur and then the pump that didn't run during the last occurrence will start first. If flow is approved on either heat exchanger, the pump will continue to run. If no flow is established after a flow fault delay time, the opposing pump will automatically start. Pumps will rotate once every 24 hours to balance run time.

Once flow is established and cooling demand increases to 25%, the compressor that hasn't run in the longest period of time will start. As cooling demand increases to 50%, the compressor in the alternate compressor set that hasn't run in the longest period of time will start. At a cooling demand of 75% and 100% the remaining compressors will stage up. When cooling demand decreases by 25% from a compressor start percentage, a compressor will cycle off, compressors drop out in a 'first in-first out' sequence. The cooling demand signal is proportional and integral driven so the cycling of compressors should slowly correct to be centered about set point.

Article IV. HEAT EXCHANGER COMPONENTS

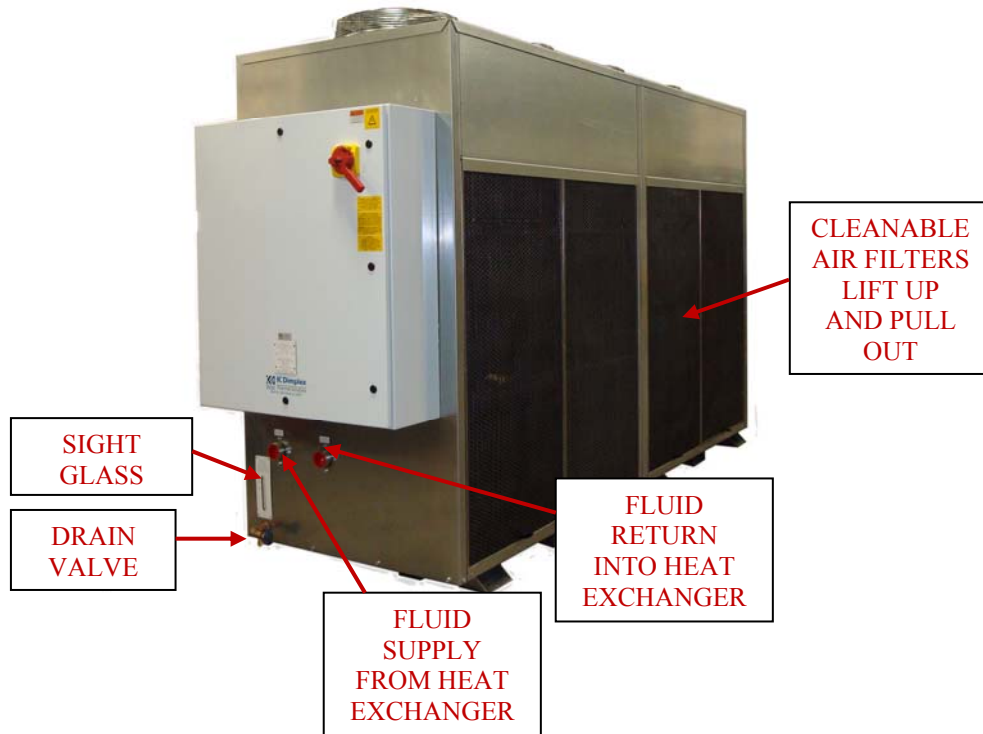

Heat Exchanger Main Parts

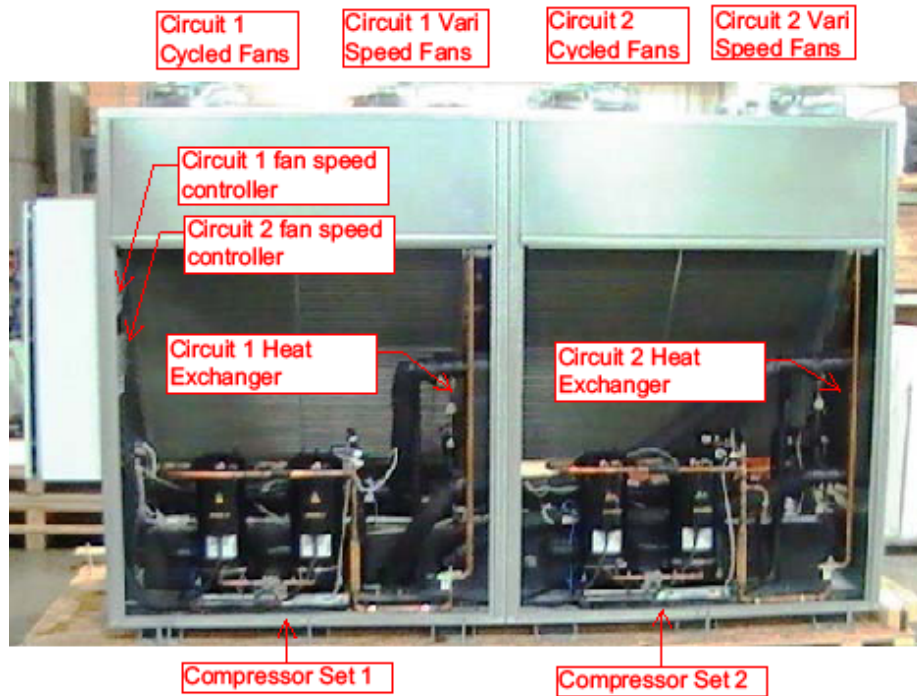

Heat Exchanger Overview 1

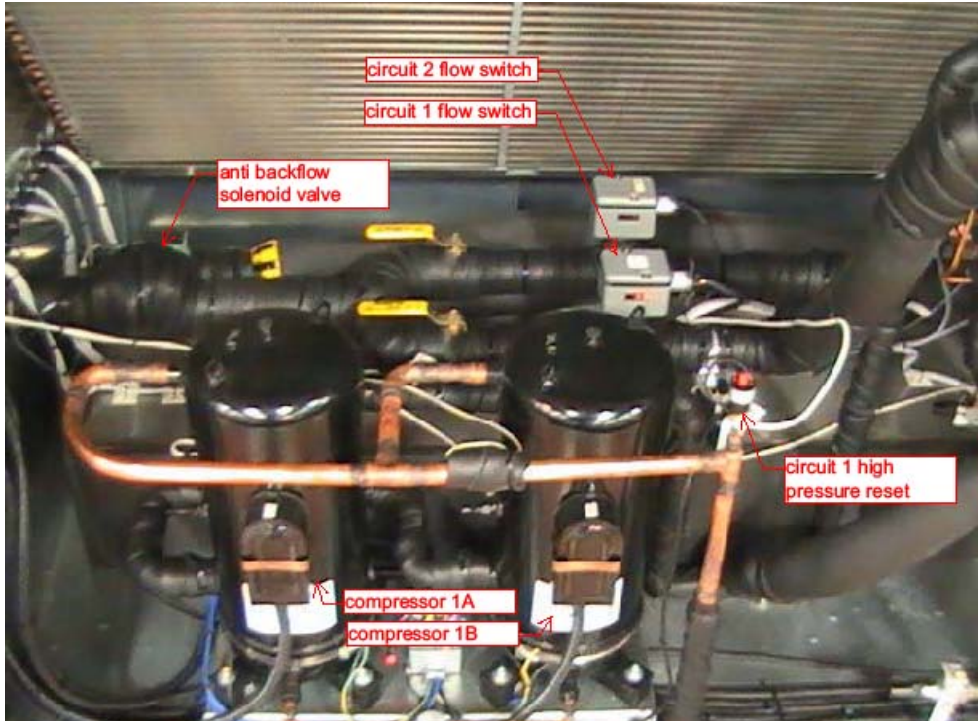

Compressor Set 1



Compressor Set 2



Pumps 1

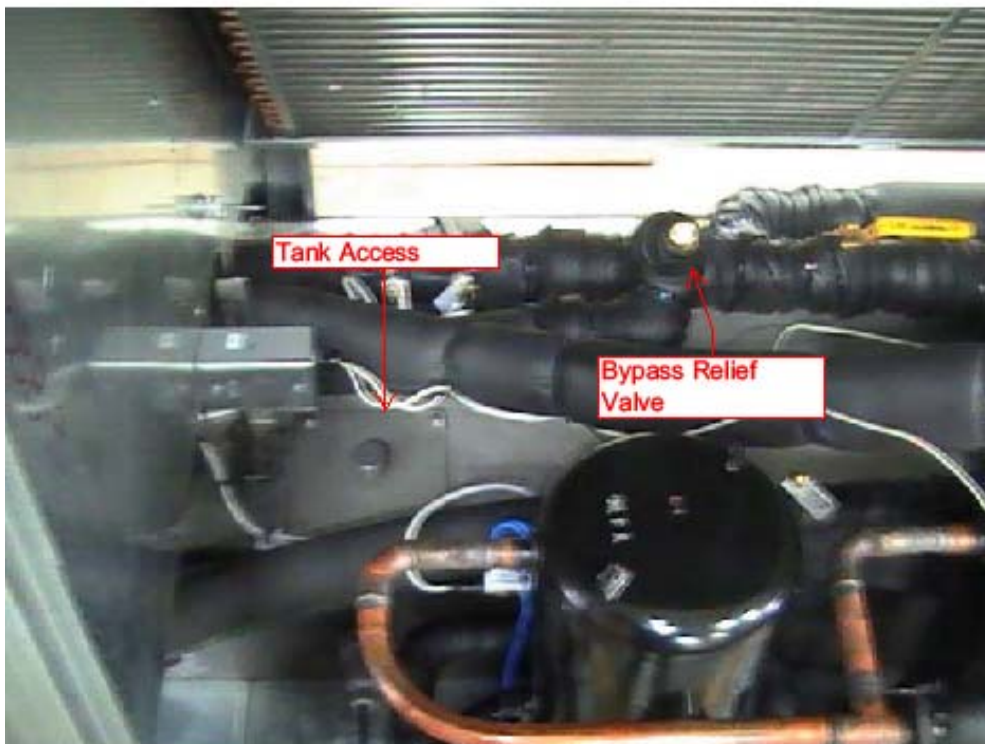

Tanks Access 1

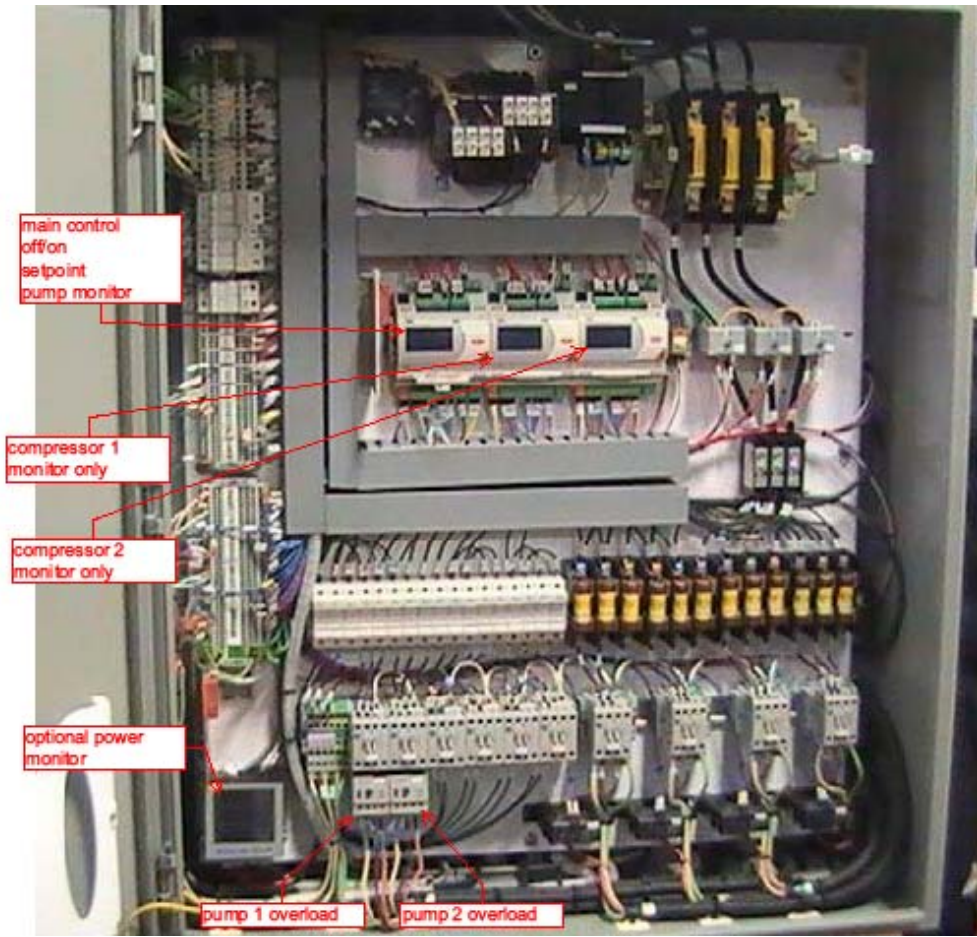

Electrical Panel 1

Article V. WATER TREATMENT

Dimplex Thermal Solutions recommends that an inhibited ethylene glycol or inhibited propylene glycol solution be used in its Heat Exchangers. Inhibited glycol solutions will prevent rust in ferrous material systems and it will keep algae and bacteria from growing inside the system. Use 40-50% glycol for freeze protection. If low toxicity glycol is desired or required, use an inhibited propylene glycol⁷.



CAUTION: Do not mix brand names or types of glycol as this may result in the inhibitors precipitating out of solution. Do not use automotive antifreeze in the Heat Exchanger unit as it can cause extensive damage to the cooling system. The use of automotive anti-freeze can affect the heat transfer of the system, fluid flow, and attack the pump seals.



CAUTION: Galvanized piping is not recommended because the zinc will react with the inhibitor in the fluids, causing precipitate formation, depletion of the inhibitor package, and removal of the protective zinc coating, particularly above 100°F. Precipitation can also lead to localized corrosion.



Dimplex Thermal Solutions offers its own brands of inhibited ethylene glycol called “K-Kool E” and inhibited propylene glycol “K-Kool P” as a service to its customers. Call 1-800-968-5665 (1-800-YOU-KOOL) and ask for the parts department for more information.

If you have any other questions regarding the use of glycol or other water treatment issues for your Dimplex Thermal Solutions Heat Exchanger, please contact the factory at 1-800-968-5665 and ask for the service department.

⁷ Always refer to the original equipment manufacturers water quality treatment requirements to which the Heat Exchanger is connected before treating water.

Article VI. MAINTENANCE

The following maintenance procedures should be completed every 4 - 6 months:

Section 6.01 Condenser: Cleaning Air Filters and Condenser



In order for the refrigeration system to perform to its rated capacity, it is very important to keep the condensing temperature from getting too hot. This usually happens when the condenser is not kept properly cleaned. The air cooled condensers are supplied with cleanable aluminum air filters, and it is very important that they be cleaned as necessary to maintain good airflow. Failing to do so will result in poor unit performance and possible compressor damage.

To clean the filters use a brush, compressed air or wash out with water. To clean the condenser coil using compressed air, pressure must not exceed 30 psi. Blow air in the opposite direction of the air flow when Heat Exchanger is in operation.

Section 6.02 Electric Motors

Maintenance for electric motors is required only when these motors are furnished with grease fittings so they can be greased. If this is the situation, we recommend greasing every 6 months.

Section 6.03 Check Water Quality / Test Glycol Mixture

System fluid should be clean and free of contaminants. Check the inlet and outlet pressure on the unit for normal pressures. These can be found under the "**HEAT EXCHANGER SPECIFICATIONS**" section. Test the glycol concentration level to ensure levels are within the rated conditions. Refill tank as needed with pre-mixed glycol to maintain proper concentration.

Section 6.04 Inspect and Clean Fluid Strainer

Fluid Strainers protect the brazed plate heat exchangers from becoming clogged. Inspect and clean strainers after first hour of operation, after first week of operation, and annually thereafter.



Section 6.05 Inspect Fluid System for Leaks or Loose Connection

Visually check fluid connections for any potential leaks in the system. Ensure there are no plumbing parts that show any significant wear including chaffing or cracking.

Section 6.06 Check All Wiring for Loose Connections, Chaffing or Damage

Turn off the main disconnect. Check all wiring inside of electrical panel and inside the Heat Exchanger unit for loose or damaged wires. Tighten any loose terminals and replace any damaged wires.

	WO2-2-5000-2P-NF-L-M-R407C 460 volt	WO2-2-7500-2P-NF-L-M-R407C 460 volt
Pump/fan contactor power term.	22 lb-in	22 lb-in
Pump contactor overload term.	12 lb -in	12 lb -in
Pump/fan contactor control term.	8.9 to 13 lb-in	8.9 to 13 lb-in
Pump overload power terminals	22 lb-in	22 lb-in
Pump overload control term.	5 lb-in	5 lb-in
Compressor contactor power	13.3 to 22 lb-in	13.3 to 22 lb -in
Compressor contactor control	8.9 to 13 lb-in	8.9 to 13 lb-in
Fused terminal	25 lb-in	25 lb-in
Disconnect wire terminal	35 lb-in	35 lb-in
Disconnect fuse screw	35 lb-in	35 lb-in
Disconnect shaft set screw	12 lb-in	12 lb-in
Fuse block terminal	35 lb-in	35 lb-in
Transformer Allen Bradley	10 lb-in	10 lb-in
Transformer Dongan	16-18 lb-in	16-18 lb-in
Power Dist. Block Primary	120 lb-in	120 lb-in
Power Dist. Block Secondary #8	25 lb-in	25 lb-in
Power Dist. Block Sec #10-#14	20 lb-in	20 lb-in
Control relay socket terminals	5-9 lb-in	5-9 lb-in
Controller plug screws- large	5 lb-in	5 lb-in
Controller plug screws- small	2 lb-in	2 lb-in

Section 6.07 Inspect and Test Refrigeration System for Leaks

Inspect the inside of the Heat Exchanger unit for any visual evidence of a refrigerant leak. Spots of oil on the inside of the unit or on the refrigeration lines may signify a potential leak. Have a certified refrigeration technician inspect the unit for proper operation.

Maintenance as you can see is minimal, but should you have a problem or situation not described above, please call our service department for assistance at (269) 349-6800.

Article VII. HEAT EXCHANGER SPECIFICATIONS

Model Number:	WO2-2-5000	WO2-2-7500
Capacity		
	14 Tons	20 Tons
@ 50°F Fluid	167,300 BTU/hr	240,000 BTU/hr
@ 122°F Ambient	49kW	70 KW
Dimensions		
Height:	85"	85"
Width:	44"	44"
Depth:	138"	138"
Mechanical		
Compressor:	5 hp x 4	7.5 hp x 4
Pump:	3 hp x 2	3 hp x 2
Fan:	½ hp x 4	½ hp x 8
Inlet:	2" NPTF	2" NPTF
Outlet:	2" NPTF	2" NPTF
Reservoir:	100 gallons	100 gallons
Weight:	3200 lbs - dry 4000lbs - operation	3500 lbs - dry 4300 lbs - operation
Electrical		
Voltage:	460V(+/-10%)/3/60Hz (+/-2Hz)	460V (+/-10%)/3/60Hz (+/-2Hz)
Voltage Imbalance	+/- 2 % max	+/- 2 % max
Disconnect Fuse:	80A	100A
FLA:	67A	91A
Compressor FLA:	11.8A	17.3A
Compressor LRA:	68A	114A
Pump FLA:	6.3A	6.3A
Fan FLA:	1.2A	1.2A
Max. Overcurrent Protect.	80A	110A
Min. Circuit Ampacity	70A	95A
Listings		
	NRTL LISTED TO UL1995(Standard) CUL 1995 (Canadian Sites)	NRTL LISTED TO UL1995(Standard) CUL 1995 (Canadian Sites)

Nominal flow required is 35 gpm @ 70 psi pump outlet, flow setter valve on fluid outlet pipe will automatically drop pressure to reduce flow to 35 gpm. Bypass relief valve is adjusted to maintain 70 to 80 psi maximum pressure to prevent pump damage due to deadheading. Bypass relief valve should only be adjusted to a higher pressure if the MRI is located above the Heat Exchanger. Increase valve setting by the head above the Heat Exchanger.

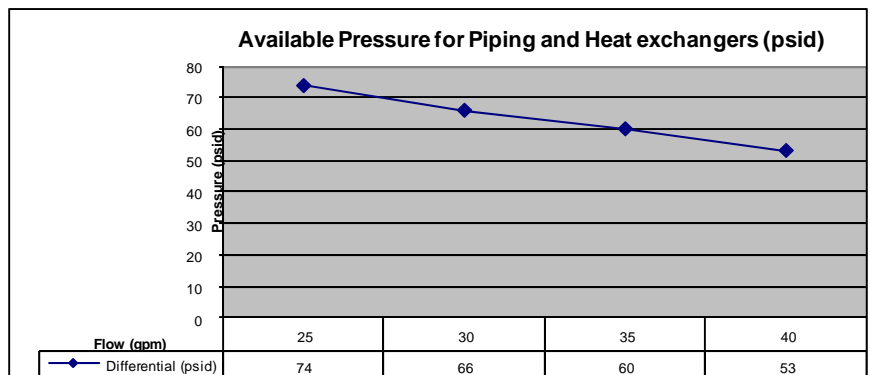

Article VIII. TROUBLESHOOTING SERVICE GUIDE

SYMPTOMS	POSSIBLE CAUSE
Selector switch is in "ON" position & pump will not start.	<ol style="list-style-type: none"> 1. Open disconnect switch 2. Blown fuse 3. Tripped overloads 4. Phase monitor fault 5. Low tank level
Pump is rotating but no pressure is established.	<ol style="list-style-type: none"> 1. Improper rotation 2. No water in reservoir 3. Valves not open 4. No back pressure 5. Pump suction blocked 6. Pump seal leaking
Pump runs properly, but compressor does not start.	<ol style="list-style-type: none"> 1. Compressor is not getting energized-flow switch not activated
Compressor hums but will not start.	<ol style="list-style-type: none"> 1. Low line voltage 2. Motor windings shorted to ground 3. Internal compressor damage 4. Improperly wired
Compressor will not start (no hum).	<ol style="list-style-type: none"> 1. Open disconnect or blown fuse 2. Thermal overload open 3. Relay not closing to start compressor 4. Bad motor windings 5. Loss of refrigerant charge
Compressor starts but trips on internal protector	<ol style="list-style-type: none"> 1. High suction or discharge pressure 2. Low line voltage 3. Bad motor windings
The unit short cycles.	<ol style="list-style-type: none"> 1. Low refrigerant charge 2. Defective expansion valve
Temperature controller is indicating a fault:	See Below:
High refrigerant pressure fault	<ol style="list-style-type: none"> 1. Dirty air filters 2. Refrigerant overcharge 3. Dirty condenser 4. Malfunction of fan motor 5. Excessive ambient air temperature
Low refrigerant pressure fault	<ol style="list-style-type: none"> 1. Extreme low ambient temperature 2. Refrigerant leak 3. Lack of fluid flow through heat exchanger 4. Liquid line solenoid valve stuck or not opening 5. Expansion valve stuck or lost bulbwell charge.
Fluid flow fault	<ol style="list-style-type: none"> 1. Pump not running 2. System not completely filled 3. Air in the system 4. Flow switch paddle stuck
Pump Overload fault	<ol style="list-style-type: none"> 1. Overload setting incorrect 2. Bad motor windings 3. Low pump pressure due to low piping resistance
Phase Monitor fault	<ol style="list-style-type: none"> 1. Incorrect line phasing 2. Low/High incoming voltage 3. Voltage imbalance between phases
Low Tank Level fault	<ol style="list-style-type: none"> 1. Low/no fluid in Heat Exchanger reservoir 2. Float switch stuck in the open position

Article IX. SPARE PARTS GUIDE

Detailed below is the recommended spare parts list for your Koolant Coolers Heat Exchanger. For current pricing on the parts listed, please contact the Dimplex Thermal Solutions parts department at (800) 968-5665.



DTS Guarantee: If any part purchased from this list fails to function within one year of the purchase date, due to a failure in the part, Dimplex Thermal Solutions will replace the stock part for no charge.

Koolant Coolers Model #: WO2-2-5000		
Part Description:	DTS PART	
	#:	Qty:
*Air Filters	4300142	4
*Expansion Valve	2760105	1
*Fan Motor	4051311	1
*Pump	1785007	1
*Pump Seal Kit	1785052	1
*Temperature Controller	4807776	1
*Temperature Sensor	0611318	1
Compressor	1450064	1
Crank Case Heater	1298032	1
Solenoid Valve	2710006	1
Solenoid Coil	0608319	1
Flow Switch	3653015	1
Pressure Transducer	4807736	1
Cord Set for Transducer	4807715	1
Pressure Transducer	4807739	1
Filter Dryer	2730006	1
Hi Pressure Switch	3640017	1
Lo Pressure Switch	3640006	1
ATJ80 Fuse	3500919	3
ATDR3 Fuse	3500970	3
TRM10 Fuse	3500091	2
TRM3 Fuse	3500030	1
ATDR1-1/2 Fuse	3500972	2
ATDR ½ Fuse	3500973	4
ATDR15 Fuse	3500960	10
AJT20 Fuse	3500910	12
*Core Components		

Koolant Coolers Model #: WO2-2-7500		
Part Description:	DTS PART	
	#:	Qty:
*Air Filters	4300142	4
*Expansion Valve	2760112	1
*Fan Motor	4051311	1
*Pump	1785007	1
*Pump Seal Kit	1785052	1
*Temperature Controller	4807776	1
*Temperature Sensor	0611318	1
Compressor	1450077	1
Crank Case Heater	1298032	1
Solenoid Valve	2710008	1
Solenoid Coil	0608319	1
Flow Switch	3653015	1
Pressure Transducer	4807736	1
Cord Set for Transducer	4807715	1
Pressure Transducer	4807739	1
Filter Dryer	2730005	1
Hi Pressure Switch	3640017	1
Lo Pressure Switch	3640006	1
ATJ100	3500921	3
ATDR3 Fuse	3500970	3
TRM10 Fuse	3500091	2
TRM3 Fuse	3500030	1
ATDR1-1/2 Fuse	3500972	2
ATDR ½ Fuse	3500973	4
ATDR15 Fuse	3500960	10
AJT25 Fuse	3500911	12
*Core Components		



MSDS & COMPONENT INFORMATION





APPLICATION FOR PREAPPROVAL SPECIAL SEISMIC CERTIFICATION OF EQUIPMENT AND COMPONENTS

For Office Use Only

APPLICATION NO.
OSP – 0169 – 10

Check whether application is: NEW RENEWAL

1.0 **DIMPLEX THERMAL SOLUTIONS** Doug Mathews
Manufacturer *Manufacturer's Technical Representative*

2625 Emerald Drive, Kalamazoo, MI 49001-4542
Mailing Address

(800) 968-5665
Telephone

dmathews@dimplexthermal.com
E-mail Address

2.0 **KOOLANT KOOLERS CHILLERS** Air cooled condensing process chillers
Product Name *Product Type*

See Attachment # 1

Product model No (List all unique product identification numbers and/or serial numbers)

General Description: These are cataloged, air cooled condensing process chillers acceptable for indoor or outdoor use. Cabinets may be constructed of either galvanized steel or stainless steel and meet NEMA 4 enclosure rating. Reservoir tanks shall be constructed with stainless steel. All units shall include modification to standard units incorporated in the test units.

3.0 **EQUIPMENTANCHORAGE.COM** JONATHAN ROBERSON, S.E.
Applicant Company Name *Contact Person*

5877 Pine Ave, Suite 210, Chino Hills, CA. 91709
Mailing Address

Mailing Address

(406) 541-EASE (3273)
Telephone

jon@easeco.com
E-mail Address

I hereby agree to reimburse the Office of Statewide Health Planning and Development for the actual costs incurred by the department for review.

Signature of Applicant

Date

SENIOR ENGINEER
Title

EQUIPMENTANCHORAGE.COM
Company Name

1/12



Registered Design Professional Preparing the Report
EQUIPMENTANCHORAGE.COM

4.0

Company Name

Jonathan Roberson, S.E.

S4197

Contact Name

California License Number

5877 Pine Ave, Suite 210, Chino Hills, CA. 91709

Mailing Address

909-606-7622

jon@easeco.com

Telephone

E-mail Address

California Licensed Structural Engineer Review and Acceptance of the Report
EQUIPMENTANCHORAGE.COM

5.0

Company Name

Jonathan Roberson, S.E.

S4197

Contact Name

California License Number

5877 Pine Ave, Suite 210, Chino Hills, CA. 91709

Mailing Address

909-606-7622

jon@easeco.com

Telephone

E-mail Address

Anchorage Pre-Approval

6.0

- Anchorage is pre-approved under OPA-
(Separate application for anchorage pre-approval is required)
- Anchorage is not Pre-approved **See Attachment 1**

Certification Method

7.0

- Testing in accordance with:
 - ICC-ES AC-156
 - Other (Please Specify):

- Analysis
- Experience data
- Combination of Testing, Analysis, and/or Experience Data (Please Specify):

Testing Laboratory (if applicable)

8.0

Environmental Testing Laboratory, Inc.

Brady Richard

Company Name

Contact Name

11034 Indian Trail, Dallas, TX 75229-3513

Mailing Address

972-247-9657

brady@etidallas.com

Telephone

E-mail:

2/12



Approval Parameters

9.0 Design in accordance with ASCE 7-05 Chapter 13: Yes No

Design Basis of Equipment or Components (F_p/W_p) = **4.73g (Spring Isolators); 1.44g (Rigid Base)**
 S_{DS} (Spectral response acceleration at short period) = **2.1g (3 Ton Models); 2.0g (All Others)**
 a_p (In-structure equipment or component amplification factor) = **2.5 (Spring Isolator); 1.0 (Rigid Base)**
 R_p (Equipment or component response modification factor) = **2.0 (Spring Isolator); 2.5 (Rigid Base)**
 I_p (Importance factor) = **1.5**
 z/h (Height factor ratio) = **1.0**
 Equipment or Component fundamental period(s) = **See Attachment 1**
 Building period limits (if any) = **None**
 Overall dimensions and weight (or range thereof) = **See Attachment 1**

Equipment or Components @ grade designed in accordance with ASCE 7-05 Chapter 15: Yes No

Design Basis of Equipment or Components (V/W) =
 S_{DS} (Spectral response acceleration at short period) =
 S_1 (Spectral response acceleration at 1 second period) =
 R (Response modification coefficient) = 1.0
 Ω_0 (System overstrength factor) = 1.0
 C_d (Deflection amplification factor) = 1.0
 I_p (Importance factor) = 1.5
 Height to Center of Gravity above base =
 Equipment or Component fundamental period(s) = Sec
 Overall dimensions and weight (or range thereof) =

Tank(s) designed in accordance with ASME BPVC, 2007: Yes No

10.0 List of attachments supporting the special seismic certification of equipment or components:

- Test Report Drawings Manufacturer's Catalog
 Calculations Others (Please Specify): **Attachment 1**

11.0 OSHPD Approval (For Office Use Only)

Chris Tokas
 Signature & Date

4/25/2011

December 31, 2016

Chris Tokas, SHFR
 Name & Title

Approval Expiration Date

S_{DS} (g) = **See Section 9.0** z/h = **1.0**

Condition of Approval (if any):

Special Seismic Certification Valid Up to

3/12

DIMPLEX THERMAL SOLUTIONS

SPECIAL SEISMIC CERTIFICATION OF CHILLER SYSTEMS



ATTACHMENT 1: KOOLANT KOOLER CHILLERS

Thermal Solutions

TABLE 1: SEISMIC CERTIFIED COMPONENTS

DIMPLEX THERMAL SOLUTIONS KOOLANT KOOLER CHILLER MODEL ¹	WIDTH (IN)	DEPTH (IN)	HEIGHT (IN)	DRY WT (LBS)	MOUNTING ²	BASIS
WO3000-NF-L-M-407C 3 Ton Chiller	50	28 1/2	65.25	730	Rigid Base	UUT1
					Spring Isolated	UUT2
WO3000-NF-L-M-407C-HA 3 Ton Chiller High Ambient	50	28 1/2	65.25	730	Rigid Base	Interpolated
					Spring Isolated	
WO5000-NF-L-M-407C 5 Ton Chiller	60	37.75	65.25	900	Rigid Base	Interpolated
					Spring Isolated	
WO7500-NF-L-M-407C 7.5 Ton Chiller	60	37.75	65.25	935	Rigid Base	Interpolated
					Spring Isolated	
WO2-5000-2P-NF-L-M-407C 10 Ton Chiller	109	34.4	76.25	2000	Rigid Base	Interpolated
					Spring Isolated	
WO2-7500-2P-NF-L-M-407C 15 Ton Chiller	109	34.4	76.25	2000	Rigid Base	UUT3
					Spring Isolated	UUT4
WO2-2-5000-2P-NF-L-M-407C 20 Ton Chiller	135	44.25	88.5	3500	Rigid Base	Interpolated
WO2-2-7500-2P-NF-L-M-407C 30 Ton Chiller	135	44.25	88.5	4000	Rigid Base	UUT5
Carel pGD Remote Display	6.1	1.2	3.2	< 1	Wall Mounted	UUT6

NOTES:

- Materials:** Components are seismically certified with either standard (galvanized carbon steel) or coastal (stainless steel) construction.
- Mounting:** Establishes the general mounting type(s) under which the tabulated components are seismically certified.
 - Rigid Base:** a free-standing, base mounted condition with direct connection between unit base and supporting structure.
 - Spring Isolated:** a free-standing, base mounted condition with spring isolators positioned between the equipment and supporting structure.
 - Wall Mounted:** a condition in which component is fully supported by a wall structure.
- Subassemblies:** Units are seismically certified with the subassemblies listed in Table 3 below.

TABLE 2: OSHPD ANCHORAGE PRE-APPROVALS (OPA)

COMPONENT	OPA NO.	APPROVAL STATUS
Koolant Kooler WO Series Chillers	OPA-2668-10	PENDING
Koolant Kooler WO Series Chillers w/ Isolators	OPA-2669-10	PENDING

DIMPLEX THERMAL SOLUTIONS SPECIAL SEISMIC CERTIFICATION OF CHILLER SYSTEMS



ATTACHMENT 1: KOOLANT KOOLER CHILLERS

Thermal Solutions

TABLE 3: CHILLER SUBASSEMBLIES ACCEPTED IN SEISMIC CERTIFICATION

MANUFACTURER	PRODUCT SERIES	MODEL	MAX. DIMENSIONS (MM)				MAX. WT. (KG)	MOUNT	NOTES
			DIAM	LENGTH	WIDTH	HEIGHT			
COMPRESSORS									
Sanyo	Scroll 3 Ton, 3.5 HP, 2.6KW	C-SBN263H8A	176	238	238	451	37.0	Inside Unit	UUT1, UUT2
Sanyo	Scroll 5.0 Ton, 6.0 HP, 4.5KW	C-SBN453H8G	176	238	238	451	39.0	Inside Unit	
Sanyo	Scroll 7.5 Ton, 8.0HP, 6.0KW	C-SCN603H8K	209	282	274	538	67.0	Inside Unit	UUT3, UUT4 UUT5, UUT6
Sanyo	Scroll 10.0 Ton, 10.0HP, 7.5KW	C-SCN753H8K	209	282	274	553	71.0	Inside Unit	
PUMP									
Walrus	3/4 HP	TPHK2T5-5S	---	231	180	426	12.7	Inside Unit	
Walrus	1-1/2 HP	TPHK4T5-5S	---	231	180	471	13.9	Inside Unit	UUT1, UUT2 UUT3, UUT4
Walrus	2 HP	TPHK4T7-7S	---	231	180	563	14.6	Inside Unit	
Walrus	1-1/2 HP	TPHK8T6-3S	---	246	200	568	24.3	Inside Unit	
Walrus	3 HP	TPHK8T6-5S	---	246	200	568	28.0	Inside Unit	UUT5, UUT6
FAN MOTOR									
Marathon	1/2 HP	048A170F1H	144	203	---	---	7.0	Inside Unit	ALL UUT
FAN BLADE									
Lau	16 inch	61146601	406	57	---	---	1.1	Inside Unit	UUT5, UUT6
Lau	18 inch	61142601	457	64	---	---	0.9	Inside Unit	UUT1, UUT2 UUT3, UUT4
HEAT EXCHANGER									
Kaori	Brazed Plate Heat Exchanger	K095x20	---	106	58	522	7.5	Inside Unit	UUT1, UUT2
Kaori	Brazed Plate Heat Exchanger	K095x30B	---	106	82	522	9.7	Inside Unit	
Kaori	Brazed Plate Heat Exchanger	K105x40B	---	124	106	504	13.1	Inside Unit	UUT3, UUT4
Kaori	Brazed Plate Heat Exchanger	K105x50B	---	124	130	504	15.5	Inside Unit	
Kaori	Brazed Plate Heat Exchanger	K205x30C	---	246	84	528	22.8	Inside Unit	
Kaori	Brazed Plate Heat Exchanger	K205x40C	---	246	108	528	28.0	Inside Unit	UUT5, UUT6
CONDENSER									
Keeprite	3-6 Ton	1413015	---	1010	870	70	55	Inside Unit	UUT1, UUT2
Keeprite	5 Ton	1413105	---	970	810	100	58	Inside Unit	
Keeprite	7.5-10 Ton	1413016	---	1260	1070	100	65	Inside Unit	UUT3, UUT4
Keeprite	20 Ton	1413086	---	1540	1520	100	120	Inside Unit	UUT5, UUT6

5/12



DIMPLEX THERMAL SOLUTIONS
SPECIAL SEISMIC CERTIFICATION OF CHILLER SYSTEMS



ATTACHMENT 1: KOOLANT KOOLER CHILLERS

Thermal Solutions

TABLE 3: CHILLER SUBASSEMBLIES ACCEPTED IN SEISMIC CERTIFICATION

MANUFACTURER	PRODUCT SERIES	MODEL	MAX. DIMENSIONS (MM)				MAX. WT. (KG)	MOUNT	NOTES
			DIAM	LENGTH	WIDTH	HEIGHT			
FLOW SWITCH									
Johnson Controls		F61MB-1C	---	95	70	220	0.9	Inside Unit	ALL UUT
LOW FLUID TANK LEVEL INDICATOR									
Harwil	Liquid Level Switch	L-21N-11A-1-B	---	52	45	263	0.2	Inside Unit	UUT5, UUT6 UUT3, UUT4
Harwil	Liquid Level Switch	L-21N-11A-2-F-25	---	52	45	263	0.2	Inside Unit	UUT1, UUT2
Harwil	Liquid Level Switch	L-21N-11A-2-B-25	---	52	45	263	0.2	Inside Unit	
PRESSURE RELIEF BYPASS VALVE									
Aquatrol	Series 69 1-1/4", 35-100 PSI	D1DX70	---	89	74	220	2.0	Inside Unit	UUT5, UUT6 UUT3, UUT4
Aquatrol	Series 69 1", 35-100 PSI	C1DX70	---	76	64	190	1.4	Inside Unit	
Spraying Systems	3/4", 300 PSI	6815G-3/4- HSS-300	---	51	34	152	0.6	Inside Unit	UUT1, UUT2
ANTI-BACKFLOW KIT									
Asco	Solenoid Valve 1"	8210G027 8210G004 8210G054	---	95	85	143	2.0	Inside Unit	UUT1, UUT2
Asco	Solenoid Valve 1-1/4"	8210G008	---	93	90	143	2.5	Inside Unit	
Asco	Solenoid Valve 1-1/2"	8210G056	---	111	90	150	2.6	Inside Unit	UUT3, UUT4
Asco	Solenoid Valve 2"	8210G100	---	129	124	186	4.0	Inside Unit	UUT5, UUT6
Watts	Check Valve 1", Series 600	0376354	50	79	---	---	0.6	Inside Unit	UUT1, UUT2
Watts	Check Valve 1-1/4" Series 600	0376355	64	95	---	---	1.0	Inside Unit	
Watts	Check Valve 1-1/2" Series 600	0376356	70	102	---	---	1.4	Inside Unit	UUT3, UUT4
Watts	Check Valve 2" Series 600	0376357	89	114	---	---	2.0	Inside Unit	UUT5, UUT6
CONTROLLER									
Carel		pCO1	---	114	60	140	0.4	Inside Unit	ALL UUT
Johnson Controls	Condenser Fan Speed Control	P266	---	159	70	177	1.0	Inside Unit	ALL UUT

6/12

DIMPLEX THERMAL SOLUTIONS
SPECIAL SEISMIC CERTIFICATION OF CHILLER SYSTEMS
ATTACHMENT 1: KOOLANT KOOLER CHILLERS



UUT-1: 3 TON CHILLER

- NAME:** 3 Ton Chiller (WO 3000)
- MANUFACTURER:** Dimplex Thermal Solutions
- UUT FUNCTION:** Air-cooled condensing process chillers for indoor or outdoor use.
- DESCRIPTION:** Single Refrigeration Circuit & Single Fluid Circuit
 Compliant with UL1995 standards
 Controller: Carel PCOxs
 Compressor : (1) Sanyo C-SBN263H8A 2 Ton
 Pump : (1) Walrus TPHPK4T5-5S 2.0 kW
 Fan Motor: (1) ½ HP Marathon 048A170F1H
 Fan Blade: (1) 18-in Lau 61142601
 Heat Exchanger: (1) Kaori K095x20
 Condensor: (1) Heatcraft 3-6 Ton
 Refrigerant: 407c
 Cabinet: Stainless Steel NEMA 4 electrical enclosure,
 Tank: 40 gallon, Stainless Steel, Sealed w/ air vent
 Anti-backflow kit, pressure relief bypass valve, flow switch, & Low fluid tank level indicator
- IDENTIFICATION:** Model No.: WO-3000-NF-L-M-407C; Serial No.: 31457
- DIMENSIONS:** 51" W x 27.5" D x 60.75" H
- WEIGHT:** 685 (Dry) / 1100 lbs (Operating)
- RESTRICTIONS:** STANDARD AMBIENT RANGE -20° TO +105° F (-29° to +40° C)
- MOUNTING:** RIGID BASE: (4)-½" dia. Grade 5 bolts to steel table extension

LOWEST RESONANT FREQUENCY:	<u>F/B AXIS</u>	<u>S/S AXIS</u>	<u>VERT AXIS</u>	<u>OFF-AXIS</u>
	5.8	3.3	10.8	2.8



Dimplex Thermal Solutions
 2625 Emerald Drive
 Kalamazoo, Michigan 49001-4542
 Phone: (269) 349-6800 Fax: 349-8951

Model: WO 3,000-NF-L-M-407C
 Serial: 31457

	H.P.	FLA(Amps)	LRA(Amps)
1 Compressor	3	6.9	43
1 Chiller Pump	2	4.8	
1 Fan	1/2	1.2	

Minimum Circuit Ampacity: 20 Amps
 Maximum Overcurrent Protection: 30 Amps

REFRIGERATION
 Refrigerant: R-407C
 Pounds: 9 Lbs
 Design Pressure
 High Side: 250 PSI Low Side: 80 PSI

Manufactured: November 2010
 Outdoor Use

WARNING: RISK OF ELECTRICAL SHOCK. CAN CAUSE INJURY OR DEATH. DISCONNECT ALL REMOTE ELECTRICAL POWER SUPPLIES BEFORE SERVICING.

7/12

DIMPLEX THERMAL SOLUTIONS
SPECIAL SEISMIC CERTIFICATION OF CHILLER SYSTEMS
ATTACHMENT 1: KOOLANT KOOLER CHILLERS



UUT-2: 3 TON CHILLER WITH ISOLATORS

- NAME:** 3 Ton Chiller (WO 3000) with Isolator
- MANUFACTURER:** Dimplex Thermal Solutions
- UUT FUNCTION:** Air-cooled condensing process chillers for indoor or outdoor use.
- DESCRIPTION:** Single Refrigeration Circuit & Single Fluid Circuit
 Compliant with UL1995 standards
 Controller: Carel PCOxs
 Compressor : (1) Sanyo C-SBN263H8A 2 Ton
 Pump : (1) Walrus TPK4T5-5S 2.0 kW
 Fan Motor: (1) ½ HP Marathon 048A170F1H
 Fan Blade: (1) 18-in Lau 61142601
 Heat Exchanger: (1) Kaori K095x20
 Condensor: (1) Heatcraft 3-6 Ton
 Refrigerant: 407c
 Cabinet: Stainless Steel NEMA 4 electrical enclosure, site glass/fill tube
 Tank: 40 gallon, Stainless Steel, Sealed w/ air vent
 Anti-backflow kit, pressure relief bypass valve, flow switch, & Low fluid tank level indicator
- IDENTIFICATION:** Model No.: WO-3000-NF-L-M-407C; Serial No.: 31457
- DIMENSIONS:** 51" W x 27.5" D x 60.75" H
- WEIGHT:** 685 (Dry) / 1100 lbs (Operating)
- RESTRICTIONS:** STANDARD AMBIENT RANGE -20° TO +105° F (-29° to +40° C)
- MOUNTING:** SPRING ISOLATED: (4)-Sundown Model No. VMSSM1 (1" deflection). Each isolator anchored w/ ½" dia. Grade 5 bolts to UUT and (2)-½" dia. Grade 5 bolts to steel table extension. (Isolators manufactured by Vimco Part No. SSMA-1-27)

LOWEST RESONANT FREQUENCY:	<u>F/B AXIS</u>	<u>S/S AXIS</u>	<u>VERT AXIS</u>	<u>OFF-AXIS</u>
	1.8	1.7	5.6	1.6



Dimplex Thermal Solutions
 2625 Emerald Drive
 Kalamazoo, Michigan 49001-4542
 Phone: (269) 349-6800 Fax: 349-8951

Model: WO 3,000-NF-L-M-407C
 Serial: 31457

460 VOLTS 3 PH 60Hz

	H.P.	FLA(Amps)	LRA(Amps)
1 Compressor	3	6.9	43
1 Chiller Pump	2	4.8	
1 Fan	1/2	1.2	

Minimum Circuit Ampacity: 20 Amps
 Maximum Overcurrent Protection: 30 Amps

REFRIGERATION
 Refrigerant: R-407C
 Pounds: 9 Lbs
 Design Pressure
 High Side: 250 PSI Low Side: 80 PSI

Manufactured: November 2010
 Outdoor Use
WARNING: RISK OF ELECTRICAL SHOCK. CAN CAUSE INJURY OR DEATH. DISCONNECT ALL REMOTE ELECTRICAL POWER SOURCES BEFORE SERVICING.

8/12

DIMPLEX THERMAL SOLUTIONS SPECIAL SEISMIC CERTIFICATION OF CHILLER SYSTEMS ATTACHMENT 1: KOOLANT KOOLER CHILLERS



UUT-3: 15 TON CHILLER

- NAME:** 15 Ton Chiller (WO2-7500)
MANUFACTURER: Dimplex Thermal Solutions
UUT FUNCTION: Air-cooled condensing process chillers for indoor or outdoor use.
DESCRIPTION: Dual, Independent Refrigeration Circuit; Dual, Redundant Fluid Circuit
Compliant with UL1995 standards
Controller: Carel PCOxs
Compressor : (2) 7.5 Ton Sanyo C-SCN603H8K
Pump : (2) 2.0 kW Walrus TPHK4T5-5S
Fan Motor: (4) ½ HP Marathon 048A170F1H
Fan Blade: (4) 18-in Lau 61142601
Heat Exchanger: (2) Kaori K105x40B
Condensor: (2) Heatcraft 7.5-10 Ton
Refrigerant: 407c
Cabinet: Galvanized steel NEMA 4 electrical enclosure, site glass/fill tube
Tank: 72 gallon, stainless steel, sealed w/ air vent tank.
Anti-backflow kit, pressure relief bypass valve, flow switch, & Low fluid tank level indicator
- IDENTIFICATION:** Model No.: WO2-7500-2P-NF-L-M-407C; Serial No.: 30940
- DIMENSIONS:** 109.125" W x 31.375" D x 76.875" H
- WEIGHT:** 3000 lbs (Operating)
- RESTRICTIONS:** AMBIENT RANGE -20° TO +120° F (-29° to +49° C)
- MOUNTING:** RIGID BASE: (8)-½" Dia. Grade 5 bolts (2 lines of 4 bolts each) to steel rails of table extension.

LOWEST RESONANT FREQUENCY:

F/B AXIS
5.5

S/S AXIS
5.3

VERT AXIS
10.2

OFF-AXIS
N/A

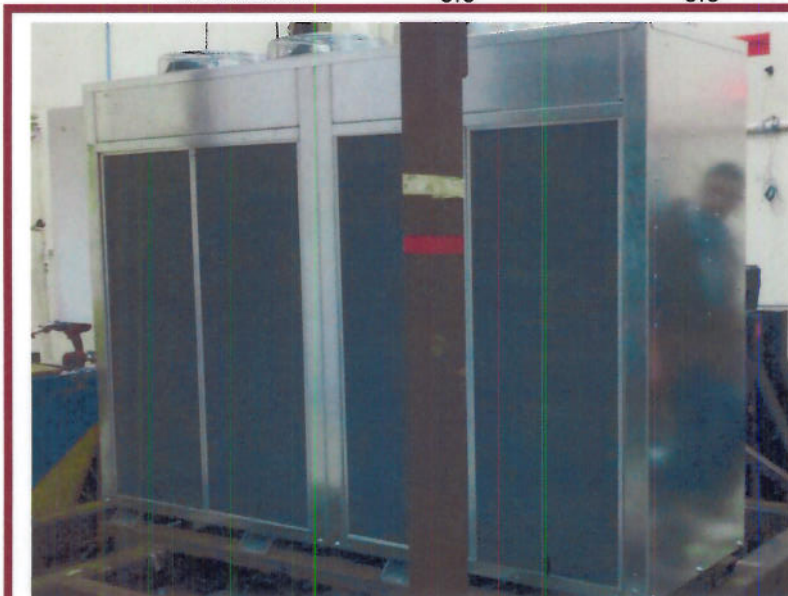

9/12

DIMPLEX THERMAL SOLUTIONS
SPECIAL SEISMIC CERTIFICATION OF CHILLER SYSTEMS
ATTACHMENT 1: KOOLANT KOOLER CHILLERS



UUT-4: 15 TON CHILLER ON ISOLATORS

- NAME:** 15 Ton Chiller (WO2-7500) on Isolators
- MANUFACTURER:** Dimplex Thermal Solutions
- UUT FUNCTION:** Air-cooled condensing process chillers for indoor or outdoor use.
- DESCRIPTION:** Dual, Independent Refrigeration Circuit; Dual, Redundant Fluid Circuit
 Single Refrigeration Circuit & Single Fluid Circuit
 Compliant with UL1995 standards
 Controller: Carel PCOxs
 Compressor : (2) 7.5 Ton Sanyo C-SCN603H8K
 Pump : (2) 2.0 kW Walrus TPK4T5-5S
 Fan Motor: (4) ½ HP Marathon 048A170F1H
 Fan Blade: (4) 18-in Lau 61142601
 Heat Exchanger: (2) Kaori K105x40B
 Condensor: (2) Heatcraft 7.5-10 Ton
 Refrigerant: 407c
 Cabinet: Galvanized steel NEMA 4 electrical enclosure, site glass/fill tube
 Tank: 72 gallon, stainless steel, sealed w/ air vent tank.
 Anti-backflow kit, pressure relief bypass valve, flow switch, & Low fluid tank level indicator
- IDENTIFICATION:** Model No.: WO2-7500-2P-NF-L-M-407C; Serial No.: 30940
- DIMENSIONS:** 109.125" W x 31.375" D x 76.875" H
- WEIGHT:** 3000 lbs (Operating)
- RESTRICTIONS:** AMBIENT RANGE -20° TO +120° F (-29° to +49° C)
- MOUNTING:** SPRING ISOLATED: (8) Mason SLRSO – B – 750 spring isolators [2 lines of 4 isolators along length of UUT] w/ (4) ½" Grade 5 bolts at top & bottom of each isolator.

**LOWEST RESONANT
 FREQUENCY:**

F/B AXIS
 2.4

S/S AXIS
 2.8

VERT AXIS
 5.7

OFF-AXIS
 N/A

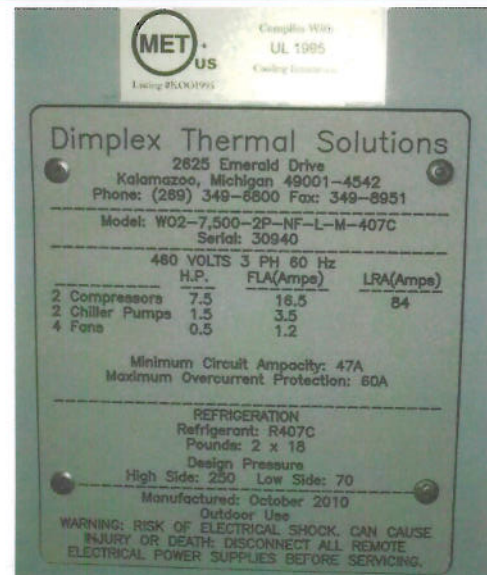

10/12

DIMPLEX THERMAL SOLUTIONS SPECIAL SEISMIC CERTIFICATION OF CHILLER SYSTEMS ATTACHMENT 1: KOOLANT KOOLER CHILLERS



UUT-5 : 30 TON CHILLER

- NAME:** 30 Ton Chiller (W02-2-7500)
- MANUFACTURER:** Dimplex Thermal Solution
- UUT FUNCTION:** Air-cooled condensing process chillers for indoor or outdoor use.
- DESCRIPTION:** Dual, Independent Refrigeration Circuit with tandem comps;
Dual, Redundant Fluid Circuit
Compliant with UL1995 standards
Controller: Carel PCOxs
Compressor : (4) 7.5 Ton Sanyo C-SCN603H8K
Pump : (2) 3.9 kW Walrus TPHPK8T6-5S
Fan Motor: (8) ½ HP Marathon 048A170F1H
Fan Blade: (8) 16-in Lau 61142601
Heat Exchanger: (2) Kaori K205x40C
Condenser: (2) Heatcraft 20 Ton
Refrigerant: 407c
Cabinet: Galvanized, NEMA 4 electrical enclosure, site glass/fill tube, V-coil cabinet configuration
Tank: 100 gallon, stainless steel, sealed with air-vent
Anti-backflow kit, pressure relief bypass valve, flow switch, & Low fluid tank level indicator
- IDENTIFICATION:** Model No.: W02-2-7500-2P-NF-L-M-407C; Serial No.: 31314
- DIMENSIONS:** 135" W x 41.5" D x 88.5" H
- WEIGHT:** 3926 lbs (Dry)
- RESTRICTIONS:** AMBIENT RANGE -20° TO +120° F (-29° to +49° C)
- MOUNTING:** RIGID BASE: (8) - ½" Grade 5 bolts (2 lines of 4 bolts each) to steel table extension.

**LOWEST RESONANT
FREQUENCY:**

F/B AXIS
5.8

S/S AXIS
3.0

VERT AXIS
7.5

OFF-AXIS
N/A



11/12

DIMPLEX THERMAL SOLUTIONS SPECIAL SEISMIC CERTIFICATION OF CHILLER SYSTEMS



ATTACHMENT 1: KOOLANT KOOLER CHILLERS

Thermal Solutions

UUT-6: Remote Display





The MSDS format adheres to the standards and regulatory requirements of the United States and may not meet regulatory requirements in other countries.

DuPont
Material Safety Data Sheet

Page 1

6037FR "SUVA" 407C
Revised 29-AUG-2001

CHEMICAL PRODUCT/COMPANY IDENTIFICATION

Material Identification

"SUVA" is a registered trademark of DuPont.

Corporate MSDS Number : DU005999

Tradenames and Synonyms

"SUVA" 9000

Company Identification

MANUFACTURER/DISTRIBUTOR

DuPont Fluoroproducts
1007 Market Street
Wilmington, DE 19898

PHONE NUMBERS

Product Information : 1-800-441-7515 (outside the U.S.
302-774-1000)
Transport Emergency : CHEMTREC 1-800-424-9300 (outside U.S.
703-527-3887)
Medical Emergency : 1-800-441-3637 (outside the U.S.
302-774-1000)

COMPOSITION/INFORMATION ON INGREDIENTS

Components

Material	CAS Number	%
PENTAFLUOROETHANE (HFC-125)	354-33-6	25
	811-97-2	
ETHANE, 1,1,1,2-TETRAFLUORO- (HFC-134a)		52
DIFLUOROMETHANE (HFC-32)	75-10-5	23

HAZARDS IDENTIFICATION

Potential Health Effects

Inhalation of high concentrations of vapor is harmful and may cause heart irregularities, unconsciousness, or death. Intentional misuse or deliberate inhalation may cause death without warning. Vapor reduces oxygen available for breathing and is heavier than air. Liquid contact can cause frostbite.

(HAZARDS IDENTIFICATION - Continued)

HUMAN HEALTH EFFECTS:

Overexposure to the vapors by inhalation may include temporary nervous system depression with anesthetic effects such as dizziness, headache, confusion, incoordination, and loss of consciousness. Higher exposures to the vapors may cause temporary alteration of the heart's electrical activity with irregular pulse, palpitations, or inadequate circulation. Gross overexposure may be fatal. Skin contact with the liquid may cause frostbite.

Individuals with preexisting diseases of the central nervous or cardiovascular system may have increased susceptibility to the toxicity of increased exposures.

Carcinogenicity Information

None of the components present in this material at concentrations equal to or greater than 0.1% are listed by IARC, NTP, OSHA or ACGIH as a carcinogen.

FIRST AID MEASURES

First Aid

INHALATION

If inhaled, immediately remove to fresh air. Keep person calm. If not breathing, give artificial respiration. If breathing is difficult, give oxygen. Call a physician.

SKIN CONTACT

Flush area with lukewarm water. Do not use hot water. If frostbite has occurred, call a physician.

EYE CONTACT

In case of contact, immediately flush eyes with plenty of water for at least 15 minutes. Call a physician.

INGESTION

Not a probable route. However, in case of accidental ingestion, call a physician.

Notes to Physicians

THIS MATERIAL MAY MAKE THE HEART MORE SUSCEPTIBLE TO ARRHYTHMIAS. Catecholamines such as adrenaline, and other compounds having similar effects, should be reserved for emergencies and then used only with special caution.

FIRE FIGHTING MEASURES

Flammable Properties

Flash Point : No flash point

Flammable Limits in Air, % by Volume:

LEL : None per ASTM E681

UEL : None per ASTM E681

Autoignition: Not determined

Fire and Explosion Hazards:

Cylinders may rupture under fire conditions. Decomposition may occur.

Contact of welding or soldering torch flame with high concentrations of refrigerant can result in visible changes in the size and color of torch flames. This flame effect will only occur in concentrations of product well above the recommended exposure limit, therefore stop all work and ventilate to disperse refrigerant vapors from the work area before using any open flames.

R-407C is not flammable in air at temperatures up to 100 deg C (212 deg F) at atmospheric pressure. However, mixtures of R-407C with high concentrations of air at elevated pressure and/or temperature can become combustible in the presence of an ignition source. R-407C can also become combustible in an oxygen enriched environment (oxygen concentrations greater than that in air). Whether a mixture containing R-407C and air, or R-407C in an oxygen enriched atmosphere becomes combustible depends on the inter-relationship of 1) the temperature 2) the pressure, and 3) the proportion of oxygen in the mixture. In general, R-407C should not be allowed to exist with air above atmospheric pressure or at high temperatures; or in an oxygen enriched environment. For example: R-407C should NOT be mixed with air under pressure for leak testing or other purposes.

Experimental data have also been reported which indicate combustibility of HFC-134a, a component in this blend, in the presence of chlorine.

Extinguishing Media

As appropriate for combustibles in area.

Fire Fighting Instructions

Cool cylinder with water spray or fog. Self-contained breathing apparatus (SCBA) is required if cylinders rupture and contents are released under fire conditions. Water runoff should be contained and neutralized prior to release.

ACCIDENTAL RELEASE MEASURES

Safeguards (Personnel)

NOTE: Review FIRE FIGHTING MEASURES and HANDLING (PERSONNEL) sections before proceeding with clean-up. Use appropriate PERSONAL PROTECTIVE EQUIPMENT during clean-up.

Accidental Release Measures

Ventilate area, especially low or enclosed places where heavy vapors might collect. Remove open flames. Use self-contained breathing apparatus (SCBA) for large spills or releases.

HANDLING AND STORAGE

Handling (Personnel)

Avoid breathing vapor. Avoid liquid contact with eyes and skin. Use with sufficient ventilation to keep employee exposure below recommended limits. Contact with chlorine or other strong oxidizing agents should also be avoided. See Fire and Explosion Data section.

Storage

Clean, dry area. Do not heat above 52 deg C (125 deg F).

EXPOSURE CONTROLS/PERSONAL PROTECTION

Engineering Controls

Avoid breathing vapors. Avoid contact with skin or eyes. Use with sufficient ventilation to keep employee exposure below the recommended exposure limit. Local exhaust should be used if large amounts are released. Mechanical ventilation should be used in low or enclosed places.

Personal Protective Equipment

Impervious gloves should be used to avoid prolonged or repeated exposure. Chemical splash goggles should be available for use as needed to prevent eye contact. Under normal manufacturing conditions, no respiratory protection is required when using this product. Self-contained breathing apparatus (SCBA) is required if a large release occurs.

Exposure Guidelines

Applicable Exposure Limits

PENTAFLUOROETHANE (HFC-125)

PEL (OSHA) : None Established
 TLV (ACGIH) : None Established
 AEL * (DuPont) : 1000 ppm, 8 & 12 Hr. TWA
 WEEL (AIHA) : 1000 ppm, 4900 mg/m³, 8 Hr. TWA

ETHANE, 1,1,1,2-TETRAFLUORO- (HFC-134a)

PEL (OSHA) : None Established
 TLV (ACGIH) : None Established
 AEL * (DuPont) : 1000 ppm, 8 & 12 Hr. TWA
 WEEL (AIHA) : 1000 ppm, 8 Hr. TWA

DIFLUOROMETHANE (HFC-32)

AEL * (DuPont) : 1000 ppm, 8 & 12 Hr. TWA
 WEEL (AIHA) : 1000 ppm, 8 Hr. TWA

* AEL is DuPont's Acceptable Exposure Limit. Where governmentally imposed occupational exposure limits which are lower than the AEL are in effect, such limits shall take precedence.

PHYSICAL AND CHEMICAL PROPERTIES

Physical Data

Boiling Point : -43.9 C (-47 F) Average
 Vapor Pressure : 171.8 psia 25 C (77 F)
 % Volatiles : 100 WT%
 Evaporation Rate : (Cl4 = 1)
 Greater than 1
 Solubility in Water : Not determined
 Odor : Slight ethereal
 Form : Liquefied gas
 Color : Clear, colorless
 Specific Gravity : 1.136 @ 25 C (77 F)

STABILITY AND REACTIVITY

Chemical Stability

Material is stable. However, avoid open flames and high temperatures.

Incompatibility with Other Materials

Incompatible with active metals, alkali or alkaline earth metals--powdered Al, Zn, Be, etc.

(STABILITY AND REACTIVITY - Continued)

Decomposition

Decomposition products are hazardous. "SUVA" 9000 can be decomposed by high temperatures (open flames, glowing metal surfaces, etc.) forming hydrochloric and hydrofluoric acids and possibly carbonyl halides. These materials are toxic and irritating. Contact should be avoided.

Polymerization

Polymerization will not occur.

TOXICOLOGICAL INFORMATION

Animal Data

The blend is untested.

HFC-125

Inhalation 4 hour ALC: > 709,000 ppm in rats

Single, high inhalation exposures caused lethargy, decreased activity, labored breathing and weight loss. Weak cardiac sensitization effect, a potentially fatal disturbance of heart rhythm caused by a heightened sensitivity to the action of epinephrine. Lowest-Observed-Adverse-Effect-Level for cardiac sensitization: 100,000 ppm. Repeated exposure caused: No significant toxicological effects. No-Observed-Adverse-Effect-Level (NOAEL): 50,000 ppm

No animal data are available to define carcinogenic, developmental or reproductive hazards. In animal testing this material has not caused developmental toxicity. HFC-125 does not produce genetic damage in bacterial or mammalian cell cultures or when tested in animals (not tested for heritable genetic damage).

HFC-134a

Inhalation 4-hour LC50: 567,000 ppm in rats

Single exposure caused: Cardiac sensitization, a potentially fatal disturbance of heart rhythm associated with a heightened sensitivity to the action of epinephrine. Lowest-Observed-Adverse-Effect-Level for cardiac sensitization: 75,000 ppm. Single exposure caused: Lethargy. Narcosis. Increased respiratory rates. These effects were temporary. Single exposure to near lethal doses caused: Pulmonary edema. Repeated exposure caused: Increased adrenals, liver, spleen weight. Decreased uterine, prostate weight. Repeated dosing of higher concentrations caused: the following temporary effects - Tremors. Incoordination.

(TOXICOLOGICAL INFORMATION - Continued)

CARCINOGENIC, DEVELOPMENTAL, REPRODUCTIVE, MUTAGENIC EFFECTS:

In a two-year inhalation study, HFC-134a, at a concentration of 50,000 ppm, produced an increase in late-occurring benign testicular tumors, testicular hyperplasia and testicular weight. The no-effect-level for this study was 10,000 ppm. Animal data show slight fetotoxicity but only at exposure levels producing other toxic effects in the adult animal. Reproductive data on male mice show: No change in reproductive performance. Tests have shown that this material does not cause genetic damage in bacterial or mammalian cell cultures, or in animals. In animal testing, this material has not caused permanent genetic damage in reproductive cells of mammals (has not produced heritable genetic damage).

HFC-32

Inhalation: 4 hour-ALC: > 520,000 ppm in rats

Single exposure caused: Lethargy. Spasms. Loss of mobility in the hind limbs. Other effects include weak cardiac sensitization, a potentially fatal disturbance of heart rhythm caused by a heightened sensitivity to the action of epinephrine. 250,000 ppm.

Repeated exposure caused pathological changes of the lungs, liver, spleen, kidneys. In more recent studies repeated exposure caused: No significant toxicological effects. No-Observed-Effect-Level (NOEL): 49,100 ppm.

No animal data are available to define the following effects of this material: carcinogenicity, reproductive toxicity. Animal data show slight fetotoxicity but only at exposure levels producing other toxic effects in the adult animal. Tests have shown that this material does not cause genetic damage in bacterial or mammalian cell cultures, or in animals. This material has not been tested for its ability to cause permanent genetic damage in reproductive cells of mammals (not tested for heritable genetic damage).

ECOLOGICAL INFORMATION

Ecotoxicological Information

HFC-134a

48-hour EC50, Daphnia magna: 980 mg/L
96-hour LC50, Rainbow trout: 450 mg/L

DISPOSAL CONSIDERATIONS

Waste Disposal

Comply with Federal, State, and local regulations. Reclaim by distillation or remove to a permitted waste disposal facility.

TRANSPORTATION INFORMATION

Shipping Information

DOT/IMO/IATA
Proper Shipping Name : Refrigerant Gas R407C
Hazard Class : 2.2
UN No. : 3340
Label(s) : Nonflammable Gas

Shipping Containers

Tank Cars.

Cylinders
Ton Tanks-----
REGULATORY INFORMATION

U.S. Federal Regulations

TSCA Inventory Status : Reported/Included.

TITLE III HAZARD CLASSIFICATIONS SECTIONS 311, 312

Acute : Yes
Chronic : Yes
Fire : No
Reactivity : No
Pressure : Yes

LISTS:

SARA Extremely Hazardous Substance -No
CERCLA Hazardous Substance -No
SARA Toxic Chemical -No

OTHER INFORMATION

NFPA, NPCA-HMIS

NPCA-HMIS Rating
Health : 1
Flammability : 0
Reactivity : 1

Personal Protection rating to be supplied by user depending on use conditions.

Additional Information

MEDICAL USE: CAUTION: Do not use in medical applications involving permanent implantation in the human body. For other medical applications see DuPont CAUTION Bulletin No. H-50102.

The data in this Material Safety Data Sheet relates only to the specific material designated herein and does not relate to use in combination with any other material or in any process.

Responsibility for MSDS : MSDS Coordinator
> : DuPont Fluoroproducts
Address : Wilmington, DE 19898
Telephone : (800) 441-7515

Indicates updated section.

This information is based upon technical information believed to be reliable. It is subject to revision as additional knowledge and experience is gained.

End of MSDS

Vi ringraziamo per la scelta fatta, sicuri che sarete soddisfatti del vostro acquisto.

Il display grafico pGD è un dispositivo elettronico, compatibile con i precedenti terminali della linea pCO(IPCOT che consente la completa gestione della grafica, tramite la visualizzazione di icone (definite a livello di sviluppo software applicativo) e la gestione di font in dimensioni di due dimensioni: 5x7 e 11x15 pixel. Il software applicativo è residente soltanto sulla scheda pCO. Il terminale non ha bisogno di nessun software aggiuntivo in fase di utilizzo. Inoltre il terminale offre un ampio range di temperatura di funzionamento (-20/60 °C) e nella versione ad incasso il frontale garantisce un elevato grado di protezione (IP65).

Codici dei modelli

Versione da incasso o pannello PGD0000F00
Versione da parete PGD0000W00

Montaggio a pannello (cod. PGD0000F00)

- Questi terminali sono stati progettati per il montaggio a pannello; la ditta di fornitura deve avere dimensioni di 127x69 mm + 2 fori circolari diametro 4 come indicato in Fig. 8. Per l'installazione seguire le istruzioni riportate di seguito:
- Effettuare il collegamento del cavo telefonico;
 - Inserire il terminale, privo di cornice frontale, nel foro, e mediante le viti a testa svasata, contenute all'interno dell'imballo, fissare il dispositivo al pannello nelle sedi indicate in Fig. 1;
 - Infine, installare la cornice a scatto.

Montaggio a parete (cod. PGD0000W00)

- Il montaggio a parete del terminale prevede l'iniziale fissaggio del retrocontenitore A (Fig. 2), per mezzo di una scatola standard a 3 moduli per interruttori.
- Fissare il retrocontenitore alla scatola tramite le viti a testa bombata presenti all'interno dell'imballo;
 - Effettuare il collegamento del cavo telefonico;
 - Appoggiare il frontale al retrocontenitore e fissare il tutto utilizzando le viti a testa svasata presenti all'interno dell'imballo come illustrato in Fig. 2;
 - Infine, installare la cornice a scatto.

Collegamento elettrico

Collegare il cavo telefonico (cod. S80CONN007) proveniente dalla scheda pCO all'apposito connettore (RJ12) posto sul retro del terminale.

Configurazione indirizzo

- È possibile configurare l'indirizzo del terminale solo dopo aver fornito alimentazione allo stesso tramite il connettore telefonico RJ12 (il valore preimpostato in fabbrica è 32).
- Per entrare in modalità configurazione premere contemporaneamente i tasti \downarrow , \uparrow , \leftarrow , \rightarrow (sempre presenti in tutte le versioni) per almeno 5 secondi; verrà visualizzata la maschera di Fig. 3 con il cursore lampeggiante nell'angolo in alto a sinistra.
- Per modificare l'indirizzo del terminale (display address setting) premere una volta il tasto \leftarrow . Il cursore si sposterà sul campo indirizzo (nn).
 - Tramite i tasti \uparrow , \downarrow selezionare il valore voluto, e confermare ripremendo il tasto \rightarrow . Se il valore selezionato è diverso da quello memorizzato precedentemente apparirà la maschera di Fig. 4 e il nuovo valore verrà memorizzato nella memoria permanente del display.
 - Se si imposta il campo nn al valore 0, il terminale comunicherà con la scheda pCO usando il protocollo "punto-punto" (non pLAN) e il campo "IO Board address: xx" scompare in quanto primo di significato.

pCO: assegnazione lista terminali privati e condivisi

- A questo punto, se fosse necessario modificare la lista dei terminali associata ad ogni singola scheda pCO, si dovrà seguire la seguente procedura:
- entrare nella modalità configurazione con i tasti \downarrow , \uparrow , \leftarrow , \rightarrow come descritto nel paragrafo precedente;
 - premere il tasto \leftarrow fino a che il cursore si posizioni sul campo xx (IO board address) Fig. 3;
 - tramite i tasti \uparrow , \downarrow scegliere l'indirizzo della scheda pCO desiderata. I valori selezionabili saranno solo quelli delle schede pCO effettivamente in linea. Se la rete pLAN non funziona, correttamente, oppure non è presente nessuna scheda pCO, non sarà possibile modificare il campo che mostrerà solo \rightarrow ;
 - premendo ancora una volta il tasto \leftarrow verranno visualizzate in sequenza le maschere di Fig. 5;
 - anche qui il tasto \leftarrow muove il cursore da un campo all'altro e i tasti \uparrow , \downarrow cambiano il valore del campo corrente. Il campo P-xx mostra l'indirizzo della scheda selezionata, nell'esempio di figura è stata selezionata la 12;
 - per uscire dalla procedura di configurazione e memorizzare i dati, selezionare il campo "OK" e impostare "Yes e confermare con il tasto \rightarrow ;
 - I campi della colonna "Addr" rappresentano gli indirizzi dei terminali associati alla scheda pCO di indirizzo 12, mentre la colonna "Priv/Shared" indica il tipo di terminale.
 - Attenzione: i terminali della linea pGD non possono essere configurati come "Sp" (shared printer) in quanto privi dell'uscita stampante.
 - Se il terminale rimane inattivo (nessun tasto premuto) per più di 30 secondi esce automaticamente dalla procedura di configurazione senza memorizzare gli eventuali cambiamenti.

Segnalazione guasti

Se il terminale (nella lo stato di fuori linea della scheda pCO a cui è stato associato) cancella il display e visualizza il messaggio: **I/O Board xx fault**.
Mente, se il terminale non riceve nessun segnale di rete, cancella il display e visualizza il seguente messaggio: **NO LINK**.

Thank you for your choice. We trust you will be satisfied with your purchase.

The pGD graphic display is an electronic device that is compatible with the previous pCO(IPCOT line terminals; it allows complete management of graphics by the display of icons (defined at an application software development level), as well as the management of international fonts, in two sizes: 5x7 and 11x15 pixels. The application software resides on the pCO board, and therefore the terminal does not require any additional software for operation. Furthermore, the terminals feature a wide operating temperature range (-20/60 °C) and in the built-in version, the front panel ensures a high index of protection (IP65).

Model codes

Built-in or panel-mounted version PGD0000F00
Wall-mounted version PGD0000W00

Panel-mounted version (code PGD0000F00)

- These terminals have been designed for panel installation; the drilling template measures 127x69 mm and has 2 circular holes, 4 mm in diameter, as shown in Fig. 8. For installation, proceed as follows:
- Connect the telephone cable;
 - Insert the terminal, with the front frame removed, into the opening, and fasten the device to the panel using the flush-head screws, supplied in the packaging, as shown in Fig. 1;
 - Finally, fit the click-on frame.

Wall-mounted version (code PGD0000W00)

- The wall-mounting of the terminal first requires the back piece of the container A (Fig. 2) to be fitted, using a standard three-module switch box.
- Fasten the back piece to the box using the rounded-head screws supplied in the packaging;
 - Connect the telephone cable;
 - Rest the front panel on the back piece and fasten the parts together, using the flush-head screws supplied in the packaging, as shown in Fig. 2;
 - Finally, fit the click-on frame.

Electrical connection

Connect the telephone cable (code S80CONN007) from the pCO board to the connector provided (RJ12) on the rear of the terminal.

Configuring the address

- The address of the terminal can be configured only after having connected the power supply, using the RJ12 telephone jack (the factory default value is 32).
- To access configuration mode, press the \downarrow , \uparrow , \leftarrow , \rightarrow buttons (present on all versions) together and hold them for at least 5 seconds; the screen shown in Fig. 3 will be displayed, with the cursor flashing in the top left corner.
- To change the address of the terminal (display address setting), press the \leftarrow button once; the cursor will move to the address field (nn).
 - Use the \uparrow , \downarrow buttons to select the desired value, and confirm by pressing \rightarrow again. If the value selected is not the same as the one saved previously, the screen shown in Fig. 4 will be displayed, and the new value will be saved to the permanent memory.
 - If the field nn is set to 0, the terminal will communicate with the pCO board using "point-to-point" protocol (not pLAN) and the field "IO Board address: xx" will not be displayed, as it has no meaning.

pCO: assigning the list of private and shared terminals

- At this point, if the list of terminals associated with each individual pCO board needs to be modified, proceed as follows:
- access configuration mode using the \downarrow , \uparrow , \leftarrow , \rightarrow buttons, as described in the previous paragraph;
 - press the \leftarrow button until the cursor moves to the field xx (IO board address) Fig. 3;
 - use the \uparrow , \downarrow buttons to select the pCO board in question. The values available correspond to the pCO boards that are effectively on line. If the pLAN network is not working correctly, or if no pCO board is present, the field cannot be modified, and the symbol \rightarrow will be displayed;
 - pressing \leftarrow again displays the screens shown in Fig. 5, in sequence;
 - here too, the \leftarrow button moves the cursor from one field to the next, and the \uparrow , \downarrow buttons change the value of the current field. The field P-xx shows the address of the board selected; in the example shown in the figure, the value 12 has been selected;
 - to exit the configuration procedure and save the data, select the field "OK", choose "Yes" and confirm by pressing \rightarrow .
 - The fields in the "Addr" column represent the addresses of the terminals associated with the pCO board that has address 12, while the Priv/Shared column indicates the type of terminal.
 - Note: the pGD terminals cannot be configured as "Sp" (shared printer), as they have no printer port.
 - If the terminal remains inactive (no button is pressed) for more than 30 seconds, the configuration procedure is exited automatically, without saving any changes.

Fault signals

If the terminal detects the off-line status of the pCO board it is associated with, the display shows the message: **I/O Board xx fault**.
On the other hand, if the terminal receives no signal from the network, the display shows the following message: **NO LINK**.



Terminale versione da incasso
Panel mounting terminal

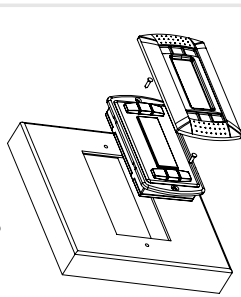

Fig. 1

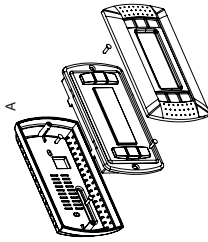

Fig. 2

Configurazione indirizzo / Configuring the address

```
Display address
setting.....inn
I/O Board address:xx
```

Fig. 3

Assegnazione lista terminali privati e condivisi / Assigning the list of private and shared terminals

```
Terminal Config
Press ENTER
to continue
```

```
P12: P01c Priv/Shared
Trm1 00 Sh
Trm2 03 Ph
Trm3 None --OK?N0
```

Fig. 5

Assegnazione lista terminali privati e condivisi Assigning the list of private and shared terminals



Fig. 6



Fig. 7

Dimensioni / Dimensions

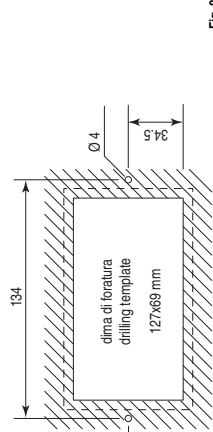

Fig. 8

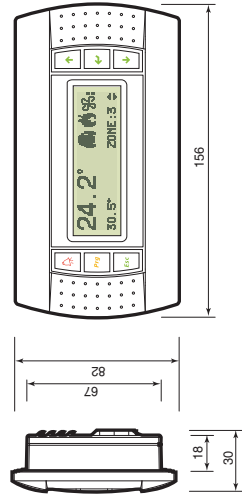

Fig. 9

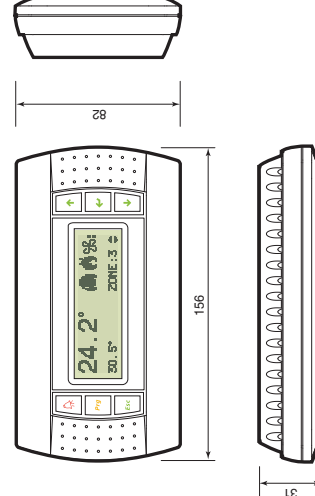

Fig. 10

Visualizzazione stato rete e versione del firmware

Premento contemporaneamente i tasti di configurazione (↑ ↓ ← →) per almeno 10 secondi (solo in modalità pLAN), si visualizza la maschera di Fig. 6.

La schermata in Fig. 6 esemplifica lo stato della rete pLAN, visualizzando quanti e quali dispositivi sono collegati, e con quale indirizzo.

Legenda:

- ☐ : controllore pCO attivo in rete
 - ☒ : terminale attivo in rete
 - ☐ : nessun dispositivo collegato
- Es. la Fig. 4 rappresenta:
 controlleri pCO attivi in rete con indirizzo: 1, 2, 25
 terminali attivi in rete con indirizzo: 3, 4, 15, 26.

Tramite i tasti ↑ ↓ è possibile visualizzare la versione del firmware residente nel terminale (Fig. 7).

Per uscire dalla procedura NetSTAT, premere il tasto ↓.

Regolazione contrasto LCD

I tasti ← + Prg + ↑ ↓ consentono la regolazione del contrasto.

Caratteristiche tecniche

Display	grafico FSTN
Retroilluminazione:	LED verdi (comandabile da "software applicativo")
Risoluzione in grafica:	120x32 pixel
Modi testo:	4 righe x 20 colonne (font 5x7 e 11x15 pixel) 2 righe x 10 colonne (font 11x15 pixel) oppure modi misti
Altezza carattere:	4,5 mm (font size 5x7 pixel) 9 mm (font 11x15 pixel)
Dimensione area attiva:	71,95x20,75 mm
Dimensione area visiva:	76x25,2 mm
LED tastiera	2 programmabili da "software applicativo" di colore rosso e aereo (tasti Prg e Alarm) 4 di colore verde, asserviti al comando backlight dell'LCD (tasti ↑ ↓ ← → e Esc)
Alimentazione	alimentazione da pCO tramite cassetto e telefonico oppure da sorgente esterna: 18/30 Vdc protetto da fusibile esterno da 250 mA/T
Tensione:	0,8 V
Potenza assorbita massima:	
Distanze maxime	500 m con cavo AWG22 a coppie schermate
Lunghezza massima rete pLAN:	500 m con cavo AWG22 a coppie schermate e TCONWG.000
Distanza pCO terminale:	Nota: per raggiungere la lunghezza massima utilizzare una tipologia a bus con dimensioni che non superano i 5 m.
Materiali	
Frontale trasparente:	poli carbonato trasparente
Retrocontattori grigio antracite (parete/incasso):	poli carbonato +ABS
Tastiera:	gomma, silicombica
Vetino trasparente/cornice:	poli carbonato trasparente
Autocollinguenza:	Vo su fronte trasparente e retrocontattori HB su lastre silicombica e particolari resistenti
Generali	
Grado di protezione:	IP65 con montaggio a pannello IP40 con montaggio a parete UL type 1
Condizioni di funzionamento:	-20/60 °C, 90% U.R. non condensante
Condizioni di immagazzinamento:	-20/70 °C, 90% U.R. non condensante
Classe e struttura del software:	A
Classificazione secondo il grado di protezione contro le scosse elettriche:	Da incorporare in apparecchiature di classe I o II
PTI dei materiali di isolamento:	250 V
Periodo delle sollecitazioni elettriche:	lungo
Categoria di resistenza al calore e al fuoco:	D
Categoria (immunità) contro le sovradensioni:	I
Inquinamento ambientale:	normale

Displaying the status of the network and firmware version

Pressing the configuration buttons (↑ ↓ ← →) together for at least 10 seconds (in pLAN mode only), displays the screen shown in Fig. 6.

The screen shown in Fig. 6 provides an example of the status of the pLAN, displaying which and how many devices are connected, and the corresponding addresses.

Key:

- ☐ : pCO controllers active in network
 - ☒ : terminals active in network
 - ☐ : no device connected
- The example in Fig. 4 represents:
 pCO controllers active in network, addresses: 1, 2, 25
 terminals active in network, addresses: 3, 4, 15, 26.

The ↑ ↓ buttons can be used to display the version of the firmware resident in the terminal (Fig. 7).

To exit the NetSTAT procedure, press ↓.

Contrast adjustment

Use ← + Prg + ↑ ↓ buttons to adjust the contrast.

Technical specifications

Display	FSTN, graphic
Type:	green LEDs (controlled by "application software")
Backlighting:	120x32 pixels
Graphic resolution:	4 rows x 20 columns (font sizes 5x7 and 11x15 pixels) 2 rows x 10 columns (font size 11x15 pixels) or mixed modes
Text mode:	
Character height:	4.5 mm (font size 5x7 pixels) 9 mm (font size 11x15 pixels)
Size of active area:	71.95x20.75 mm
Size of display area:	76x25.2 mm
Keypad LEDs	2 programmable by "application software", red and orange (Prg and Alarm buttons) 4 green LEDs, used as backlighting for LCD (↑ ↓ ← → and Esc buttons)
Power supply	power supply from pCO through telephone cable or external source: 18/30 Vdc, protected with 2.250 mA/T fuse
Voltage:	0.8 V
Maximum power input:	
Maximum distances	500 m with AWG22 twisted pair cable
Maximum pLAN length:	500 m with AWG22 twisted pair cable and TCONWG.000
pCO terminal distance:	Notes: to reach the maximum length, use a bus layout, with branches not exceeding 5 m.
Materials	
Transparent front panel:	transparent polycarbonate
Charcoal grey container back piece (wall/built-in):	polycarbonate +ABS
Keypad:	silicon rubber
Transparent cover glass/frame:	transparent polycarbonate
Self-extinguishing classification:	V0 for transparent front panel and back piece HB for silicon keypad and remaining parts
Others	
Index of protection:	IP65 for panel mounting IP40 for wall mounting UL type 1
Operating conditions:	-20/60 °C, 90% r.H. non-condensing
Storage conditions:	-20/70 °C, 90% r.H. non-condensing
Software class and structure:	A
Classification according to protection against electric shock:	To be integrated into class 1 or 2 devices
PTI of insulating materials:	250 V
Period of electric stress across insulating parts:	long
Category of resistance to fire and heat:	D
Category (immunity) against voltage surges:	I
Environmental pollution:	normal

SANYO SCROLL COMPRESSORS

*For Air Conditioning
For Refrigeration*



C-SB Series



C-SC Series



C-SD Series

Dalian SANYO Compressor Co., Ltd.



R407C

R407C - B8 (50Hz 380-415V / 60Hz 440-460V)

Phase	Out Put HP	Displacement cm ³ /rev	Compressor Model	Compressor Code	Starting Method	50Hz				60Hz				Outline Graph Code
						Nominal Capacity		COP		Nominal Capacity		COP		
						kW	kBTU/h	W/W	BTU/Wh	kW	kBTU/h	W/W	BTU/Wh	
3	3.5	55.7	C-SBN263H8A	809 930 88	—	9.60	32.8	2.87	9.8	11.8	40.3	2.87	9.8	B
			C-SBN303H8A	809 940 88	—	11.6	39.6	3.05	10.4	14.6	49.8	3.17	10.8	A
	4	66.8	C-SBN303H8G	809 946 88	—	11.6	39.6	3.05	10.4	14.6	49.8	3.17	10.8	At
			C-SBN353H8A	809 942 88	—	13.4	45.8	2.91	9.9	16.5	56.3	2.95	10.1	A
	4.5	77.4	C-SBN353H8G	809 944 88	—	13.4	45.8	2.91	9.9	16.5	56.3	2.95	10.1	At
			C-SBN373H8A	809 950 88	—	14.5	49.5	2.93	10.0	17.8	60.8	2.99	10.2	A
	5	83.2	C-SBN373H8G	809 956 88	—	14.5	49.5	2.93	10.0	17.8	60.8	2.99	10.2	At
			C-SBN453H8A	809 960 88	—	17.6	60.1	3.03	10.3	21.3	72.7	3.04	10.4	A
	6	100.0	C-SBN453H8G	809 966 88	—	17.6	60.1	3.03	10.3	21.3	72.7	3.04	10.4	At
			C-SBS235H38A	—	—	19.5	66.6	3.10	10.6	23.4	79.9	3.10	10.6	A
	7	110.2	C-SBS235H38B	—	—	19.5	66.6	3.10	10.6	23.4	79.9	3.10	10.6	At
			C-SCN583H8H	809 184 88	—	23.6	80.6	3.13	10.7	28.0	95.6	3.03	10.3	D
	8	131.9	C-SCN603H8H	809 181 88	—	24.5	83.6	3.16	10.8	29.1	99.4	3.08	10.5	D
		137.0	C-SCN603H8K	809 183 88	—	24.5	83.6	3.16	10.8	29.1	99.4	3.08	10.5	Dt
	10	171.2	C-SCN753H8H	809 101 88	—	29.9	102.1	3.20	10.9	35.9	122.6	3.12	10.7	E
		171.2	C-SCN753H8K	809 103 88	—	29.9	102.1	3.20	10.9	35.9	122.6	3.12	10.7	Et
12	205.4	C-SCN903H8H	809 121 88	—	34.9	119.2	3.09	10.5	—	—	—	—	E	
	205.4	C-SCN903H8K	809 123 88	—	34.9	119.2	3.09	10.5	—	—	—	—	Et	

R407C - B8 (50Hz 380-415V / 60Hz 440-460V)

T3 Models

Phase	Out Put HP	Displacement cm ³ /rev	Compressor Model	Compressor Code	Starting Method	50Hz				60Hz				Outline Graph Code
						Nominal Capacity		COP		Nominal Capacity		COP		
						kW	kBTU/h	W/W	BTU/Wh	kW	kBTU/h	W/W	BTU/Wh	
3	4.5	77.4	C-SBS165H38P	—	—	13.4	45.8	2.91	9.9	16.5	56.3	2.95	10.1	A
	6	83.2	C-SBS215H38P	—	—	17.6	60.1	3.03	10.3	21.3	72.7	3.04	10.4	A

R407C - B8 (50Hz 380-415V / 60Hz 440-460V)

EVI Models

Phase	Out Put HP	Displacement cm ³ /rev	Compressor Model	Compressor Code	Starting Method	50Hz cooling				50Hz heating				Outline Graph Code
						Nominal Capacity		COP		Nominal Capacity		COP		
						kW	kBTU/h	W/W	BTU/Wh	kW	kBTU/h	W/W	BTU/Wh	
3	3.5	55.7	C-SBS120H38Q	—	—	10.1	34.5	3.00	10.2	10.5	35.8	3.18	10.9	Developing
	4	66.8	C-SBS145H38Q	—	—	12.1	41.3	3.10	10.6	12.2	41.7	3.20	10.9	Developing
	5	83.2	C-SBS180H38Q	—	—	15.3	52.2	3.14	10.7	15.0	51.2	3.20	10.9	Developing
	8	137.0	C-SCS295H38Q	—	—	24.5	83.6	3.16	10.8	24.6	84.0	3.22	11.0	Developing
10	171.2	C-SCS370H38Q	—	—	29.9	102.1	3.20	10.9	30.7	104.8	3.25	11.1	Developing	

R407C - B5 (50Hz 220-240V)

Phase	Out Put HP	Displacement cm ³ /rev	Compressor Model	Compressor Code	Starting Method	50Hz				Outline Graph Code
						Nominal Capacity		COP		
						kW	kBTU/h	W/W	BTU/Wh	
1	3.5	55.7	C-SBN261H5A	809 930 45	CSR	9.70	33.1	2.85	9.7	A
			C-SBS120H15A	—	PSC	9.70	33.1	2.85	9.7	A
	4	66.8	C-SBN301H5A	809 940 45	CSR	11.8	40.3	2.95	10.1	A
			C-SBS145H15A	—	PSC	11.8	40.3	2.95	10.1	A
	4.5	77.4	C-SBN351H5A	809 942 45	PSC	13.5	46.1	2.84	9.7	A
			C-SBS165H15A	—	PSC	13.5	46.1	2.84	9.7	A
5	83.2	C-SBN371H5A	809 950 45	PSC	14.5	49.5	2.91	9.9	A	
		C-SBS180H15A	—	PSC	14.5	49.5	2.91	9.9	Developing	
3	3.5	55.7	C-SBN263H5A	809 930 85	—	9.85	33.6	2.94	10.0	A
	4	66.8	C-SBN303H5A	809 940 85	—	11.5	39.3	2.99	10.2	A
	5	83.2	C-SBN373H5A	809 950 85	—	14.7	50.2	2.91	9.9	A
	6	100.0	C-SBN453H5A	809 960 85	—	17.7	60.4	3.00	10.2	A
	8	131.9	C-SCN583H5H	809 184 85	—	23.7	80.9	3.14	10.7	D
		137.0	C-SCN603H5H	809 181 85	—	24.2	82.6	3.14	10.7	D
	10	171.2	C-SCN753H5H	809 101 85	—	29.9	102.1	3.18	10.9	E
12	205.4	C-SCN903H5H	809 121 85	—	34.8	118.8	3.08	10.5	E	

R407C - B9 (60Hz 380V)

Phase	Out Put HP	Displacement cm ³ /rev	Compressor Model	Compressor Code	Starting Method	60Hz				Outline Graph Code
						Nominal Capacity		COP		
						kW	kBTU/h	W/W	BTU/Wh	
3	5	83.2	C-SBN373H9A	809 950 89	—	18.0	61.5	3.05	10.4	A

■ Rating Condition

	R22 / R407C / R410A	
	°C	°F
Condensing Temperature	54.4	130
Evaporating Temperature	7.2	45
Sub Cooling	8.3	15
Super Heating	11.1	20

■ Rating Condition for EVI

	Cooling		Heating	
	°C	°F	°C	°F
Condensing Temperature	54.4	130	50	122
Evaporating Temperature	7.2	45	-7	19.4
Sub Cooling	8.3	15	2	3.6
Super Heating	11.1	20	11.1	20

■ Rating Condition for Refrigeration (R22 / R404A)

	fixed speed		Inverter	
	°C	°F	°C	°F
Condensing Temperature	50	122	50	122
Evaporating Temperature	-15	5	-10	14
Sub Cooling	0	0	0	0
Suction Gas Temperature	18.3	65	18.3	65

■ Power Source

Code	Phase	50Hz	60Hz
B3	3 Phase	200V	200-220V
B5	1 Phase	220-240V	-
	3 Phase	220-240V	-
B6	1 Phase	-	208-230V
	3 Phase	-	208-230V
B8	3 Phase	380-415V	440(-460)V
B9	3 Phase		380V

■ Subscripts of Outline Graph Code

Subscript	explanation
t	The connection port of oil balance tube is attached
s	Screw type power supply connection

Operating Envelope

Suction Gas Superheat :9K

Refrigerant : R407C

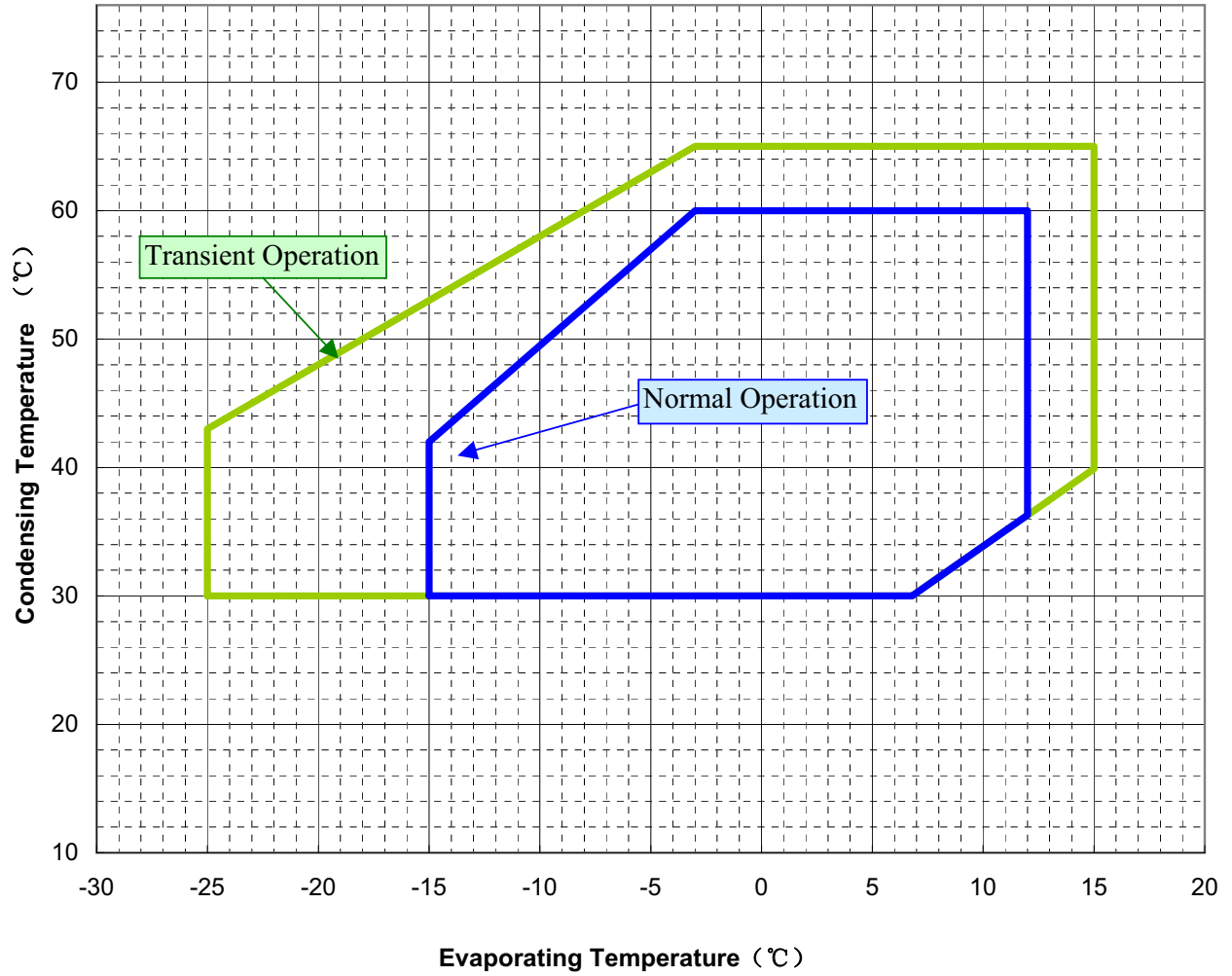

APPLICATION STANDARD & LIMIT (R407C)

The following requirements apply to Vertical type Hermetic Scroll Compressors:

Standard: Applicable to ordinary conditions in Japan JIS B8616 or equivalent conditions, such as standard rating conditions, maximum operating conditions, low temperature conditions, etc.

Limit: Applicable to transitional brief periods, such as start-up and beginning of defrost mode.

No.	Item	Standard	Limit	Note
1	Refrigerant	R407C		
2	Evaporating Temp.	-15~+12°C/[5~54 ° F] 0.20~0.65MPa(G)/[29~94psig]	-25~+15°C/[-13~59 ° F] 0.07~0.73MPa(G)/[10~106psig]	Average temp. of evaporator Inlet and outlet.
3	Condensing Temp.	+30~+60°C/[86~140 ° F] 1.17~2.56MPa(G)/[170~371psig]	+65°C/[149 ° F] 2.88MPa(G)/[418psig]	Average temp. of condenser Inlet and outlet.
4	Compression Ratio	2 ~ 6	10	
5	Winding Temp.	115°C/[240 °F] Max.	125°C/[257 °F]	
6	Shell Bottom Temp.	Upper Limit: 90 °C/[194 °F] Max.		
		Lower Limit: Evaporating Temp. +12K / [21 °F] Min. Ambient Temp. +11K / [20 °F] Min.		When comp. Is running When comp. shuts off
7	Discharge Gas Temp.	115°C/[240 °F] Max.	C-SB:130°C/[266°F] Max.	Within 100mm(4in) of the discharge fitting.
			C-SC:135°C/[275°F] Max.	Inside of the well pipe on the top of comp.
8	Suction Gas Temp.	Superheat: 5K/[10 °F] Min.	No excessive noise	It should meet the requirement of item 5, 6, 7 and 14 within 300mm of the suction fitting.
9	Running Voltage	Within ±10% of the rated voltage		Voltage at comp. terminals.
10	Starting Voltage	Three Phase Models: 85% of the rated voltage min.		Dropped voltage at comp. terminals.
		Single Phase Models: 90% of the rated voltage min.		
11	On/Off Period	ON Period: Until the oil level returns to the center of the lower bearing OFF Period: Until balance of high and low pressure is obtained		For at least 7 minutes -ON/3 minutes-OFF is recommendable.
12	Refrigerant Charge	Oil/Refrigerant(wt.)>0.35		Specific gravity of the Oil: 0.94.
13	Life Time	200,000 cycle		
14	Minimum Oil Level	C-SB: Center of the lower bearing	C-SB:Bottom of the lower bearing	
		C-SC:No less than 70% of the initial oil charge		
15	Abnormal Pressure Rise/Drop	Pressure Rise: 3.20MPa(G) / [464psig] Max.		By high pressure switch
		Pressure Drop: 0.05MPa(G)/[7.3psig] Min.		By low pressure switch
16	System Moisture Level	200ppm Max.		
17	System Uncondensable Gas Level	1 Vol.% Max. Residual Oxygen 0.1 Vol.% Max.		24 hrs. after vacuuming: 1.01kPa Max.
18	Tilt	5° Deg.Max.		

Operation beyond the above limits must be approved by Dalian SANYO Compressor Co., Ltd.

(G): Gauge Pressure

Notes

- 1 Installation should be completed within 15 minutes after removing the rubber plugs.
- 2 Do not use the compressor to compress air.
- 3 Do not energize the compressor under vacuumed condition.
- 4 Evacuation and Refrigerant charge: Evacuate internal section in the refrigeration system from high and low pressure sides and charge liquid refrigerant from condenser outlet side. Additional charge shall be done with gas condition from low side.
- 5 Do not tilt over the compressor while carrying it.
- 6 Do not remove the paint.
- 7 Crankcase heater is required when the oil sump temperature is too low to meet the requirement of item 6 .
- 8 Voltage fluctuation between compressor terminals, during operation, shall be within 2% of the rated voltage.
- 9 Do not operate compressor in reverse rotational direction.
- 10 Suction strainers are recommended for all applications.
- 11 Copper Piping Stress

Start/Shutdown	34.32 N/mm ² Max.
Run	12.26 N/mm ² Max.

INSTALLATION INSTRUCTIONS

Liquid Level Switch - Model L-21N, L-21CR and L-21VCR

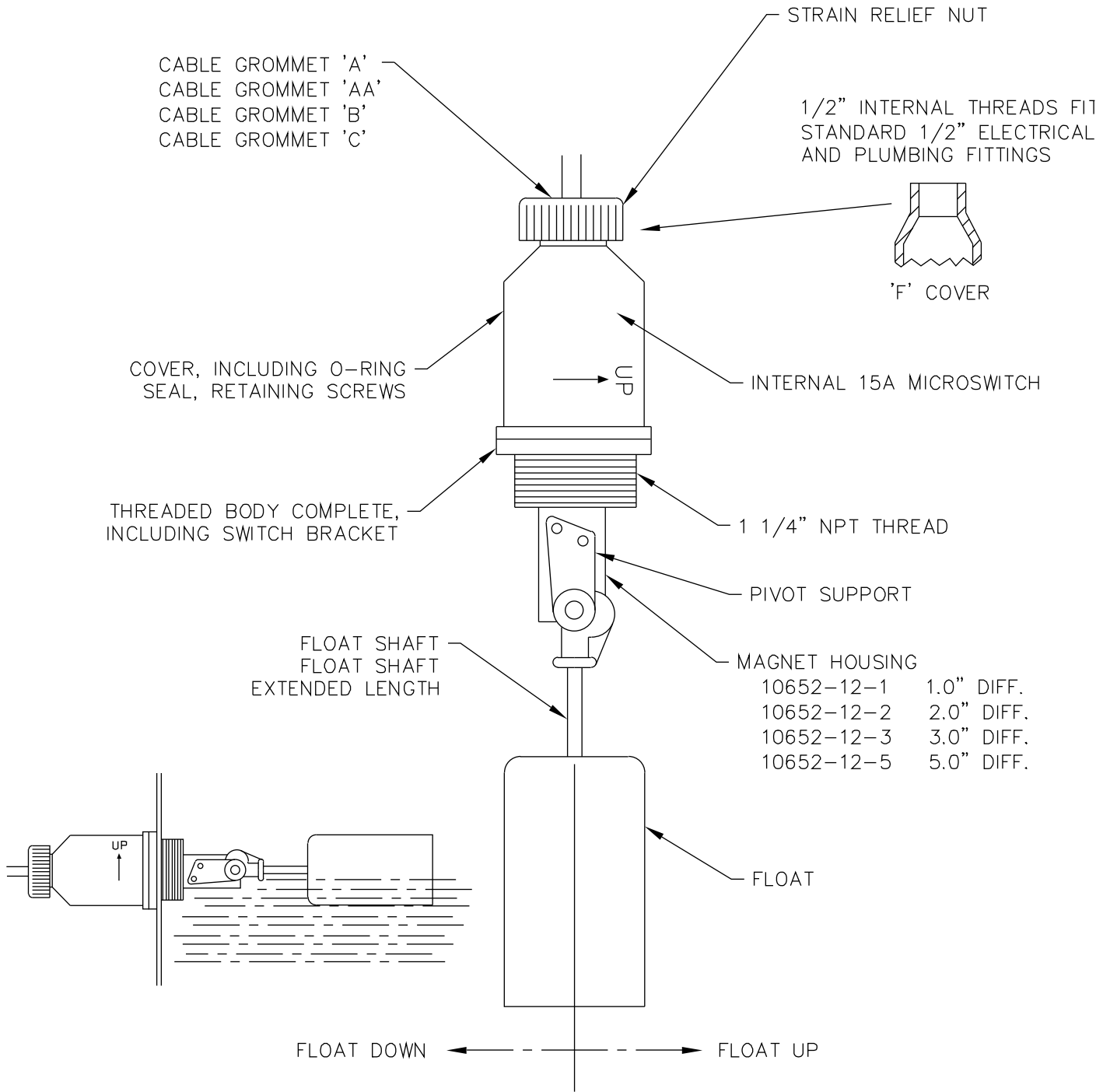

CORPORATION

221 Lombard Street, Oxnard, CA, 93030
 Phone: (805) 988-6800 FAX: (805) 988-6804
 E-Mail: harwil@ix.netcom.com
 Internet: www.harwil.com

INSTALLATION INSTRUCTIONS

Liquid Level Switch - Model L-21N, L-21CR and L-21VCR

INSTALLATION & OPERATING INSTRUCTIONS

- 1) If shipping container and contents are received damaged, place complete package in separate container and immediately call shipping company for damage inspection and file appropriate report with copy to HARWIL Corp. for product replacement and insurance adjustment.
- 2) If contents are not damaged, inspect units received against packing list and original purchase order. If incorrect units are received, call HARWIL Corp. immediately for resolution of problem Tel: (805) 988-6800, Fax: (805) 988-6804.
- 3) Check for damage or scuffing or teflon tape applied to 1-1/4" NPT threads of switch body. Retape as required with 2 to 3 layers wound clockwise looking at end of threaded body with float toward viewer.
- 4) Remove switch and check switch action with a multimeter while moving float up and down.

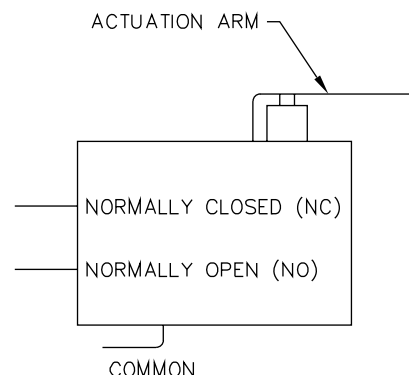

FLOAT UP/DOWN CONFIGURATION

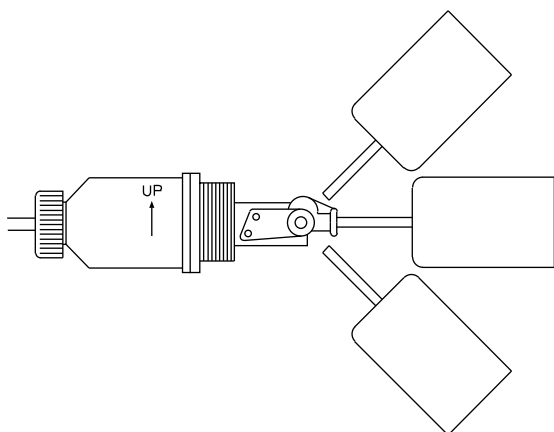

FLOAT POSITION	MULTIMETER CONNECTION	METER READING
UP	COMM. & NO TERMINALS	CONTINUITY
	COMM. & NC TERMINALS	OPEN CIRCUIT
DOWN	COMM. & NO TERMINALS	OPEN CIRCUIT
	COMM. & NC TERMINALS	CONTINUITY

5) Replace domed cover on unit and insert float through 1-1/4" NPT hole in tank and mate switchbody threads with tank threads and tighten with appropriate wrench until thread joint is leak tight and arrow on cover label is pointing vertically upward.

*NOTE: Model L-21 can be supplied with 1-1/2" x 1-1/4" reducer bushings or larger bushings as required to fit existing large hole in tank wall.

6) Remove cover and wire as indicated below.



HARWIL CORPORATION

221 Lombard Street, Oxnard, CA, 93030
 Phone: (805) 988-6800 FAX: (805) 988-6804
 E-Mail: harwil@ix.netcom.com
 Internet: www.harwil.com

INSTALLATION INSTRUCTIONS

Liquid Level Switch - Model L-21N, L-21CR and L-21VCR

LOW LIQUID LEVEL ALARM

Fig. 1: Wiring schematic for power applied to load when liquid level is less than set point (power to load interrupted when level increases to above set point).

Decreasing Liquid Level moves actuator in direction shown.

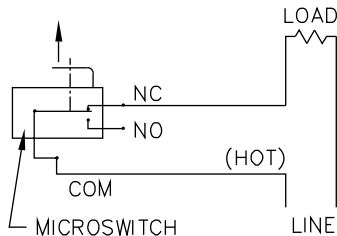

HIGH LIQUID LEVEL ALARM

Fig 2: Wiring schematic for power applied to load when liquid level is greater than set point (power to load interrupted when level decreases to below set point).

Increasing Liquid Level moves actuator in direction shown.

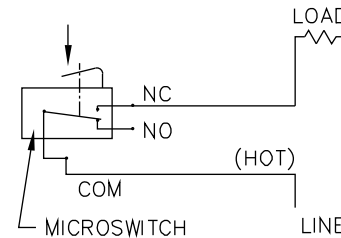

Micro switch actuation point may be monitored by an audible click or with an OHM meter before connecting line power to the switch terminals or by monitoring the voltage supplied to the load through the micro switch.

- Pump Up wiring diagram same as low level alarm shown in Fig. 1 above.
- Pump Down wiring diagram same as high level alarm show In Fig. 2 above.

Electrical Wiring:

- Step 1: Remove gland nut, grommet and switch cover.
- Step 2: Strip outer jacket of electrical cord back approximately 1-1/4" inches. Strip insulation from individual conductors back approximately 1/4 inch.
- Step 3: Slip on terminals are supplied with each switch. Remove from switch terminals and crimp on or solder to electrical leads.
- Step 4: Feed electrical cable through gland nut, grommet and switch cover as shown.
- Step 5: Apply slip on terminals to appropriate contacts of microswitch. Slide cover down cable and fasten to body of switch with 4 screws provided. Slide grommet down cable and push grommet into tapered end of cover. Hold cable jacket to prevent rotation and thread gland nut firmly onto cover.

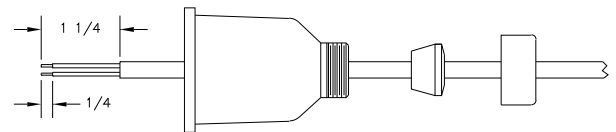

Electrical Wiring:

- Step 1: Remove switch cover.
- Step 2: Same as step 2 above.
- Step 3: Same as step 3 above.
- Step 4: Thread user supplied 1/2" flexible conduit fitting into 1/2" female thread on end of cover. Feed electrical cable through conduit fitting.
- Step 5: Apply slip on terminals to appropriate male spade contacts on microswitch. Slide cover down cable and fasten to body of switch with 4 screws provided. Be sure to install "O" ring between body and cover. Connect flexible 1/2" metal or plastic conduit to conduit fitting on end of cover per



221 Lombard Street, Oxnard, CA, 93030
Phone: (805) 988-6800 FAX: (805) 988-6804
E-Mail: harwil@ix.netcom.com
Internet: www.harwil.com

INSTALLATION INSTRUCTIONS

Liquid Level Switch - Model L-21N, L-21CR and L-21VCR

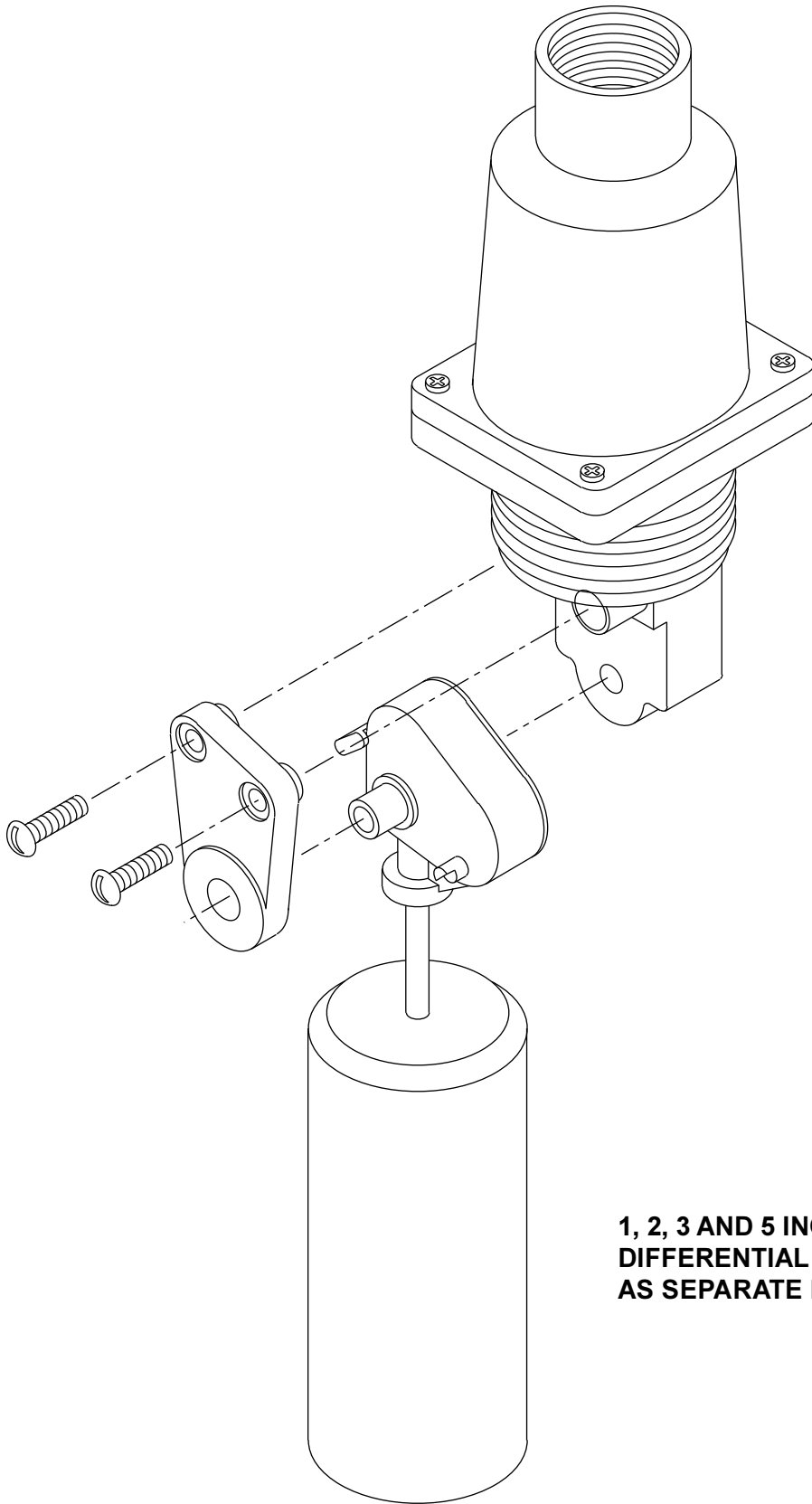

**1, 2, 3 AND 5 INCH LINE REPLACEABLE
DIFFERENTIAL FLOAT UNITS AVAILABLE
AS SEPARATE ITEMS**



CORPORATION

221 Lombard Street, Oxnard, CA, 93030
Phone: (805) 988-6800 FAX: (805) 988-6804
E-Mail: harwil@ix.netcom.com
Internet: www.harwil.com

INSTALLATION INSTRUCTIONS

Liquid Level Switch - Model L-21N, L-21CR and L-21VCR

L-21N (Series 21300)

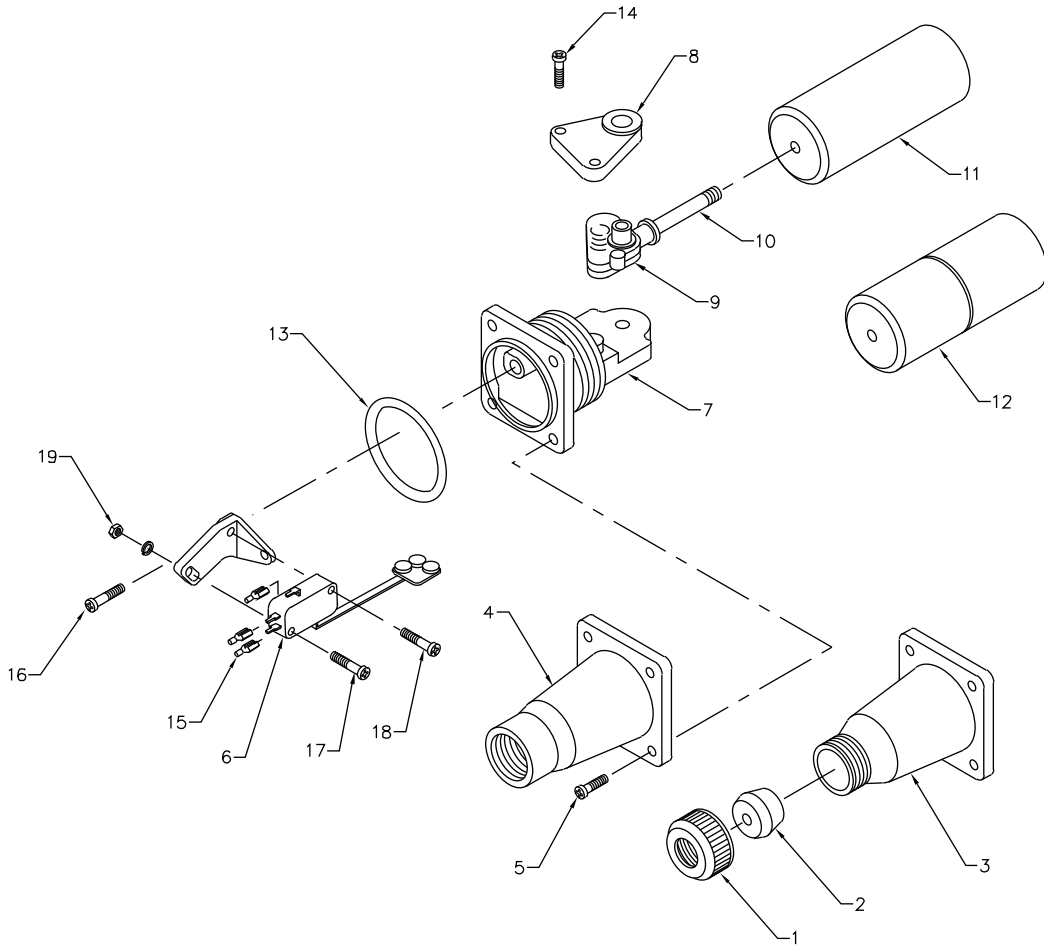

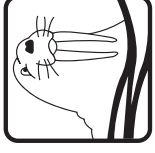

WALRUS

TPHK Series

Immersible Pump

Instruction Manual

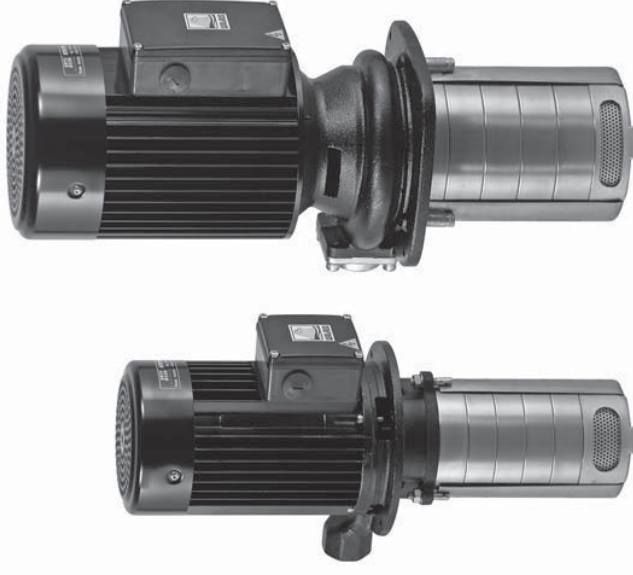

Limited Warranty

Products manufactured by Walrus Pumps Co (Walrus) are warranted to the first user only to be free of defects in material and workmanship for a period of 12 months from date of installation, but no more than 24 months from date of shipment. Walrus' liability under this warranty shall be limited to repairing or replacing at our election, without charge, FOB Walrus' distribution center or authorized service agent. Walrus will not be liable for any cost of removal, installation, transportation or any other charges that may arise in connection with warranty claim.

The warranty period commences on the date of original purchase of the equipment. Proof of purchase and installation date, failure date, and supporting installation data must be provided when claiming repairs under warranty.

This warranty is subject to due compliance by the original purchaser with all directions and conditions set out in the installation and operating instructions. Failure to comply with these instructions, damage or breakdown caused by fair wear and tear, negligence, misuse, incorrect installation, inappropriate chemicals or additives in the water, inadequate protection against freezing, rain or other adverse weather conditions, corrosive or abrasive water, lightning or high voltage spikes or through unauthorized persons attempting repairs are not covered under warranty.

Walrus will not be liable for any incidental or consequential damages, losses, or expenses, arising from installation, use, or any other causes. There are no express or implied warranties, including merchantability or fitness for a particular purpose, which extend beyond those warranties described or referred to above.

Certain states do not permit the exclusion or limitation of incidental or consequential damages or the placing of limitations on the duration of an implied warranty, therefore, the limitations or exclusions herein may not apply. This warranty sets forth specific legal rights and obligations, however, additional rights may exist, which may vary from state to state.

Supersedes all previous publications



WALRUS

Walrus Pump Co., Ltd.

Web: www.walruspump.com E-mail: walrus.pump@msa.hinet.net

C099C008E007-00

ISO 9001 Certified

Walrus Pump Co., Ltd.

EC Declaration of Conformity

We **WALRUS PUMP CO., LTD.** declare under our sole responsibility that the products : *Immersible Pump - TPHK series, to which this declaration relates, are in conformity with the Council Directives relating to*

- 98/37/EEC (Machinery Directive)

Standard used : EN 292 : 1991

EN 1050 : 1996

Pr EN 809 : 1992

- 89/336/EEC (Electromagnetic compatibility Directive)

- 73/23/EEC (Low-Voltage Directive)

Standard used : EN60335-1

EN60335-2-51 : 1997

R&D department manager: Kao Tien

Manager: Kao Jen chuan

Address: 83 -14, DA PIAN TOU, HO CHUOH VILLAGE,

SAN CHI, TAIPEI HSIEN, TAIWAN.

TEL: 886-2-26361123~7

FAX: 886-2-86352660

Date: May 10, 2004

Please read this instruction manual carefully before installing your new system as failures caused by incorrect installation and operation are not cover by the warranty.



1. Application

1.1. The TPHK series is multi-stage centrifugal pump designed for industrial use, especially for machine tools.

1.2. The pump can not be used to transfer explosive liquids; such as gasoline, diesel oil or similar liquids. It is suitable to carry liquids such as water, coolant, low viscosity or other non-corrosive liquids.

2. Product Code Designation

The standard range of pumps includes complete impeller in chamber combinations. Upon request, a special length can be supplied by fitting empty intermediate chambers instead of standard chambers with impellers. The pump nameplate indicates the number of chambers and impellers fitted to the pump.

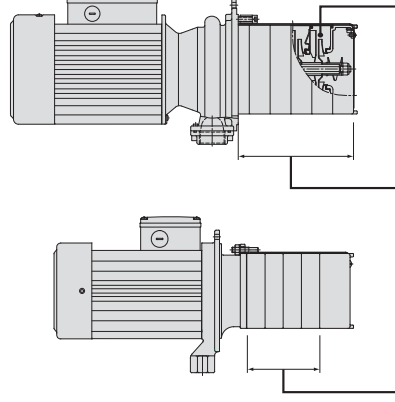

TPHK 2T ** - 4 S
Stainless steel series
Number of Impellers
Number of Stages
Standard capacity m³/hr
Model name

3. Operating Limits

1. Ambient temperature :Max. 50°C(122°F)
2. Liquid temperature range: 0°C(32°F) to 90°C(194°F)
3. Operating pressure :Max. 10 kg/cm²
4. Submerged depth :Min. 65mm

4. Installation

The pump has hot surface on the motor. It must be installed so that persons cannot accidentally come into contact the hot surface.



4.1. Submerged Depth

To avoid dry running and damage the pump during operation, the minimum pump submerged depth is 65mm (2 1/2") as shown in Fig 1. In addition, the bottom of the pump suction inlet must be at least 25 mm (1") above the bottom of the tank.

Fig.1

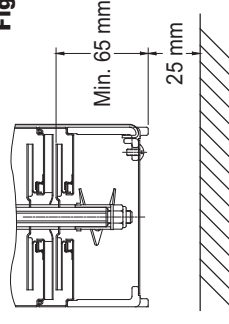

5. Electrical Connection

5.1 The electrical connection should be carried out in accordance with local regulations. Never make any connections unless the electricity supply has been switched off.



5.2. The electrical hazard warning mark is placed outside the connection box. Be careful.



5.3. Electrical data (voltage and frequency) are shown on the pump nameplate. Verify if these data match your electricity supply. A circuit breaker should be installed and the grounding be properly connected for your safety.

5.4. Make electrical connection in accordance with connecting diagram located inside the

connection box. The motor current must be within the rated amps range indicated on nameplate. Three phase motor requires a magnetic starter for safety.

5.5. For three phase motors, please check the correct direction of rotation of the pump on the motor fan cover. When seen from motor fan cover end, the pump should rotate clockwise. You can reverse the direction of rotation by interchanging any two of the incoming supply wires.

6. Start-up

Before starting the pump, make sure the following:

- 6.1. For three phase motors, verify if the rotating direction is correct. It should be clockwise viewing from the motor fan cover end.
- 6.2. All piping joints are completely tight. Leakage in piping may cause the pump hydraulic loss.
- 6.3. The pump is filled with liquid.
- 6.4. The suction filter is not blocked by any foreign objects.

7. Operation and Maintenance

It is dangerous to operate the pump against a closed discharge outlet because it will cause extremely high liquid flow temperature and damage the pump in a few minutes.



- 7.1. Lubrication
The mechanical seal and shaft sleeves are lubricated by the pumped liquid.
- 7.2. Suction filter
Always keep suction filter clean and make sure it is not blocked by impurities.
- 7.3. Periodic checks
The following checks should be carried out periodically to ensure the normal operation.
 - 7.3.1. Check the quantity of liquid and operating pressure.
 - 7.3.2. Check there are no leaks on piping joints.
 - 7.3.3. Check the tripping of the motor starter.
 - 7.3.4. Check that all controls are functioned normally.

- 7.4. The pump must not be used to transfer explosive liquids. In systems with hot liquids (over 60°C), extra caution should be exercised to prevent from personal injury.
- 7.5. The pump should not be used to transfer toxic or contaminated liquids. Please carefully follow all instructions in the manual as Walrus may refuse to accept the contaminated pump for servicing.

8. Sound pressure level

Motor	dB(A)	Motor	dB(A)
TPHK2T3-1	<70	TPHK4T3-1	<70
TPHK2T3-2	<70	TPHK4T3-2	<70
TPHK2T3-3	<70	TPHK4T3-3	<70
TPHK2T4-4	<70	TPHK4T4-4	<70
TPHK2T5-5	<70	TPHK4T5-5	<70
TPHK2T6-6	<70	TPHK4T6-6	<70
TPHK8T6-3	71	TPHK12T6-1	71
TPHK8T6-4	76	TPHK12T6-2	76
TPHK8T6-5	76	TPHK12T6-3	76

9. Fault Finding

Make sure electricity supply has been switched off before attempting to diagnose any fault

Fault	Cause
9.1. Motor does not start	a. No electricity supply
	b. Fuses are blown.
	c. Motor overheating relay tripped.
9.2. Motor cut out during operation.	d. Defective magnetic contactors.
	e. Control circuit malfunction.
	a. Fuses blown or breakers tripped.
9.3. Pumped capacity is not constant.	b. Overheating relay tripped.
	c. Control circuit malfunction.
	d. Pump locked up by foreign objects.
9.4. Pump runs but gives no liquid.	a. Pump impeller blocked by impurities.
	b. Insufficient liquid level in the tank. (See Sec. 4.1)
9.5. Pump runs but gives no liquid.	a. Suction filter blocked by impurities.
	b. Liquid level is too low (See Sec. 4.1)
	c. Incorrect rotating direction.

TPHK 2T/4T

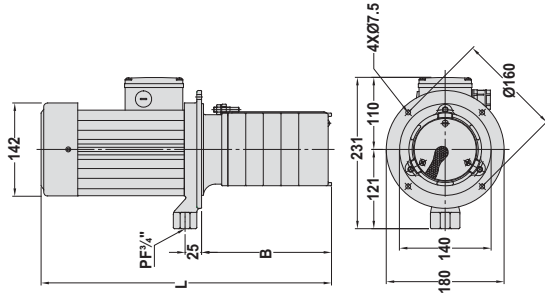

TPHK 8T/12T

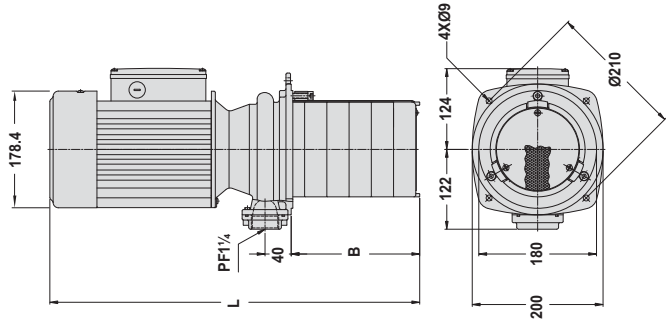

Dimensions and Weights

Model	B (mm)	L (mm)	N.W.(kg)
TPHK 2T 3 -1	145	350	10.9
TPHK 2T 8 -1	235	440	11.9
TPHK 2T 3 -2	145	350	11.1
TPHK 2T 5 -2	181	386	11.5
TPHK 2T 9 -2	253	458	12.3
TPHK 2T 3 -3	145	350	11.2
TPHK 2T 4 -3	163	368	11.4
TPHK 2T 5 -3	181	386	11.6
TPHK 2T 6 -3	199	404	11.8
TPHK 2T 8 -3	235	440	12.2
TPHK 2T11-3	289	494	12.6
TPHK 2T 4 -4	163	368	11.5
TPHK 2T 6 -4	199	404	11.9
TPHK 2T 5 -5	181	426	12.7
TPHK 2T 6 -6	199	444	13.5
TPHK 2T 8 -6	235	480	13.9
TPHK 2T 9 -6	253	498	14.1
TPHK 2T10-6	271	516	14.2
TPHK 2T11-6	289	534	14.4
TPHK 2T 7 -7	217	462	13.0
TPHK 4T 2 -1	145	350	10.8
TPHK 4T 2 -2	145	350	11.0
TPHK 4T 3 -2	172	377	11.2
TPHK 4T 4 -2	199	404	11.4
TPHK 4T 6 -2	253	458	11.6
TPHK 4T 3 -3	172	417	11.7
TPHK 4T 4 -3	199	444	11.9
TPHK 4T 5 -3	226	471	12.1
TPHK 4T 6 -3	253	498	12.3
TPHK 4T 8 -3	307	552	12.7
TPHK 4T 4 -4	199	444	13.3
TPHK 4T 5 -4	226	471	13.5
TPHK 4T 6 -4	253	498	13.7
TPHK 4T 5 -5	226	471	13.9
TPHK 4T 8 -5	307	552	14.5
TPHK 4T 6 -6	253	498	14.1
TPHK 4T 8 -6	307	552	14.6
TPHK 4T 7 -7	280	525	14.6
TPHK 4T 8 -7	307	552	14.8
TPHK 8T 3 -3	95.5	464.5	23.0
TPHK 8T 6 -3	199	568	24.3
TPHK 8T 4 -4	130	499	27.0
TPHK 8T 6 -4	199	568	28.0
TPHK 8T 5 -5	164.5	533.5	28.0
TPHK12T 6 -1	199	568	27.0
TPHK12T 6 -2	199	568	29.0
TPHK12T 6 -3	199	568	30.0

SPKT*R0 trasduttori di pressione raziometrici / ratiometric pressure transducers



I Vi ringraziamo per la scelta fatta, sicuri che sarete soddisfatti del vostro acquisto.



**LEGGI E CONSERVA
QUESTE ISTRUZIONI**
**READ AND SAVE
THESE INSTRUCTIONS**

Caratteristiche generali

Le sonde elettroniche di pressione CAREL sono state sviluppate per essere applicate nei settori della refrigerazione e del condizionamento. La versione raziometrica è disponibile in 5 diversi range di pressione, di seguito riportati.

Descrizione codici e modelli

codice	serigrafia (1)	Pressione (con 5 V) psiA	Pressione (con 5 V) bar (2)	Modello	Materiale	over range
SPKT0053R0	2CP5-52	0 75	-1,0 4,2	femmina	ottone	375,0 24,9
SPKT0013R0	2CP5-46	0 150	-1,0 9,3	femmina	ottone	450,0 30,0
SPKT0043R0	52CP36-01 2CP5-66	15 265	0,0 17,3	femmina	ottone	7895,0 53,8
SPKT0033R0	2CP5-47	15 515	0,0 34,5	femmina	ottone	1030,0 70,0
SPKT0066R0	2CP50-1	15 667	0,0 45,0	femmina	acciaio placcato	1335,0 91,0

⁽¹⁾ per distinguere i trasduttori riferirsi alla serigrafia sul corpo del sensore come da tab.

⁽²⁾ Il range è espresso in bar relativi

Nota: tutti i sensori sono di tipo Sealed Gage.

Accessori

- Cavo con connettore 2 m: SPKC002300 IP55
- Cavo con connettore 5 m: SPKC005300 IP55
- Cavo con connettore 2 m: SPKC002310 IP67
- Cavo con connettore 5 m: SPKC005310 IP67

Collegamenti

Nella Fig. 2 viene indicato lo schema di collegamento della sonda:

- il cavo di colore nero riceve l'alimentazione (5 Vdc);
- il cavo di colore bianco è il segnale di uscita relativo alla pressione letta;
- il cavo di colore verde è il riferimento dell'alimentazione.

Caratteristiche tecniche

alimentazione	4.5...5.5 Vdc
uscita	0.5...4.5 Vdc
filetto connettore	7/16" 20 UNF
condizioni di funzionamento	-40T120 °C
precisione	+/- 1,2% intervallo
errore di temperatura	+/- 0,013%/°C
grado di protezione	IP65
shock (50...2000 Hz)	11g**
grado di inquinamento ambientale	normale
materiale a contatto con il fluido	ottone o acciaio
separazione con membrana	compatibili con fluidi refrigeranti R12, R22, R134A, R404A, R407C, R410A, R502, R50.
plastica	Non compatibili con R717 (ammoniaca), da non usare con acqua e glicole.

** : g= accelerazione di gravità



Thank you for your choice. We trust you will be satisfied with your purchase.

General characteristics

The CAREL electronic pressure probes have been developed for the application in the refrigeration and air conditioning sectors. The ratiometric version is available in 5 different ranges of pressure, as following.

Description of codes and models

code	Silk-screen (1)	Pressure (with 5 V) psiA	Pressure (with 5 V) bar (2)	Model	Body Material	over range
SPKT0053R0	2CP5-52	0 75	-1,0 4,2	female	brass	375,0 24,9
SPKT0013R0	2CP5-46	0 150	-1,0 9,3	female	brass	450,0 30,0
SPKT0043R0	52CP36-01 2CP5-66	15 265	0,0 17,3	female	brass	7895,0 53,8
SPKT0033R0	2CP5-47	15 515	0,0 34,5	female	brass	1030,0 70,0
SPKT0066R0	2CP50-1	15 667	0,0 45,0	female	plated steel	1335,0 91,0

⁽¹⁾ to distinguish the transducers refer to the silk screen on the sensor like shown in the tab.

⁽²⁾ The range is expressed in relative bar

Note: all the sensors are Sealed Gage type.

Accessories

- Cable with connector 2 m: SPKC002300 IP55
- Cable with connector 5 m: SPKC005300 IP55
- Cable with connector 2 m: SPKC002310 IP67
- Cable with connector 5 m: SPKC005310 IP67

Connections

Fig. 2 illustrates the connection diagram of the probe with the male connector:

- the black cable receives power supply (5 Vdc);
- the white cable is the output signal relevant to the read pressure;
- whereas the green cable refers to the power supply.

Technical specifications

power supply	4.5 to 5.5Vdc
output	0.5 to 4.5Vdc
connector thread	7/16" UNF
operating conditions	-40T120°C
precision	+/- 1,2% span
temperature error	+/- 0,013%/°C
protection degree	IP65
shock (50 to 2000Hz)	11g**
environmental pollution level	normal
material in contact with the fluid	brass or plated steel
separation with plastic membrane	compatible with cooling fluids R12, R22, R134A, R404A, R407C, R410A, R502, R50.
	Not compatible with R717 (ammonia), not to be used with water and glycol.

** : g= gravitational acceleration

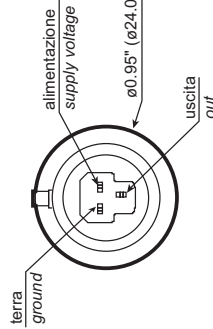
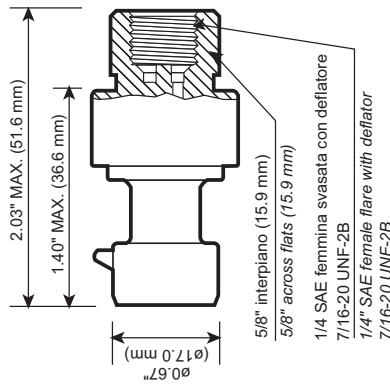

per cavo SPKC* for SPKC* cable: uscita/out = bianco/white
 alimentazione/supply = nero/black
 terra/ground = verde/green

Nota/Note: Campo di temperatura connettore -35T105°C
 Connector temperature range -35T105°C

Esempi di collegamento a strumentazione CAREL / Examples of connection to CAREL instrument

Collegamento con il pCO' / pCO' connection

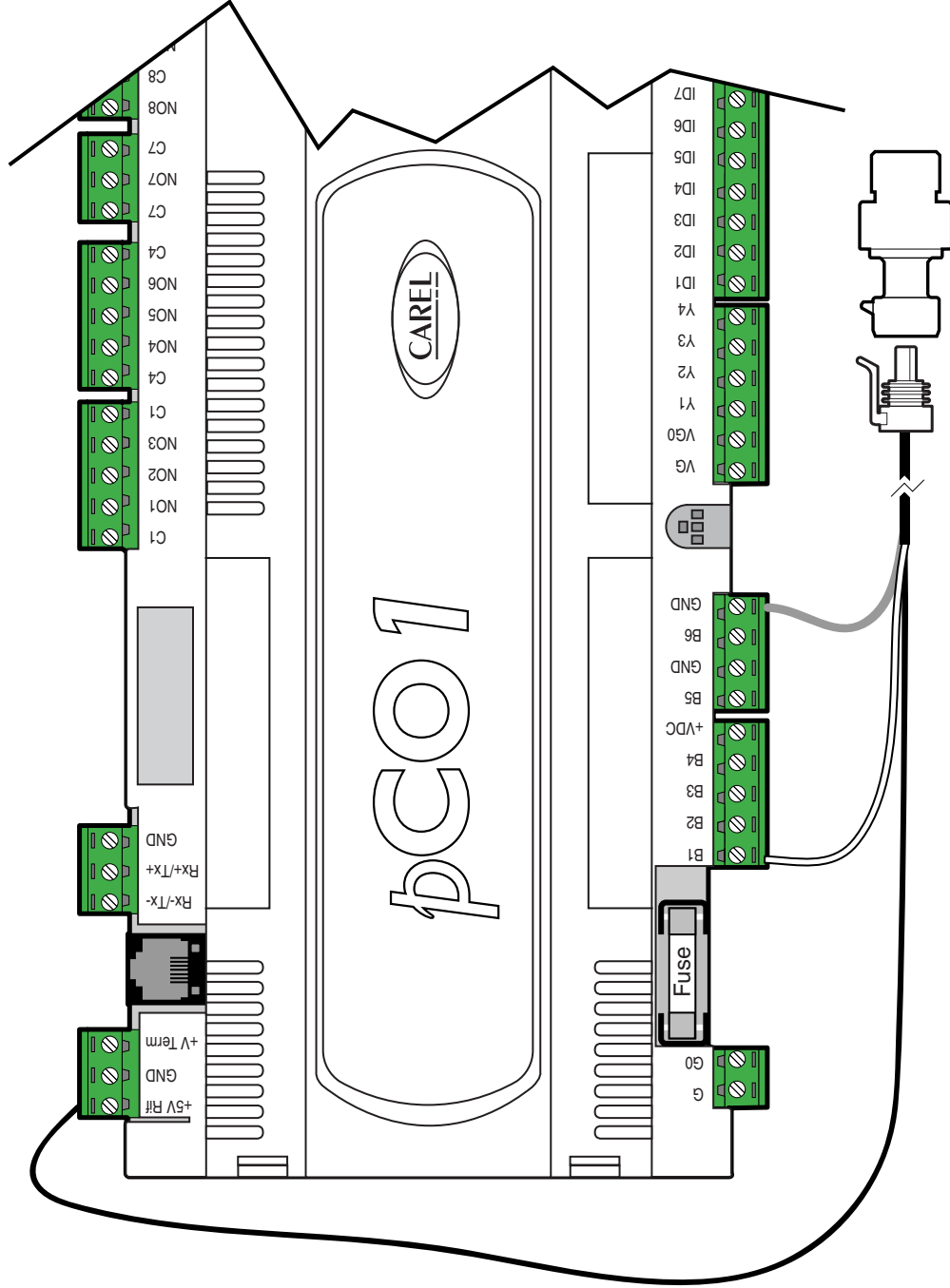

pCO'	Sonda / Probe
Bn= 1, ..., 4	Filo bianco = segnale di pressione White wire = Pressure signal
+5V rif	Filo nero = alimentazione Black wire = power supply
GND	Filo verde = riferimento alimentazione Green wire = supply reference

"L'apparecchiatura (o il prodotto) deve essere oggetto di raccolta separata in conformità alle vigenti normative locali in materia di smaltimento"
 "The appliance (or the product) must be disposed of separately in accordance with the local waste disposal legislation in force"

P266 Series Single-Phase Condenser Fan Speed Control

Installation Instructions

P266xxx-x

Part No. 24-7664-2705, Rev. B

Issued April 29, 2009

Supersedes January 21, 2009

Application

IMPORTANT: Use this P266 Single-Phase Condenser Fan Speed Control only as an operating control. Where failure or malfunction of the P266 fan speed control could lead to personal injury or property damage to the controlled equipment or other property, additional precautions must be designed into the control system. Incorporate and maintain other devices, such as supervisory or alarm systems or safety or limit controls, intended to warn of or protect against failure or malfunction of the P266 fan speed control.



CAUTION: Risk of Property Damage

Use only single-phase Permanent Split Capacitor (PSC) motors approved by the manufacturer for speed control application with the P266 control. Failure to use a single-phase PSC motor may damage the motor and other property.

The P266 Single-Phase Condenser Fan Speed Control is a cost-effective, compact, weather-resistant, and durable speed control for single-phase, PSC motors used in a wide variety of low-ambient refrigeration and air conditioning condenser applications.

The P266 fan speed controls are designed to replace the Johnson Controls® P66 Series and P215 Series Fan Speed Controls and provide additional features and application flexibility.

Mounting

Location and Mounting Considerations

Observe these guidelines when locating and mounting a P266 fan speed control:

- Ensure that the mounting surface and mounting hardware can support the control and wiring.

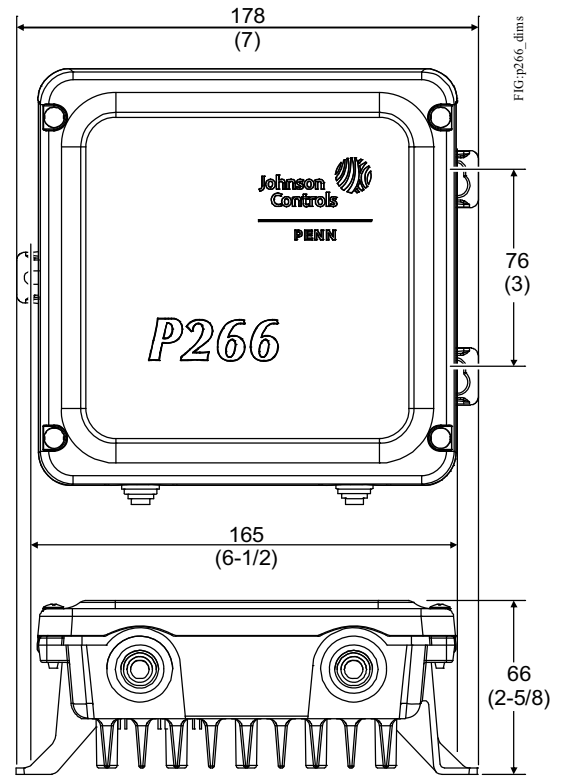

Figure 1: P266 Single-Phase Condenser Fan Speed Control Mounting Dimensions

- Mount the P266 control upright on a vertical surface with the heat sink fins oriented vertically and the conduit/electrical holes facing down.
- Ensure that air can flow through the heat sink fins and provide 10 cm (4 in.) minimum clearance around the heat sink.
- Mount the P266 control in a location away from sources of excessive heat and within the specified ambient operating conditions. See [Technical Specifications](#) for ambient operating conditions.

Wiring

Refer to the model-specific wiring diagram located on the interior label of the P266 control and observe these guidelines when wiring the P266 fan speed control:



WARNING: Risk of Electric Shock.

Disconnect each of multiple power supplies before making electrical connections. More than one disconnect may be required to completely de-energize equipment. Contact with components carrying hazardous voltage can cause electric shock and may result in severe personal injury or death.

IMPORTANT: Do not connect supply power to the P266 fan speed control before finishing wiring and checking all wiring connections. Short circuits or improperly connected wires can result in damage to the P266 control and void any warranty.

IMPORTANT: Do not exceed the P266 fan speed control electrical ratings. Exceeding P266 control electrical ratings can result in permanent damage to the P266 control and void any warranty.

IMPORTANT: Use copper conductors only. Make all wiring in accordance with local, national, and regional regulations.

IMPORTANT: Electrostatic discharge can damage P266 control components. Use proper Electrostatic Discharge (ESD) precautions during installation and servicing to avoid damaging P266 components.

- Ensure that the wires between the P266 control and the fan motor do not exceed 15 m (50 ft).
- Wires connected to the line-voltage terminal block must be 3.31 mm² (12 AWG) or smaller.
- Low-voltage wires must be less than 30 m (100 ft).

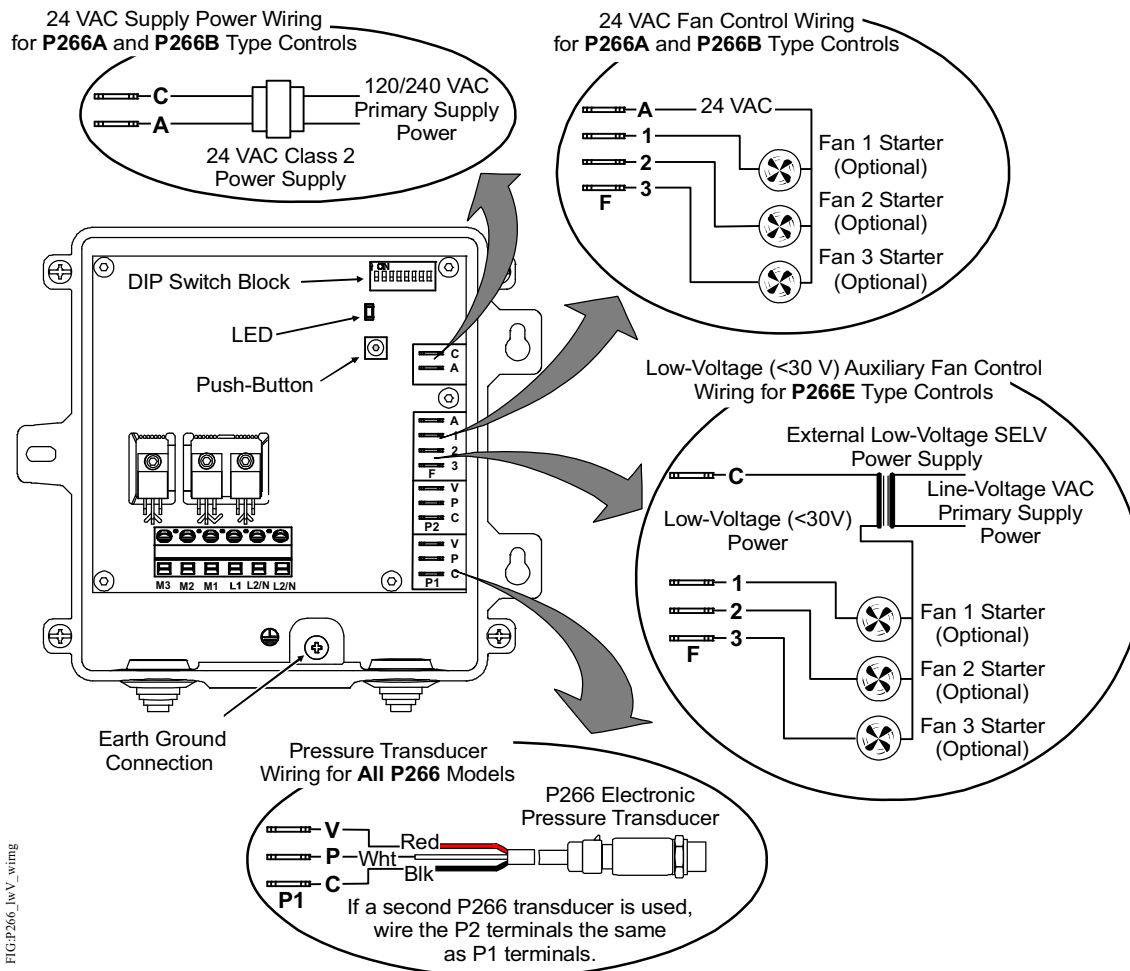

Figure 2: P266 Control Physical Features and Low-Voltage Wiring

Low-Voltage Wiring

Figure 2 shows the P266 control features under the housing cover and the low-voltage wiring diagrams for the P266A, P266B, and P266E Type control models.

High-Voltage Wiring

Figure 3 shows the high-voltage wiring diagrams for the P266A and P266B Type control models. Figure 4 show the high-voltage wiring diagrams for the P266E Type control models.

IMPORTANT: The L2/N terminal must be connected to line voltage in order for a P266 control to comply with the FCC and IEC Class B radio frequency interference emissions limit.

Use Table 1 to determine the high-voltage wiring options available for P266A, P266B, and P266E Type control models.

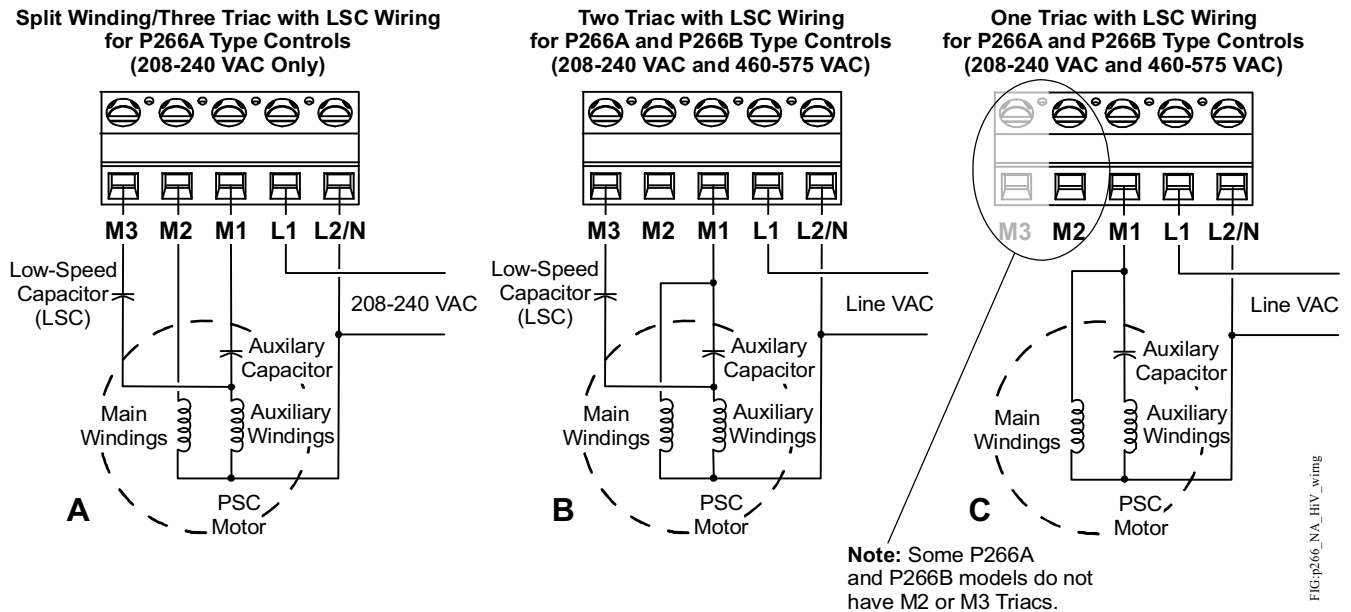

Figure 3: High-Voltage Wiring Options for P266A and P266B Type Controls

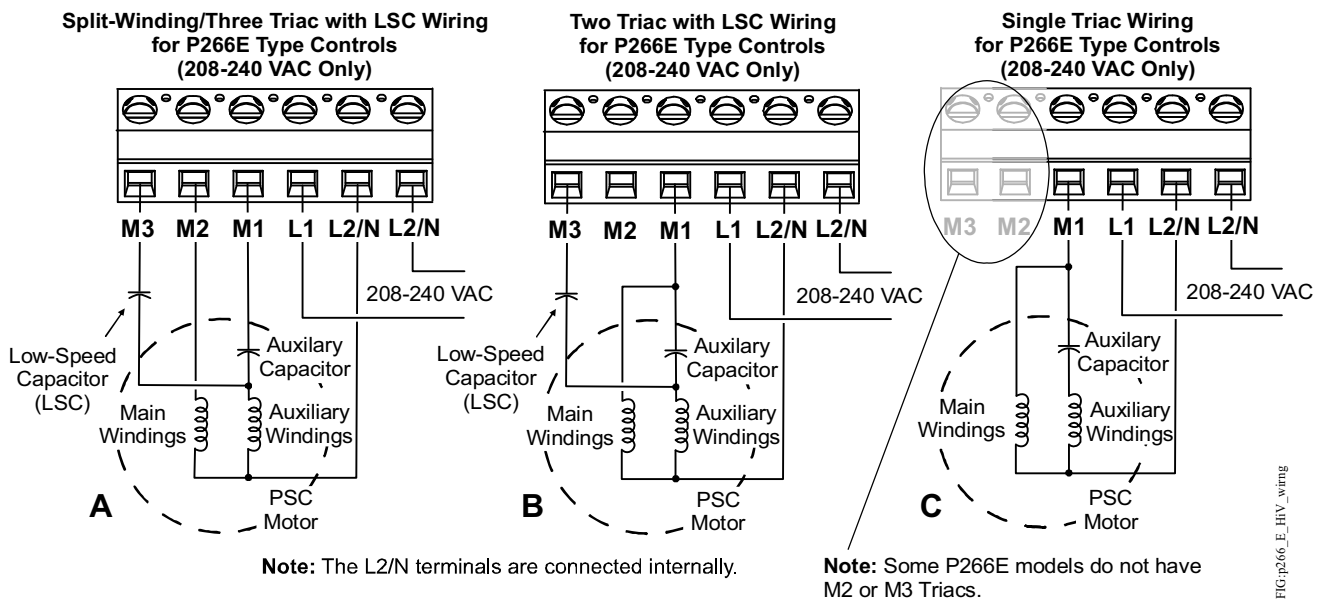

Figure 4: High-Voltage Wiring Options for P266E Type Controls

Table 1: Product Type High-Voltage Wiring Options and Voltage Ranges

Product Type Number	Split Winding/Three Triac with Low-Speed Capacitor Wiring for...		Two Triac with Low-Speed Capacitor Wiring for...		Single Triac Wiring for...	
	208-240 VAC	460-575 VAC	208-240 VAC	460-575 VAC	208-240 VAC	460-575 VAC
P266AA	See Figure 3A	--	See Figure 3B	--	See Figure 3C	--
P266AB	See Figure 3A	--	See Figure 3B	--	See Figure 3C	--
P266AC	--	--	--	--	See Figure 3C	--
P266AD	--	--	--	--	See Figure 3C	--
P266BC	--	--	--	--	--	See Figure 3C
P266BD	--	--	--	--	--	See Figure 3C
P266BG	--	--	--	See Figure 3B	--	See Figure 3C
P266BH	--	--	--	See Figure 3B	--	See Figure 3C
P266EA	See Figure 4A	--	See Figure 4B	--	See Figure 4C	--
P266EB	See Figure 4A	--	See Figure 4B	--	See Figure 4C	--
P266EC	--	--	--	--	See Figure 4C	--
P266ED	--	--	--	--	See Figure 4C	--
P266EE	--	--	--	--	See Figure 4C	--
P266EF	--	--	--	--	See Figure 4C	--

Setup and Adjustments

All P266 controls ship with factory-set default values and mode settings. In most applications, the default values and modes do not require field adjustment.

If your P266 control application requires you to change the value or mode settings, you must:

1. Calculate the new values and determine the new mode settings required for your application. (See [P266 Control Values and Modes](#).)
2. Change the existing settings on the control to the new values and modes using the P266 control setup interface. (See [Setting Values and Modes](#).)

P266 Control Setup Interface

The P266 control setup interface consists of a DIP switch block with eight binary switches, a push button switch, and a green Light-Emitting Diode (LED) (Figure 2). You can change the factory-set default values and modes by repositioning the DIP switches and saving the new settings. The number of LED flashes (in sequence) indicates which value and/or modes that you are saving. See Table 2 for more information about LED flash sequences, values, and modes.

During normal operation, the green LED is On/lit constantly. When you **press and hold** the push button, the LED goes Off for 3 seconds then flashes two times. The LED then goes Off again for 3 seconds and flashes three times, and continues this pattern until seven flashes or until you release the push button.

Each sequence of flashes indicates a value or a value and set of mode settings. Releasing the push button after the desired flash sequence saves the value and/or modes that are currently set on the DIP switch block. See Table 2 for more information.

P266 Control Values and Modes

P266 controls have up to ten values and modes (in six flash sequences) that can be changed in the field. See Table 2 for more information about flash sequences and the associated values and modes.

Start Voltage Value

The start voltage (VAC) is the voltage delivered by the P266 control to the fan motor to run the motor at minimum speed in your application.

The **Start Voltage value** is a percentage of the P266 control's input voltage. Use the following formula to calculate the Start Voltage value for your application.

$$\frac{\text{Start Voltage (VAC)}}{\text{P266 Control Input Line- Voltage (VAC)}} = \text{Start Voltage Value (\%)}$$

Low Pressure Mode

Low Pressure Mode determines whether the fan motor is either On (at start voltage/minimum speed) or Off when the sensed pressure at the P266 transducer is below the start pressure setpoint.

Start Pressure Value

Start pressure (psi or bar) is the pressure setpoint at which the P266 control outputs the start voltage and runs the fan motor at minimum speed. **Start Pressure value** is a function of the start pressure setpoint and the pressure range of the referenced P266 transducer. Use the following formula to calculate the Start Pressure value. See Table 3 for P266 transducer pressure ranges.

$$\frac{\text{Start Pressure Setpoint (bar or psi)}}{\text{P266 Transducer Pressure Range (bar or psi)}} \times 250 = \text{Start Pressure Value}$$

End Pressure Value

The end pressure setpoint is the pressure (bar or psi) at which the P266 control outputs the End Voltage and runs the fan motor at maximum speed. **End Pressure value** is a function of the end pressure setpoint and the total pressure range of the referenced transducer. Use the following formula to determine your application End Pressure value. See Table 3 for P266 transducer pressure ranges.

$$\frac{\text{End Pressure Setpoint (bar or psi)}}{\text{P266 Transducer Pressure Range (bar or psi)}} \times 250 = \text{End Pressure Value}$$

Split Winding Mode

Some single-phase PSC motors have split motor winding wire leads. Setting the Split Winding mode On enables the M2 Triac to provide voltage to the main windings (and not the auxiliary windings), which increases motor efficiency (Figure 3A and Figure 4A).

Note: Split Winding mode is available for **only 240 VAC single-phase PSC motors that have split winding wire leads**. Refer to the motor manufacturer's installation instructions to determine if your fan motor may be wired to enabled the Split Winding mode.

End Voltage Mode

End voltage is the voltage output by the P266 control (as a percentage of the full voltage) that is maintained when the monitored pressure is equal to or greater than the End Pressure. The End Voltage mode can be set to either 95% or 97% of the total input voltage.

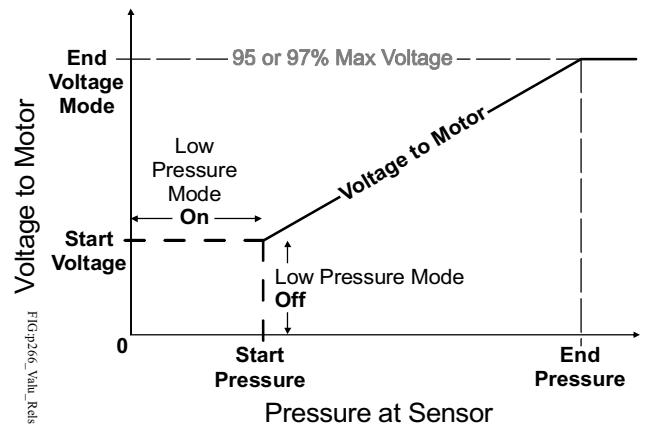

Figure 5: Graph Showing the Relationship between P266 Fan Speed Control Variables

Low-Speed Capacitor Mode

In some fan speed applications, a (user-supplied) Low-speed capacitor (LSC) can be connected to the P266 control's M3 triac and the controlled fan motor (Figure 3 and Figure 4). The low-speed capacitor is enabled at low voltages to enhance the fan motor efficiency and performance. Set Low-speed Capacitor mode On when a low-speed capacitor is used.

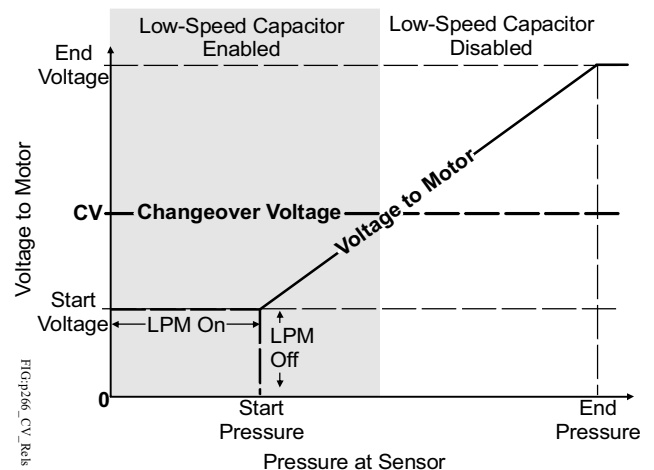

Figure 6: Low-Speed Capacitor Operation

Note: The optional low-speed capacitor should be equal in both the voltage range and the microfarad value to the auxiliary capacitor supplied by the manufacturer, but the capacitor must not exceed 15 microfarads.

Note: You must also set the Changeover Voltage value when a low-speed capacitor is used in your P266 control application. See [Changeover Voltage Value](#) and [Determining Changeover Voltage Value](#) for more information on setting the Changeover Voltage value.

Auxiliary Fan Stage Mode

You can set the P266 fan speed control to cycle (On/Off) up to three additional (fixed-speed) fan motors or fan stages in conjunction with the variable speed fan controlled by the P266 control.

Three low-voltage circuits (Figure 2) can be wired to control the auxiliary fan motor/stage starters. See Table 2 for information on setting the number of auxiliary fans used in your application.

Figure 7 shows a P266 control application with one auxiliary fan operating in conjunction with the speed-controlled fan. When the condenser load exceeds the output capacity of the speed-controlled fan, the P266 control powers On the auxiliary fan and shifts the speed-controlled (P266) fan to a new start pressure.

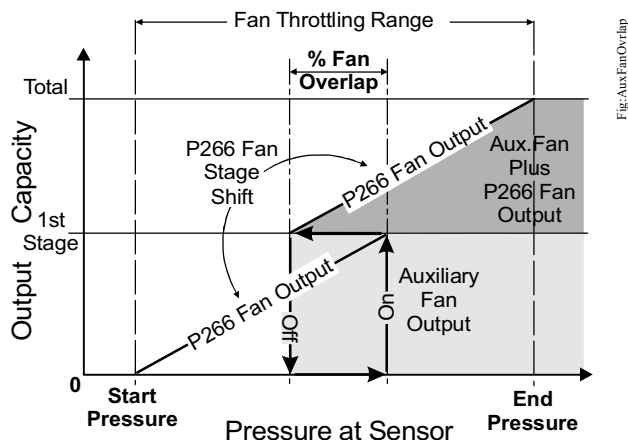

Fig:AuxFanOverlap

Figure 7: Graph Showing a Speed-Controlled (P266) Fan Operating with One Auxiliary (On/Off) Fan Stage over the Entire Pressure Range

Auxiliary Fan Overlap Value

Auxiliary Fan Overlap value determines the pressure range overlap (as a percentage of the total pressure [throttling] range) between the fan stages set up on the P266 control. The fan overlap value is equal for all auxiliary fan stages set up on the control.

Increasing the Auxiliary Fan Overlap value decreases the (On/Off) cycling rate of the auxiliary fans and increases the pressure differential between auxiliary fan stages (which increases the pressure range of each auxiliary fan stage).

Note: If the P266 control is set for no auxiliary fans, the Auxiliary Fan Overlap value is not used. See Table 2 for information on setting the number of auxiliary fans used in your application.

Changeover Voltage Value

The Changeover Voltage value determines the voltage at which the P266 control enables and disables the M3 triac and the low-speed capacitor (Figure 6). See [Determining Changeover Voltage Value](#).

Setting Values and Modes

To change settings and values on a P266 control:

1. Determine the operating pressure setpoints (psi or bar), voltage inputs and outputs (VAC), and the other modes of operation required for your condenser fan motor control application.
 2. Convert the selected pressure setpoints (psi or bar) and voltage targets (VAC) into P266 control values. See [P266 Control Values and Modes](#) and Table 2.
 3. Position the DIP switches to set the new values and/or modes. See [Setting up the DIP Switch Block](#).
 4. Press and hold the push button until the number of LED flashes indicates the desired value or set of values and/or mode settings. Release the push button **after**:
 - **two flashes** to save the Low Pressure mode setting and the Start Voltage value
 - **three flashes** to save the Start Pressure value
 - **four flashes** to save the End Pressure value
 - **five flashes** to save the Split Winding, End Voltage, Low-speed Capacitor Mode, and Auxiliary Fan Stages mode settings
 - **six flashes** to save the Auxiliary Fan Overlap value
 - **seven flashes** to save the Changeover Voltage value
- Note:** See Table 2 for more information about the values and modes that are associated with the number of LED flashes.
5. Repeat Steps 3 and 4 for the next value and/or mode you need to change.
 6. After you save all of the new values and mode settings, set all of the DIP switches to the On position to lock out the push button operation.

Setting up the DIP Switch Block

To set new values and modes on the DIP switch block:

1. Position all of the switches on the DIP switch block to the Off position.
2. Position the numbered switches to ON so that the total of the switch numbers (in the ON position) equals the desired setup value. Start with the highest number switch that is less than the setup value. (For example, if the desired setup value is 185, position switch 128 to ON first. Then position switch 32 ON, followed by switch 16, switch 8, and switch 1 [$128+32+16+8+1=185$] [Figure 8]).

Mode settings require you to position only one or two switches on the DIP switch block, depending on the mode. See Table 2 for more information about the values and modes that are associated with the number of LED flashes.

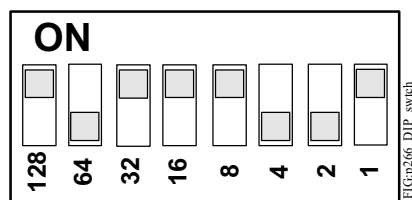

Figure 8: A DIP Switch Block with the Switches Positioned for a Setup Value of 185

IMPORTANT: All of the switches on the DIP switch block must be set to the proper positions for your application before you press and release the push button to save the values and/or mode settings. See Table 2 for more information on switch positions.

Test Voltage Mode

Test Voltage mode is a setup and diagnostic tool in the P266 control firmware that allows you to test a condenser fan motor's operation at different voltage values in the field and determine the optimal Start Voltage value for your P266 control application.

Test Voltage mode also allows you to determine and set the optimal Changeover Voltage value for the M3 triac in P266 control applications that use a low-speed capacitor.

To use the Test Voltage Mode, you need:

- a P266 control model designed for your condenser fan application
- access to the condenser (and fan motor) controlled by your P266 control
- a clamp-on ampere meter with 15 A range (to check changeover current draw when determining Changeover Voltage value)
- an insulated probe to hold down the push-button and change the DIP switch positions
- a 24 VAC Class 2 power supply (**only** for P266 control models that require an external 24 VAC power supply)
- a Low-Speed Capacitor (LSC), sized for the fan motor (**only** for P266 control applications that use a low-speed capacitor)

Note: The LSC should be equal in both the voltage range and the microfarad value to the motor manufacturer's auxiliary capacitor, but the LSC must not exceed 15 microfarads.

Setting up Test Voltage Mode

Before you power on a P266 control and enable the Test Voltage mode on the control:

1. Read and follow the guidelines and procedures in the *Mounting* and *Wiring* sections.
2. Mount and wire the P266 control in your condenser application and observe these additional guidelines:
 - Refer to the label inside the P266 control housing cover for model-specific wiring details. See *Wiring* for some wiring options.
 - Wire the auxiliary and main windings according to the motor manufacturer's instructions and your application requirements. Split the windings (at the winding leads) and power them separately, if your application and motor allow for split-winding operation. See Figure 3 and Figure 4.

- If your application uses an optional low-speed capacitor, wire the LSC to the M3 triac and motor **only** after you have checked and recorded the current draw at maximum. See [Determining Changeover Voltage Value](#).
 - If your P266 control model requires an external 24 VAC power supply for control operation, wire that power supply to the control. (Refer to the wiring label inside the P266 control cover for external power supply requirements.)
 - You do **not** have to connect, wire, or power the P266 transducer, or put a load on the condenser to operate a P266 control in the Test Voltage mode. Test Voltage mode allows you to use the DIP switch to set the voltage supplied to the motor by the P266 control.
3. Set up the P266 control and the condenser fan motor for the intended operation, by setting the required values and modes of operation for your condenser fan application. See [Setup and Adjustments](#) for procedures.

Determining Changeover Voltage Value

In the Test Voltage mode, you can determine and set the Changeover Voltage value for P266 control applications that use an optional low-voltage capacitor. To determine and set the Changeover Voltage value:

1. Mount, wire, and set up the P266 control and the condenser fan motor for operation in the Test Voltage mode. See [Setting up Test Voltage Mode](#).

Note: Do **not** wire the low-speed capacitor until Step 5 of this procedure.
2. Set all of the DIP switches except switch 1 to the ON position; set switch 1 to Off.
3. Apply line-voltage power to the P266 control (and the external 24 VAC power supply on required models), then, within the first 30 seconds after applying power, press and release the push button three times. The LED goes off and stays off, and the fan motor accelerates to maximum speed (at 95 or 97% of maximum voltage) and stays at the maximum voltage for up to 5 minutes.
4. At maximum voltage, use the clamp-on ampere meter to check the current draw (in amperes) of the fan motor auxiliary windings and record the auxiliary windings current draw for the motor at maximum voltage.
5. Disconnect line-voltage power to the P266 (and the external 24 VAC power supply on required models).
6. Wire the low-speed capacitor to the M3 triac and the motor auxiliary windings. (See Figure 3 and Figure 4 for M3 triac wiring options.)
7. Set all of the DIP switches except switches 8 and 32 to the Off position; set switches 8 and 32 to the ON position. (8 + 32 = 40% of maximum voltage value.)
8. Apply line-voltage power to the P266 control (and the external 24 VAC power supply on required models), then, within the first 30 seconds after applying power, press and release the push button three times. The LED goes off and stays off, and the fan motor accelerates to the speed at 40% of the maximum voltage (for up to 5 minutes).
9. At 40% of maximum voltage, use the clamp-on ampere meter to check the current draw (in amperes) of the low-speed capacitor lead connected to the M3 terminal and record the current draw for the low-speed capacitor lead at 40% voltage.
10. Repeat Step 7 but increase the percent voltage value by 8%, then repeat Step 8, Step 9, and Step 10 at the increased voltage values until the current draw equals the (maximum voltage) current draw recorded in Step 4.

Note: If the motor stops or does not run smoothly, reduce the voltage value on the DIP switches by 4% and test the motor operation.
11. The DIP switch voltage value is now equal to the highest voltage of the low-speed mode or the Changeover Voltage value.
12. Press and hold the push button until the LED flashes 3 time, then release the button. The Changeover Voltage value is set and saved on the P266 control.

Note: If you want to also determine and set the Start Voltage value for your P266 control and motor, you can go directly to Step 3 of the [Determining Start Voltage Value](#) procedure.
13. Disconnect power to the P266 control and set all of the DIP switches to the On position to lock out the push button operation.
14. Reconnect power to the P266 control to resume normal motor speed control.

Determining Start Voltage Value

In the Test Voltage mode, you can also determine and set the Start Voltage value on for P266 control application.

To determine and set the Start Voltage value:

1. Mount, wire, and set up the P266 control and the condenser fan motor for operation in the Test Voltage mode. See [Setting up Test Voltage Mode](#).
Note: If your application uses Split Winding mode and Low Speed Capacitor mode, wire the split windings and low-speed capacitor according to your application requirements (Figure 3A and Figure 4A).
2. Apply line-voltage power to the P266 control (and the external 24 VAC power supply on required models), then, within the first 30 seconds after applying power, press and release the push button three times. The LED goes off and stays off.
3. Position the DIP switches so that the total value of the switches positioned ON is equal to a percentage value equal to or slightly higher than your estimated Start Voltage value. (For example, if you estimate the start voltage of the motor to be 25% of the total voltage, position switches 16, 8, 4, and 2 ON. $16 + 8 + 4 + 2 = 30\%$, which is slightly higher than your 25% estimate.) The fan motor accelerates to the speed at 30% of maximum voltage and stays at that speed.

4. Observe the fan motor operation and determine if the applied start voltage runs the motor at the desired start speed:
 - If the start speed and motor operation meet your application requirements, go to Step 5.
 - If the start speed or operation does not meet your application requirements, return to Step 3 and set a new estimated Start Voltage value to generate the desired motor start speed.
5. When your motor is running at the desired start speed (Start Voltage value), press and hold the push button until the LED flashes 2 times in succession, then release the push button. The Start Voltage value is set and saved on the P266 control.
6. Disconnect power to the P266 control and set all of the DIP switches to the On position to lock out the push button operation.
7. Reconnect power to the P266 control to resume normal motor speed control.

Table 2: LED Flash Sequences, Setup Values, Mode Settings on DIP Switch Block and Default Values and Mode Settings and Mode Settings Example

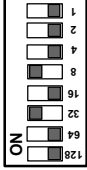
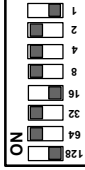
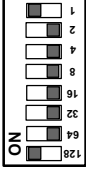
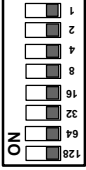
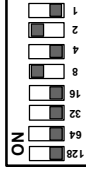
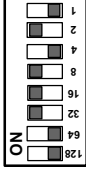
Release Push Button After...	Value/Mode Name (Binary Switch Number)	Value Range/Mode Settings (Example Default Settings)	Switch Number and Position Description of Value/Setting	DIP Switch Block Example Default Settings
Two Flashes	Low Speed Mode (Switch 128)	Settings: ON or Off (Default Setting: Off)	Switch 128 Off = No voltage to motor when sensed pressure is below start pressure. Switch 128 ON = Start voltage to motor when sensed pressure is at or below start pressure.	
	Start Voltage Value (Switches 1 to 64)	Value Range: 10 to 90 (Default Value: 40)	Position Switches 1 to 64 ON or Off so that the sum of the switches set to ON equals the Start Voltage Value.	
Three Flashes	Start Pressure Value (Switches 1 to 128)	Value Range: 10 to 230 (Default Value: 110)	Position Switches 1 to 128 ON or Off so that the sum of the switches set to ON equals the Start Pressure Value.	
	End Pressure Value (Switches 1 to 128)	Value Range: [Start Pressure + 8] to 240 (Default Value: 129)	Position the Switches 1 to 128 ON or Off so that the sum of the switches set to ON equals the End Pressure Value.	
Five Flashes (Switches 64 and 128 Off)	Split Winding Mode (Switch 32)	Settings: ON or Off (Default Setting: Off)	Switch 32 ON = M2 Triac enabled to power split windings. Switch 32 Off = M2 Triac is disabled.	
	End Voltage Mode (Switch 16) (Future Function) (Switch 8)	Settings: ON or Off (Default Setting: Off)	Switch 16 ON = Provides 95% of P266 input voltage to motor. Switch 16 Off = Provides 97% of P266 input voltage to motor.	
		Settings: ON or Off (Default Setting: Off)	Switch 8 ON = (Do not set to ON position.) Switch 8 Off = Set switch to Off position.	
	Low Speed Capacitor Mode (Switch 4)	Settings: ON or Off (Default Setting: Off)	Switch 4 ON = Low speed capacitor is available. Switch 4 Off = Low speed capacitor is not available.	
	Number of Auxiliary Fan Stages (Switches 1 and 2)	Settings: ON or Off (Default Setting: Off - Off)	Position switches 1-Off and 2-Off for no auxiliary fans. Position switches 1-On and 2-Off for auxiliary fan 1. Position switches 1-Off and 2-On for auxiliary fans 1 and 2. Position switches 1-On and 2-On for auxiliary fan 1, 2, and 3.	
		Value Range: 1 to 90 (Default Value: 10)	Position Switches 1 to 64 ON or Off so that the sum of the switches set to ON equals the Auxiliary Fan Overlap Value.	
Seven Flashes (Switch 128 Off)	Changeover Voltage Value (Switch 1 to 64)	Value Range: 10 to 80 (Default Value: 60)	Position Switches 1 to 64 ON or Off so that the sum of the switches set to ON equals the Changeover Voltage value.	

P266 Electronic Pressure Transducers

P266 controls are designed to reference either one or two Johnson Controls P266 Electronic Pressure Transducers to monitor condenser pressure.

P266 transducers are specialized versions of the P499 Series Electronic Pressure Transducers designed for use with P266 fan speed controls. See Table 3 for the available P266 transducer models.

Note: On P266 control applications that use two P266 transducers, the P266 control always references the transducer that is sensing the highest pressure.

IMPORTANT: When two P266 transducers are connected to a P266 control, the transducers must be the same model (product code number). Failure to connect the same P266 transducer models to the P266 control can result in erratic control behavior.

Refer to the *P499 Series Electronic Pressure Transducers Product/Technical Bulletin (LIT-1201190)* for information on installing P266 transducers.

Table 3: P266SNR Electronic Pressure Transducers

Product Code Number	Description
P266SNR-1C	Electronic Pressure Transducer: 0 to 35 bar (0 to 508 psi) total range with a 1/4 in. SAE Female Flare connection and a 2 meter (3.1 ft) cable.
P266SNR-2C	Electronic Pressure Transducer: 0 to 52 bar (0 to 754 psi) total range with a 1/4 in. SAE Female Flare connection and a 2 meter (3.1 ft) cable.

Technical Specifications

P266xxx-x

Product	P266xxx-x Single Phase Condenser Fan Speed Control
Input Supply Power	208-240 VAC 50/60 Hz or 480-575 VAC 50/60 Hz depending on model (Refer to the label inside the P266 control housing cover for rated voltage range and model-specific wiring diagram.)
Low-Voltage Power Supply	P266A and P266B Types: External 24 VAC Class 2, 20 VA Supply Transformer P266Exx Types: Low-voltage power for P266 control is provided by an onboard transformer. Note: When auxiliary fan starters are connected to P266E type controls, you must provide an external Safety Extra-Low Voltage (SELV) AC supply to power the fan starters (Figure 2).
Ambient Operating Conditions	Temperature: -20 to 60°C (-4 to 140°F) Humidity: Up to 95% RH non-condensing; Maximum Dew Point 29°C (85°F)
Ambient Shipping and Storage Conditions	Temperature: -40 to 85°C (-40 to 185°F) Humidity: Up to 95% RH non-condensing; Maximum Dew Point 29°C (85°F)
Low-Voltage Connections	1/4 in. Quick-Connect terminals, 30 m (100 ft) maximum wiring runs
Input Transducer	P266SNR-x Pressure Transducer: 5 VDC for 0.5 to 4.5 VDC ratio metric analog signal
Enclosure Type	NEMA 3R, IP54
Case Construction	Aluminum Die Casting
Cover Construction	UV Stabilized Polycarbonate/ABS
Dimensions (HxWxD)	159 x 177 x 70 mm (6-1/4 x 7 x 2-3/4 in.)
Weight	Heaviest Model Weight: 1.0 kg (2.2 lb) Approximate Shipping Weight: 1.2 kg (2.6 lb)
Compliance	Europe: Mark: CE Compliant; CENELEC EN 60947-1 & 4-2; RoHS Directive (2002/95/EC); WEEE Directive (2002/96/EC) North America: ETL, UL508C; cETL C22.2 No. 107.1; FCC Compliant to CFR47, Part 15, Subpart B, Class B Industry Canada (IC) Compliant to Canadian ICES-003, Class B limits Australia: C-Tick Compliant (N1813)

The performance specifications are nominal and conform to acceptable industry standards. For application at conditions beyond these specifications, consult Johnson Controls Application Engineering at (414) 524-5535. Johnson Controls, Inc. shall not be liable for damages resulting from misapplication or misuse of its products.

United States Emissions Compliance (FCC)

This equipment has been tested and found to comply with the limits for a Class B digital device, pursuant to Part 15 of the FCC Rules. These limits are designed to provide reasonable protection against harmful interference in a residential installation. This equipment generates, uses and can radiate radio frequency energy and, if not installed and used in accordance with the instructions, may cause harmful interference to radio communications. However, there is no guarantee that interference will not occur in a particular installation. If this equipment does cause harmful interference to radio or television reception, which can be determined by turning the equipment off and on, the user is encouraged to try to correct the interference by one or more of the following measures:

- Reorient or relocate the receiving antenna.
- Increase the separation between the equipment and receiver.
- Connect the equipment into an outlet on a circuit different from that to which the receiver is connected.
- Consult the dealer or an experienced radio/TV technician for help.

Canadian Emissions Compliance

*This Class (B) digital apparatus meets all the requirements of the Canadian Interference-Causing Equipment Regulations.
Cet appareil numérique de la Classe (B) respecte toutes les exigences du Règlement sur le matériel brouilleur du Canada.*



Building Efficiency
507 E. Michigan Street, Milwaukee, WI 53202

*Metasys® and Johnson Controls® are registered trademarks of Johnson Controls, Inc.
All other marks herein are the marks of their respective owners. © 2009 Johnson Controls, Inc.*

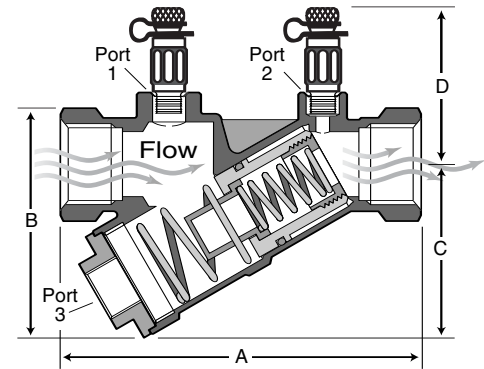

Model YR shown with standard Pressure / Temperature ports.

Product Information

Body:	DZR Brass
Flow Cartridge:	Series 300 Stainless Steel Wear Surfaces with Stainless Steel Spring
Accuracy:	±5%
Rating:	400 psig at 250° F (25 bar at 120° C)

AutoFlow regulator, factory set to automatically limit the flow to within 5% of the specified amount over 95% of the control range. The flow cartridge is removable from the valve body to provide access for regulator changeout, inspection and cleaning without breaking the main piping. Internal wear surfaces of the valve cartridge are stainless steel. Pressure / Temperature ports are standard.

Dimensions not to be used for construction unless prints certified by factory.

Dimensions

Model	Size in./ (mm)	A in./ (mm)	B in./ (mm)	C in./ (mm)	D in./ (mm)	Weight lb./ (kg)	Cv / (Kv)	Maximum gpm (lps) [†] Control Range psid (kPa)	
								2-32 (14-220)	5-60 (35-414)
YR0050S	1/2 (15)	3.7 (93)	2.3 (59)	1.9 (49)	2.2 (55)	0.9 (0.41)	7.6 (8.8)	8 (0.5)	12 (0.8)
YR0050F	1/2 (15)	4.0 (101)	2.5 (64)	1.9 (49)	2.2 (55)	0.9 (0.41)	7.6 (8.8)	8 (0.5)	12 (0.8)
YR0075S	3/4 (20)	4.1 (103)	2.5 (63)	1.9 (49)	2.2 (55)	1.0 (0.45)	8.7 (10.1)	8 (0.5)	12 (0.8)
YR0075F	3/4 (20)	4.2 (106)	2.6 (67)	1.9 (49)	2.2 (55)	1.0 (0.45)	8.7 (10.1)	8 (0.5)	12 (0.8)
YR0100S	1 (25)	5.3 (136)	3.2 (80)	2.5 (64)	2.3 (58)	1.9 (0.86)	15.3 (17.7)	18 (1.1)	26 (1.6)
YR0100F	1 (25)	5.5 (140)	3.4 (86)	2.5 (64)	2.3 (58)	1.9 (0.86)	15.3 (17.7)	18 (1.1)	26 (1.6)
YR0125F	1 1/4 (32)	5.8 (148)	3.6 (90)	2.5 (64)	3.1 (80)	2.1 (0.95)	15.2 (17.6)	18 (1.1)	26 (1.6)
YR0150F	1 1/2 (40)	7.0 (177)	5.3 (134)	4.1 (104)	2.5 (64)	4.0 (1.81)	38.7 (44.7)	50 (3.2)	70 (4.4)
YR0200F	2 (50)	7.1 (179)	5.5 (140)	4.1 (104)	2.8 (70)	6.0 (2.04)	42.1 (48.7)	50 (3.2)	70 (4.4)
YR0250F	2 1/2 (65)	9.1 (230)	7.0 (177)	5.2 (132)	2.9 (73)	9.0 (3.63)	87.2 (100.8)	80 (5.0)	120 (7.6)

Notes

Weights based on F X F connections and will vary with mixed options/connections.

All weights and dimensions are subject to minor changes.

Cv's based on component body without flow regulator.

†For pump head calculations, add the indicated pressure drop of 4.6 ft (14 kPa) for 2-32 (14-220) or 11.6 ft (35 kPa) for 5-60 (35-414) to calculated drops for other components

1 1/4" - 2 1/2" available with sweat adaptor

Available in ISO7

3 ports only available

S = female sweat F = female NPT

Flow Rates

Size	psid Range	Flow Rate (gpm)
1/2" - 3/4"	2 - 32	0.5, 0.75, 1.0, 1.25, 1.5, 1.75, 2.0, 2.25, 2.5, 3.0, 3.5, 4.0, 4.5, 5.0, 6.0, 7.0, 8.0
	5 - 60	1.0, 1.5, 2.0, 2.5, 3.0, 4.0, 5.0, 6.0, 7.0, 8.0, 9.0, 10, 11, 12
1" - 1 1/4"	2 - 32	0.5, 0.75, 1.0, 1.25, 1.5, 1.75, 2.0, 2.25, 2.5, 3.0, 3.5, 4.0, 4.5, 5.0, 6.0, 7.0, 8.0, 9.0, 10, 11, 12, 13, 14, 15, 16, 17, 18
	5 - 60	1.0, 1.5, 2.0, 2.5, 3.0, 4.0, 5.0, 6.0, 7.0, 8.0, 9.0, 10, 11, 12, 13, 14, 15, 16, 17, 18, 19, 20, 21, 22, 23, 24, 25, 26
1 1/2" - 2"	2 - 32	5.0, 6.0, 7.0, 8.0, 9.0, 10, 11, 12, 13, 14, 15, 16, 17, 18, 20, 22, 24, 26, 28, 30, 32, 34, 36, 38, 40, 42, 44, 46, 48, 50
	5 - 60	8.0, 9.0, 10, 11, 12, 13, 14, 15, 16, 17, 18, 19, 20, 21, 22, 23, 24, 25, 26, 28, 30, 32, 34, 36, 38, 40, 42, 44, 46, 48, 50, 52, 54, 56, 58, 60, 62, 64, 66, 68, 70
2 1/2"	2 - 32	9.0, 10, 11, 12, 13, 14, 15, 16, 17, 18, 20, 22, 24, 26, 28, 30, 32, 34, 36, 38, 40, 42, 44, 46, 48, 50, 52, 56, 60, 64, 68, 72, 76, 80
	5 - 60	13, 14, 15, 16, 17, 18, 19, 20, 21, 22, 23, 24, 25, 26, 28, 30, 32, 34, 36, 38, 40, 42, 44, 46, 48, 50, 52, 54, 56, 58, 60, 62, 64, 66, 68, 70, 72, 76, 80, 84, 88, 92, 96, 100, 104, 108, 112, 116, 120

Size	kPa Range	Flow Rate (lps)
15 - 20 mm	14 - 220	0.03, 0.05, 0.06, 0.08, 0.09, 0.11, 0.13, 0.14, 0.16, 0.19, 0.22, 0.25, 0.28, 0.32, 0.38, 0.44, 0.50
	35 - 414	0.06, 0.09, 0.13, 0.16, 0.19, 0.25, 0.32, 0.38, 0.44, 0.50, 0.57, 0.63, 0.69, 0.76
25 - 32 mm	14 - 220	0.03, 0.05, 0.06, 0.08, 0.09, 0.11, 0.13, 0.14, 0.16, 0.19, 0.22, 0.25, 0.28, 0.32, 0.38, 0.44, 0.50, 0.57, 0.63, 0.69, 0.76, 0.82, 0.88, 0.95, 1.01, 1.07, 1.14
	35 - 414	0.06, 0.09, 0.13, 0.16, 0.19, 0.25, 0.32, 0.38, 0.44, 0.50, 0.57, 0.63, 0.69, 0.76, 0.82, 0.88, 0.95, 1.01, 1.07, 1.14, 1.20, 1.26, 1.32, 1.39, 1.45, 1.51, 1.58, 1.64
40 - 50 mm	14 - 220	0.32, 0.38, 0.44, 0.50, 0.57, 0.63, 0.69, 0.76, 0.82, 0.88, 0.95, 1.01, 1.07, 1.14, 1.26, 1.39, 1.51, 1.64, 1.77, 1.89, 2.02, 2.15, 2.27, 2.40, 2.52, 2.65, 2.78, 2.90, 3.03, 3.15
	35 - 414	0.50, 0.57, 0.63, 0.69, 0.76, 0.82, 0.88, 0.95, 1.01, 1.07, 1.14, 1.20, 1.26, 1.32, 1.39, 1.45, 1.51, 1.58, 1.64, 1.77, 1.90, 2.02, 2.15, 2.27, 2.40, 2.52, 2.65, 2.78, 2.90, 3.03, 3.15, 3.28, 3.41, 3.53, 3.66, 3.79, 3.91, 4.04, 4.16, 4.29, 4.42
65 mm	14 - 220	0.57, 0.63, 0.69, 0.76, 0.82, 0.88, 0.95, 1.01, 1.07, 1.14, 1.26, 1.39, 1.51, 1.64, 1.77, 1.89, 2.02, 2.15, 2.27, 2.40, 2.52, 2.65, 2.78, 2.90, 3.03, 3.15, 3.28, 3.41, 3.53, 3.66, 3.79, 3.91, 4.04, 4.16, 4.29, 4.42, 4.54, 4.79, 5.05
	35 - 414	0.82, 0.88, 0.95, 1.01, 1.07, 1.14, 1.20, 1.26, 1.32, 1.39, 1.45, 1.51, 1.58, 1.64, 1.77, 1.89, 2.02, 2.15, 2.27, 2.40, 2.52, 2.65, 2.78, 2.90, 3.03, 3.15, 3.28, 3.41, 3.53, 3.66, 3.79, 3.91, 4.04, 4.16, 4.29, 4.42, 4.54, 4.79, 5.05, 5.30, 5.55, 5.80, 6.06, 6.31, 6.56, 6.81, 7.07, 7.32, 7.57

Model Order Designation

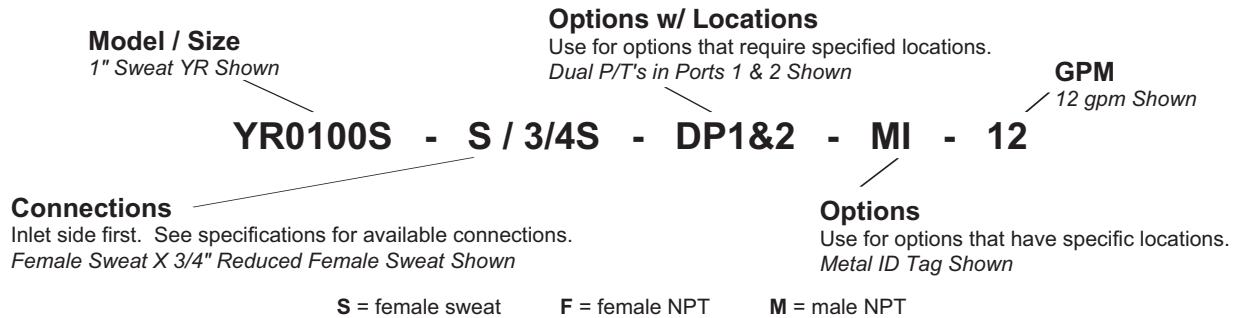

Options Available

- | | | |
|-----------------------------|--|--|
| AV Manual Air Vent | PI Plastic ID Tag | SN Standard Nipple |
| DN Dielectric Nipple | PT Pressure / Temperature Ports | XL Ext. P/T Port |
| HN Hose End Drain | PL Plug | <i>Various convenience fittings are available.</i> |
| MI Metal ID Tag | SE Stem Extender | |

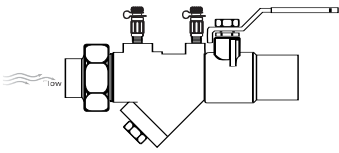

Model AC

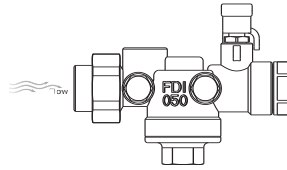

Model MC

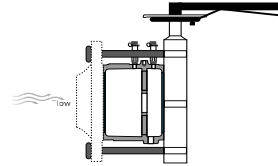

Model WB

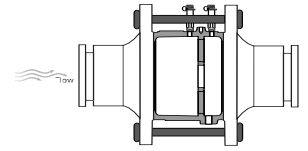

Model WG

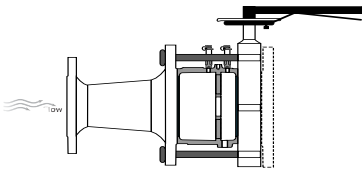

Model WR

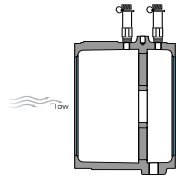

Model WS

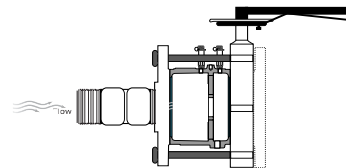

Model WT

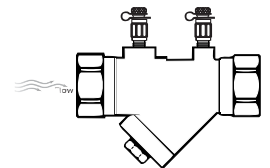

Model YR

Descriptions

- Model AC** 1/2" - 2"
- AutoFlow regulator • Ball valve
 - Port section • Union • Directional flow
 - Dual P/T ports • SWT or FPT (ball end) by SWT, FPT or MPT (union end)
 - One reduction size available on union end - 1/2" - 2" SWT, FPT or MPT

- Model MC** 1/2" - 3/4"
- AutoFlow regulator • Ball valve • Union
 - Four accessory port locations • Pressure / Temperature ports are standard

- Model WB** 2" - 8"
- Model WS or WU flow control valve with rods, nuts and Model BF butterfly valve.
 - 4" - 8" models have spacer flanges between valves • Shipped unassembled.
 - Does not include mating flange.

- Model WG** 2 1/2" - 14"
- AutoFlow regulator • Grooved Ends
 - Directional flow • Steel / Iron
 - Dual P/T ports

- Model WR** 3" - 6"
- AutoFlow regulator and butterfly valve with reduced inlet flange designed to mate with flanged ATC valve • Shipped assembled • Dual P/T ports • Directional flow

- Model WS** 2 1/2" - 30"
- AutoFlow regulator • Ductile iron wafer body (150# or 300#) • Directional flow
 - Dual P/T ports • Wafer style • Shipped with rods & nuts for use with customer-supplied companion flanges
 - 16" - 30" models have fabricated-steel wafer body for 150# ASA flanges

- Model WT** 2 1/2" - 4"
- AutoFlow regulator and butterfly valve with reduced threaded inlet designed to mate with threaded brass ATC
 - Dielectric fitting included • Directional flow
 - Dual P/T ports • Shipped assembled

- Model YR** 1/2" - 2 1/2"
- AutoFlow regulator • Port section
 - Directional flow • Dual P/T ports
 - Brass body • 1/2" - 1" SWT X SWT or FPT X FPT; 1 1/4" - 2 1/2" FPT X FPT SWT X SWT available for 1 1/4" - 2" with addition of brass sweat adapters

Model Designation Example:

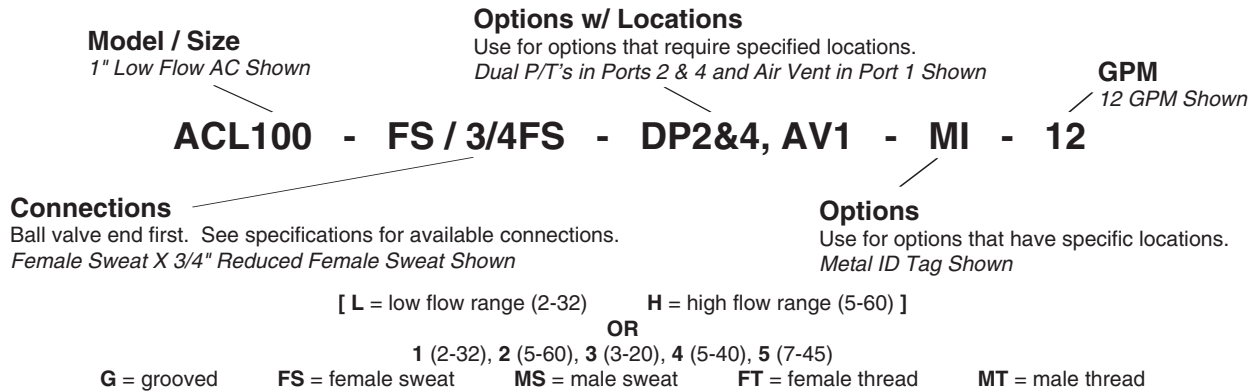

Options Available

AA Automatic Air Vent	EH Extended Handle with Memory Stop	PL Plug
AV Manual Air Vent	HN Hose End Drain Valve	SE Stem Extender
DX Dual XL P/T Ports (in lieu of std. ports)	PI Plastic Tag	T4 1/4" Accessory Port

Installation

- There are no minimum straight-piping requirements for the inlet or the outlet.
- Valves may be installed in horizontal or vertical lines. The vertical flow can be up or down.
- The flow arrow on the valve body must be pointing in the direction of flow.
- Avoid placing the valve close to a pump discharge. Allow 10' before the valve if possible.
- The model number gives the following information: body style, line size, end connections, P/T ports, GPM flow settings.

Flange and Groove Body Products

Most flange products are not furnished with flange gaskets or bolts, and unless specified otherwise have 150# raised-face flanges. Standard installation techniques covering flanged products should be followed. All products have a flow direction arrow. Care must be taken to locate the valve so that the arrow is pointed in the direction of the flow.

Grooved end products are to be installed using a "Victaulic-style coupling". The same installation techniques used to install standard "Victaulic" products should be followed. Care must be taken to assure the flow direction arrow is in the proper location.

AutoFlow Control Valves

Installation, Operation and Maintenance

Models AC, WB, WG, WR, WS, WT, YR

Installation *(continued)*

Wafer Body Valves (Model WB, WG, WR, WS, WT)

1. Make sure the long bolts and nuts to secure the wafer body are included with the valve.
2. Install the wafer body between 150# or 300# flanges making sure the flow arrow is in the direction of flow.
3. Make sure the inside diameter of the customer-supplied gaskets does not interfere with the flow.
4. The pressure or P/T ports should be vertical up. These ports can be used to vent air from each side of the body after filling and start-up.

Operation

General

Flow control valves are purchased for a specific GPM flow rate and are equipped with a spring-loaded piston to maintain that flow rate. Five spring ranges are available for AutoFlow valves. The first number is the differential pressure (psi) needed to achieve the GPM rating. The second number is the maximum D.P. where the rated GPM will be maintained. The model number will show the spring range of the product.

Example:

Model XX (-)

(-) can be L = 2-32, H = 5-60 or 1 (2-32), 2 (5-60), 3 (3-20), 4 (5-40), 5 (7-45)

Verifying Flow

The flow can be verified by measuring the DP (differential pressure) across the valve using the ports provided. If it measures between 2-32 (or other) the flow is usually in the specified flow range. Debris plugging one of the flow ports will cause the DP to read high, so make sure the unit is clean when verifying flow. There are several ways to measure DP:

- a. A pressure gauge with a P/T adapter can measure the pressure on each side of the valve. The differences between these readings is the DP.

- b. A differential pressure gauge can simultaneously measure from each port and read the DP directly.

Using a Strainer

A Y-strainer is recommended to prevent clogging. A 40-mesh screen is recommended for flows 1.5 GPM or less.

Accuracy

Accuracy is rated at 5% of the specified flow rate. Accuracy will vary with the temperature of the incoming fluid and specific gravity of the fluid. Rated flow rates are suitable for glycol solutions up to 50 percent.

Air Purge

AutoFlow valves will not work properly if air is trapped in the housing. Models with wafer bodies will always have a small amount of air because its body is higher than the top of the pipe. Air can cause a clicking noise in some valves.

Air can easily be vented using the pressure or PT ports. On small valves, 2" and under, the upstream port can be used. On larger steel valves, both ports should be purged because air can reside on both sides of the mid-plate. A simple way to purge air with PT ports is to use a 1/4" manual air vent (Model AV) with a long gauge adapter (Model GA30).

Maintenance

- There is no maintenance required on Flow Control valves.
- If inlet strainers are used they should be inspected and cleaned after start-up and every six months thereafter.
- The controlled flow rate can be changed in the field, on 1/2" - 2 1/2" AC, KY & YR Models, by replacing the cartridge assembly in the control valve. This requires

removing the cartridge from the controller. Specific instructions for making the change come with new cartridge assemblies. The change takes only 5 to 15 minutes with ordinary tools. Changing cartridges on larger valves should be done at the factory.

Call for an RMA number before returning equipment to the factory.

See next page for Troubleshooting information

Troubleshooting Guide

Possible Cause

Possible Solution

• PROBLEM: Low Water Flow

- | | |
|--------------------------------------|--|
| 1) Strainer clogged | 1) Back-flush or manually clean the coil strainer. |
| 2) Wrong location | 2) Make sure the valve is in the proper location with the correct GPM. |
| 3) Low system pressure | 3) If possible, check the pressure at the hook-up supply and return valves. The drop through the coil and ATC valve may be too large for the available head. |
| 4) Balance valve plugged | 4) The AutoFlow valve may have debris. Remove cartridge, clean and replace. |
| 5) ATC valve port closed or wrong Cv | 5) Make sure the ATC is wide open and has proper Cv. |
| 6) System valve is partially closed | 6) Open all manual system valves. |

• PROBLEM: High Water Flow

- | | |
|-----------------------------|---|
| 1) Wrong location | 1) Make sure the valve is in the proper location with the correct GPM. |
| 2) System pressure too high | 2) Check the differential pressure across the AutoFlow valve. If larger than 32 psi, close the return-side ball valve until the difference is less than 32 psi. The spring range on the cartridge could be changed to 5-60 psi which will also solve the problem. |
| 3) AutoFlow valve backward | 3) Check the flow arrow and reverse valve if necessary. |

• PROBLEM: Noise or Vibration

- | | |
|-------------------------------------|--|
| 1) AutoFlow valve clicking or noisy | a) Check the Delta P across the AutoFlow valve. If at or near the maximum, it may be necessary to replace the cartridge with a different spring range. |
| | b) Make sure the air is purged from the system. Air can cause a clicking noise. WS valves require air purging on each side of the mid-plate. |
| | c) Two AutoFlow valves close coupled in series can cause pulsing. |

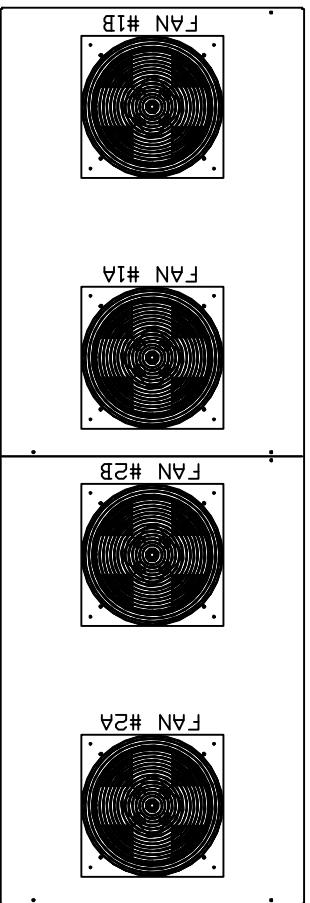

- INSTALLATION NOTES FOR SEISMIC:**
- 1) INSTALL (4) 1/4"-20 SELF TAPPING SHEET METAL SCREWS IN EACH REAR SERVICE DOOR.
 - 2) INSTALL 1/4"x1" NUTS, BOLTS AND WASHERS ON OUTER HOLES OF THE OUTSIDE FEET.
 - 3) USE 1/4"x1" NUTS, BOLTS AND WASHERS TO MOUNT BLOCKER PANELS.
 - 4) USE 5/16"x1" NUTS, BOLTS AND WASHERS TO MOUNT TANK TO BASEPLATE.
 - 5) RIVET SEISMIC DSP NUMBER TAG ABOVE DATA TAG.

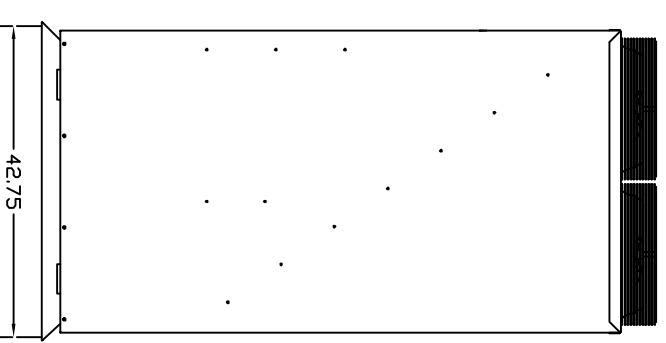
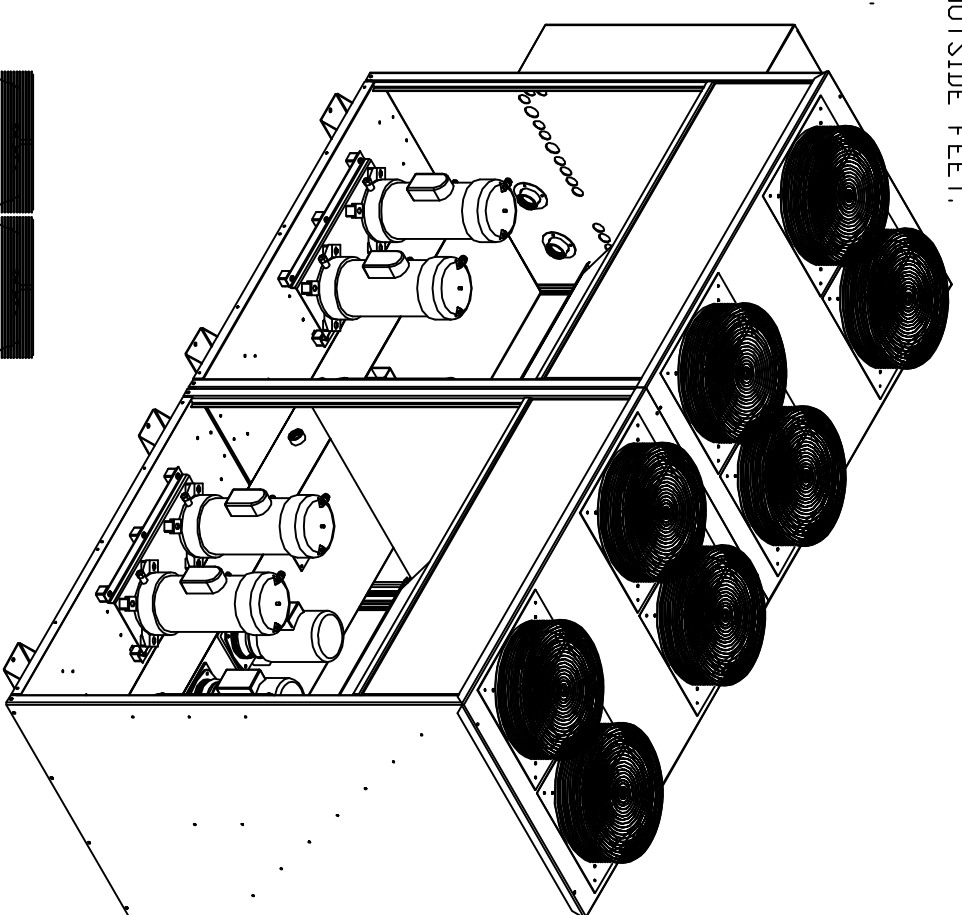
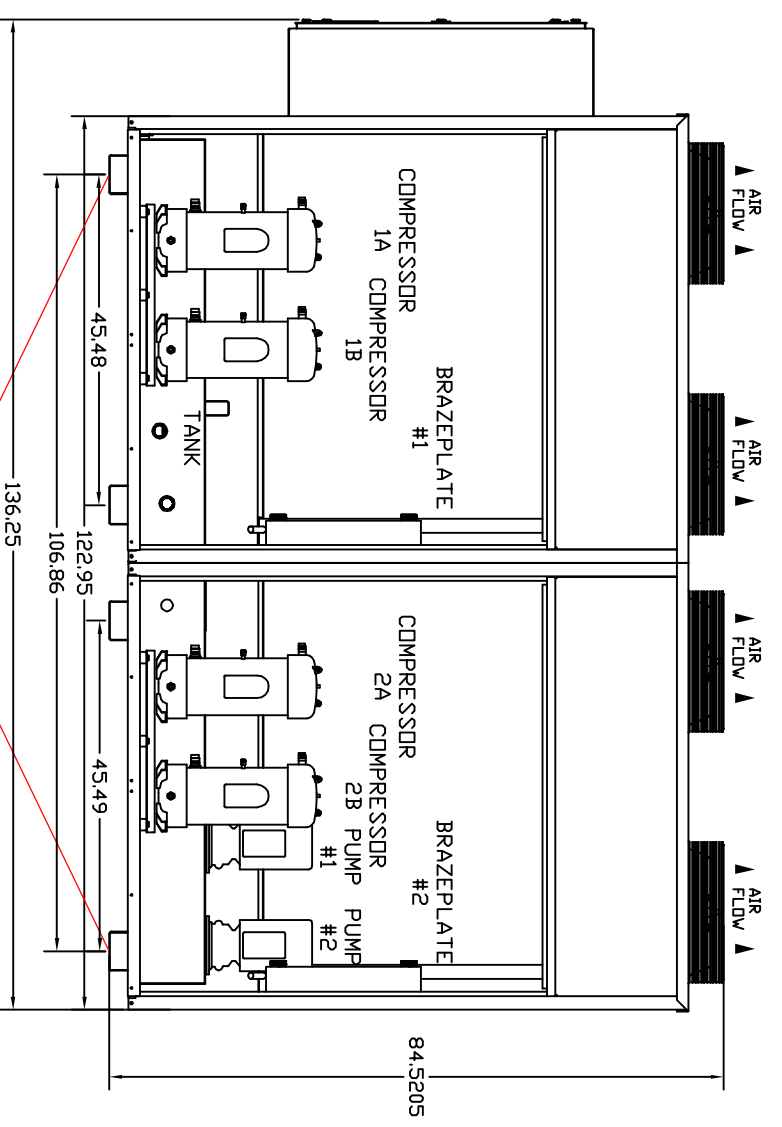
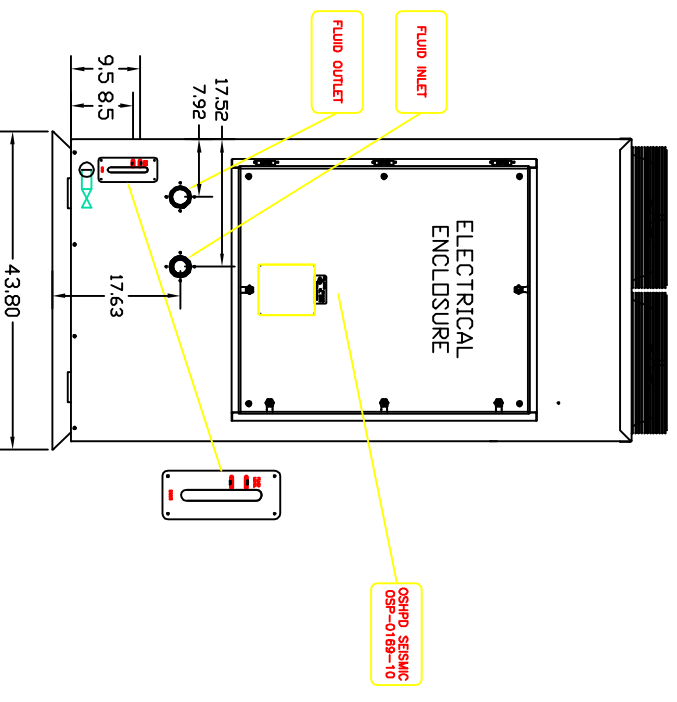
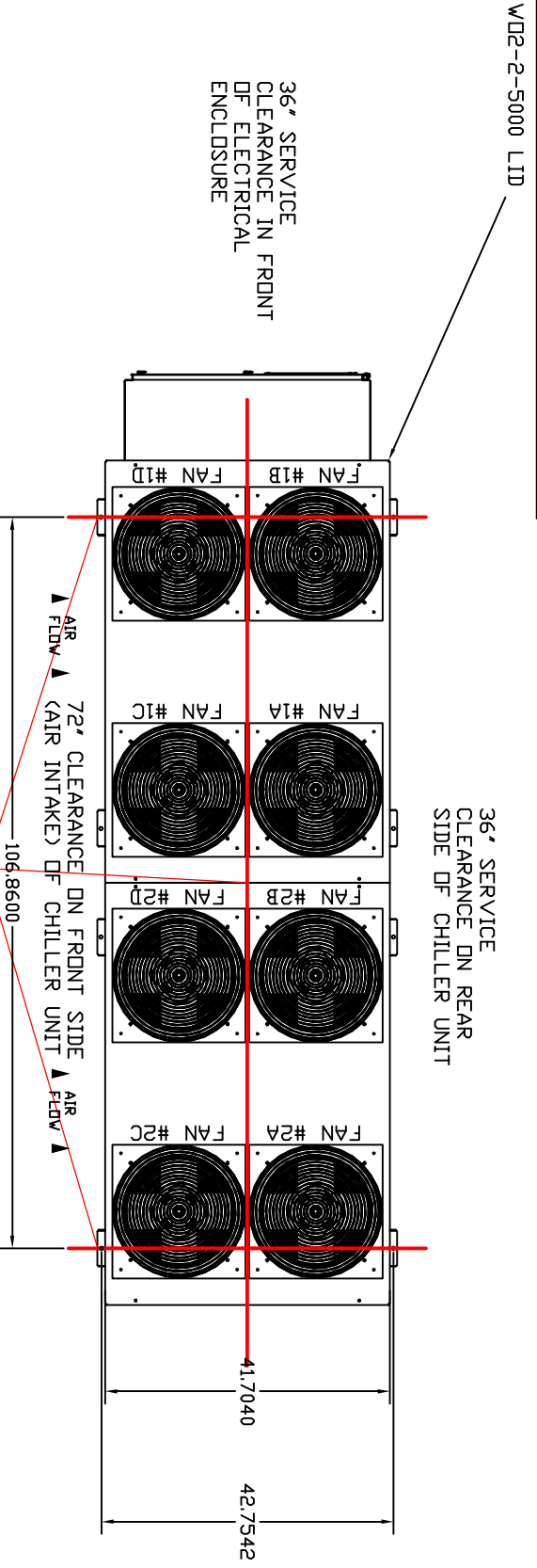

W02-2-7500 UNIT HAS (8) FANS
 W02-2-5000 UNIT HAS (4) FANS

LIFT MACHINE USING STRAPS THROUGH OUTSIDE FEET. BE SURE TO USE SPREADER BAR.

LIFT MACHINE USING STRAPS THROUGH OUTSIDE FEET. BE SURE TO USE SPREADER BAR.

ALL DIMENSIONS ARE IN INCHES

THIS PRINT CONTAINS INFORMATION PROPRIETARY TO KOOLANT COOLERS. MAY NOT BE DUPLICATED, REPRODUCED, OR SHARED IN ANY WAY WITHOUT THE EXPRESSED WRITTEN CONSENT OF KOOLANT COOLERS.

CONFIDENTIAL AND PROPRIETARY

DATE	DESCRIPTION OF REVISION	APPROVED BY

Thermal Solutions
 KALAMAZOO, MI
 PH (800) 968-5665
 WWW.DIMPLEXTHERMAL.COM

DESIGN BY: MAR
 DATE: 06/10/11
 DRAWN BY: MAR
 PAGE 1 OF 1
W02-5000/7500-2P (SEISMIC)
LAYOUT
 DRAWING NO. 450060

CHILLER INTERNAL

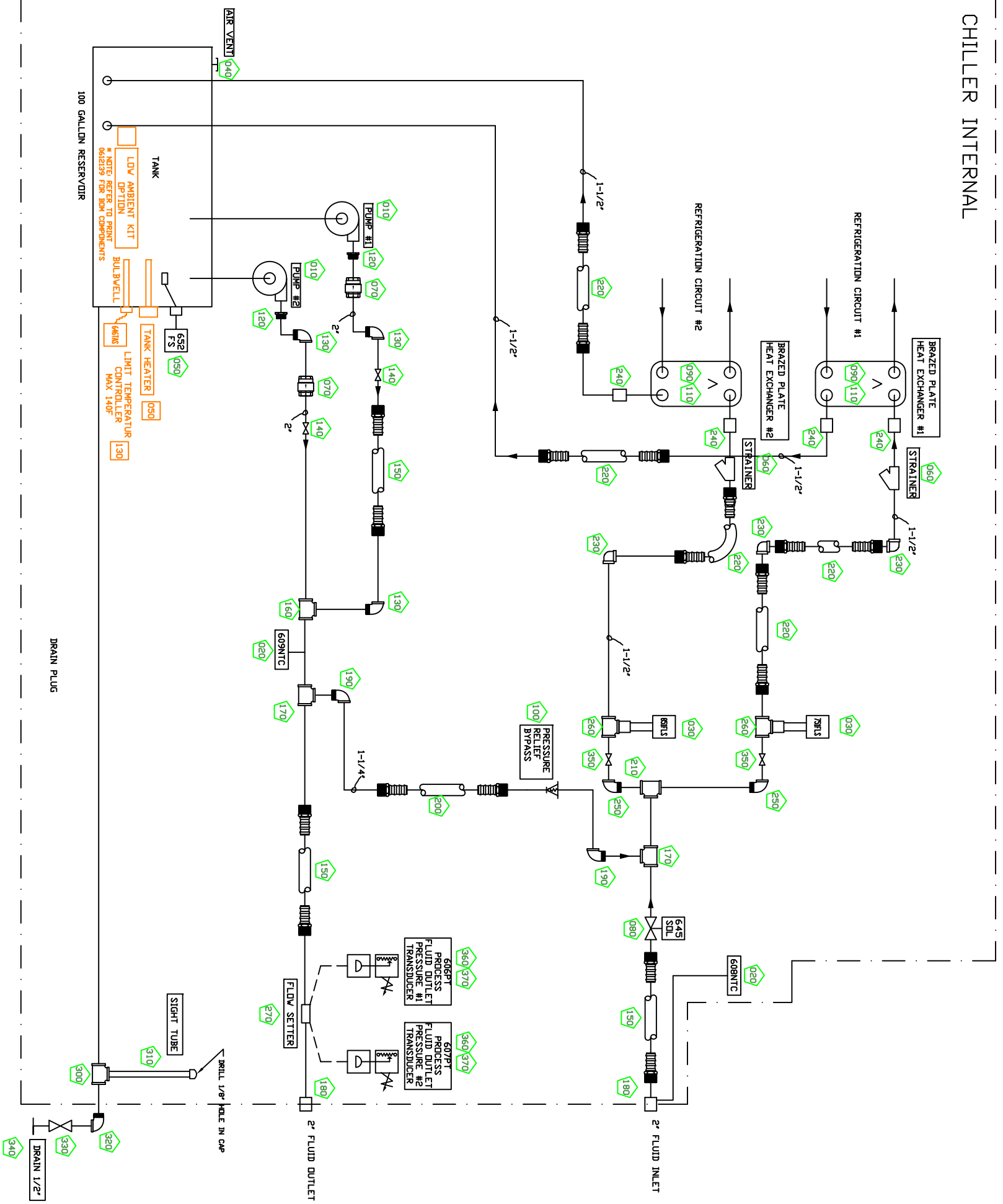

NOTE:
INSULATE TO ES-001
STANDARDS FOR LDW
TEMP APPLICATION,
PER 44°F SETPOINT,
FDR (-L) UNITS.

NOTE:
ALL INTERCONNECTING
PLUMBING TO BE RUN
IN NON-FERROUS MATERIAL,
OTHERWISE CONTACT
ENGINEERING. BDM
COMPONENTS EXCLUDED.

NOTE:
USE FOAM TAPE FOR PLUMBING
INSULATION. DO NOT USE CORK
TAPE.
ARMATLEX REQUIRED ON ANY
EXPOSED HOSE.

* PARTS NOT SHOWN ON DRAWING DETAIL

DATE	DESCRIPTION OF REVISION	APPROVED BY
05/04/10	ADDED DESCRIPTION FOR DRING	MAR <D>
03/16/10	UPDATED DESCRIPTION	MAR <D>
03/11/10	REMOVED WORD "CHILLER"	MAR <D>
02/22/10	RELABELED BALL VALVES	CJH <D>
02/17/10	CHANGED FLOAT SWITCH FROM 3896107	CJH <D>
02/16/10	ADDED PUMP RISER AND GASKETS	CJH <D>
02/16/10	UPDATED BUBBLING	CJH <D>
02/16/10	MOVED WHERE BYPASS TIES IN	CJH <D>
02/16/10	REMOVED BALL VALVES ON TANK RETURN	CJH <D>
02/16/10	ADDED FLOW SETTER	CJH <D>
02/16/10	MOVED 609N1C SENSOR TO COUPLING	CJH <D>

IND.	ID/DESCRIPTION	K.K. PART #	QTY	TYPE
001	HMBE-5000-2P-NF-L-M	0443570	2.0	PC
010	TPHK816-SS PUMP VERTICAL STAINLESS (3 HP) 230/460/3/60 12.6/6.3A 1 EFC MOTOR, ALL WETTED PARTS STAINLE SS STEEL, TC/TC VITON SEALS, NPT DI SCHARGE, VALVUS	1785007	2.0	PC
* 010	1/2" SENSOR ASSEMBLY FOR CARREL MPO617671 10K THERMISTOR 10" CARREL PLATTINUM, 2 WIRE CONSTRUCTION WITH DRAIN WIRE ATTACHED TO SHEATH, 3/16 DIA SHEATH, 316 SST 5-1/2" OVERALL LENGTH, 4-1/2" HOT LEG WITH 90° BEND PVC LEAD-WIRE (300 VAC RATED) WITH SHIELD AND DRAIN, 10 FT LONG GREY WIRE COVER, NUC COL D END TERMINATION GENERALLY USED ON 15 TON UNITS AND BELOW WITH 4 POINT CRIMP CLASS A SENSOR/TC	0611318 4801215	2.0 1.0	ASSEM PC
* 020	CUMPRESSION FITTING 1/2" NPT X 3/16 TUBE, BRASS	7504920	1.0	PC
030	F51M-1C SWITCH FLOW	3653015	2.0	PC
040	NEMA 3R ENCLOSURE JOHNSON CONTROLS	4100003	1.0	PC
050	PMB-05-10 AIR VENT 3/8" FENNER L-21N-11A-1-B FLOAT SWITCH	3896113	1.0	PC
060	HARVIL	4353014	2.0	PC
070	777SI-1 1/2" Y-STRAINER FILT BRONZE WATTS	4153201	2.0	PC
080	600 VALVE CHECK FLUID 2 BRONZE WATTS	4804217	1.0	PC
090	8210G100 VALVE SOLENOID 2" 24VAC CV=43 DRIFTC 1-3/4" 5 PSI MIN. PR ESSURE DIFFERENTIAL 125 PSI MAX WIT H WATER 90 PSI MAX WITH LIGHT OIL W ITH 24VAC/60HZ COIL NORMALLY CLOSE D WITH RED HAT II NEMA 4X ENCLOSURE ASSD	2200512	2.0	PC
100	K205303C BRAZED PLATE H/E 12 TON A1/1/2" 1-1/8" SOLDER J B1/1/2" 1-1/ 2" NPT X 1-1/4" MPT X 1-1/4" MPT 3/17/10: NEW VENDOR PART NUMBER 69 D1DX35-10U) SEAT/O-RING CHANGED DN CMP	4189076	1.0	PC
* 110	0441282	0441282	2.0	ASSEM
* 010	BP INSULATION FOR K205 FRONT	0441282-1	1.0	PC
* 020	BP INSULATION FOR 2200512 MIDDLE	0441282-2	1.0	PC
* 030	BP INSULATION FOR K205 BACK	0441282-3	1.0	PC
120	BUSHING 2" MPT X 1-1/4" FPT BRASS	7516603	2.0	PC
130	ELBOW 90° 2" MPT X FPT BRASS	7516303	3.0	PC
140	VALVE BALL BRONZE 2" WATTS	4113200	2.0	PC
150	2" HOSE ASSY NON-FERROUS	0606866	3.0	ASSEM
* 001	HOSEBAR 2" MPT X 2" HOSE BRSS	7516901	2.0	PC
* 002	60250 2" HOSE CLAMP 1-3/4" 2-5/8" SS TYPE	7797412	2.0	PC
* 003	HOSE 2" DRAC 200 PSI RED HOSE -20 ID 190 089 F GOODYEAR	4410005	3.0	PC
160	TEE 2" X 2" X 2" FPT BRASS	7516100	1.0	PC
170	TEE 2" X 2" X 1-1/4" FPT BRSS	7516104	2.0	PC
180	COUPLING 2" FPT X 2" FPT SS FULL 304	7216201	2.0	PC
190	ELBOW 90° 1-1/4" MPT X 1-1/4" FPT BRSS	7510301	2.0	PC
200	1 1/4" HOSE ASSY NON-FERROUS	0607711	1.0	ASSEM
001	HOSEBAR 1-1/4" MPT X 1-1/4" HOSE BRSS	7510910	2.0	PC
002	HOSE 1-1/4" RED WINGFOOT 250 PSI GOODYEAR # 569-025-318	7797409	3.0	PC
210	TEE 1-1/2" X 1-1/2" X 2" FPT BRSS	7512104	1.0	PC
220	1 1/2" HOSE ASSY NON-FERROUS	0607036	5.0	ASSEM
* 001	HOSEBAR 1-1/2" MPT X 1-1/2" HOSE BRSS	7512901	2.0	PC
* 002	60200 HOSE CLAMP 1-1/4" - 2-1/8" TYPE	7797411	2.0	PC
003	HOSE 1-1/2" RED WINGFOOT 250 PSI ELBOW 90° 1-1/2" FPT X 1-1/2" FPT BRSS	4410004	3.0	PC
230	COUPLING 1-1/2" X 1-1/2" FAT 304 SS	7512301	3.0	PC
240	MACHINED COUPLING CAN NOT USE CAST ELBOW 90° 1-1/2" MPT X FPT BRSS	7216201	4.0	PC
250	TEE 1-1/2" X 1-1/2" X 1" FPT BRSS	7512300	2.0	PC
260	YR0200-F1/1 36 GPM FLOW SETTER	7512102	2.0	PC
270	2" FEMALE THREADED BODY 1S BRASS	4100076	1.0	PC
* 280	9800902	9800902	4.0	PC
* 290	0443831	0443831	2.0	ASSEM
* 010	POLYPROPYLENE 1/2" X 4" X 8	7899013	0.1	PC
300	TEE 1" X 1" X 1/2" FPT BRSS	7508103	1.0	PC
310	KK 1" SIGHT GLASS NON-FERROUS	7400004	1.0	ASSEM
010	PIPE 1" PVC CLEAR	7408800	1.1	PC
* 020	TEE 1" FPT X 1" FPT X 1" FPT BRSS	7508105	1.0	PC
* 030	ADAPTER 1" MPT X 1" SLIP MALE PVC40	7408701	1.0	PC
* 040	NIPPLE 1" MPT X 3 BRSS	7508003	1.0	PC
* 050	CAP 1" PVC40	7408900	1.0	PC
* 060	ELBOW 90° 1/2" MPT X 1/2" FPT BRASS	7504302	1.0	PC
320	SHEET	4123051	1.0	PC
330	BP-1 VALVE BOILER DRAIN 1/2" NPTM X GHTM WATTS	4123051	1.0	PC
340	CAP 3/4" NATIONAL HOSE BRASS	7506504	1.0	PC
350	VALVE BALL BRONZE 1-1/2" WATTS	4113150	2.0	PC
360	PRESSURE TRANSDUCER CARREL SPK10013R0	4807736	2.0	PC
370	SPK001-5310 CORD SET CARREL 14-1/2" 370	4807715	2.0	PC

3CDimplex
Thermal Solutions

DESIGN BY: MAR
DRAWN BY: MAR
DATE: 01/08/09
PAGE 1 OF 1

KALAMAZOO, MI
PH (800) 968-5665
WWW.DIMPLEXTHERMAL.COM

W02-2-5000-2P-L-M
PLUMBING

DRAWING NO.
443570

ALL DIMENSIONS ARE IN INCHES

THIS PRINT CONTAINS INFORMATION PROPRIETARY TO DIMPLEX THERMAL SOLUTIONS. MAY NOT BE DUPLICATED, REPRODUCED, OR SHARED IN ANY WAY WITHOUT THE EXPRESSED WRITTEN CONSENT OF DIMPLEX THERMAL SOLUTIONS.

CONFIDENTIAL AND PROPRIETARY

CHILLER INTERNAL

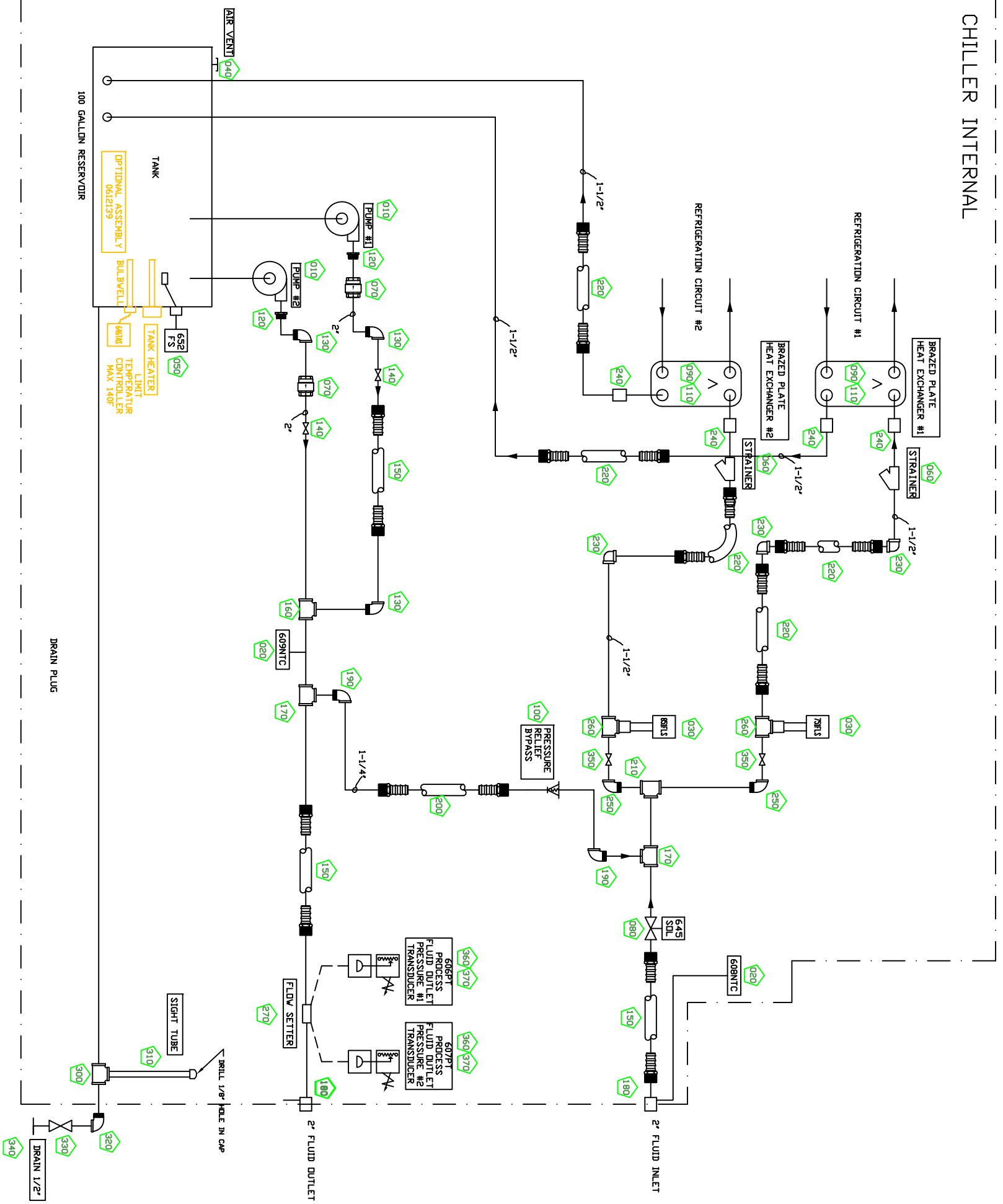

NOTE:
INSULATE TO ES-001
STANDARDS FOR LDW
TEMP APPLICATION,
PER 44F SETPOINT,
FDR (-L) UNITS.

NOTE:
ALL INTERCONNECTING
PLUMBING TO BE RUN
IN NON-FERROUS MATERIAL,
OTHERWISE CONTACT
ENGINEERING. BOM
COMPONENTS EXCLUDED.

**USE FOAM TAPE FOR PLUMBING
INSULATION. DO NOT USE CORK
TAPE.**
**ARMATLEX REQUIRED ON ANY
EXPOSED HOSE.**

ALL DIMENSIONS ARE IN INCHES
THIS PRINT CONTAINS INFORMATION PROPRIETARY
TO DIMPLEX THERMAL SOLUTIONS. MAY NOT BE
DUPLICATED, REPRODUCED, OR SHARED IN ANY WAY
WITHOUT THE EXPRESSED WRITTEN CONSENT OF
DIMPLEX THERMAL SOLUTIONS.
CONFIDENTIAL AND PROPRIETARY

* PARTS NOT SHOWN ON
DRAWING DETAIL

DATE	DESCRIPTION OF REVISION	APPROVED BY
05/04/10	DESCRIPTION UPDATED FOR DRWG	MAR <D>
03/16/10	UPDATED DESCRIPTION	MAR <D>
03/11/10	REMOVE WORD "CHILLER"	MAR <D>
02/22/10	RELABELED BALL VALVES	CJH <D>
02/17/10	CHANGED FLOAT SWITCH FROM 3896107	CJH <D>
02/16/10	ADDED PUMP RISER AND GASKETS	CJH <D>
02/16/10	UPDATED BUBBLING	CJH <D>
02/16/10	MOVED WHERE BYPASS TIES IN	CJH <D>
02/16/10	REMOVED BALL VALVES ON TANK RETURN	CJH <D>
02/16/10	ADDED FLOW SETTER	CJH <D>
02/16/10	MOVED 609N1C SENSOR TO COUPLING	CJH <D>

IND.	1D/DESCRIPTION	K.K. PART #	QTY	TYPE
001	MANIFOLD 2" NPT	0443468	2.0	PC
010	1/2" SENSOR ASSEMBLY FOR CARTEL	1785007	2.0	PC
020	1/2" SENSOR ASSEMBLY FOR CARTEL	0611318	2.0	ASSEM
030	1/2" SENSOR ASSEMBLY FOR CARTEL	4801215	1.0	PC
040	1/2" SENSOR ASSEMBLY FOR CARTEL	0611318	2.0	ASSEM
050	1/2" SENSOR ASSEMBLY FOR CARTEL	4801215	1.0	PC
060	1/2" SENSOR ASSEMBLY FOR CARTEL	0611318	2.0	ASSEM
070	1/2" SENSOR ASSEMBLY FOR CARTEL	4801215	1.0	PC
080	1/2" SENSOR ASSEMBLY FOR CARTEL	0611318	2.0	ASSEM
090	1/2" SENSOR ASSEMBLY FOR CARTEL	4801215	1.0	PC
100	1/2" SENSOR ASSEMBLY FOR CARTEL	0611318	2.0	ASSEM
110	1/2" SENSOR ASSEMBLY FOR CARTEL	4801215	1.0	PC
120	1/2" SENSOR ASSEMBLY FOR CARTEL	0611318	2.0	ASSEM
130	1/2" SENSOR ASSEMBLY FOR CARTEL	4801215	1.0	PC
140	1/2" SENSOR ASSEMBLY FOR CARTEL	0611318	2.0	ASSEM
150	1/2" SENSOR ASSEMBLY FOR CARTEL	4801215	1.0	PC
160	1/2" SENSOR ASSEMBLY FOR CARTEL	0611318	2.0	ASSEM
170	1/2" SENSOR ASSEMBLY FOR CARTEL	4801215	1.0	PC
180	1/2" SENSOR ASSEMBLY FOR CARTEL	0611318	2.0	ASSEM
190	1/2" SENSOR ASSEMBLY FOR CARTEL	4801215	1.0	PC
200	1/2" SENSOR ASSEMBLY FOR CARTEL	0611318	2.0	ASSEM
210	1/2" SENSOR ASSEMBLY FOR CARTEL	4801215	1.0	PC
220	1/2" SENSOR ASSEMBLY FOR CARTEL	0611318	2.0	ASSEM
230	1/2" SENSOR ASSEMBLY FOR CARTEL	4801215	1.0	PC
240	1/2" SENSOR ASSEMBLY FOR CARTEL	0611318	2.0	ASSEM
250	1/2" SENSOR ASSEMBLY FOR CARTEL	4801215	1.0	PC
260	1/2" SENSOR ASSEMBLY FOR CARTEL	0611318	2.0	ASSEM
270	1/2" SENSOR ASSEMBLY FOR CARTEL	4801215	1.0	PC
280	1/2" SENSOR ASSEMBLY FOR CARTEL	0611318	2.0	ASSEM
290	1/2" SENSOR ASSEMBLY FOR CARTEL	4801215	1.0	PC
300	1/2" SENSOR ASSEMBLY FOR CARTEL	0611318	2.0	ASSEM
310	1/2" SENSOR ASSEMBLY FOR CARTEL	4801215	1.0	PC
320	1/2" SENSOR ASSEMBLY FOR CARTEL	0611318	2.0	ASSEM
330	1/2" SENSOR ASSEMBLY FOR CARTEL	4801215	1.0	PC
340	1/2" SENSOR ASSEMBLY FOR CARTEL	0611318	2.0	ASSEM
350	1/2" SENSOR ASSEMBLY FOR CARTEL	4801215	1.0	PC
360	1/2" SENSOR ASSEMBLY FOR CARTEL	0611318	2.0	ASSEM
370	1/2" SENSOR ASSEMBLY FOR CARTEL	4801215	1.0	PC

3CDimplex
Thermal Solutions

DESIGN BY: MAR
DRAWN BY: MAR
DATE: 01/08/09
PAGE: 1 OF 1

KALAMAZOO, MI
PH (800) 968-5665
WWW.DIMPLEXTHERMAL.COM

**SCHNEIDER
ELECTRIC**

PLUMBING
DRAWING NO. 443468

COMPRESSOR	HIGH PRESSURE SWITCH	DISCHARGE TRANSDUCER	DISCHARGE TEMPERATURE	LIQUID LINE TEMPERATURE	LDV PRESSURE SWITCH	SUCTION TRANSDUCER	SUCTION TEMPERATURE	LIQUID LINE SOLENOID
1A & 1B	715PS	710PT	708NTC	753NTC	710PT	711PT	709NTC	738SOL
2A & 2B	815PS	810PT	808NTC	853NTC	810PT	811PT	809NTC	838SOL
3A & 3B	915PS	910PT	908NTC	953NTC	910PT	911PT	909NTC	938SOL
4A & 4B	1015PS	1010PT	1008NTC	1053NTC	1010PT	1011PT	1009NTC	1038SOL

COMPONENT IDENTIFICATION

THIS PRINT CONTAINS INFORMATION PROPRIETARY TO DIMPLEX THERMAL SOLUTIONS. MAY NOT BE DUPLICATED, REPRODUCED, OR SHARED IN ANY WAY WITHOUT THE EXPRESSED WRITTEN CONSENT OF DIMPLEX THERMAL SOLUTIONS.

CONFIDENTIAL AND PROPRIETARY

DATE	DESCRIPTION OF REVISION	APPROVED BY
05/06/10	ADDED PRE-BENT LINES	MAR <D>
03/16/10	UPDATED DESCRIPTION	MAR <D>
03/08/10	CHANGE REFRIG LBS FROM 25	MAR <D>
02/15/10	CHANGED COIL ASSEMBLY TO 24V	CJH <D>

DESIGN BY: MAR
DATE: 1/14/10

DRAWN BY: CJH
PAGE: 1 OF 1

W0()-2-5,000-(2)P-M

REFRIGERATION

Thermal Solutions

KALAMAZOO, MI
PH: (800) 968-5665
WWW.DIMPLEXTHERMAL.COM

SCHNEIDER ELECTRIC
DRAWING NO: 443569

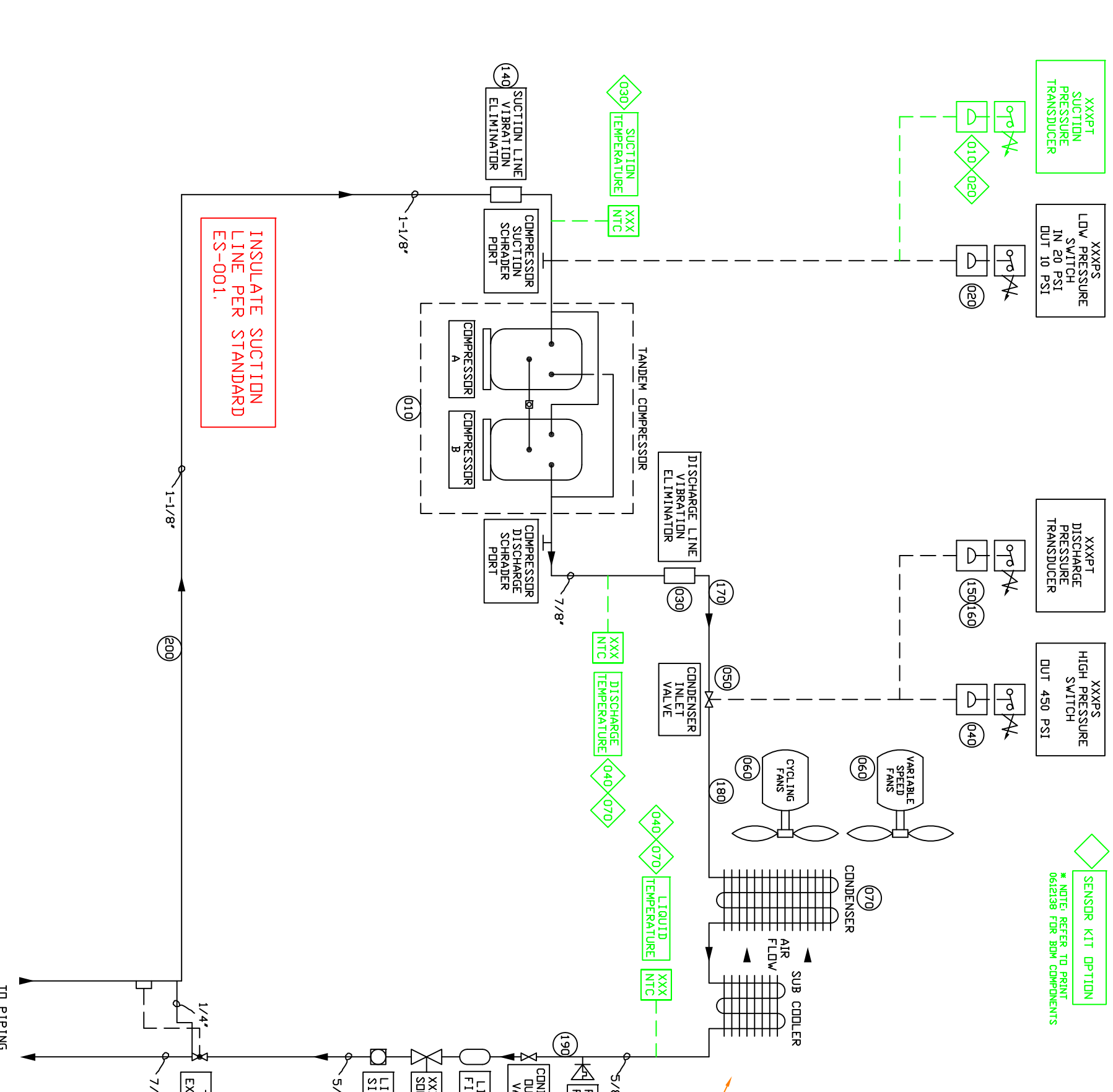

NO.	ID/DESCRIPTION	K, K, PART #	QTY	TYPE
120	SAFETY SIGHT GLASS 5/8 DDF	2720004	1.0	PC
130	SPRANL ANTI-C VALVE EXPANSION	2760105	1.0	PC
140	VAR-9 VIBRATION ELIMINATOR 1-1/8	2980009	1.0	PC
150	PRESSURE TRANSDUCER CARTEL SPK1003380	4807739	1.0	PC
160	SPK00-5310 GORD SET CARTEL 14-1/2" WORKS WITH VDC AND PA TRANSDUCCERS. ALSO FITS JOHNSON CONTROLS WHITE SIGNAL GREEN/GRND/OVDC. BLACK = +VDC (NEUT POWER) CARTEL	4807715	1.0	PC
170	SERV VALVE TO COIL, 0443763	7399215	1.0	PC
180	LIQUID LINE, 444333	7399212	1.0	PC
200	SUCT VIB ELIM TO HP, 0443765	7399213	1.0	PC
210	TUBING 1/4 SUCT COPPER REFERIG	7302000	2.0	PC
220	TUBING 5/8 HARD COPPER ACR	7305010	5.0	PC
230	TUBING 7/8 HARD COPPER ACR	7309010	6.0	PC
240	TUBING 1-1/8 HARD COPPER ACR	7309010	6.0	PC
250	REFRIGERANT R407C IN A 115LB CYL	2990030	22.5	PC

NO.	ID/DESCRIPTION	K, K, PART #	QTY	TYPE
001	ASSEM			
010	10T (2) 460/3/60 PKG	0612141	1.0	ASSEM
010	COMPRESSOR 5 TON 460/3/60 R-407C	0612002	2.0	ASSEM
010	C-S48453H6G COM 5 460/3/60 407C	1450064	1.0	PC
020	COMPRESSOR CODE #809 966 888 USED WITH R407C. HAS PVE OIL SANVYD	1298032	1.0	PC
020	FLTS ZR18-81 480 VAC, 70 WATTS 48 LEADS. COIL AND (11/06/09) OLD PART NUMBER 018-0072-05	2720003	1.0	PC
020	SA-14S SIGHT GLASS 1/2 DDF	3807156	8.0	PC
030	SPRANL 3/4 RIGID CONDUIT	3802015	8.0	PC
040	PIVOT-LOCK-D TERMINAL RING INSULATED	7720250	14.0	PC
050	500/PKG FAN/UNIT	7725111	14.0	PC
050	WASHER 5/16-18 X 2-1/2 HEX HEAD CAP	7725111	2.0	PC
060	NUT 5/16-18 HEX NYLON INSERT LOCK	7714013	8.0	PC
080	DISCHARGE COMP 1A, 0443871	7399219	1.0	PC
090	DISCHARGE COMP 1B, 0443872	7399220	1.0	PC
100	W-4047 TEE 5/8 X 5/8 X 7/8 C	7305402	2.0	PC
110	W-10145 COUPLING 5/8 X 7/8 C	7305190	1.0	PC
130	W-4031 TEE 7/8 C X C X C	7307390	1.0	PC
140	SUCTION COMP 1A, 0443954	7399221	1.0	PC
150	SUCTION COMP 1B, 0443955	7399222	1.0	PC
020	SWITCH 10/20 CUT IN 20 PSI. CUT OUT 10/20 PSI. CAN BE USED AS LP FOR 134 A. FORMERLY 10/22 SWITCH. JOHNSON. SOURCE DISTRIBUTION YK-03L 0110-010	3640006	1.0	PC
030	VIBRATION ELIMINATOR 7/8	2980008	1.0	PC
040	SWITCH HIGH PRESSURE 450 MANUAL VENDOR PART NUMBER: YK-03H 0110-45 OR 350Z(MR) ENCAPSULATED WITH A 9 FID OT CORD. OPENS HIGH, MANUAL RESET, OPENS 450 PSI, 407C/404A HP SWITCH. RESOURCE DISTRIBUTION	3640017	1.0	PC
050	VALVE ANGLE REFERIG 7/8	3980003	1.0	PC
060	FAN ASSEMBLY 18"-5/8 1PH OUTDOOR 1 PHASE WEATHER PROOF MOTOR WITH 5/8 KEYS SHAFT V-SPEED APPLICATION. 0484170E1H MOTOR 1/2 HP 1PH 5/8 KEY ED SHAFT. SEALED IN SHAFT 48 FRAM PLE MODEL #SVA48A170E1BPA CAT # 13329A 1.60 HZ 1/2 HP 1625 RPM 230/460/115 0-230/380/1 MARATHON (6/7/08 DLD # 04 8A170E1B CHANGE REV LEVEL)	0608586	2.0	ASSEM
010	61142601 FAN BLADE 18 INCH 5/8 KEY ED HUB 28 DEG CV F08Y18-1828 5/8 DN 1/2" hub use adapter 4500052	4051311	1.0	PC
020	1/2" hub use adapter 4500052	4500035	1.0	PC
030	FAN GUARD MOUNT 18 DVG #101515	4507018	1.0	PC
040	FAN GUARD FULL 18 DVG #101515	4507019	1.0	PC
050	VENTURI 18 GALVANIZED DVG #201678	4504182	1.0	PC
060	CAP 5/8 DIA X 1-1/2 VINYL	4021315	1.0	PC
070	VIBRA-TITE 1 OZ. BOTTLES	9803000	0.1	PC
080	SILICONE SEALANT CLEAR	4508976	0.1	PC
090	CS-A 31007 ANTI-SEIZE	4021324	0.1	PC
100	BL50 LOCKNUT 1/2 TIGER GRIP STEEL	3800060	2.0	PC
110	CG-5050S CORD STRAIN RELIEF	3800471	2.0	PC
120	WIRE 14/3 SDV/SDV 600V BLACK	3807095	5.0	PC
070	COIL 20 TON 'REMOTE' HEADER	1413072	1.0	PC
080	VALVE ANGLE REFERIG 5/8	3980002	1.0	PC
090	C-1165S FILTER DRIER 5/8"	2730006	1.0	PC
100	SPRANL ANTI-C VALVE EXPANSION 5/8"	2710006	1.0	PC
110	E10350 VALVE SOLENOID 5/8"	0608319	1.0	ASSEM
010	ROQUERS MKC-2E COIL SPRANL MKC-2E 24VAC 30-60 HZ COIL ASSEMBLY MKC-2E SOLENOID COIL 24V AC 30/60HZ ASSEMBLY WITH CABLE IS 0608319 SPD RLAN	2710113	1.0	PC
020	1220S CONNECTOR: DIN 43650 18MM W/ 5 METER GRAY PVC CABLE AC/DC 0-230 V 18 GA WIRE. UL RECOGNIZED E172930 MURRELEKTRONIK NEW PART NUMBER 7000-18081-2160500	4807100	1.0	PC

INSULATE SUCTION LINE PER STANDARD ES-001.

INSTALL HEAT TAPE ON CONDENSER HEADER BEFORE INSTALLING IN UNIT. RUN THE HEAT TAPE AROUND HEADER AND ATTACH WITH HOSE CLAMPS. USE 10FT. OF HEAT TAPE PER CONDENSER. HEATER TO BE INSULATED WITH 1/2" OF ARMAFLEX AFTER HEAT TAPE IS INSTALLED.

LOW AMBIENT KIT OPTION

NOTE: REFER TO PRINT 0612139 FOR BDM COMPONENTS

ALL DIMENSIONS ARE IN INCHES

TO PIPING

PARTS NOT SHOWN ON DRAWING DETAIL

XXXXT
SUCTION
PRESSURE
TRANSDUCER

XXXXS
LOW PRESSURE
SWITCH
IN 20 PSI
DUT 10 PSI

XXXXPT
DISCHARGE
PRESSURE
TRANSDUCER

XXXXS
HIGH PRESSURE
SWITCH
DUT 450 PSI

SENSOR KIT OPTION!
* NOTE REFER TO PRINT
0612139 FOR BOM COMPONENTS

NO.	ID/DESCRIPTION	K.K.PART#	QTY	TYPE
140	VAR-9 VIBRATION ELIMINATOR 1-1/8	2980009	1.0	PC
150	VAR-9 VIBRATION ELIMINATOR 1-1/8 X 13 (UL P-9) PACKLESS PRESSURE TRANSDUCER CARTEL SPK10033RD	4807739	1.0	PC
160	SPKCOD-5310 GORD SET CARTEL 14-1/2" WPKS WITH VDC AND MA TRANSDUCERS, ALSO FITS JOHNSON CONTROLS (WHITE = SIGNAL, GREEN=GROUND/OVDC, BLACK = TUBING 1/4 SPT COPPER REFRLG. TUBING 7/8 HARD COPPER AGR TUBING 1-3/8 HARD COPPER AGR REFRIGERANT R407C IN A 115LB CYL	4807715	1.0	PC
170	7302000	2.0	PC	
180	7307010	5.0	PC	
190	7309010	5.0	PC	
200	7311010	6.0	PC	
210	2990030	30.0	PC	

NO.	ID/DESCRIPTION	K.K.PART#	QTY	TYPE
001	WIR-2-7500-6M REFR 460V	0443467	1.0	ASSEM
010	GE 1ST 460/3/60 PKR	0612153	1.0	ASSEM
010	COMPRESSOR 7.5 TON 460/3/60 R-407C C-SCN6036RK CDM 7.5 460/3/60 407C 440/460 INCLUDE MOUNTING KIT!	1450077	2.0	ASSEM
020	COMPRESSOR CODE #809 183 88. USED WITH R407C. HAS PVC OIL SNAVER 018-0095-05 CRANKCASE HEATER LEADS ZR18-81 480 VAC. 70 VAITS 48 T-NUMBER 018-0072-052	1298032	1.0	PC
020	SA-145 SIGHT GLASS 1/2 DDF	2720003	1.0	PC
030	SPORLAN 3/4 RIGID CONDUIT	3807156	8.0	PC
040	PV10-10R-D TERMINAL RING INSULATED 500/2/K PANDUIT	3802015	8.0	PC
050	SUREL 5/16-18 X 2-1/2 HEX HEAD CAP WASHER 3/16 LOCK	7720250	14.0	PC
060	WASHER 3/16 FLAT	7725222	24.0	PC
070	NUT 5/16-18 HEX NYLON INSERT LOCK	7714013	8.0	PC
080	NUT 5/16-18 *J* CABENUT	7714022	6.0	PC
020	LOW PRESSURE SWITCH 10/20	36440006	1.0	PC
030	VAR-8 VIBRATION ELIMINATOR 7/8	2980008	1.0	PC
040	7/8 X 11-1/2 CUL P-8) PACKLESS SWITCH HIGH PRESSURE 450 MANUAL VENDOR PART NUMBER: YK-03H 0110-45 0830Z(MR) ENCASULATED WITH A 9 FET DI-CORD OPENS HIGH MANUAL RESET. DEPS 480 PSI. 407C/404A HP SWITCH. RESOURCE DISTRIBUTION 7/8	3640017	1.0	PC
050	VALVE ANGLE RETRIG 7/8	3980003	1.0	PC
060	FAN ASSEMBLY 16"-5/8 1PH OUTDOOR 1 PHASE WEATHER PROOF MOTOR WITH 5/8 KEYPAD SHAFT V-SPEED APPLICATION 1.2 FLA@460V	0608585	4.0	ASSEM
010	048A170E1H MOTOR 1/2 HP 1PH 5/8 KEY ED SHAFT SEALED DN SHAFT 48 FRAM E END. TFC. 60 DEG C. 1625 RPM SAM PLE MODEL #SV498A170E1A CAT # 1339A 1.60 HZ. 1/2 HP 1625 RPM 230/460/211 2.4A/1.2A 50 HZ. 1/3 HP 1425 RPM 19 0-230/380/1 MARATHON (6/08 DLD # 04 8A170E1B CHANGE REV LEVEL) 61146601 FAN BLADE 16 INCH 5/8 KEY ED HUB CH F V 5/8 30 DEG D N DISCHARGE 3/16 KEYPAD LAU FOR 1/2" DIA USE 4600052	4051311	1.0	PC
030	FAN GUARD MOUNT 16 DNG #101513	4507016	1.0	PC
040	FAN GUARD FULL 16 DNG #101514	4507017	1.0	PC
050	VENTURI 16 GALVANIZED DWG #201676 18 GA MEMPHIS METAL	4504162	1.0	PC
060	VIBRA-TITE 1 OZ. BOTTLES	9803000	0.1	PC
070	CAP 5/8 DIA X 1-1/2 VINYL	4021315	1.0	PC
080	SILICONE SEALANT CLEAR	4508976	0.1	PC
090	CS-A 5100Z ANTI-SEIZE	4021324	0.1	PC
100	BI 50 LOCKNUT 1/2 TIGER GRIP STEEL	3800600	2.0	PC
110	ABRLETTN CG-5050S GORD STRAIN RELIEF 0.500-0.625 CABLE 1/2 ST HUB APPL ETON	3800471	2.0	PC
120	WIRE 14/3 SDV/SDV 600V BLACK	3807095	10.0	PC
070	1000' REEL	1413072	1.0	PC
080	HEADER IS MOUNTED ON SHEET METAL AND CONNECTED TO COIL WITH 1" TUBES 470# SKIDED WEIGHT	3980002	1.0	PC
090	VALVE ANGLE REFERIG 5/8"	2730005	1.0	PC
100	C-3055 FILTER DRIER 5/8" SPORLAN	2710008	1.0	PC
110	E14S850 VALVE SOLENOID 5/8"	0608319	1.0	ASSEM
120	REQUIRES MKC-2E COIL SPORLAN MKC-2E SOLENOID COIL 24V AC 50/60HZ ASSEMBLY WITH CABLE IS 0608319 SPD RAN	2710113	1.0	PC
020	1520S CONNECTOR. DIN 43650 18MM W/ 5 METER GRAY PVC CABLE 407C 0-230 V 1.8 GA WIRE. UL RECOGNIZED E172930 MURKRELEKTRONIK NEW PART NUMBER 7000-18081-2160900	4807100	1.0	PC
130	SA-155 SIGHT GLASS 5/8 DDF	2720004	1.0	PC
010	SPORLAN DVE-15-C VALVE EXPANSION 7/8 DDF IN X 1-1/8 DDF OUT STRAIGHT T CONNECTIONS SPORLAN	2760112	1.0	PC

INSTALL HEAT TAPE ON CONDENSER HEADER BEFORE INSTALLING IN UNIT. RUN THE HEAT TAPE AROUND HEADER AND ATTACH WITH HOSE CLAMPS. USE 10FT. OF HEAT TAPE PER CONDENSER. HEAT TAPE TO BE INSULATED WITH 1/2" OF ARMAFLEX AFTER HEAT TAPE IS INSTALLED

LOW AMBIENT KIT OPTION
* NOTE REFER TO PRINT 0612139 FOR BOM COMPONENTS

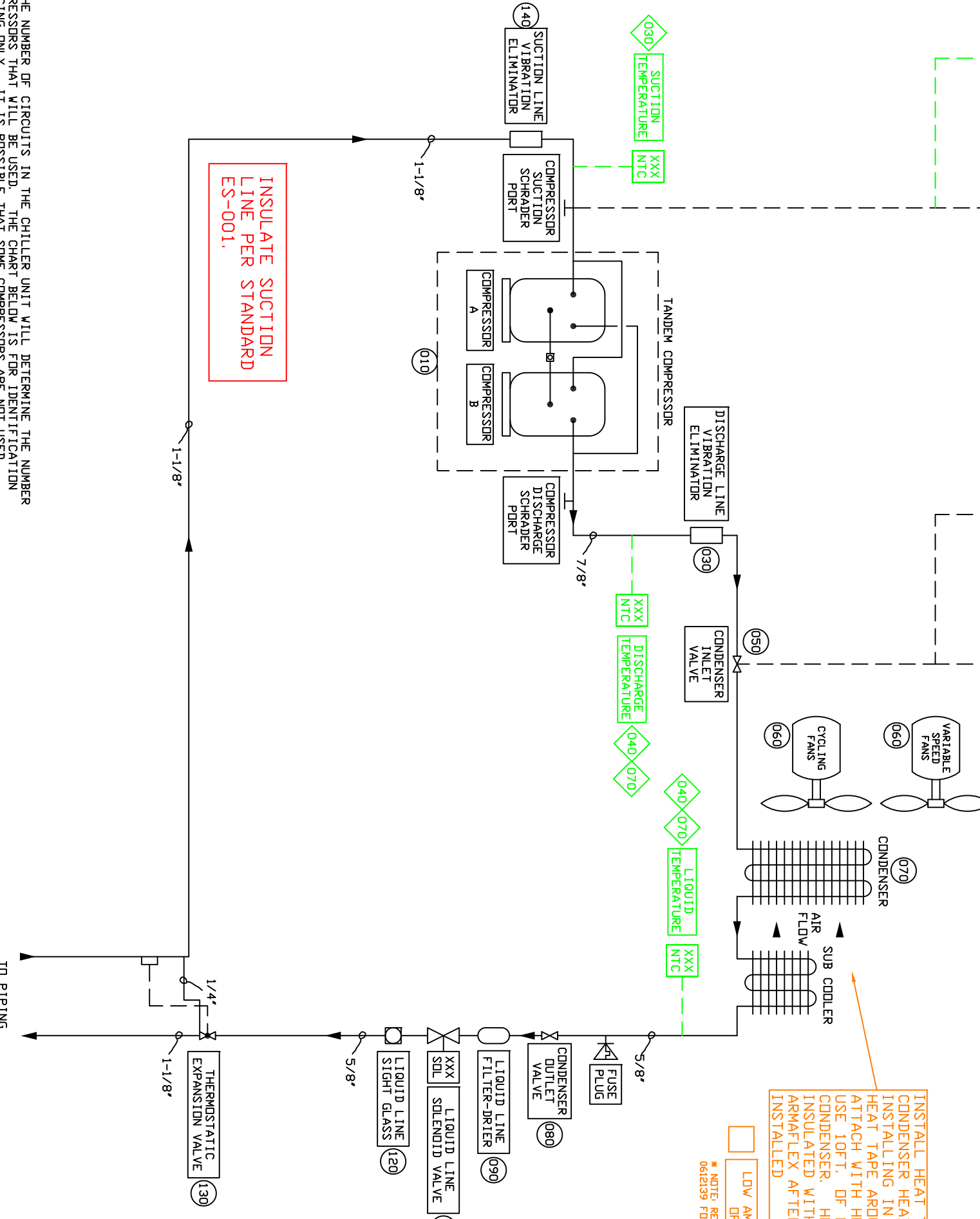

INSULATE SUCTION LINE PER STANDARD ES-001.

COMPONENT IDENTIFICATION

COMPRESSOR	HIGH PRESSURE SWITCH	DISCHARGE TRANSDUCER	DISCHARGE TEMPERATURE	LIQUID LINE TEMPERATURE	LOW PRESSURE SWITCH	SUCTION TRANSDUCER	SUCTION TEMPERATURE	LIQUID LINE SOLENOID
1A & 1B	715PS	710PT	708NTC	753NTC	752PS	711PT	709NTC	738SOL
2A & 2B	815PS	810PT	808NTC	853NTC	852PS	811PT	809NTC	838SOL
3A & 3B	915PS	910PT	908NTC	953NTC	952PS	911PT	909NTC	938SOL
4A & 4B	1015PS	1010PT	1008NTC	1053NTC	1052PS	1011PT	1009NTC	1038SOL

NOTE: THE NUMBER OF CIRCUITS IN THE CHILLER UNIT WILL DETERMINE THE NUMBER OF COMPRESSORS THAT WILL BE USED. THE CHART BELOW IS FOR IDENTIFICATION REFERENCING ONLY. IT IS POSSIBLE THAT SOME COMPRESSORS ARE NOT USED.

ALL DIMENSIONS ARE IN INCHES
THIS PRINT CONTAINS INFORMATION PROPRIETARY TO DIMPLEX THERMAL SOLUTIONS. MAY NOT BE DUPLICATED, REPRODUCED, OR SHARED IN ANY WAY WITHOUT THE EXPRESSED WRITTEN CONSENT OF DIMPLEX THERMAL SOLUTIONS.
CONFIDENTIAL AND PROPRIETARY

DESIGN BY: MAR
DATE: 01/07/10
DRAWN BY: MAR
PAGE 1 OF 1
KALAMAZOO, MI
PH (800) 968-5665
WWW.DIMPLEXTHERMAL.COM
Thermal Solutions
Schneider Electric

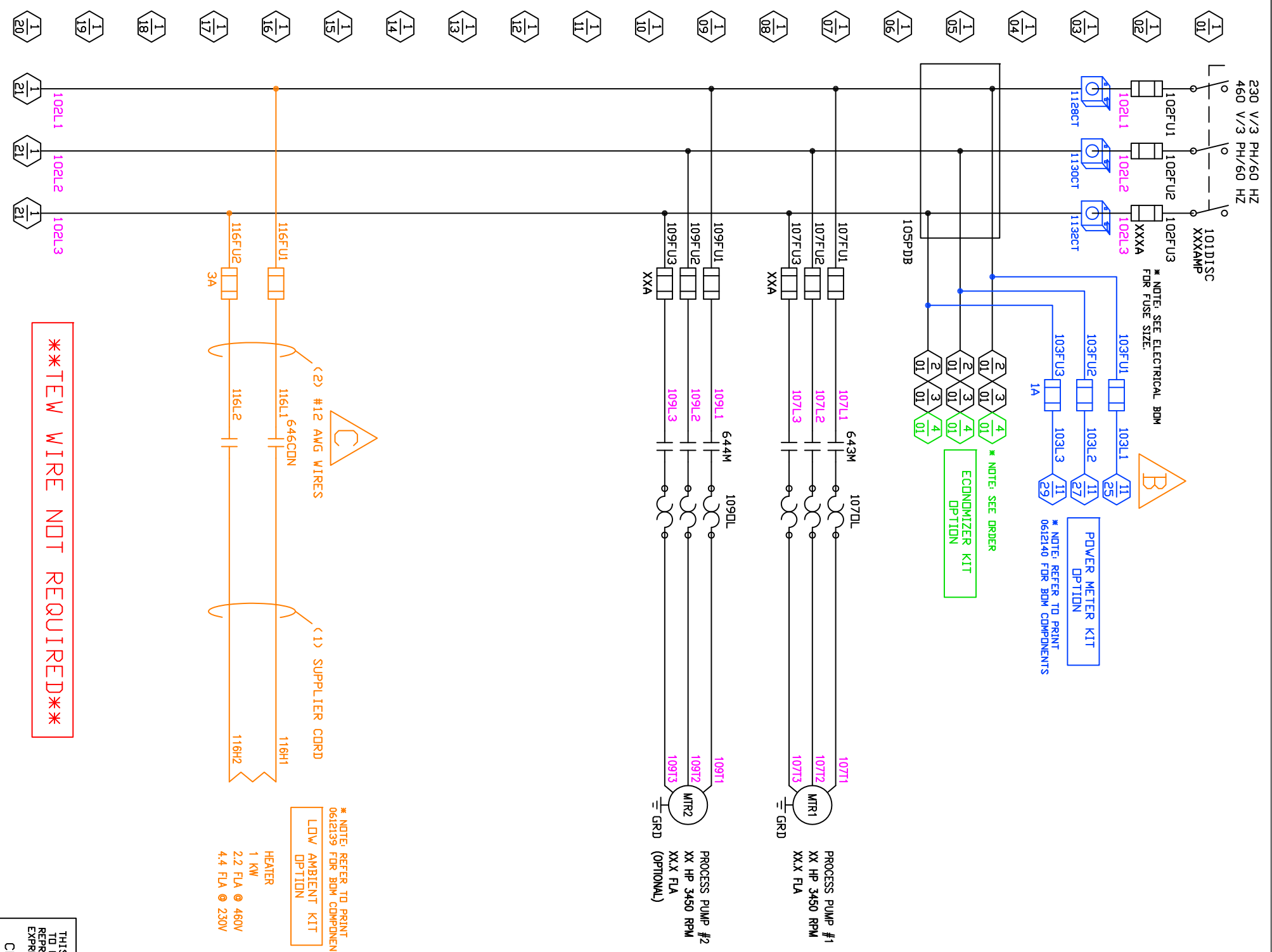

PUMP DATA TABLE

HORSEPOWER	ITEM #	VOLTAGE	FLA (AMPS)	PUMP WIRE (AWG)	FUSE (AMPS)	OVERLOAD SETTING
1.5	1785003	230/3/60	7.0	14	15	8.7
1.5	1785003	460/3/60	3.5	14	15	4.3
2	1785004	230/3/60	11.6	12	20	14.5
2	1785004	460/3/60	5.8	14	15	7.2
3	1785007	230/3/60	12.6	12	20	15.7
3	1785007	460/3/60	6.3	14	15	7.8

TRANSFORMER DATA TABLE

FUSE #	UNIT VOLTAGE	PRIMARY WIRE (AWG)	FUSE (AMPS)	PRIMARY JUMPER
130FU-3	230/3/60	12	6	HI-H3 & H2-H4
130FU-3	460/3/60	12	3	H2-H3
136FU-2	230/3/60	12	6	HI-H3 & H2-H4
136FU-2	460/3/60	12	3	H2-H3

ALL DIMENSIONS ARE IN INCHES

THIS PRINT CONTAINS INFORMATION PROPRIETARY TO KOOLANT COOLERS. MAY NOT BE DUPLICATED, REPRODUCED, OR SHARED IN ANY WAY WITHOUT THE EXPRESSED WRITTEN CONSENT OF KOOLANT COOLERS. CONFIDENTIAL AND PROPRIETARY

DATE: 02/16/10
 DESCRIPTION OF REVISION: 130FU3
 APPROVED BY: [Signature]

DESIGN BY: MAR
 DRAWN BY: MAR
 DATE: 01/07/10
 PAGE 1 OF X
 W0(-)-(-)(2)P-M
 ELECTRICAL

KALAMAZOO, MI
 PH (800) 968-5665
 WWW.DIMPLEXTHERMAL.COM

SCHNEIDER
 THERMAL SOLUTIONS
 DRAWING NO. 443394

TEW WIRE NOT REQUIRED

NOTE: REFER TO PRINT 0612139 FOR BDM COMPONENTS

LOW AMBIENT KIT OPTION

HEATER
 1 KW
 2.2 FLA @ 460V
 4.4 FLA @ 230V

NOTE: REFER TO PRINT 0612139 FOR BDM COMPONENTS

LOW AMBIENT KIT OPTION

NOTE: SEE ORDER ECONDMIZER KIT OPTION

NOTE: SEE ORDER ECONDMIZER KIT OPTION

HEAT TAPE AROUND CONDENSER HEADER 60W PER CIRCUIT

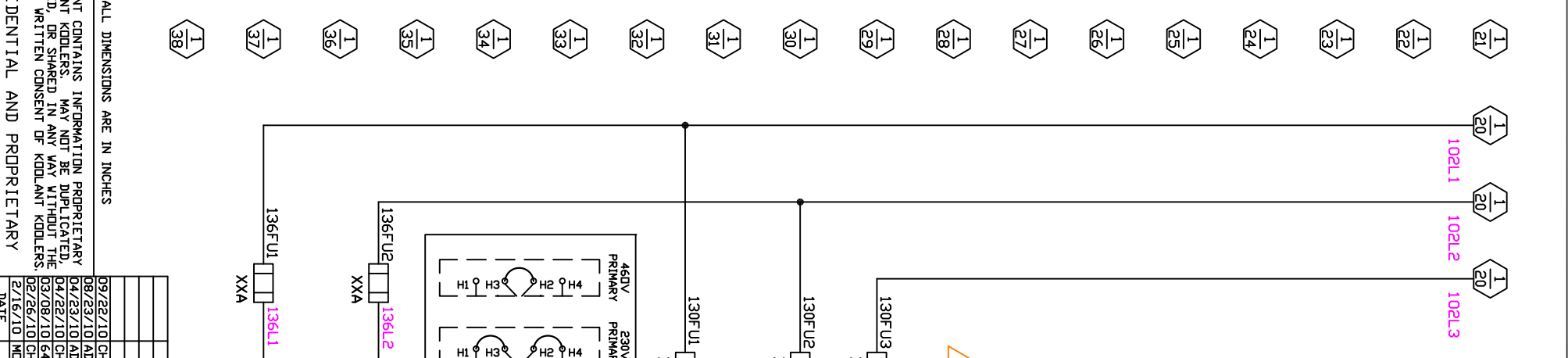
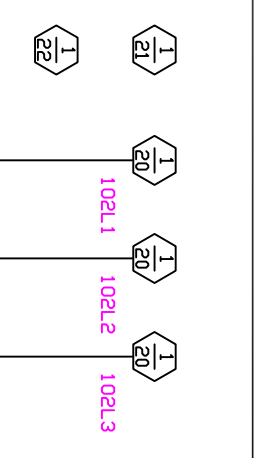

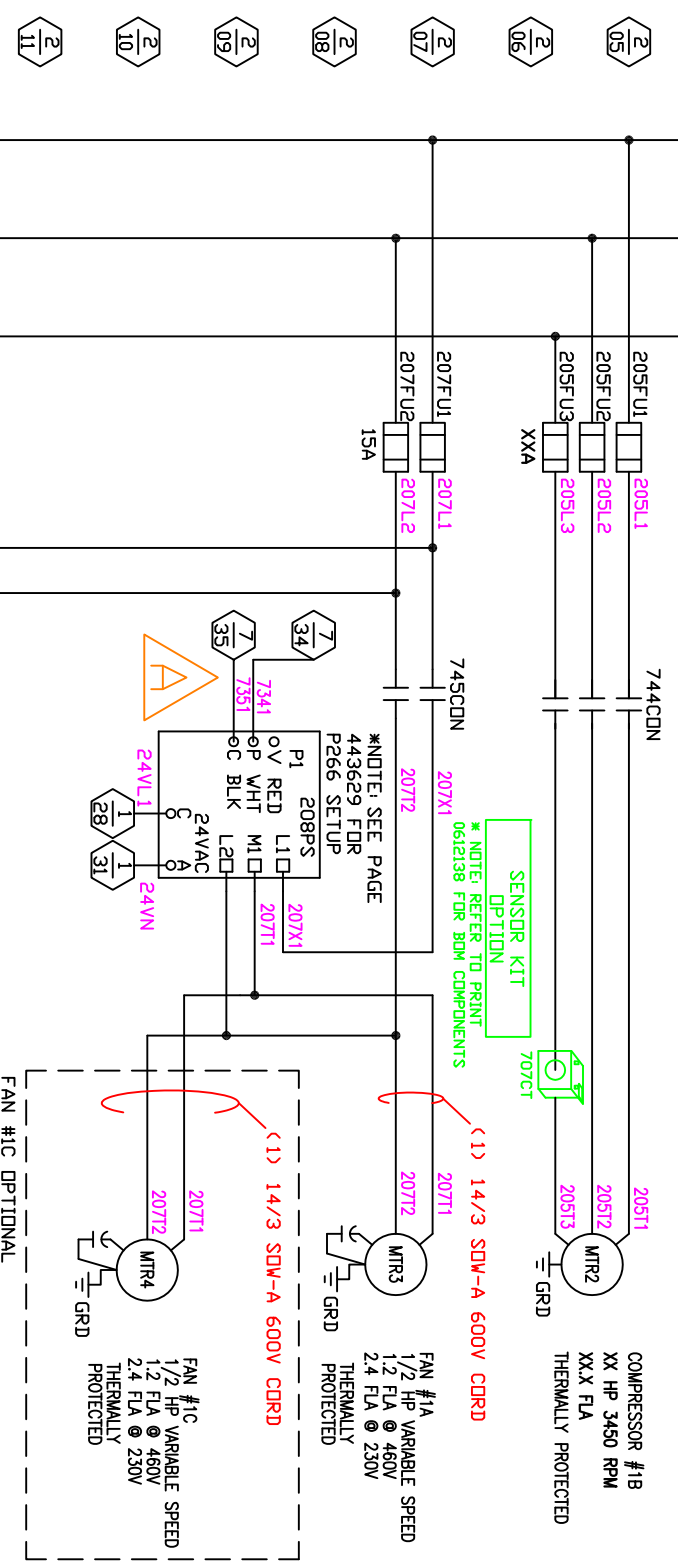
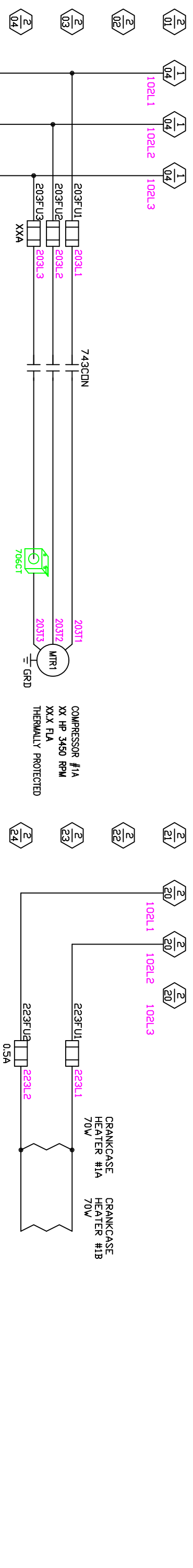

COMPRESSOR INFO

COMPRESSOR (HP)	VOLTAGE (VOLTS)	COMPRESSOR FLA (AMPS)	203FU1-3/205FU1-3 (AMPS)	CIRCUIT FLA	WIRE (AWG)
5	230	23.6	30	57.4	10
5	460	11.8	20	28.7	14
7.5	230	33	45	76.2	8
7.5	460	16.5	25	38.1	10
10	230	40	50	90.2	8
10	460	20	25	45.1	10

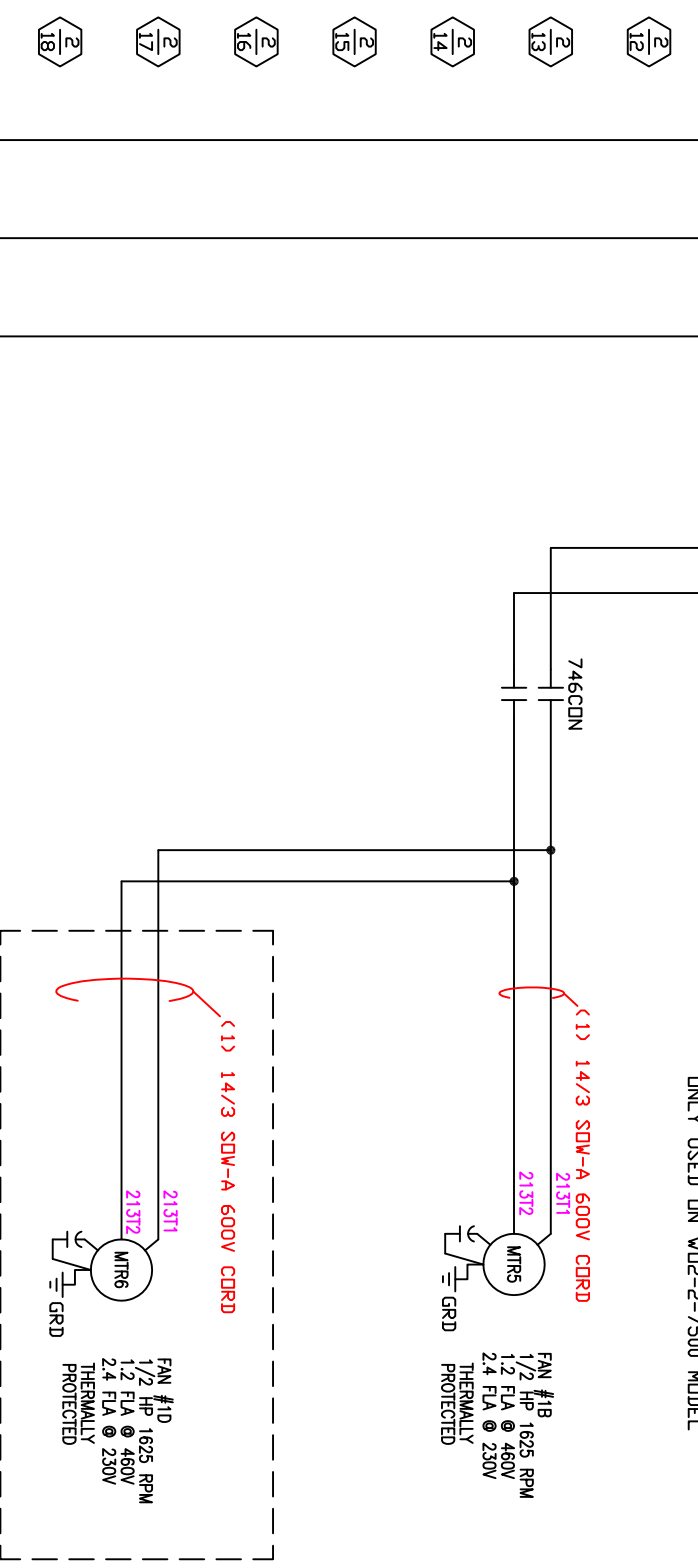

ALL DIMENSIONS ARE IN INCHES

THIS PRINT CONTAINS INFORMATION PROPRIETARY TO KOOLANT COOLERS. MAY NOT BE DUPLICATED, REPRODUCED, OR SHARED IN ANY WAY WITHOUT THE EXPRESSED WRITTEN CONSENT OF KOOLANT COOLERS. CONFIDENTIAL AND PROPRIETARY

DESIGN BY: MAR	DATE: 01/07/10	DRAWN BY: MAR	PAGE 2 OF X
05/04/10 SHP 460V COMP VAS 12 ANG 01/21/10 UPDATED 208PS WIRING		KALAMAZOO, MI PH (800) 968-5665 WWW.DIMPLEXTHERMAL.COM	
DATE	DESCRIPTION OF REVISION	APPROVED BY	DRAWING NO. 443395

W0()-()- (2)P-M
ELECTRICAL

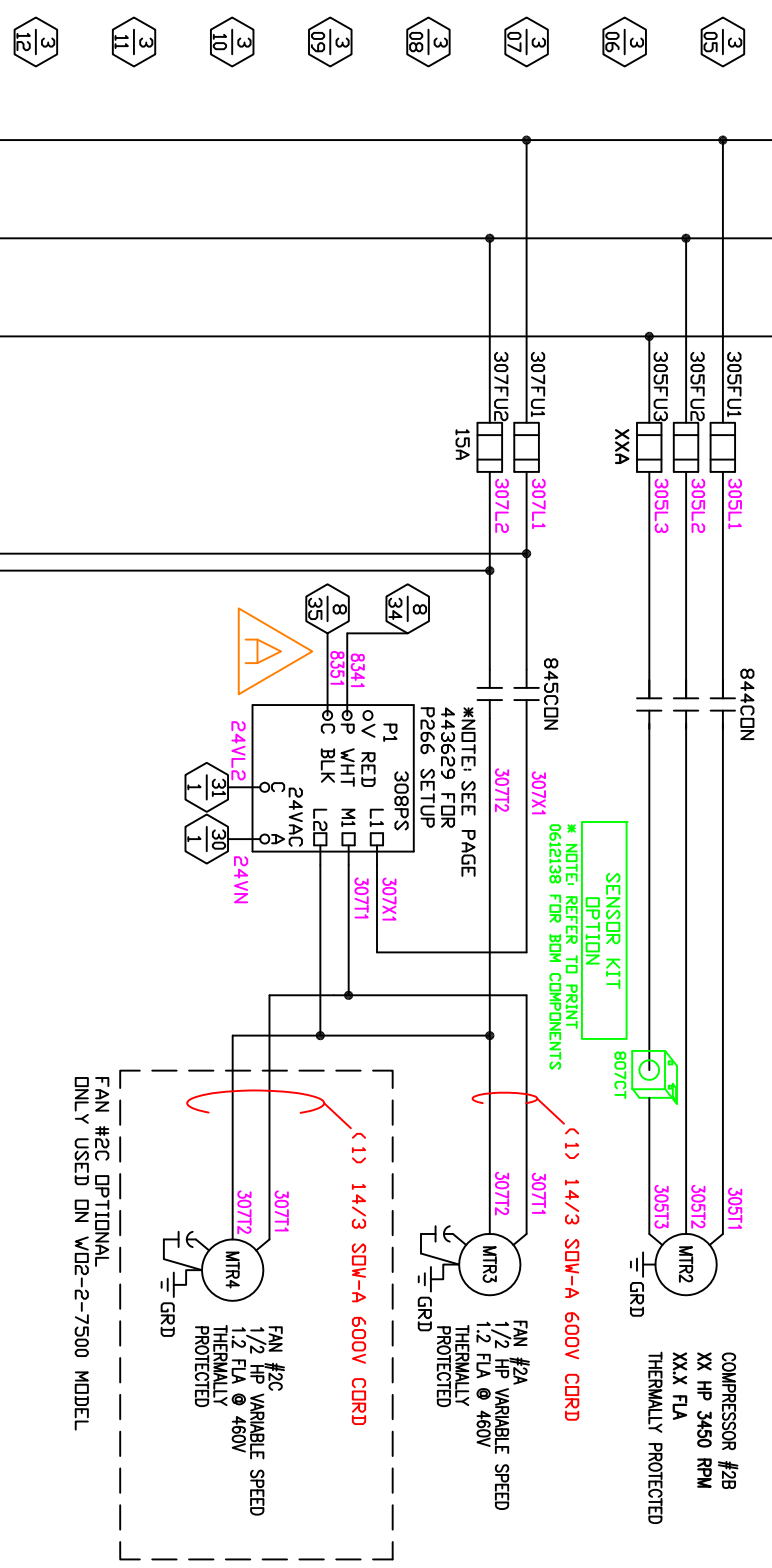
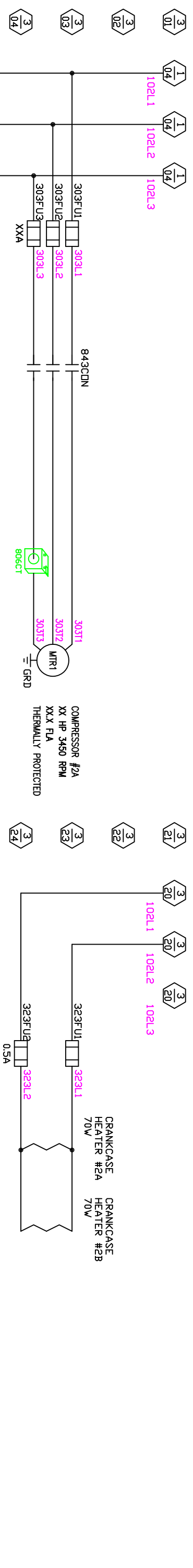

COMPRESSOR INFO

COMPRESSOR (HP)	VOLTAGE (VOLTS)	COMPRESSOR FLA (AMPS)	203FU1-3/205FU1-3 (AMPS)	CIRCUIT FLA	WIRE (AWG)
5	230	23.6	30	57.4	10
5	460	11.8	20	28.7	14
7.5	230	33	45	76.2	8
7.5	460	16.5	25	38.1	10
10	230	40	50	90.2	8
10	460	20	25	45.1	10

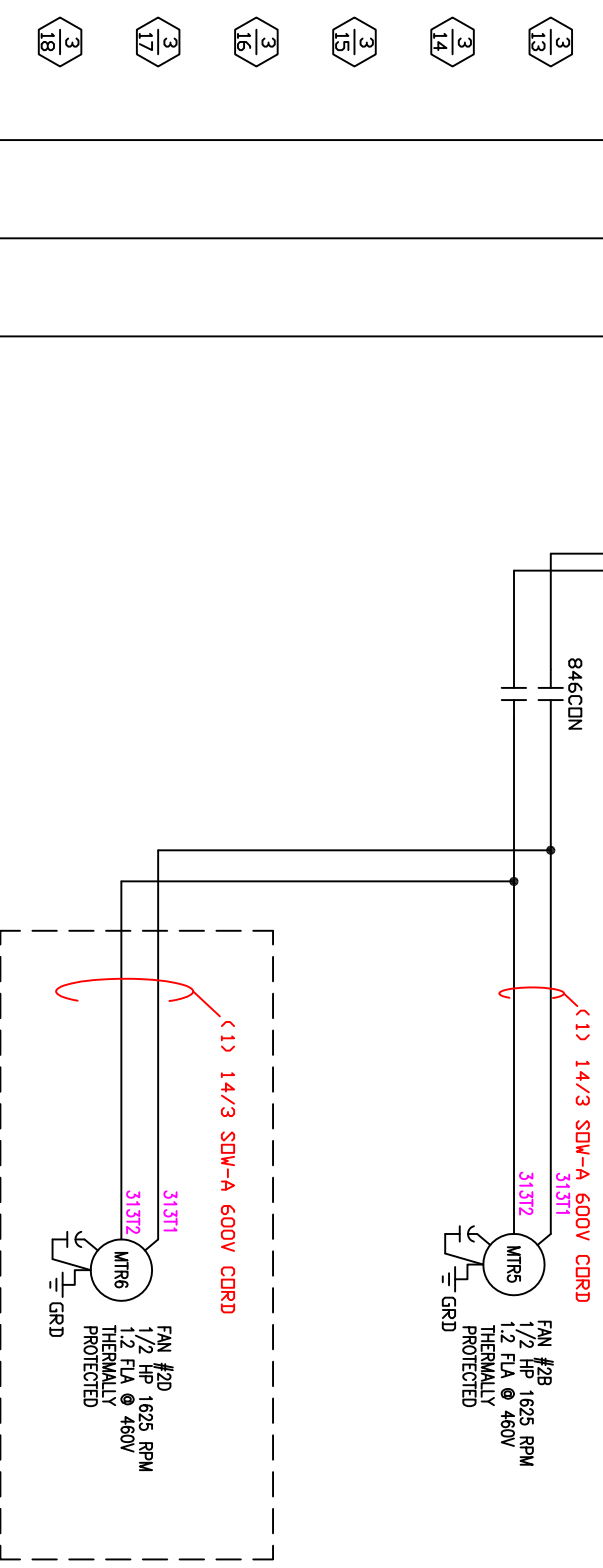

ALL DIMENSIONS ARE IN INCHES

FAN #2D OPTIONAL
ONLY USED ON W02-2-7500 MODEL

FAN #2B
1/2 HP 1625 RPM
THERMALLY PROTECTED

FAN #2C OPTIONAL
ONLY USED ON W02-2-7500 MODEL

FAN #2A
1/2 HP VARIABLE SPEED
THERMALLY PROTECTED

COMPRESSOR #2A
XX HP 3450 RPM
XXX FLA
THERMALLY PROTECTED

COMPRESSOR #2B
XX HP 3450 RPM
XXX FLA
THERMALLY PROTECTED

CRANKCASE HEATER #2A 70W

CRANKCASE HEATER #2B 70W

SENSOR KIT
OPTIONAL
907CT

*NOTE: REFER TO PRINT 0612138 FOR BOM COMPONENTS

*NOTE: SEE PAGE 443629 FOR P266 SETUP

308PS
P1 308PS
OV RED L1
OP WHT M1
OC BLK L2
24VAC
24VDC
24VDC

845CDN
846CDN

307FU1 307L1
307FU2 307L2
15A

305FU1 305L1
305FU2 305L2
305FU3 305L3
XXA

303FU1 303L1
303FU2 303L2
303FU3 303L3
XXA

102L1
102L2
102L3

30311
30312
30313
MTR1
MTR2
MTR3
MTR4
MTR5
MTR6

30711
30712
30713
30714
30715
30716

30511
30512
30513
30514
30515
30516

30311
30312
30313
30314
30315
30316

323FU1 323L1
323FU2 323L2
0.5A

31311
31312
31313
31314
31315
31316

31317
31318
31319
31320
31321
31322

31323
31324
31325
31326
31327
31328

31329
31330
31331
31332
31333
31334

31335
31336
31337
31338
31339
31340

31341
31342
31343
31344
31345
31346

31347
31348
31349
31350
31351
31352

31353
31354
31355
31356
31357
31358

31359
31360
31361
31362
31363
31364

31365
31366
31367
31368
31369
31370

31371
31372
31373
31374
31375
31376

31377
31378
31379
31380
31381
31382

31383
31384
31385
31386
31387
31388

31389
31390
31391
31392
31393
31394

31395
31396
31397
31398
31399
31400

31401
31402
31403
31404
31405
31406

31407
31408
31409
31410
31411
31412

31413
31414
31415
31416
31417
31418

31419
31420
31421
31422
31423
31424

31425
31426
31427
31428
31429
31430

31431
31432
31433
31434
31435
31436

31437
31438
31439
31440
31441
31442

31443
31444
31445
31446
31447
31448

31449
31450
31451
31452
31453
31454

31455
31456
31457
31458
31459
31460

31461
31462
31463
31464
31465
31466

31467
31468
31469
31470
31471
31472

31473
31474
31475
31476
31477
31478

31479
31480
31481
31482
31483
31484

31485
31486
31487
31488
31489
31490

31491
31492
31493
31494
31495
31496

31497
31498
31499
31500
31501
31502

31503
31504
31505
31506
31507
31508

31509
31510
31511
31512
31513
31514

31515
31516
31517
31518
31519
31520

31521
31522
31523
31524
31525
31526

31527
31528
31529
31530
31531
31532

31533
31534
31535
31536
31537
31538

31539
31540
31541
31542
31543
31544

31545
31546
31547
31548
31549
31550

31551
31552
31553
31554
31555
31556

31557
31558
31559
31560
31561
31562

31563
31564
31565
31566
31567
31568

31569
31570
31571
31572
31573
31574

31575
31576
31577
31578
31579
31580

31581
31582
31583
31584
31585
31586

31587
31588
31589
31590
31591
31592

31593
31594
31595
31596
31597
31598

31599
31600
31601
31602
31603
31604

31605
31606
31607
31608
31609
31610

31611
31612
31613
31614
31615
31616

31617
31618
31619
31620
31621
31622

31623
31624
31625
31626
31627
31628

31629
31630
31631
31632
31633
31634

31635
31636
31637
31638
31639
31640

31641
31642
31643
31644
31645
31646

31647
31648
31649
31650
31651
31652

31653
31654
31655
31656
31657
31658

31659
31660
31661
31662
31663
31664

31665
31666
31667
31668
31669
31670

31671
31672
31673
31674
31675
31676

31677
31678
31679
31680
31681
31682

31683
31684
31685
31686
31687
31688

31689
31690
31691
31692
31693
31694

31695
31696
31697
31698
31699
31700

31701
31702
31703
31704
31705
31706

31707
31708
31709
31710
31711
31712

31713
31714
31715
31716
31717
31718

31719
31720
31721
31722
31723
31724

31725
31726
31727
31728
31729
31730

31731
31732
31733
31734
31735
31736

31737
31738
31739
31740
31741
31742

31743
31744
31745
31746
31747
31748

31749
31750
31751
31752
31753
31754

31755
31756
31757
31758
31759
31760

31761
31762
31763
31764
31765
31766

31767
31768
31769
31770
31771
31772

31773
31774
31775
31776
31777
31778

31779
31780
31781
31782
31783
31784

31785
31786
31787
31788
31789
31790

31791
31792
31793
31794
31795
31796

31797
31798
31799
31800
31801
31802

31803
31804
31805
31806
31807
31808

31809
31810
31811
31812
31813
31814

31815
31816
31817
31818
31819
31820

31821
31822
31823
31824
31825
31826

31827
31828
31829
31830
31831
31832

31833
31834
31835
31836
31837
31838

31839
31840
31841
31842
31843
31844

31845
31846
31847
31848
31849
31850

31851
31852
31853
31854
31855
31856

31857
31858
31859
31860
31861
31862

31863
31864
31865
31866
31867
31868

31869
31870
31871
31872
31873
31874

31875
31876
31877
31878
31879
31880

31881
31882
31883
31884
31885
31886

31887
31888
31889
31890
31891
31892

31893
31894
31895
31896
31897
31898

31899
31900
31901
31902
31903
31904

31905
31906
31907
31908
31909
31910

31911
31912
31913
31914
31915
31916

31917
31918
31919
31920
31921
31922

31923
31924
31925
31926
31927
31928

31929
31930
31931
31932
31933
31934

31935
31936
31937
31938
31939
31940

31941
31942
31943
31944
31945
31946

31947
31948
31949
31950
31951
31952

31953
31954
31955
31956
31957
31958

31959
31960
31961
31962
31963
31964

31965
31966
31967
31968
31969
31970

31971
31972
31973
31974
31975
31976

31977
31978
31979
31980
31981
31982

31983
31984
31985
31986
31987
31988

31989
31990
31991
31992
31993
31994

31995
31996
31997
31998
31999
32000

32001
32002
32003
32004
32005
32006

32007
32008
32009
32010
32011
32012

32013
32014
32015
32016
32017
32018

32019
32020
32021
32022
32023
32024

32025
32026
32027
32028
32029
32030

32031
32032
32033
32034
32035
32036

32037
32038
32039
32040
32041
32042

32043
32044
32045
32046
32047
32048

32049
32050
32051
32052
32053
32054

32055
32056
32057
32058
32059
32060

32061
32062
32063
32064
32065
32066

32067
32068
32069
32070
32071
32072

32073
32074
32075
32076
32077
32078

32079
32080
32081
32082
32083
32084

32085
32086
32087
32088
32089
32090

32091
32092
32093
32094
32095
32096

32097
32098
32099
32100
32101
32102

32103
32104
32105
32106
32107
32108

32109
32110
32111
32112
32113
32114

32115
32116
32117
32118
32119
32120

32121
32122
32123
32124
32125
32126

32127
32128
32129
32130
32131
32132

32133
32134
32135
32136
32137
32138

32139
32140
32141
32142
32143
32144

32145
32146
32147
32148
32149
32150

32151
32152
32153
32154
32155
32156

32157
32158
32159
32160
32161
32162

32163
32164
32165
32166
32167
32168

32169
32170
32171
32172
32173
32174

32175
32176
32177
32178
32179
32180

32181
32182
32183
32184
32185
32186

32187
32188
32189
32190
32191
32192

32193
32194
32195
32196
32197
32198

32199
32200
32201
32202
32203
32204

32205
32206
32207
32208
32209
32210

32211
32212
32213
32214
32215
32216

32217
32218
32219
32220
32221
32222

32223
32224
32225
32226
32227
32228

32229
32230
32231
32232
32233
32234

32235
32236
32237
32238
32239
32240

32241
32242
32243
32244
32245
32246

32247
32248
32249
32250
32251
32252

32253
32254
32255
32256
32257
32258

32259
32260
32261
32262
32263
32264

32265
32266
32267
32268
32269
32270

32271
32272
32273
32274
32275
32276

32277
32278
32279
32280
32281
32282

32283
32284
32285
32286
32287
32288

32289
32290
32291
32292
32293
32294

32295
32296
32297
32298
32299
32300

32301
32302
32303
32304
32305
32306

32307
32308
32309
32310
32311
32312

32313
32314
32315
32316
32317
32318

32319
32320
32321
32322
32323
32324

32325
32326
32327
32328
32329
32330

32331
32332
32333
32334
32335
32336

32337
32338
32339
32340
32341
32342

32343
32344
32345
32346
32347
32348

32349
32350
32351
32352
32353
32354

32355
32356
32357
32358
32359
32360

32361
32362
32363
32364
32365
32366

32367
32368
32369
32370
32371
32372

32373
32374
32375
32376
32377
32378

32379
32380
32381
32382
32383
32384

32385
32386
32387
32388
32389
32390

32391
32392
32393
32394
32395
32396

32397
32398
32399
32400
32401
32402

32403
32404
32405
32406
32407
32408

32409
32410
32411
32412
32413
32414

32415
32416
32417
32418
32419
32420

32421
32422
32423
32424
32425
32426

32427
32428
32429
32430
32431
32432

32433
32434
32435
32436
32437
32438

32439
32440
32441
32442
32443
32444

32445
32446
32447
32448
32449
32450

32451
32452
32453
32454
32455
32456

32457
32458
32459
32460
32461
32462

32463
32464
32465
32466
32467
32468

32469
32470
32471
32472
32473
32474

32475
32476
32477
32478
32479
32480

32481
32482
32483
32484
32485
32486

32487
32488
32489
32490
32491
32492

32493
32494
32495
32496
32497
32498

32499
32500
32501
32502
32503
32504

32505
32506
32507
32508
32509
32510

32511
32512
32513
32514
32515
32516

32517
32518
32519
32520
32521
32522

32523
32524
32525
32526
32527
32528

32529
3253

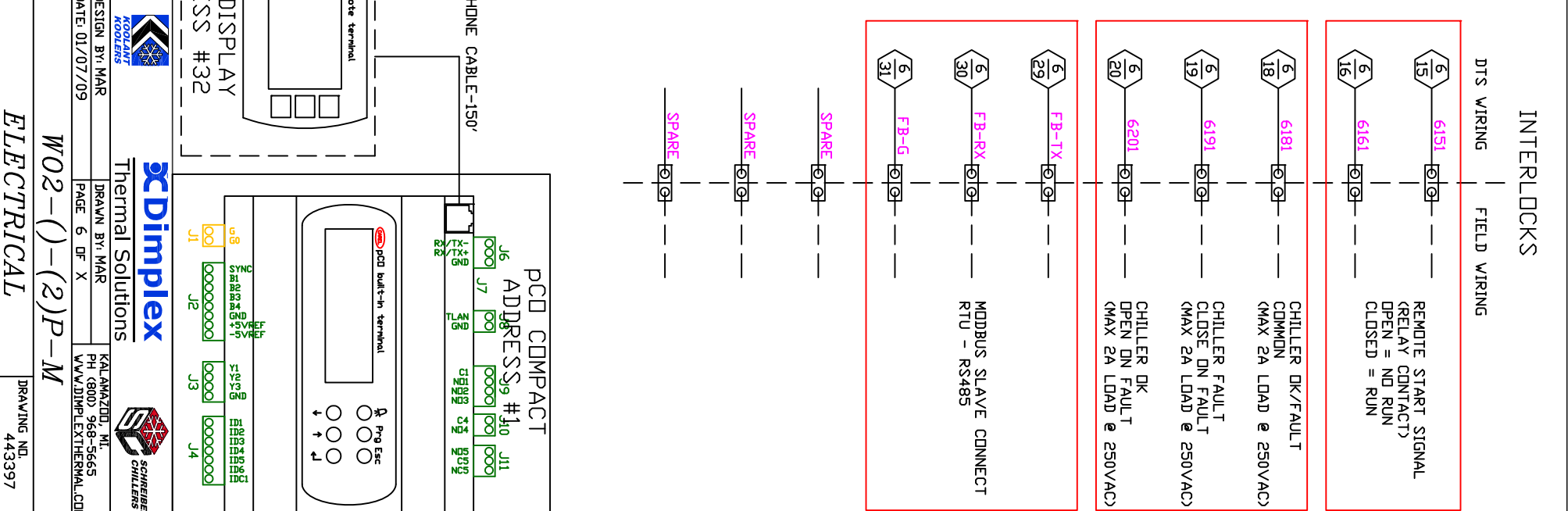
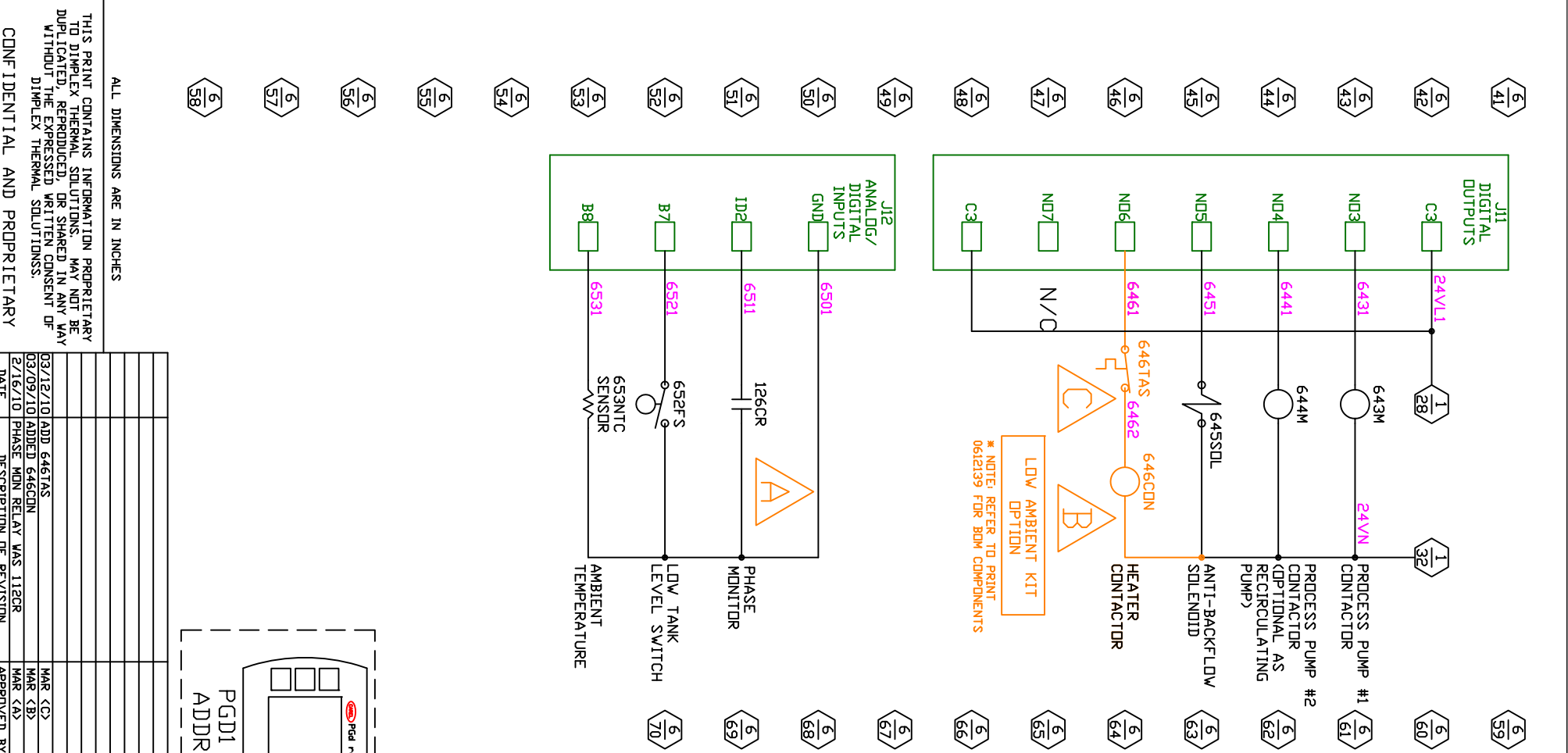
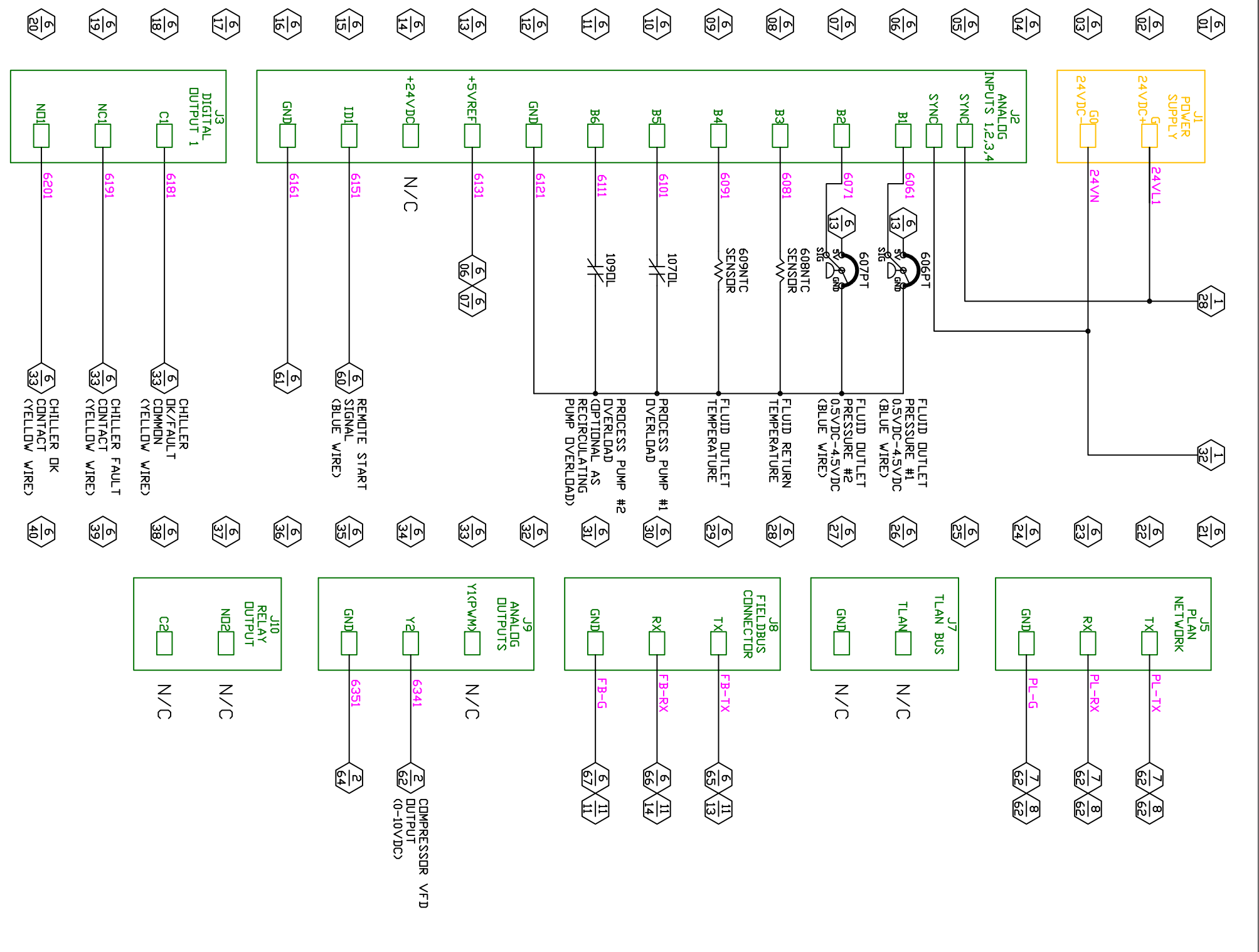

ALL DIMENSIONS ARE IN INCHES

THIS PRINT CONTAINS INFORMATION PROPRIETARY TO DIMPLEX THERMAL SOLUTIONS. MAY NOT BE DUPLICATED, REPRODUCED, OR SHARED IN ANY WAY WITHOUT THE EXPRESSED WRITTEN CONSENT OF DIMPLEX THERMAL SOLUTIONS.

CONFIDENTIAL AND PROPRIETARY

DATE	DESCRIPTION OF REVISION	APPROVED BY
03/12/10	ADD 646TAS	MAR <D>
03/09/10	ADD 646CCN	MAR <D>
2/16/10	PHASE MON RELAY WAS 112CR	MAR <D>

3C Dimplex Thermal Solutions

DESIGN BY: MAR
 DRAWN BY: MAR
 DATE: 01/07/09

KALAMAZOO, MI
 PH (800) 968-5665
 WWW.DIMPLEXTHERMAL.COM

W02-()-(?)P-M

ELECTRICAL

DRAWING NO: 443397

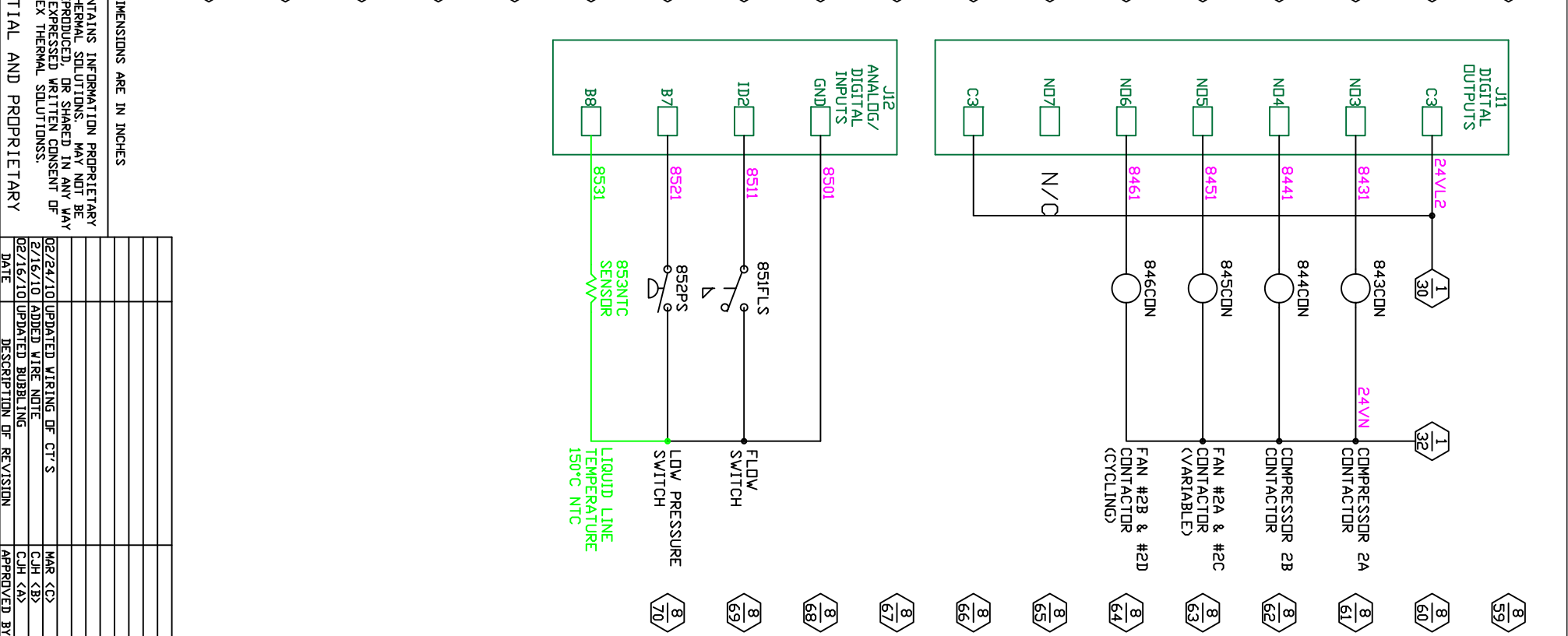
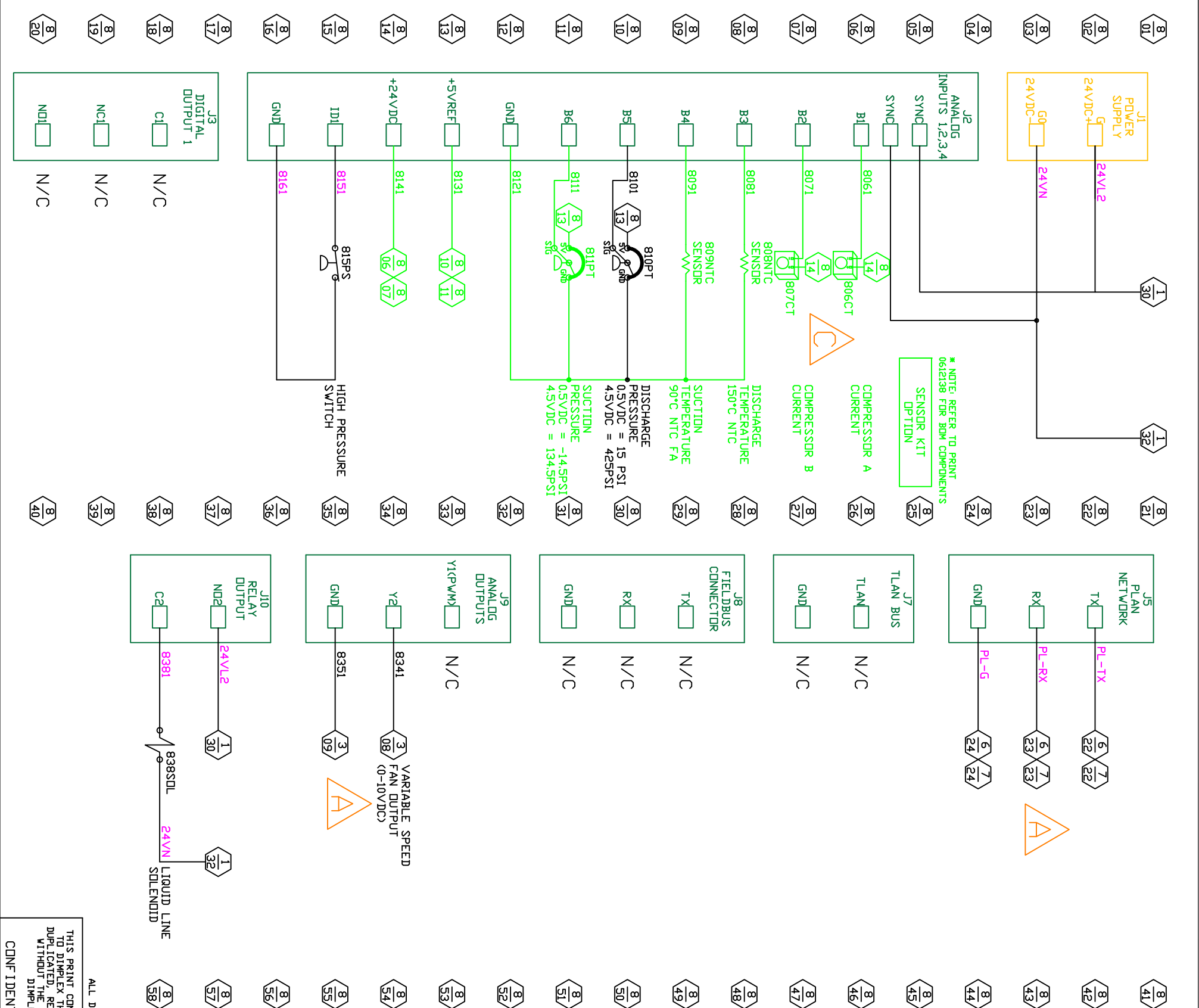

ALL DIGITAL INPUTS, ANALOG INPUTS, AND ANALOG OUTPUTS USE BLUE WIRE.

THIS PRINT CONTAINS INFORMATION PROPRIETARY TO DIMPLEX THERMAL SOLUTIONS. MAY NOT BE DUPLICATED, REPRODUCED, OR SHARED IN ANY WAY WITHOUT THE EXPRESSED WRITTEN CONSENT OF DIMPLEX THERMAL SOLUTIONS.

ALL DIMENSIONS ARE IN INCHES

DATE	DESCRIPTION OF REVISION	APPROVED BY
02/24/10	UPDATED WIRING OF CT'S	MAR <S>
2/16/10	ADDED WIRE NOTE	CJH <S>
02/16/10	UPDATED BUBBLING	

3C Dimplex Thermal Solutions
 KALAMAZOO, MI
 PH (800) 968-5665
 WWW.DIMPLEXTHERMAL.COM

DESIGN BY: MAR
 DRAWN BY: MAR
 DATE: 01/07/10
 PAGE: 8 OF X

W02-()-(?)P-M
 ELECTRICAL

DRAWING NO: 443399

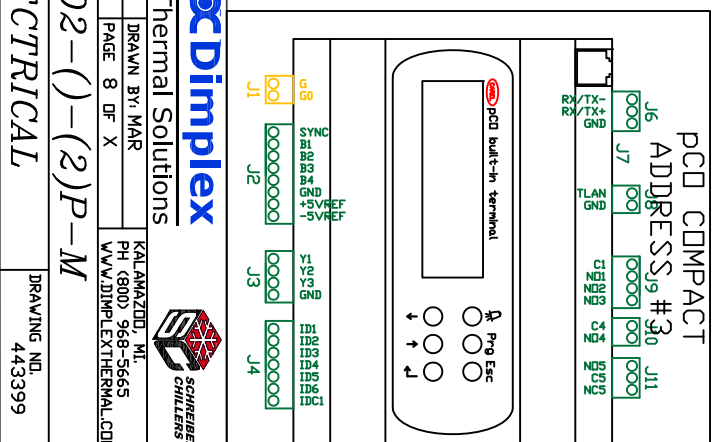

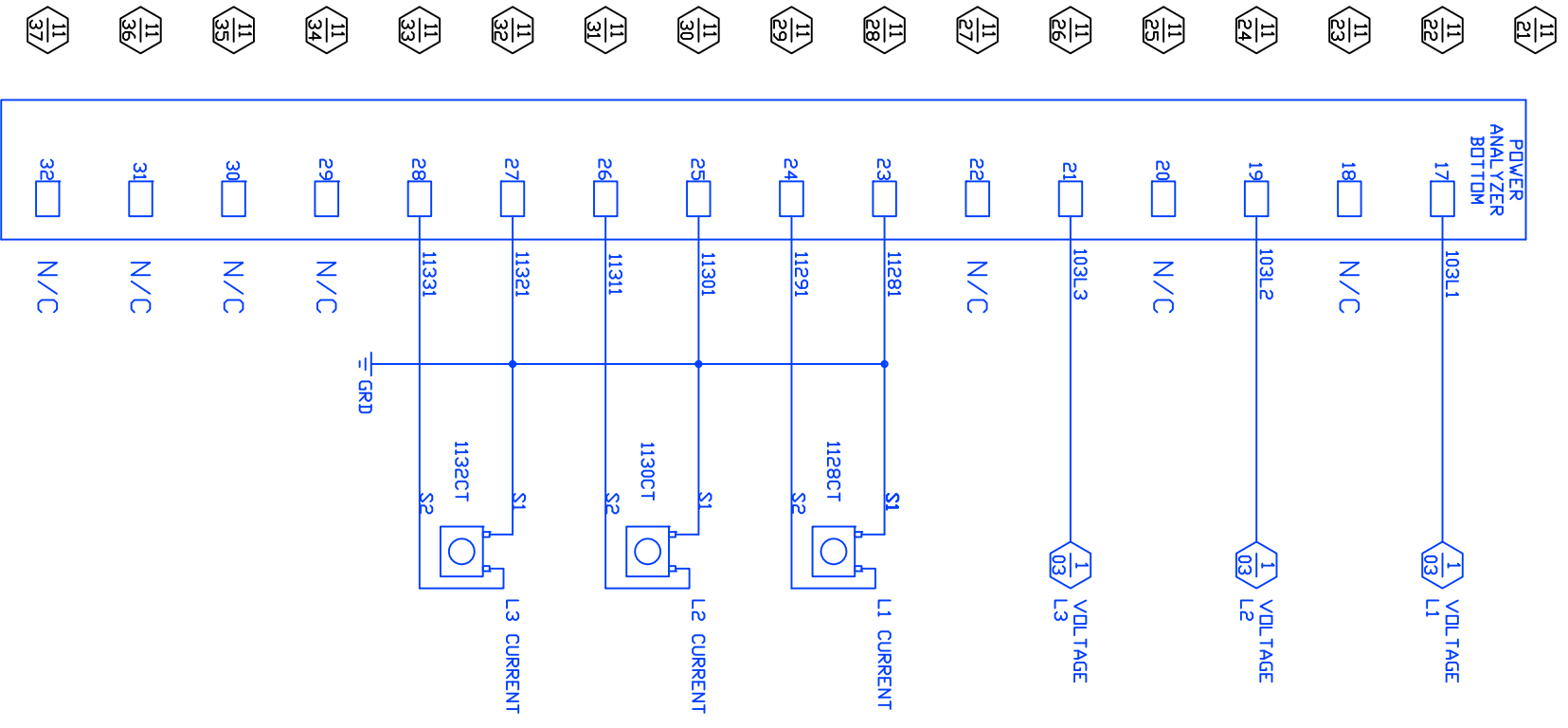
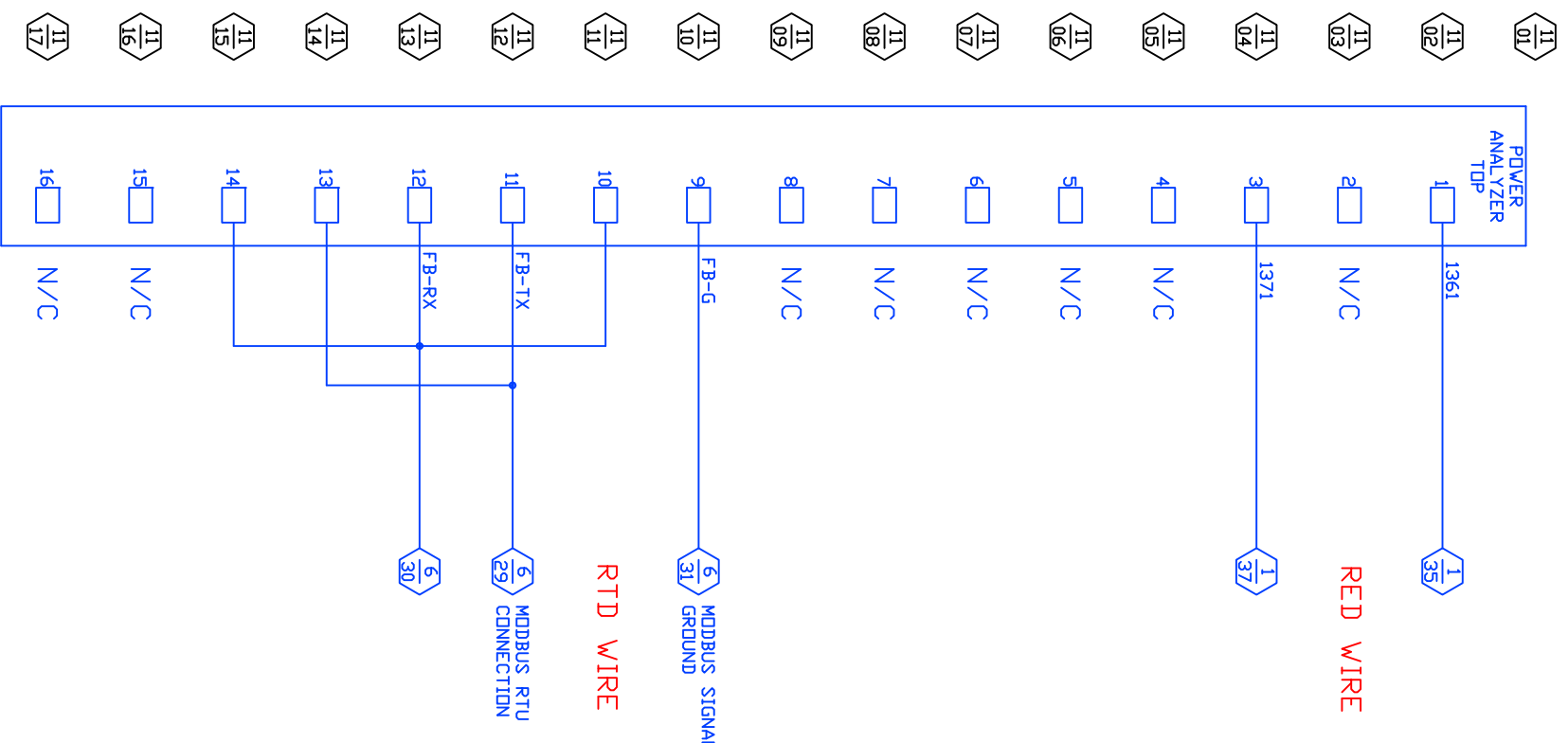

POWER METER KIT
OPTION

* NOTE: REFER TO PRINT
0612140 FOR BDM COMPONENTS

- 11/01
- 11/02
- 11/03
- 11/04
- 11/05
- 11/06
- 11/07
- 11/08
- 11/09
- 11/10
- 11/11
- 11/12
- 11/13
- 11/14
- 11/15
- 11/16
- 11/17
- 11/18
- 11/19
- 11/20

- 11/21
- 11/22
- 11/23
- 11/24
- 11/25
- 11/26
- 11/27
- 11/28
- 11/29
- 11/30
- 11/31
- 11/32
- 11/33
- 11/34
- 11/35
- 11/36
- 11/37
- 11/38
- 11/39
- 11/40

ALL DIMENSIONS ARE IN INCHES

THIS PRINT CONTAINS INFORMATION PROPRIETARY TO DIMPLEX THERMAL SOLUTIONS. MAY NOT BE DUPLICATED, REPRODUCED, OR SHARED IN ANY WAY WITHOUT THE EXPRESSED WRITTEN CONSENT OF DIMPLEX THERMAL SOLUTIONS.

CONFIDENTIAL AND PROPRIETARY

DATE	DESCRIPTION OF REVISION	APPROVED BY
02/16/10	ADDED WIRE DESCRIPTIONS S1 & S2	CJH <>
02/16/10	ADDED WIRE COLOR DIRECTIONS	CJH <>
01/22/10	UPDATED WIRE LOGIC	MAR <>

DESIGN BY: MAR
DATE: 01/07/09

DRAWN BY: MAR
PAGE 11 OF X

KALAMAZOO, MI
PH (800) 968-5665
WWW.DIMPLEXTHERMAL.COM

POWER METER LOGIC

ELECTRICAL

DRAWING NO. 443503

POWER METER

oooooooooooooooooooo

oooooooooooooooooooo

oooooooooooooooooooo

ELECTRICAL PANEL

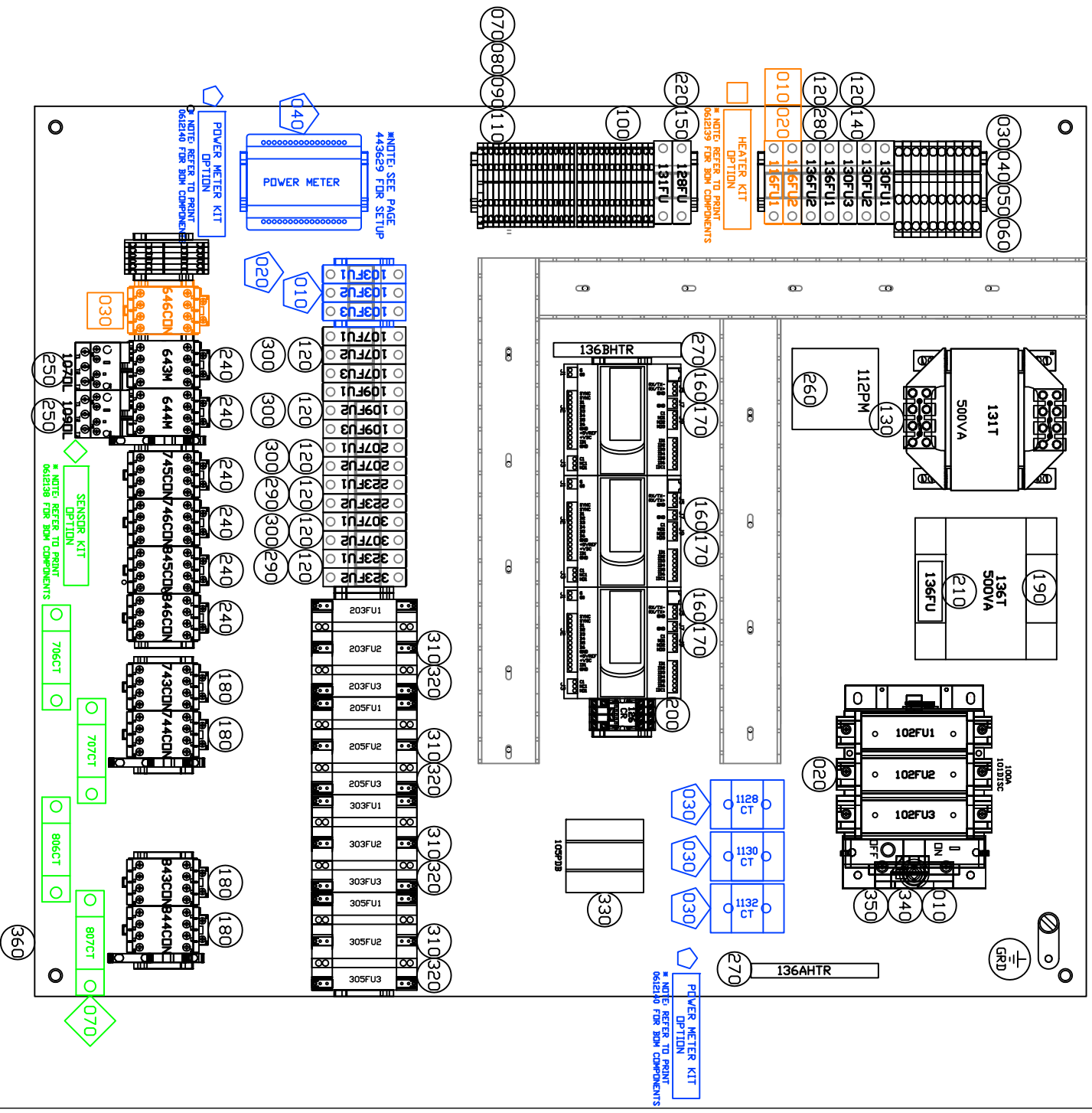

*NOTE: P266 VARIABLE SPEED CONTROLLERS ARE MOUNTED INSIDE MACHINE BEHIND ELECTRICAL ENCLOSURE.

*NOTE: MOUNT AMBIENT SENSOR INSIDE CHILLER UNIT BEHIND AIR FILTERS.

NO.	ID/DESCRIPTION	K.K. PART#	QTY	TYPE
*350	194R-R4 CONNECTING ROD IEC FITS 100-200 AMP DISCONNECT SHAFT	3114006	1.0	PC
*360	ALLEN BRADLEY WIR-2-5000-ENR BOX PANEL 42X36 SHEET 12 GA GALV 48 X 120 CHEMTEAT G-90 DRY 181 2 LBS/SHEET MODULAR PLUG 6 POSITION 150° CONDUCTS DEP. 2 POS 96-402 PLUG AN D ISO FACTORY W/ANC 6C EARTH LINE	0443803 9531200 4807789	1.0 44.0 1.0	PC PC PC
*370	ALLEN BRADLEY WIR-2-5000-ENR BOX PANEL 42X36 SHEET 12 GA GALV 48 X 120 CHEMTEAT G-90 DRY 181 2 LBS/SHEET MODULAR PLUG 6 POSITION 150° CONDUCTS DEP. 2 POS 96-402 PLUG AN D ISO FACTORY W/ANC 6C EARTH LINE	4807789	1.0	PC
*380	ALLEN BRADLEY WIR-2-5000-ENR BOX PANEL 42X36 SHEET 12 GA GALV 48 X 120 CHEMTEAT G-90 DRY 181 2 LBS/SHEET MODULAR PLUG 6 POSITION 150° CONDUCTS DEP. 2 POS 96-402 PLUG AN D ISO FACTORY W/ANC 6C EARTH LINE	4807797	1.0	PC
*390	ALLEN BRADLEY WIR-2-5000-ENR BOX PANEL 42X36 SHEET 12 GA GALV 48 X 120 CHEMTEAT G-90 DRY 181 2 LBS/SHEET MODULAR PLUG 6 POSITION 150° CONDUCTS DEP. 2 POS 96-402 PLUG AN D ISO FACTORY W/ANC 6C EARTH LINE	0905136	1.0	PC

FRONT VIEW OF ENCLOSURE

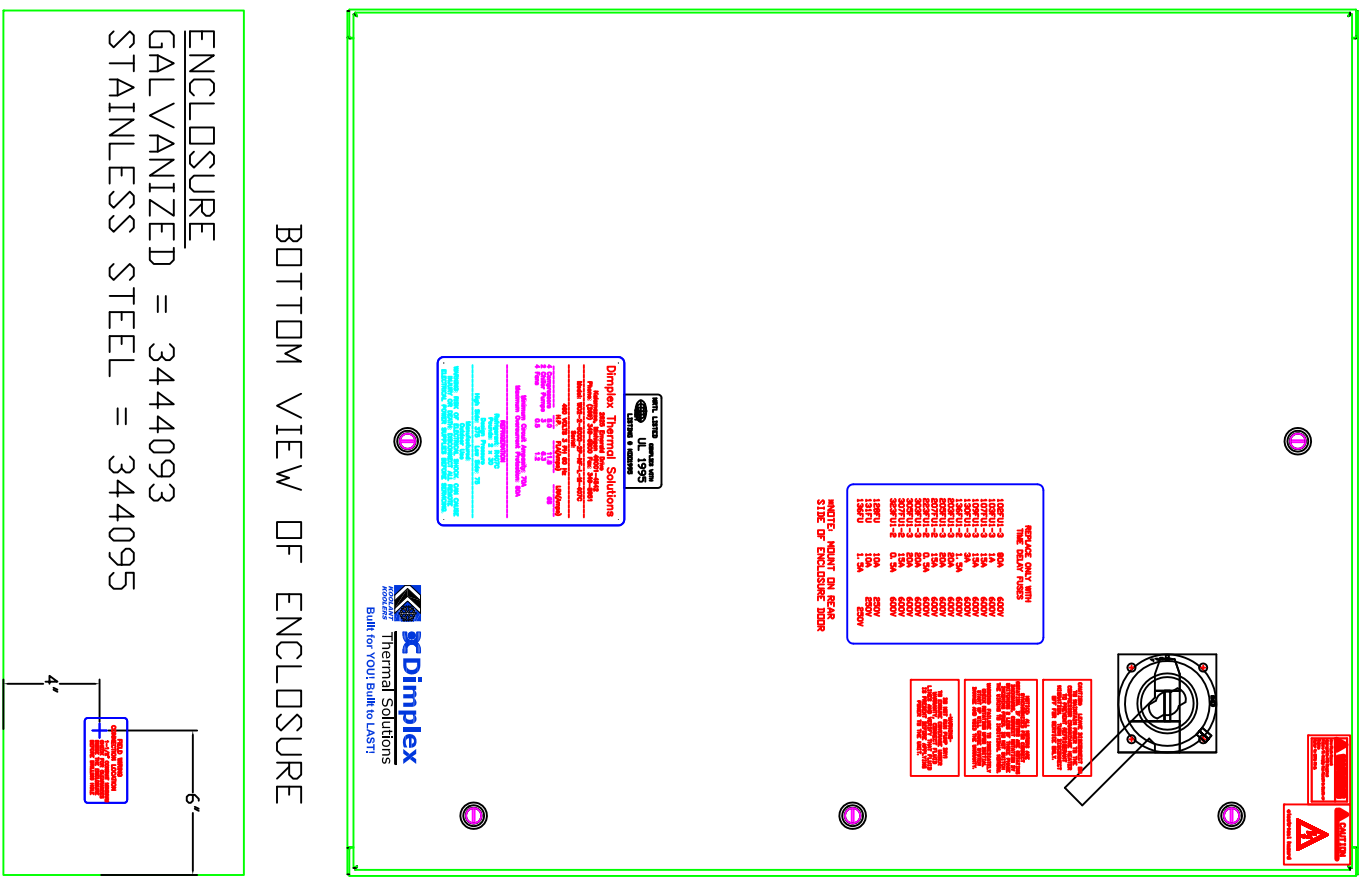

BOTTOM VIEW OF ENCLOSURE

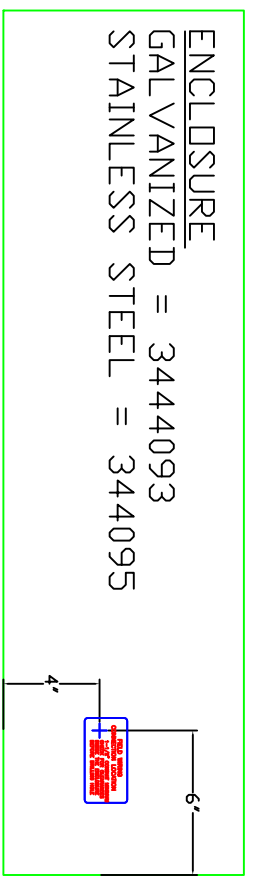

SHIP LOOSE
*PARTS NOT SHOWN ON DRAWING DETAIL

ALL DIMENSIONS ARE IN INCHES
THIS PRINT CONTAINS INFORMATION PROPRIETARY TO DIMPLEX THERMAL SOLUTIONS. MAY NOT BE DUPLICATED, REPRODUCED, OR SHARED IN ANY WAY WITHOUT THE EXPRESSED WRITTEN CONSENT OF DIMPLEX THERMAL SOLUTIONS.

NO.	ID/DESCRIPTION	K.K. PART#	QTY	TYPE
001	W02-2-5000-2P-NF-L-M-407C	0444849	1.0	ASSEM
010	194R-R4 CONNECTING ROD IEC FITS 100-200 AMP DISCONNECT SHAFT	3110005	1.0	PC
020	ALLEN BRADLEY WIR-2-5000-ENR BOX PANEL 42X36 SHEET 12 GA GALV 48 X 120 CHEMTEAT G-90 DRY 181 2 LBS/SHEET MODULAR PLUG 6 POSITION 150° CONDUCTS DEP. 2 POS 96-402 PLUG AN D ISO FACTORY W/ANC 6C EARTH LINE	3500919	3.0	PC
030	ALLEN BRADLEY WIR-2-5000-ENR BOX PANEL 42X36 SHEET 12 GA GALV 48 X 120 CHEMTEAT G-90 DRY 181 2 LBS/SHEET MODULAR PLUG 6 POSITION 150° CONDUCTS DEP. 2 POS 96-402 PLUG AN D ISO FACTORY W/ANC 6C EARTH LINE	3123003	10.0	PC
040	ALLEN BRADLEY WIR-2-5000-ENR BOX PANEL 42X36 SHEET 12 GA GALV 48 X 120 CHEMTEAT G-90 DRY 181 2 LBS/SHEET MODULAR PLUG 6 POSITION 150° CONDUCTS DEP. 2 POS 96-402 PLUG AN D ISO FACTORY W/ANC 6C EARTH LINE	3123085	4.0	PC
050	ALLEN BRADLEY WIR-2-5000-ENR BOX PANEL 42X36 SHEET 12 GA GALV 48 X 120 CHEMTEAT G-90 DRY 181 2 LBS/SHEET MODULAR PLUG 6 POSITION 150° CONDUCTS DEP. 2 POS 96-402 PLUG AN D ISO FACTORY W/ANC 6C EARTH LINE	3123087	11.0	PC
060	ALLEN BRADLEY WIR-2-5000-ENR BOX PANEL 42X36 SHEET 12 GA GALV 48 X 120 CHEMTEAT G-90 DRY 181 2 LBS/SHEET MODULAR PLUG 6 POSITION 150° CONDUCTS DEP. 2 POS 96-402 PLUG AN D ISO FACTORY W/ANC 6C EARTH LINE	3123178	5.0	PC
070	ALLEN BRADLEY WIR-2-5000-ENR BOX PANEL 42X36 SHEET 12 GA GALV 48 X 120 CHEMTEAT G-90 DRY 181 2 LBS/SHEET MODULAR PLUG 6 POSITION 150° CONDUCTS DEP. 2 POS 96-402 PLUG AN D ISO FACTORY W/ANC 6C EARTH LINE	3123021	35.0	PC
080	ALLEN BRADLEY WIR-2-5000-ENR BOX PANEL 42X36 SHEET 12 GA GALV 48 X 120 CHEMTEAT G-90 DRY 181 2 LBS/SHEET MODULAR PLUG 6 POSITION 150° CONDUCTS DEP. 2 POS 96-402 PLUG AN D ISO FACTORY W/ANC 6C EARTH LINE	3123086	2.0	PC
090	ALLEN BRADLEY WIR-2-5000-ENR BOX PANEL 42X36 SHEET 12 GA GALV 48 X 120 CHEMTEAT G-90 DRY 181 2 LBS/SHEET MODULAR PLUG 6 POSITION 150° CONDUCTS DEP. 2 POS 96-402 PLUG AN D ISO FACTORY W/ANC 6C EARTH LINE	3123017	3.0	PC
100	ALLEN BRADLEY WIR-2-5000-ENR BOX PANEL 42X36 SHEET 12 GA GALV 48 X 120 CHEMTEAT G-90 DRY 181 2 LBS/SHEET MODULAR PLUG 6 POSITION 150° CONDUCTS DEP. 2 POS 96-402 PLUG AN D ISO FACTORY W/ANC 6C EARTH LINE	3127100	2.0	PC
110	ALLEN BRADLEY WIR-2-5000-ENR BOX PANEL 42X36 SHEET 12 GA GALV 48 X 120 CHEMTEAT G-90 DRY 181 2 LBS/SHEET MODULAR PLUG 6 POSITION 150° CONDUCTS DEP. 2 POS 96-402 PLUG AN D ISO FACTORY W/ANC 6C EARTH LINE	3123095	0.5	PC
120	ALLEN BRADLEY WIR-2-5000-ENR BOX PANEL 42X36 SHEET 12 GA GALV 48 X 120 CHEMTEAT G-90 DRY 181 2 LBS/SHEET MODULAR PLUG 6 POSITION 150° CONDUCTS DEP. 2 POS 96-402 PLUG AN D ISO FACTORY W/ANC 6C EARTH LINE	3511203	19.0	PC
130	ALLEN BRADLEY WIR-2-5000-ENR BOX PANEL 42X36 SHEET 12 GA GALV 48 X 120 CHEMTEAT G-90 DRY 181 2 LBS/SHEET MODULAR PLUG 6 POSITION 150° CONDUCTS DEP. 2 POS 96-402 PLUG AN D ISO FACTORY W/ANC 6C EARTH LINE	3160015	1.0	PC
140	ALLEN BRADLEY WIR-2-5000-ENR BOX PANEL 42X36 SHEET 12 GA GALV 48 X 120 CHEMTEAT G-90 DRY 181 2 LBS/SHEET MODULAR PLUG 6 POSITION 150° CONDUCTS DEP. 2 POS 96-402 PLUG AN D ISO FACTORY W/ANC 6C EARTH LINE	3500970	3.0	PC
150	ALLEN BRADLEY WIR-2-5000-ENR BOX PANEL 42X36 SHEET 12 GA GALV 48 X 120 CHEMTEAT G-90 DRY 181 2 LBS/SHEET MODULAR PLUG 6 POSITION 150° CONDUCTS DEP. 2 POS 96-402 PLUG AN D ISO FACTORY W/ANC 6C EARTH LINE	3500091	2.0	PC
160	ALLEN BRADLEY WIR-2-5000-ENR BOX PANEL 42X36 SHEET 12 GA GALV 48 X 120 CHEMTEAT G-90 DRY 181 2 LBS/SHEET MODULAR PLUG 6 POSITION 150° CONDUCTS DEP. 2 POS 96-402 PLUG AN D ISO FACTORY W/ANC 6C EARTH LINE	4807776	3.0	PC
170	ALLEN BRADLEY WIR-2-5000-ENR BOX PANEL 42X36 SHEET 12 GA GALV 48 X 120 CHEMTEAT G-90 DRY 181 2 LBS/SHEET MODULAR PLUG 6 POSITION 150° CONDUCTS DEP. 2 POS 96-402 PLUG AN D ISO FACTORY W/ANC 6C EARTH LINE	4807777	3.0	PC
180	ALLEN BRADLEY WIR-2-5000-ENR BOX PANEL 42X36 SHEET 12 GA GALV 48 X 120 CHEMTEAT G-90 DRY 181 2 LBS/SHEET MODULAR PLUG 6 POSITION 150° CONDUCTS DEP. 2 POS 96-402 PLUG AN D ISO FACTORY W/ANC 6C EARTH LINE	3100401	4.0	PC
190	ALLEN BRADLEY WIR-2-5000-ENR BOX PANEL 42X36 SHEET 12 GA GALV 48 X 120 CHEMTEAT G-90 DRY 181 2 LBS/SHEET MODULAR PLUG 6 POSITION 150° CONDUCTS DEP. 2 POS 96-402 PLUG AN D ISO FACTORY W/ANC 6C EARTH LINE	3842502	1.0	PC
200	ALLEN BRADLEY WIR-2-5000-ENR BOX PANEL 42X36 SHEET 12 GA GALV 48 X 120 CHEMTEAT G-90 DRY 181 2 LBS/SHEET MODULAR PLUG 6 POSITION 150° CONDUCTS DEP. 2 POS 96-402 PLUG AN D ISO FACTORY W/ANC 6C EARTH LINE	0611215	1.0	ASSEM
001	ALLEN BRADLEY WIR-2-5000-ENR BOX PANEL 42X36 SHEET 12 GA GALV 48 X 120 CHEMTEAT G-90 DRY 181 2 LBS/SHEET MODULAR PLUG 6 POSITION 150° CONDUCTS DEP. 2 POS 96-402 PLUG AN D ISO FACTORY W/ANC 6C EARTH LINE	3805001	1.0	PC
002	ALLEN BRADLEY WIR-2-5000-ENR BOX PANEL 42X36 SHEET 12 GA GALV 48 X 120 CHEMTEAT G-90 DRY 181 2 LBS/SHEET MODULAR PLUG 6 POSITION 150° CONDUCTS DEP. 2 POS 96-402 PLUG AN D ISO FACTORY W/ANC 6C EARTH LINE	3805002	1.0	PC
210	ALLEN BRADLEY WIR-2-5000-ENR BOX PANEL 42X36 SHEET 12 GA GALV 48 X 120 CHEMTEAT G-90 DRY 181 2 LBS/SHEET MODULAR PLUG 6 POSITION 150° CONDUCTS DEP. 2 POS 96-402 PLUG AN D ISO FACTORY W/ANC 6C EARTH LINE	3500050	1.0	PC
220	ALLEN BRADLEY WIR-2-5000-ENR BOX PANEL 42X36 SHEET 12 GA GALV 48 X 120 CHEMTEAT G-90 DRY 181 2 LBS/SHEET MODULAR PLUG 6 POSITION 150° CONDUCTS DEP. 2 POS 96-402 PLUG AN D ISO FACTORY W/ANC 6C EARTH LINE	3510900	2.0	PC
230	ALLEN BRADLEY WIR-2-5000-ENR BOX PANEL 42X36 SHEET 12 GA GALV 48 X 120 CHEMTEAT G-90 DRY 181 2 LBS/SHEET MODULAR PLUG 6 POSITION 150° CONDUCTS DEP. 2 POS 96-402 PLUG AN D ISO FACTORY W/ANC 6C EARTH LINE	3646040	2.0	PC
240	ALLEN BRADLEY WIR-2-5000-ENR BOX PANEL 42X36 SHEET 12 GA GALV 48 X 120 CHEMTEAT G-90 DRY 181 2 LBS/SHEET MODULAR PLUG 6 POSITION 150° CONDUCTS DEP. 2 POS 96-402 PLUG AN D ISO FACTORY W/ANC 6C EARTH LINE	3100400	6.0	PC
250	ALLEN BRADLEY WIR-2-5000-ENR BOX PANEL 42X36 SHEET 12 GA GALV 48 X 120 CHEMTEAT G-90 DRY 181 2 LBS/SHEET MODULAR PLUG 6 POSITION 150° CONDUCTS DEP. 2 POS 96-402 PLUG AN D ISO FACTORY W/ANC 6C EARTH LINE	3103505	2.0	PC
260	ALLEN BRADLEY WIR-2-5000-ENR BOX PANEL 42X36 SHEET 12 GA GALV 48 X 120 CHEMTEAT G-90 DRY 181 2 LBS/SHEET MODULAR PLUG 6 POSITION 150° CONDUCTS DEP. 2 POS 96-402 PLUG AN D ISO FACTORY W/ANC 6C EARTH LINE	3813421	1.0	PC
270	ALLEN BRADLEY WIR-2-5000-ENR BOX PANEL 42X36 SHEET 12 GA GALV 48 X 120 CHEMTEAT G-90 DRY 181 2 LBS/SHEET MODULAR PLUG 6 POSITION 150° CONDUCTS DEP. 2 POS 96-402 PLUG AN D ISO FACTORY W/ANC 6C EARTH LINE	3835106	2.0	PC
280	ALLEN BRADLEY WIR-2-5000-ENR BOX PANEL 42X36 SHEET 12 GA GALV 48 X 120 CHEMTEAT G-90 DRY 181 2 LBS/SHEET MODULAR PLUG 6 POSITION 150° CONDUCTS DEP. 2 POS 96-402 PLUG AN D ISO FACTORY W/ANC 6C EARTH LINE	3500972	2.0	PC
290	ALLEN BRADLEY WIR-2-5000-ENR BOX PANEL 42X36 SHEET 12 GA GALV 48 X 120 CHEMTEAT G-90 DRY 181 2 LBS/SHEET MODULAR PLUG 6 POSITION 150° CONDUCTS DEP. 2 POS 96-402 PLUG AN D ISO FACTORY W/ANC 6C EARTH LINE	3500973	4.0	PC
300	ALLEN BRADLEY WIR-2-5000-ENR BOX PANEL 42X36 SHEET 12 GA GALV 48 X 120 CHEMTEAT G-90 DRY 181 2 LBS/SHEET MODULAR PLUG 6 POSITION 150° CONDUCTS DEP. 2 POS 96-402 PLUG AN D ISO FACTORY W/ANC 6C EARTH LINE	3500960	10.0	PC
310	ALLEN BRADLEY WIR-2-5000-ENR BOX PANEL 42X36 SHEET 12 GA GALV 48 X 120 CHEMTEAT G-90 DRY 181 2 LBS/SHEET MODULAR PLUG 6 POSITION 150° CONDUCTS DEP. 2 POS 96-402 PLUG AN D ISO FACTORY W/ANC 6C EARTH LINE	3501043	4.0	PC
320	ALLEN BRADLEY WIR-2-5000-ENR BOX PANEL 42X36 SHEET 12 GA GALV 48 X 120 CHEMTEAT G-90 DRY 181 2 LBS/SHEET MODULAR PLUG 6 POSITION 150° CONDUCTS DEP. 2 POS 96-402 PLUG AN D ISO FACTORY W/ANC 6C EARTH LINE	3500910	12.0	PC
330	ALLEN BRADLEY WIR-2-5000-ENR BOX PANEL 42X36 SHEET 12 GA GALV 48 X 120 CHEMTEAT G-90 DRY 181 2 LBS/SHEET MODULAR PLUG 6 POSITION 150° CONDUCTS DEP. 2 POS 96-402 PLUG AN D ISO FACTORY W/ANC 6C EARTH LINE	3899410	1.0	PC
340	ALLEN BRADLEY WIR-2-5000-ENR BOX PANEL 42X36 SHEET 12 GA GALV 48 X 120 CHEMTEAT G-90 DRY 181 2 LBS/SHEET MODULAR PLUG 6 POSITION 150° CONDUCTS DEP. 2 POS 96-402 PLUG AN D ISO FACTORY W/ANC 6C EARTH LINE	4801215	1.0	PC

DESIGN BY: MAR
DRAWN BY: MAR
DATE: 04/29/10
PAGE: 12 OF X
KALAMAZOO, MI
PH (800) 968-5665
WWW.DIMPLEXTHERMAL.COM
Thermal Solutions
SCHNEIDER
ELECTRICAL
DRAWING NO. 444849

ELECTRICAL PANEL

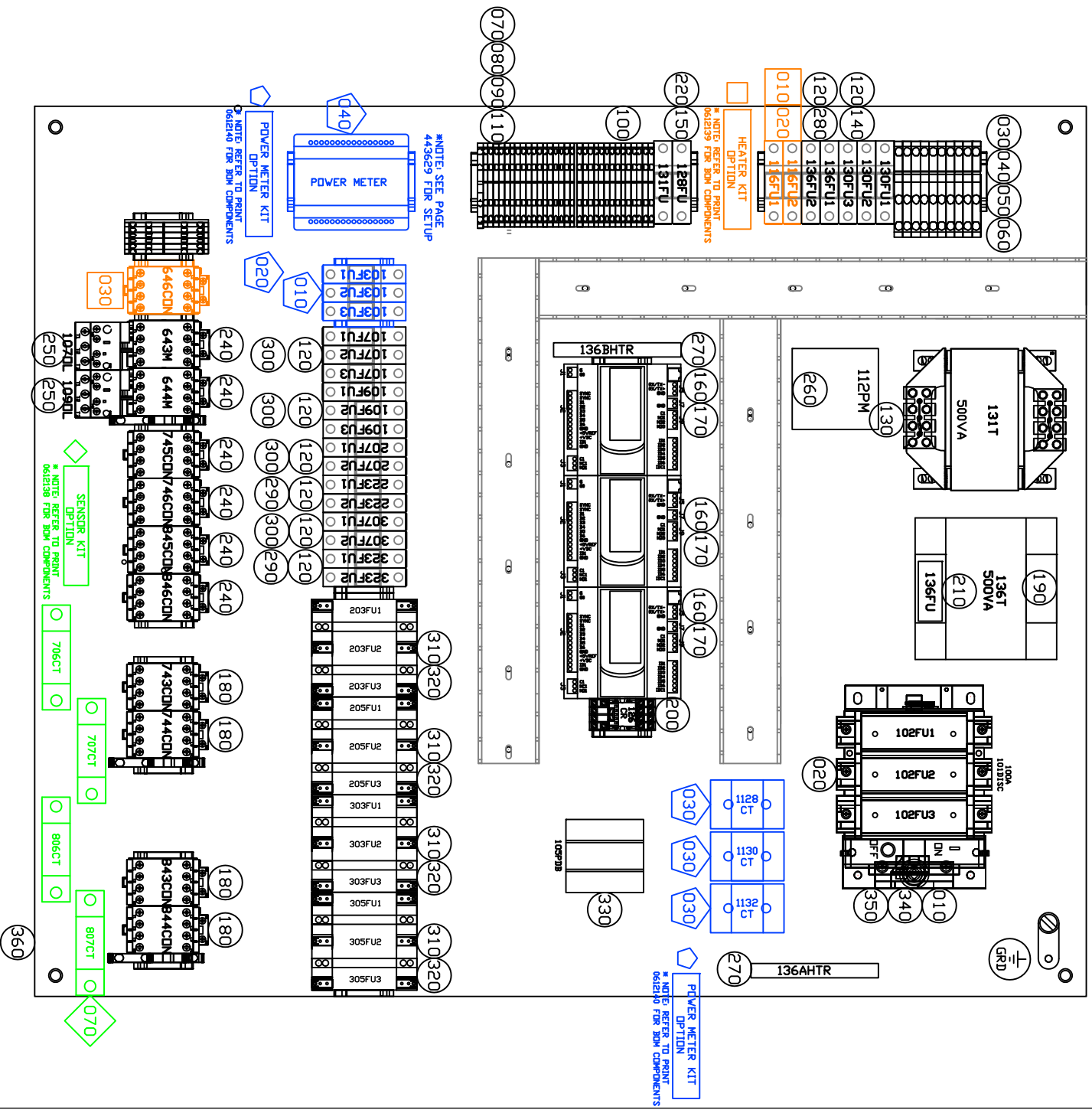

*NOTE: P266 VARIABLE SPEED CONTROLLERS ARE MOUNTED INSIDE MACHINE BEHIND ELECTRICAL ENCLOSURE.

*NOTE: MOUNT AMBIENT SENSOR INSIDE CHILLER UNIT BEHIND AIR FILTERS.

NO.	ID/DESCRIPTION	K.K. PART#	QTY	TYPE
*350	194R-R4 CONNECTING ROD IEC FITS 100-200 AMP DISCONNECT SHAFT	3114006	1.0	PC
*360	ALLEN BRADLEY WIR-2-5000-ENR BOX PANEL 42X36 SHEET 12 GA GALV 48 X 120 CHEMTEAT G-90 DRY 181 2 LBS/SHEET	0443803	1.0	ASSEM
*010	MODULAR PLUG, 6 POSITION, 150° CONDUCTS DR. 2 PCS 96-402 BUZ AN	9531200	44.0	PC
*370	MODULAR VALVE RAIL #09051366	4807789	1.0	PC
*380	CABEL LOGIC PRODRAM #09051366	4807797	1.0	PC
*390	MediCal Line Chiller 1-4 Compress or's, 1-2 Process Pumps 1100L SQFTW	0905136	1.0	PC

FRONT VIEW OF ENCLOSURE

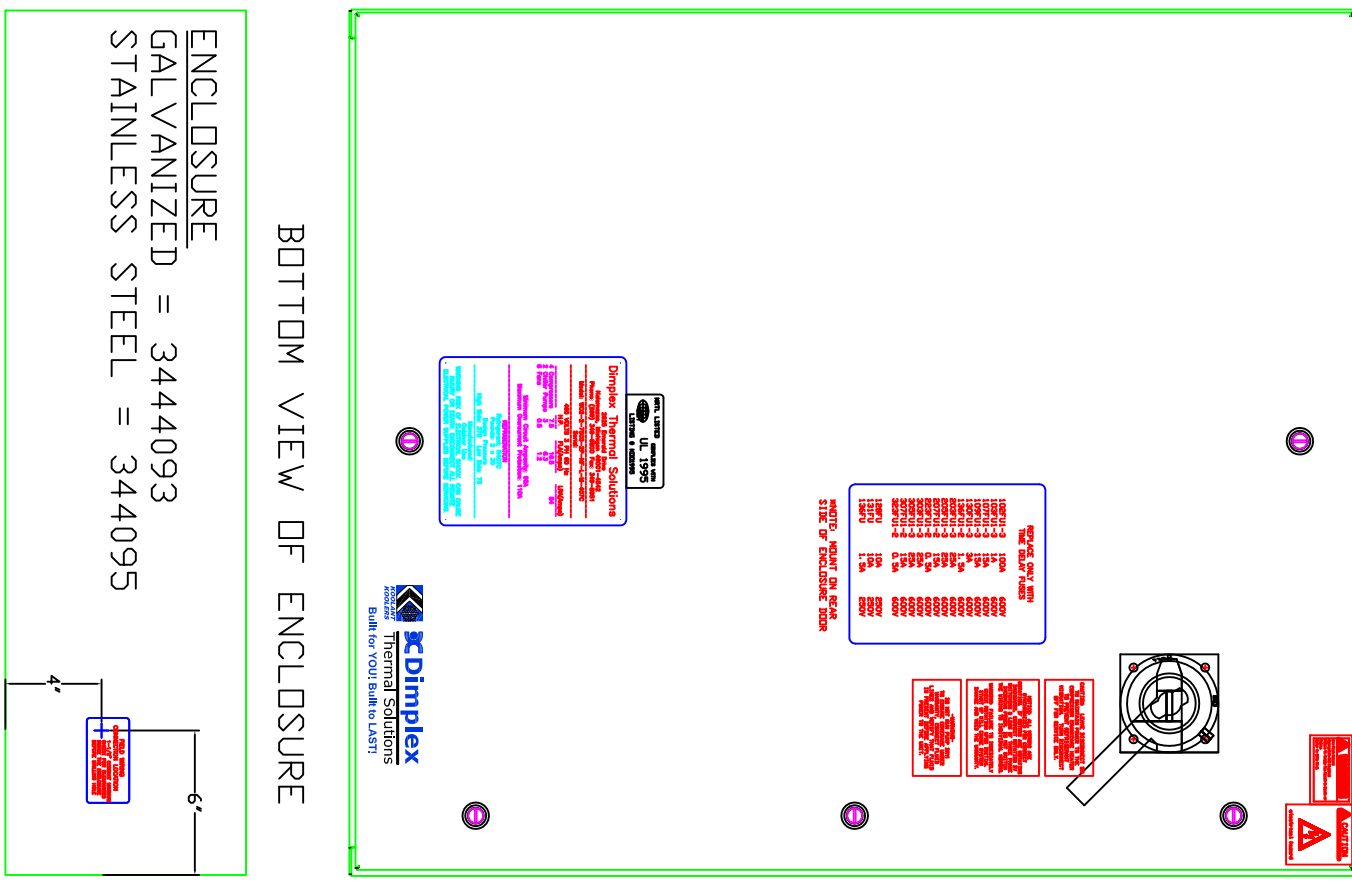

BOTTOM VIEW OF ENCLOSURE

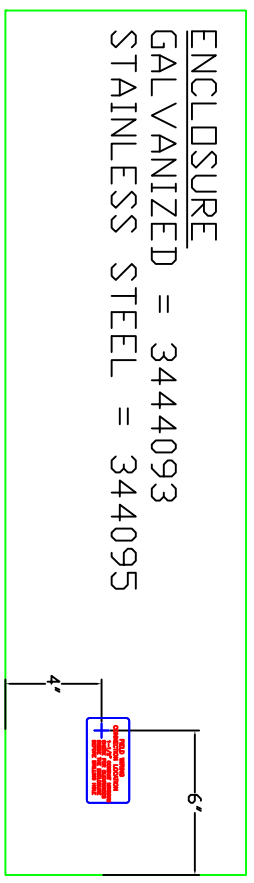

ENCLOSURE GALVANIZED = 3444093 STAINLESS STEEL = 344095

SHIP LOOSE * PARTS NOT SHOWN ON DRAWING DETAIL

ALL DIMENSIONS ARE IN INCHES

THIS PRINT CONTAINS INFORMATION PROPRIETARY TO DIMPLEX THERMAL SOLUTIONS. MAY NOT BE DUPLICATED, REPRODUCED, OR SHARED IN ANY WAY WITHOUT THE EXPRESSED WRITTEN CONSENT OF DIMPLEX THERMAL SOLUTIONS.

CONFIDENTIAL AND PROPRIETARY

NO.	ID/DESCRIPTION	K.K. PART#	QTY	TYPE
001	W02-15000-2P-NF-L-M-407C	0444795	1.0	PC
010	194R-N100P34ER3 DISCONNECT 100A 70 AMP TO 100 AMP AJT FUSES WITH S HAFT FOR UP TO 10" DEEP BOX FOR DEF PER BRX USE 3114006, COMES WITH LUGS ALLEN BRADLEY	3110005	1.0	PC
020	ALLEN BRADLEY 4JT100 DR LP1100 FUSE	3500921	3.0	PC
030	ALLEN BRADLEY 149S-15T TERMINAL BLOCK (50 AMP)	3123003	10.0	PC
040	ALLEN BRADLEY 149S-15T END BARRIER (50 AMP)	3123085	4.0	PC
050	ALLEN BRADLEY 149S-15S END ANCHOR (20/50 AMP)	3123087	11.0	PC
060	ALLEN BRADLEY 149E-LG61 GROUND BLOCK (50 AMP) 1 CIRCUIT, 2 CONNECTIONS, GREEN/YE LUDJ	3123178	5.0	PC
070	ALLEN BRADLEY 149E-3Q TERMINAL BLOCK (20 AMP)	3123021	35.0	PC
080	ALLEN BRADLEY 149E-EB3Q END BARRIER (20 AMP)	3123086	2.0	PC
090	ALLEN BRADLEY 149E-LG3Q GROUNDING BLOCK (20 AMP)	3123017	3.0	PC
100	ALLEN BRADLEY 199-DRT MOUNTING RAIL	3127100	2.0	PC
110	SPC/BOX 1 METER LONG ALLEN BRADLEY 149E-CJK910 JUMPER (20 AMP)	3123095	0.5	PC
120	ALLEN BRADLEY CHCID FUSE HOLDER 30A, CC CLASS	3511203	19.0	PC
130	1497-G-BAK-O-N TRANSFORMER 500VA	3160015	1.0	PC
140	ALLEN BRADLEY 149S-15S END ANCHOR (20/50 AMP)	3500970	3.0	PC
150	ALLEN BRADLEY 149S-15S END ANCHOR (20/50 AMP)	3500091	2.0	PC
160	ALLEN BRADLEY 149S-15S END ANCHOR (20/50 AMP)	4807776	3.0	PC
170	ALLEN BRADLEY 149S-15S END ANCHOR (20/50 AMP)	4807777	3.0	PC
180	ALLEN BRADLEY 149S-15S END ANCHOR (20/50 AMP)	3100403	4.0	PC
190	ALLEN BRADLEY 149S-15S END ANCHOR (20/50 AMP)	3842502	1.0	PC
200	ALLEN BRADLEY 149S-15S END ANCHOR (20/50 AMP)	0611215	1.0	ASSEM
001	ALLEN BRADLEY 149S-15S END ANCHOR (20/50 AMP)	3805001	1.0	PC
002	ALLEN BRADLEY 149S-15S END ANCHOR (20/50 AMP)	3805002	1.0	PC
210	ALLEN BRADLEY 149S-15S END ANCHOR (20/50 AMP)	3500050	1.0	PC
220	ALLEN BRADLEY 149S-15S END ANCHOR (20/50 AMP)	3510900	2.0	PC
230	ALLEN BRADLEY 149S-15S END ANCHOR (20/50 AMP)	3646040	2.0	PC
240	ALLEN BRADLEY 149S-15S END ANCHOR (20/50 AMP)	3100400	6.0	PC
250	ALLEN BRADLEY 149S-15S END ANCHOR (20/50 AMP)	3103505	2.0	PC
260	ALLEN BRADLEY 149S-15S END ANCHOR (20/50 AMP)	3813419	1.0	PC
270	ALLEN BRADLEY 149S-15S END ANCHOR (20/50 AMP)	3835106	2.0	PC
280	ALLEN BRADLEY 149S-15S END ANCHOR (20/50 AMP)	3500970	2.0	PC
290	ALLEN BRADLEY 149S-15S END ANCHOR (20/50 AMP)	3500973	4.0	PC
300	ALLEN BRADLEY 149S-15S END ANCHOR (20/50 AMP)	3500960	10.0	PC
310	ALLEN BRADLEY 149S-15S END ANCHOR (20/50 AMP)	3501043	4.0	PC
320	ALLEN BRADLEY 149S-15S END ANCHOR (20/50 AMP)	3500911	12.0	PC
330	ALLEN BRADLEY 149S-15S END ANCHOR (20/50 AMP)	3899410	1.0	PC
340	ALLEN BRADLEY 149S-15S END ANCHOR (20/50 AMP)	4801215	1.0	PC

DESIGN BY: MAR
DRAWN BY: MAR

DATE: 04/26/10
PAGE: 12 OF X

W02-2-7500-2P-L-M-407C

ELECTRICAL

DRAWING NO: 444795