

Koolant Coolers J Series

Portable Chiller



USER MANUAL

Register Your Chiller

To register your chiller, go to <http://www.dimplexthermal.com/service/register-chiller-location/>

ATTENTION

This manual provides the user, installer and maintenance technician the technical information for installation, operation and routine maintenance to ensure long life of the J Series chiller.

While some models may have different options, this manual is written with general guidelines and specifications. Refer to your specific model drawings, which shipped with the unit, for information about what features the chiller has.

When contacting the factory for service or replacement parts, refer to the chiller's serial number and model number. These can be found on the data label on the chiller or on the data pack information that shipped with the unit.

Information Subject to Change

While every effort has been made to ensure the accuracy and completeness of the information presented in this document, Dimplex Thermal Solutions assumes no responsibility and disclaims all liability for damages resulting from use of this information or for any errors or omissions.

TABLE OF CONTENTS

| | |
|--|-----------|
| IMPORTANT SAFETY INSTRUCTIONS | 1 |
| General Safety Guidelines | 2 |
| 1.0 INTRODUCTION | 3 |
| 1.1 Product Summary | 4 |
| 1.2 General Operating Conditions | 4 |
| 1.3 Specifications | 5 |
| 1.4 Component Location | 6 |
| 2.0 INSTALLATION GUIDELINES | 9 |
| 2.1 Location Considerations | 9 |
| 2.2 Unpacking and Positioning | 10 |
| 3.0 INSTALLATION | 11 |
| 3.1 Checking for Shipping Damage | 11 |
| 3.2 Packaging Material—All Models | 11 |
| 3.3 Moving the J Series | 11 |
| 3.3.1 Removing the Chiller from the Shipping Skid | 12 |
| 3.4 Connections and System Setup | 13 |
| 3.4.1 Piping Connections | 14 |
| 3.5 Process Coolant—Water or Water/Glycol | 15 |
| 3.6 Glycol | 16 |
| 3.7 Electrical Connections—Input Power | 17 |
| 3.7.1 Electrical Connections—Optional Interlock Wiring | 18 |
| 3.8 Check Pump Motor Rotation (Three-Phase Units Only) | 19 |
| 4.0 CHECKLIST FOR COMPLETED INSTALLATION | 20 |
| 4.1 Moving and Placing Equipment | 20 |
| 4.2 Electrical | 20 |
| 4.3 Piping | 20 |
| 5.0 OPERATION | 21 |
| 5.1 Initial Startup | 21 |
| 5.2 Chiller Shutdown | 21 |
| 5.3 Basic Operation | 21 |
| 5.3.1 Changing the Setpoint | 21 |
| 6.0 TROUBLESHOOTING | 22 |
| 7.0 MAINTENANCE | 25 |
| 7.1 Cleaning External Electrical Parts | 25 |
| 7.2 Cleaning Contaminated Refrigerant System | 25 |
| 7.3 Maintenance Guidelines | 25 |

| | | |
|---|---|-----------|
| 7.4 | Suggested Maintenance Checklist | 26 |
| 7.4.1 | Maintenance Checklist—Weekly | 26 |
| 7.4.2 | Maintenance Checklist—Monthly | 26 |
| 7.4.3 | Maintenance Checklist—Every Three Months | 26 |
| 7.4.4 | Electric Panel | 26 |
| 7.4.5 | Filter | 27 |
| 8.0 | DISPOSAL AND RECYCLING INFORMATION | 28 |
| 8.1 | Recycling Methods | 28 |
| APPENDIX A - SPARE PARTS | | 29 |
| APPENDIX B - SERVICE | | 30 |
| B.1 | Startup Assistance Services | 30 |
| B.2 | Planned Maintenance Services | 31 |
| B.3 | Online Chiller Registration | 31 |
| B.4 | DTS Factory Refurbish Program | 31 |
| B.5 | Service Evaluations and Repairs | 32 |
| APPENDIX C - WARRANTY | | 33 |

Figures

| | | |
|-----------|---|----|
| Figure 1 | J Series Chiller, Typical | 3 |
| Figure 2 | Typical Features, Front | 6 |
| Figure 3 | Typical Features, Rear | 7 |
| Figure 4 | Typical Components-Internal | 8 |
| Figure 5 | Installation Clearances | 9 |
| Figure 6 | Unpacking the J Series | 12 |
| Figure 7 | Move the J Series Chiller with a Forklift | 13 |
| Figure 8 | Electrical and Piping Locations—Rear of Chiller | 14 |
| Figure 9 | Typical Piping Connections | 15 |
| Figure 10 | Interlock Jumper Location | 18 |
| Figure 11 | Motor Rotation Indicator | 19 |
| Figure 12 | Filter Replacement | 27 |

Tables

| | | |
|---------|---|----|
| Table 1 | Electrical Data, Cooling Capacity, Flow Pressure ¹ | 5 |
| Table 2 | Dimensions and Weights | 6 |
| Table 3 | Water/glycol proportions, freezing point | 16 |
| Table 4 | IR33 Troubleshooting Guide | 22 |
| Table 5 | Troubleshooting | 23 |
| Table 6 | Replacement Parts Kits | 29 |

IMPORTANT SAFETY INSTRUCTIONS

This manual contains important safety instructions that should be followed during the installation and maintenance of the Koolant Coolers J Series chillers. Read this manual thoroughly before attempting to install or operate this unit. Failure to follow the instructions in this document may damage the equipment, cause hazardous conditions and void the warranty.

Adhere to all warnings, cautions and safety instructions on the unit and in this manual when installing, operating or maintaining the unit. Follow all operating and user instructions.

WARNING

This unit may present arc flash and electric shock hazards that could cause injury and death. Open all local electric power disconnect switches and wear protective equipment before working within any J Series cabinet.

Customer must provide earth ground to the unit, per NEC, CEC and local codes, as applicable.

The controller does not isolate power from the unit, even in the Unit Off mode. The only way to ensure that there is no voltage inside the unit is to install and open a remote disconnect switch.

Only properly trained and qualified personnel should move, install, operate or service this equipment.

Follow all local codes.

WARNING

The J Series has high-speed moving parts, including a fan and compressor motor. Contact with these parts can cause injury and death. Open all electric power disconnect switches before working in the unit.

Do not operate this unit with any cabinet panels removed.

WARNING

High-pressure gas cylinders present a risk of explosive rupture if improperly handled or stored. A rupturing gas cylinder can cause property damage, injury and death.

The manufacturer's instructions and local safety regulations must be observed when handling and storing high pressure gas cylinders.

CAUTION

Water and other fluids used in this equipment may leak or be spilled, causing a slip, trip or fall hazard that could cause injury. Hoses are routed throughout parts of the equipment and on the floor during use, which also may pose a hazard.

To reduce the likelihood of a slip, trip or fall hazard, the user must clean up any spilled water around the equipment in a timely manner and route hoses in a manner that will reduce or eliminate the possibility of slipping, tripping and falling.

CAUTION

Some components become extremely hot during operation. Allow sufficient time for them to cool before working within the unit. Wear protective gloves and arm protection when working on or near hot components.

NOTICE

Cooling coils, heat exchangers and piping systems that are connected to open cooling towers or other open water/glycol systems are at high risk of freezing and premature corrosion. Fluids in these systems must contain the proper antifreeze and inhibitors to prevent freezing.

Read and follow individual unit installation instructions for precautions regarding fluid system design, material selection and use of field-provided devices. Never use automotive antifreeze in a J Series chiller.



NOTICE

Improper installation, application and service practices can result in water leakage from the unit, causing damage to property.

Do not locate the unit directly above any equipment that could sustain water damage.



NOTICE

Improper storage can cause damage to the unit.

Keep the unit upright, indoors and protected from dampness, freezing temperatures and contact damage.



NOTICE

Using the wrong type of refrigerant or mixing refrigerant types can damage the unit and degrade performance.

J Series chillers use R134a as refrigerant. Other types of refrigerant gases must not be substituted for R134a or mixed with R134a.

General Safety Guidelines

- Do not weld or carry out any operation that produces heat near a system that contains oil or flammable liquids. Systems that may contain oil or flammable liquids must be drained and cleaned before being exposed to a procedure that involves a heat source.
Exercise caution when welding or making any repair that generates heat, flames or sparks. Protect adjacent areas with non-flammable material.
- Never weld or modify any vessel that may be put under pressure.
- Inspect and clean heat transfer surfaces, particularly condenser fins, regularly to prevent high working temperature and pressure.
- Do not allow damage to safety valves and other pressure relief devices.
- Never use an open flame to inspect any part of the machine.
- Reattach all guards after finishing repairs or maintenance work. Never leave tools, parts or cleaning supplies on or in the chiller.
- Clean the J Series chiller only with non-flammable cleaners. If a cleaner that releases toxic vapors or strong fumes is used for cleaning, take precautions to prevent any accumulation of the toxic vapors.

Spare Parts Availability

The Dimplex Thermal Solutions Parts Department offers replacement parts for any component of your Koolant Koolers, Schreiber and Riedel brand chillers. Some parts, such as filters and fuses, are offered singly, but DTS also offers replacement parts kits (see **Table 6**).

Most parts are available with next-day shipping (if order is placed by 3p.m. EST). Parts may be purchased individually, such as filters, glycol and fuses, but DTS offers spare replacement parts kits (see **Table 6**). To order parts, call 1-800-968-5665 or visit www.dimplexthermal.com/parts

1.0 INTRODUCTION

J Series chillers by Dimplex Thermal Solutions are portable, closed-loop systems, designed to cool a liquid flow. Featuring 1/8 to 2 ton capacity (2,100-24,000 BTU/hr), the J Series air cooled chiller is ideal for indoor plug-and-play applications. The brazed plate evaporator offers efficient cooling for many processes, including clean oil applications, welding and machine tools.

Included on the J Series is a high-quality digital controller that provides precise temperature control. The sloped face makes it easy to view the controller and provides surface to mount additional gauges and controls.

Connecting the J Series is easy with terminal strips for customer power and interlocking connections for easy field wiring. All fluid connections are on the same side of the unit. With portable casters and closed tank design, the J Series can be backed up to a piece of equipment and still have full view of the controller and fluid level gauge.

The J Series chillers are available in water and water/glycol models.

The J Series's operating temperature range is 50-95°F (10-35°C). The J Series output is factory-set to 65° (18°C). This can be changed $\pm 10^{\circ}\text{F}$ ($\pm 7^{\circ}\text{C}$).

Figure 1 J Series Chiller, Typical



1.1 Product Summary

J Series Chillers offer the features and options below.

| Standard Features | Options |
|--|---|
| Air-Cooled, Closed Tank | Mechanical Auto Makeup (Refills Coolant Tank) |
| Capacity from 2,100 to 24,000 BTU/hr | Pressure Relief Bypass Valve |
| Water or Water/Glycol (70/30) | Various Voltage and Flow/Pressure Options |
| R134a Refrigerant | Motorized Hot Gas Bypass Valve |
| Stainless Steel Cabinet | Low Coolant Flow Alarm (External Connection) |
| Indoor Use Only | Internal Low Coolant Level Alarm |
| Fluid Setpoint 50°F-80°F | |
| Operating Temperature Range: 50-95°F (10-35°C) | |
| Temperature Stability ±3°F (1.5°C) | |
| UL 1995 Certification | |

1.2 General Operating Conditions

Temperature—This equipment will operate correctly in its intended ambient, between 50 and 95°F (10 and 35°C). Operating in temperatures outside the 65°F (18°C) setpoint will affect the cooling capacity. Contact the factory for assistance if operating at temperatures outside the setpoint is necessary.

Relative Humidity—This equipment will operate correctly within an environment at 90% maximum relative humidity at the maximum recommended operating temperatures, 95°F (35°C). The user must take measures to prevent the harmful effects of condensation.

Elevation—This equipment will operate correctly at the rated ambient up to 3280 ft. (1000m) above mean sea level. Operation at higher elevations is possible at derated ambient temperatures. Contact the factory for details.

Transportation and Storage—This equipment has been protected against damage in transportation and by storage at temperatures of -13°F to 131°F (-25°C to 55°C) and for short periods up to 158°F (70°C). It has been packaged to prevent damage from the effects of normal humidity, vibration and shock.

1.3 Specifications

The data in Table 1 is for reference only; refer to the data pack that shipped with your model.

Table 1 Electrical Data, Cooling Capacity, Flow Pressure ¹

| Model # | Input Power V/Ph/Hz | FLA | Cooling Capacity BTU/h (kW) | Flow/Pressure GPM @ PSI (L/m @ bar) | Fill Capacity gal (l) | Compressor hp (kW) | Pump hp (kW) |
|------------|------------------------|------|-----------------------------------|---|--------------------------|-----------------------|-----------------|
| JHI-180-M | 115/1/60 | 11.7 | 2,100 (0.6) | 2 GPM @ 50 psi (8 L/m @ 3.4 Bar) | 5 (18.93) | 0.25 (0.2) | 1/3 (0.2) |
| JHI-500-M | 115/1/60 | 15.5 | 4,300 (1.3) | 4 GPM @ 50 psi (15 L/m @ 3.4 Bar) | 5 (18.93) | 0.5 (0.4) | 1/3 (0.2) |
| | 230/1/60 | 9.3 | 4,300 (1.3) | | 5 (18.93) | 0.5 (0.4) | 1/3 (0.2) |
| | 230/1/60 | 9.5 | 4,300 (1.3) | | 5 (18.93) | 0.5 (0.4) | 1/3 (0.2) |
| JHI-1000-M | 230/1/60 | 17 | 12,000 (3.5) | 4 GPM @ 50 psi (15 L/m @ 3.4 Bar) | 10 (37.85) | 1.0 (0.8) | 1/3 (0.2) |
| | 230/1/60 | 21 | 12,000 (3.5) | 10 GPM @ 35 psi (38 L/m @ 2.4 Bar) | 10 (37.85) | 1.0 (0.8) | 1.0 (0.8) |
| | 230/3/60 | 12 | 12,000 (3.5) | 4 GPM @ 50 psi (15 L/m @ 3.4 Bar) | 10 (37.85) | 1.5 (1.1) | 1/2 (0.4) |
| | 230/3/60 | 12.6 | 12,000 (3.5) | 10 GPM @ 35 psi (38 L/m @ 2.4 Bar) | 10 (37.85) | 1.0 (0.8) | 1.0 (0.8) |
| | 460/3/60 | 6.1 | 12,000 (3.5) | 4 GPM @ 50 psi (15 L/m @ 3.4 Bar) | 10 (37.85) | 1.0 (0.8) | 1/2 (0.4) |
| | 460/3/60 | 6.7 | 12,000 (3.5) | 10 GPM @ 35 psi (38 L/m @ 2.4 Bar) | 10 (37.85) | 1.0 (0.8) | 1.0 (0.8) |
| | 460/3/60 | 6.8 | 12,000 (3.5) | | 10 (37.85) | 1.0 (0.8) | 1.0 (0.8) |
| JHI-1500-M | 230/1/60 | 24 | 18,000 (5.3) | 4 GPM @ 50 psi (15 L/m @ 3.4 Bar) | 10 (37.85) | 1.5 (1.1) | 1/3 (0.2) |
| | 230/3/60 | 12 | 18,000 (5.3) | 4 GPM @ 50 psi (15 L/m @ 3.4 Bar) | 10 (37.85) | 1.5 (1.1) | 1/2 (0.4) |
| | 230/3/60 | 17 | 18,000 (5.3) | | 10 (37.85) | 1.5 (1.1) | 1/2 (0.4) |
| | 230/3/60 | 18 | 18,000 (5.3) | 10 GPM @ 35 psi (38 L/m @ 2.4 Bar) | 10 (37.85) | 1.5 (1.1) | 1.0 (0.8) |
| | 460/3/60 | 7.5 | 18,000 (5.3) | 4 GPM @ 50 psi (15 L/m @ 3.4 Bar) | 10 (37.85) | 1.5 (1.1) | 1/2 (0.4) |
| | 460/3/60 | 8.1 | 18,000 (5.3) | 10 GPM @ 35 psi (38 L/m @ 2.4 Bar) | 10 (37.85) | 1.5 (1.1) | 1.0 (0.8) |
| JHI-2000-M | 230/1/60 | 34 | 24,000 (7.0) | 10 GPM @ 35 psi (38 L/m @ 2.4 Bar) | 10 (37.85) | 3.5 (2.6) | 1.0 (0.8) |
| | 230/3/60 | 22 | 24,000 (7.0) | | 10 (37.85) | 2.0 (1.5) | 1.0 (0.8) |
| | 230/3/60 | 30 | 24,000 (7.0) | 10 GPM @ 35 psi (38 L/m @ 2.4 Bar) | 10 (37.85) | 2.0 (1.5) | 2.0 (1.5) |
| | 460/3/60 | 10 | 24,000 (7.0) | | 10 (37.85) | 3.0 (2.2) | 1.0 (0.8) |
| | 460/3/60 | 14 | 24,000 (7.0) | | 10 (37.85) | 3.0 (2.2) | 2.0 (1.5) |

1. Specifications do not include all possible options that may cause your chiller to vary from this data.
2. AMU: Auto makeup valve in coolant reservoir
3. PRBV: Pressure Relief Bypass Valve
4. AMU: Auto makeup valve in coolant reservoir
5. PRBV: Pressure Relief Bypass Valve

Table 2 Dimensions and Weights

| Model # | Dimensions in. (mm) | Pump hp (kW) | Weight, lb. (kg) | |
|------------|---|--------------|------------------|-------------|
| | | | Net | Shipping |
| JHI-180-M | 21-1/8 x 26-1/2 x 28-5/8 (536.6 x 673.1 x 650.8) | 1/3 (0.25) | 290 (131.5) | 245 (111.1) |
| JHI-500-M | 21-1/8 x 26-1/2 x 28-5/8 (536.6 x 673.1 x 650.8) | 1/3 (0.25) | 345 (156.4) | 310 (140.6) |
| JHI-1000-M | 25-1/8 x 35-1/2 x 33-3/8 (638.2 x 901.7 x 847.7) | 1/3 (0.25) | 530 (240.3) | 450 (204.1) |
| JHI-1500-M | 25-1/8 x 35-1/2 x 33-3/8 (638.2 x 901.7 x 847.7) | 1/3 (0.25) | 570 (258.5) | 490 (222.3) |
| JHI-2000-M | 31-5/8 x 33-1/2 x 35-5/8 (803.3 x 850.9 x 904.8) | 2 (1.5) | 645 (292.5) | 630 (285.8) |

1.4 Component Location

Front-mounted controls make the J Series chiller simple to use. Most models install with just power connections, external monitoring connections and piping. To ease maintenance, the filter, strainer and coolant reservoir drain are accessible by removing a panel from the stainless steel cabinet.

! NOTICE

Risk of unit moving during installation, operation and service. Can cause damage to unit and other equipment.

The casters must be locked whenever the J Series chiller is not being moved. The casters must be locked before the J Series chiller is started and must remain locked while it is operating. Vibration during chiller operation could cause the chiller to move, which could cause kinked hoses and disconnected power supply.

Figure 2 Typical Features, Front

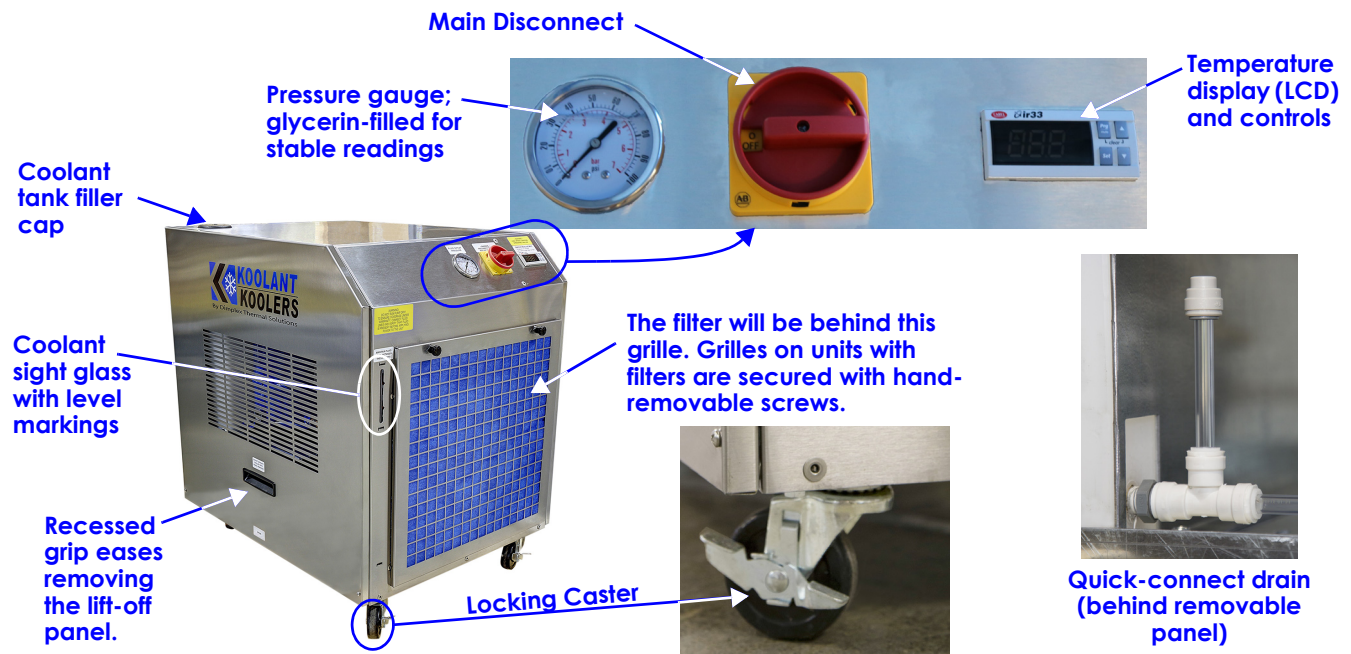

Figure 3 Typical Features, Rear

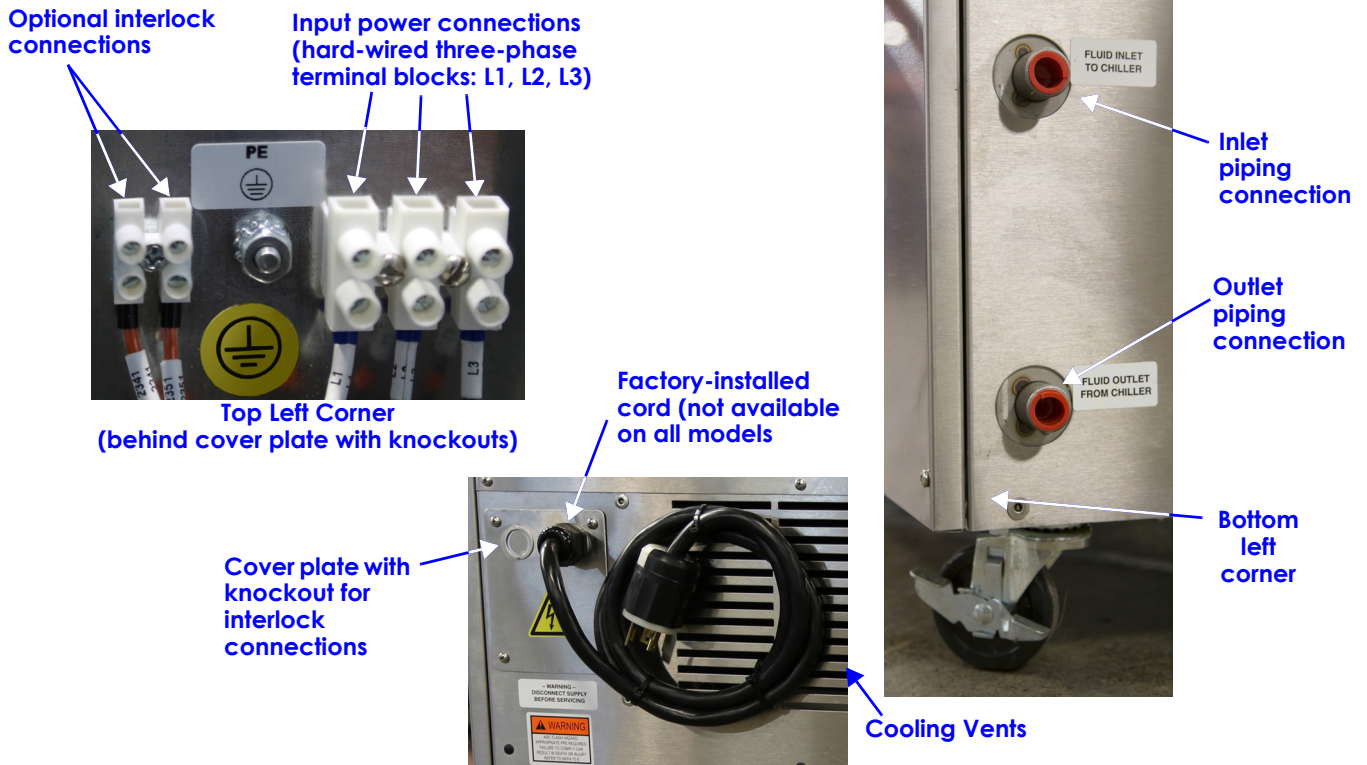
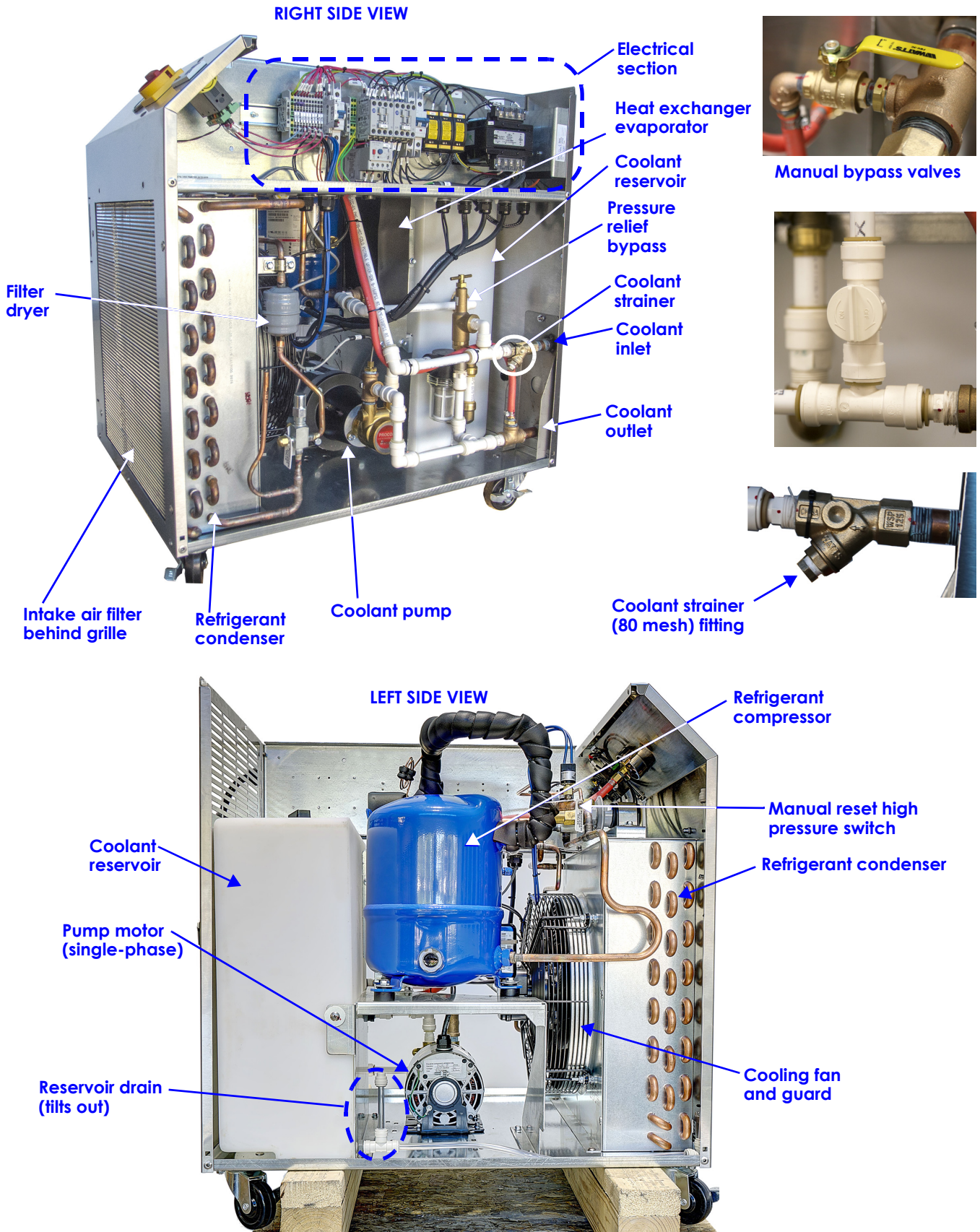

Figure 4 Typical Components-Internal



2.0 INSTALLATION GUIDELINES



WARNING

This unit may present arc flash and electric shock hazards that could cause injury and death. Open all local electric power disconnect switches and wear protective equipment before working within any J Series cabinet.

Customer must provide earth ground to the unit, per NEC, CEC and local codes, as applicable.

The controller does not isolate power from the unit, even in the Unit Off mode. To ensure that there is no voltage inside the unit, is to turn off the chiller with the disconnect switch.

Only properly trained and qualified personnel should move, install, operate or service this equipment.

Follow all local codes.

2.1 Location Considerations

J Series chillers require no special preparation. J Series chillers are designed for installation indoors on a hard, flat, level surface. The room must be free of excessive moisture and corrosive substances.

The chiller must be installed in a location where it is able to dissipate heat efficiently and where there is adequate clearance for service. Leave adequate access to the top of the chiller for filling the tank as needed.

The J Series chiller must be installed at least 3 ft. (1m) from walls or large pieces of equipment that could inhibit airflow.

Airflow into and out of the chiller must not be restricted or deflected in such a way that causes air exiting the chiller to be recirculated into the chiller's air inlet.

The installation location must have the required electrical connections for the J Series' input power. Check the serial tag on the J Series chiller to be sure the available power matches the unit's required voltage and frequency rating. The unit is designed to tolerate deviations of $\pm 10\%$ from the rated line voltage.

The power feed must be connected to a properly grounded source for the J Series' internal grounding to function properly. It is the installer's responsibility to ensure proper grounding. Follow all local, state and national electrical codes in wiring for the J Series.

Figure 5 Installation Clearances

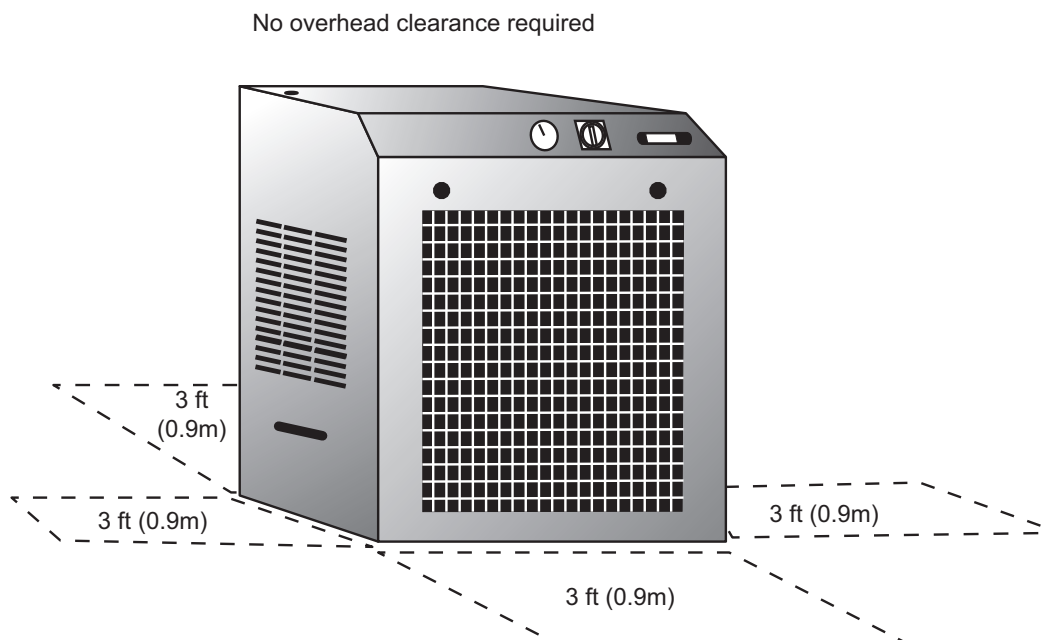

2.2 Unpacking and Positioning

The J Series chiller is shipped on a skid with protective packing that should remain in place until the unit is near its installation location:

- Corrugated cardboard
- Plastic shrink wrap
- Foam corner padding
- Strapping bands

3.0 INSTALLATION

3.1 Checking for Shipping Damage



NOTICE

Keep the J Series upright, indoors and protected from dampness, freezing temperatures and contact damage.

When the J Series chiller arrives and before unpacking it, verify that the shipment matches the bill of lading.

Inspect the J Series chiller immediately for signs of shipping damage visible and concealed. Damage to the cardboard or to the wood skid indicates likely damage and may require removing a panel. For initial access, use a Phillips screwdriver for panel removal.

Report any damage to the carrier and send a copy of the damage claim to Dimplex Thermal Solutions (DTS) or to your sales representative.

3.2 Packaging Material—All Models

Most material used to package this unit is recyclable. Please save it for future use or recycle it.



3.3 Moving the J Series



NOTICE

Improper handling with a forklift or pallet jack can damage the J Series.

Keep the forklift tines level and at a height that will fit below the skid. Lift the skid and chiller only as high as necessary to clear any obstructions on the floor.

Dimplex Thermal Solutions recommends using a forklift or pallet jack to move the J Series chiller for long distances. The unit should be kept in its packing and on its shipping skid while it is moved to its installation location.

Most J Series chillers are equipped with casters for rolling the unit over smooth surfaces. Avoid any large holes or level changes that could cause damage to the casters.

3.3.1 Removing the Chiller from the Shipping Skid

! WARNING

The chiller is heavy. Exercise caution when lifting the unit to prevent it from tipping over. If the unit falls off the forklift or pallet jack's tines, it could cause damage to the unit or other property and could cause injury or death.

To lift the unit, insert the tines all the way under the chiller and spread the tines as far apart as possible. Lift the chiller only enough to slide the skid out from under the chiller.

! WARNING

The chiller is secured to the skid with metal bands under tension. Wear protective clothing, eye protection and gloves when removing the bands. Exercise caution when cutting the bands: they may snap sharply and strike personnel. The edges, particularly the cut ends will be sharp and may be jagged.

The J Series chiller is secured to the skid for shipping with metal bands. To remove the unit from the skid:

1. Move the unit as close as practical to its installation location.
2. Remove the protective carton, using a 3/8" wrench or blade screwdriver (see **Figure 6**). The carton is held in place by eight screws, three on each longer side and one on each shorter side.
3. Cut the two metal bands holding the unit to the skid (see **Figure 6**).
4. Cut or unwrap the shrink-wrap from the unit (see **Figure 6**).
5. Use a forklift or pallet jack to lift the unit until the casters clear the top boards of the skid.
6. Pull the skid from under the unit.
7. Lower the J Series chiller to the floor.
8. Move the chiller to its service location.
9. Lock the casters.

Figure 6 Unpacking the J Series



Remove screws holding carton on skid



Cut metal bands



Cut or unwrap the shrink-wrap

Figure 7 Move the J Series Chiller with a Forklift

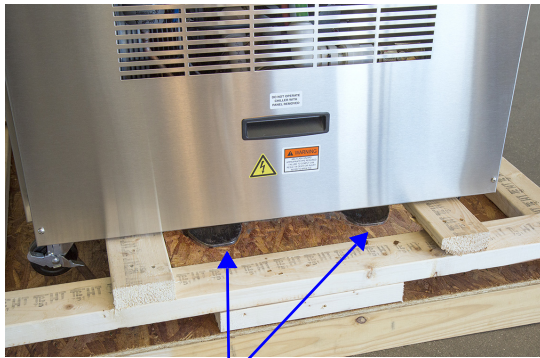

Slide the forklift tines as far under the chiller as possible ...

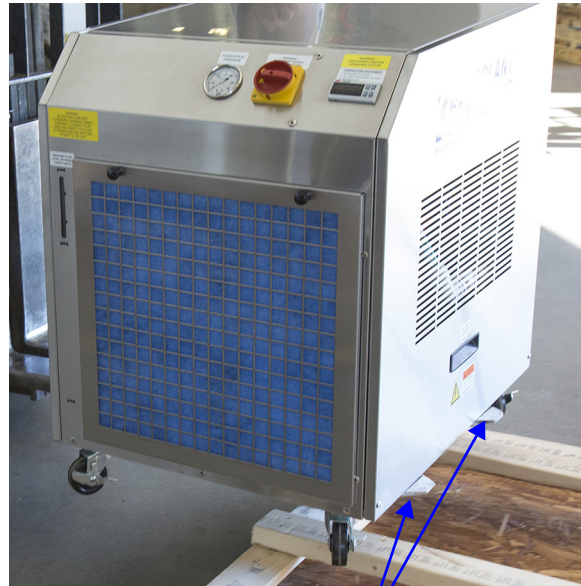

... then slide the forklift tines as far apart as possible before lifting to stabilize the chiller.

3.4 Connections and System Setup

Installing the J Series chiller requires connecting the proper input electrical power, any external monitoring and piping to carry coolant to the application. The unit is charged at the factory with R-134a refrigerant. The coolant tank must be filled with the proper amount of water or water/glycol mixture before startup.

! WARNING

This procedure involves a risk of electric shock that could cause property damage, injury and death.

Electrical connections, particularly hard-wired connections, should be done only by properly trained and certified electricians wearing proper protective gear and using properly insulated tools.

Before beginning to make any electrical connections to the J Series chiller:

- Verify that the input power source matches the J Series chiller's electrical requirements; refer to the specifications information that shipped with the chiller and refer to the nameplate on the chiller.
- Verify that the unit's Main Disconnect on the front of the unit is Off.
- Lock out the input power wiring connections and place a warning tag on the connecting point to prevent power from being reconnected.
- Use a voltmeter to verify that the input power is Off.

! CAUTION

Water and other fluids used in this equipment may leak or be spilled, causing a slip, trip or fall hazard that could cause injury. Hoses are routed throughout parts of the equipment and on the floor during use, which also may pose a hazard.

To reduce the likelihood of a slip, trip or fall hazard, the user must clean up any spilled water around the equipment in a timely manner and route hoses in a manner that will reduce or eliminate the possibility of slipping, tripping and falling.

! NOTICE

Verify that the piping to and from the application to be cooled are correctly connected to the J Series pipes. Improper connections would prevent coolant flow, damaging the J Series and the connected unit. Check the external piping, especially flexible piping, and remove any kinks.

Some models have a factory-installed power cord. The 1.5 ton and 2 ton models, as well as all three-phase models have hard-wired electrical connections; see **Figure 3**. The electrical connections are on the top rear corner of the unit; see **Figure 8**. Hard-wire and control/monitoring terminal blocks are behind a plate at the top left corner of the rear of the chiller. The plate is held in place by four Phillips screws; refer to **Figure 3**.

Inlet and outlet coolant pipes are below the power connections. The unit ships with plastic inserts to protect the pipe threads and to keep foreign matter out of the pipes.

Figure 8 Electrical and Piping Locations—Rear of Chiller

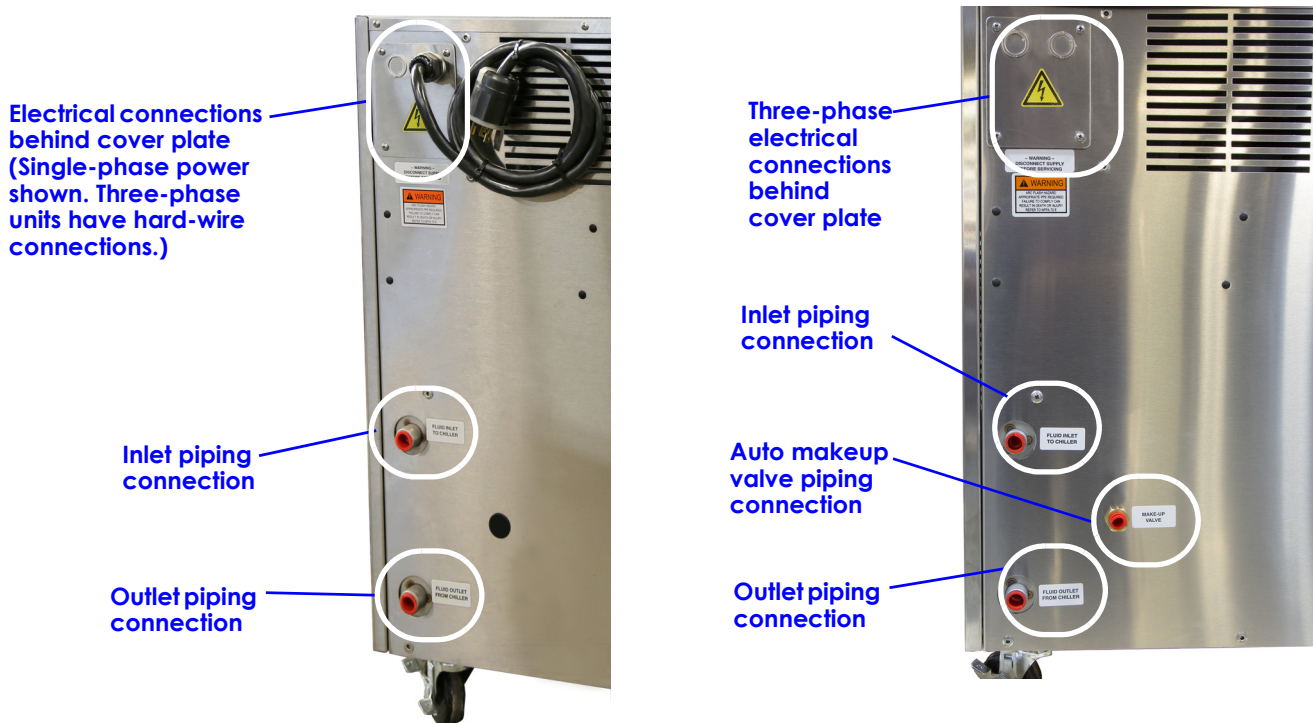

3.4.1 Piping Connections

Before beginning to connect the piping to the J Series chiller, inspect the hoses and piping to be used. Verify that there are no leaks or damaged sections. Connect the piping to a water source and verify that it is clear of debris and contaminants.

To install the J Series chiller:

1. Move the J Series to its operating location.
2. Lock its casters or otherwise immobilize the chiller.
3. Remove the plastic plugs from the inlet and outlet pipes. The inlet and outlet pipes on a unit will be the same size, either 1" or 1/2", depending on the unit size (refer to **Table 1 on page 5** and **Table 1 on page 5**.)
4. **Optional Auto Makeup Valve Connection:** Connect the automatic makeup valve piping to the appropriate refill medium, either water or a water/glycol solution. A float valve in the tank will open the connection when the fluid level drops below the minimum level. The float will shut Off the inflow when the coolant reaches the proper level.
5. Connect the application's piping to the J Series. Note that the J Series chiller's pipes are labeled for proper connection.
6. Check the chiller's strainer to verify that the plug is properly installed (refer to **Figure 4** for the strainer's location).
7. Fill the internal reservoir with the proper amount of coolant, either water or water/glycol. The filler cap is on the top of the chiller.



NOTE

Additional coolant may be required after the J Series has started up and run a short time because the tank will supply coolant to the external piping.

Figure 9 Typical Piping Connections

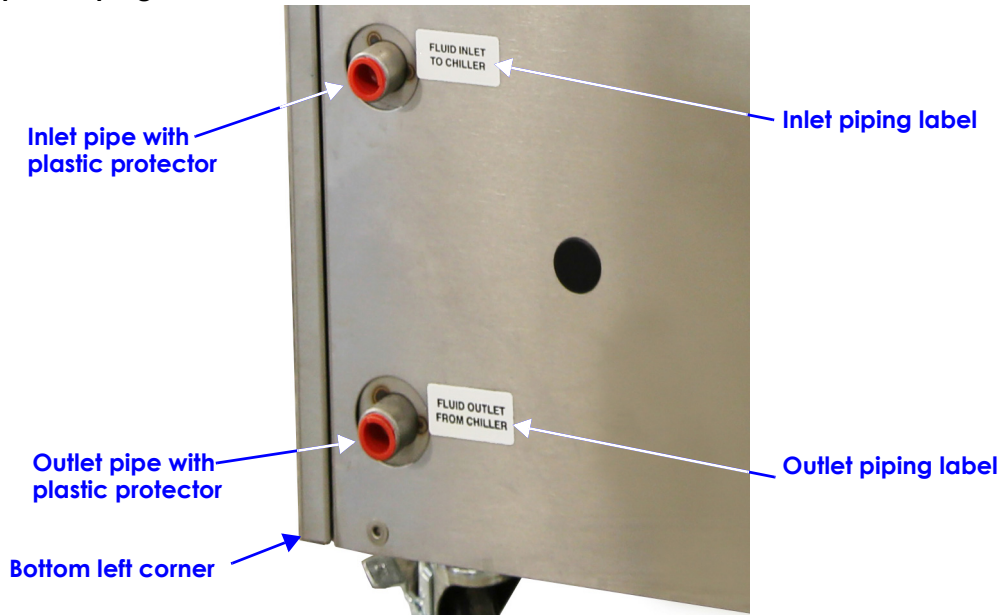

3.5 Process Coolant—Water or Water/Glycol



WARNING

Exercise caution when connecting pipes and wiring. Any holes or cut in the J Series chiller must not reduce the ingress protection of the panel.

DTS recommends using an industrial inhibited glycol and water mixture in its water chiller systems. A proper glycol mixture will prevent freezing and ensure consistent flow at the operating temperature. Inhibited glycols also prevent scale formation and corrosion. Water systems treated with inhibited glycol will also be protected from algae and bacteria that can degrade cooling. Ethylene and propylene are the two standard types of inhibited glycols that can be used in DTS chillers.

- Do not mix different types or brand names of glycol because some inhibitors will precipitate out of the solution.
- Do not use automotive grade antifreeze. These types of glycols are not designed for industrial applications and may cause problems with heat transfer or fluid flow. Many automotive glycols contain silicate-based inhibitors that can coat heat-exchangers, attack pump seals and form a flow-restricting gel.
- Check with the factory before using deionized water. De-ionized water is corrosive at low conductivity levels and it may damage components in some chillers.
- Check state and local codes when selecting the process fluid. Certain areas may have environmental regulations concerning the use and disposal of glycol or other additives.

Call 800-968-5665 to order glycol or visit www.dimplexthermal.com

3.6 Glycol

Consider the following guidelines when using glycol, either alone or as a water/glycol solution.



NOTICE

Check state and local codes when selecting, preparing, using and disposing of the process fluid. Certain areas have environmental regulations about the use and disposal of glycol or other additives.

Failing to follow the relevant state and local codes and the guidelines below may cause damage to the environment, may damage the equipment and contravene environmental law.

Never Mix Glycol Types or Brands

Do NOT mix different types or brand names of glycol. Mixing glycol types or brands can cause some inhibitors to precipitate out of the solution. Mixing glycols may also gel, which will clog filters and prevent proper flow rates. If the type of glycol is changed, the fluid system must be thoroughly drained and flushed.

Never Use Automotive Antifreeze

Do not use automotive grade antifreeze in the chiller. This type of glycol is not designed for industrial applications and may cause problems with heat transfer or fluid flow. Many automotive glycols contain silicate-based inhibitors that can coat heat exchangers, attack pump seals and form a flow-restricting gel.

Ethylene Glycol—For Most Standard Industrial Applications

Ethylene glycol is the standard heat-transfer fluid for most industrial applications. This type of glycol can be used in any application where a low-toxicity content is not required. Ethylene glycol has moderately acute oral toxicity and should not be used in processes where the fluid could come in contact with potable water, food, or beverage products.

Propylene Glycol—For User-Contact Applications

Propylene glycol maintains generally the same freeze protection and corrosion/algae prevention levels as ethylene glycol, but is less toxic. Propylene glycol is more readily disposable than ethylene glycol and safer to handle. Propylene glycol is commonly used in the food industry and in applications where the user may come in frequent contact with the fluid.

Difference Between Ethylene and Propylene Glycol

At very cold temperatures, propylene glycol become more viscous, changing the heat exchange rate slightly. Some chillers are designed to compensate for this viscosity, so either glycol type may be used. Ethylene is more widely used due to its lower cost.

Applications Determine Water/Glycol Mix Percentages

The location of the chiller and environmental concerns must be taken into account when selecting the proper mixture of glycol and water for the chiller process. An indoor process with no chance of freezing will require less glycol than a system located outdoors where low temperatures can cause the fluid to freeze and piping to burst.

Applications with operating temperatures below 20°F (-6°C) should use a glycol mixture equivalent to an outdoor system. After selecting the proper glycol and water types, use the following table to determine the recommended mixture depending on the application and location of the process. The glycol percentage figures in the chart below will apply to any brand of ethylene or propylene glycol.

Table 3 Water/glycol proportions, freezing point

| Application | Glycol % | Water % | Freezing Point |
|----------------------------|----------|---------|----------------|
| Indoor Chiller and Process | 30 | 70 | 5°F (-15°C) |
| Low Temperature | 50 | 50 | -35°F (-37°C) |

Values are based on the performance of Koolant Coolers K-Kool-E brand of ethylene glycol

3.7 Electrical Connections—Input Power



WARNING

Risk of improper wiring. Can cause equipment damage, injury or death.

Installation and service of this equipment should be done only by personnel who have been properly trained in the installation of precision cooling equipment



WARNING

Open all electric power disconnect switches before working within the J Series. Use a voltmeter to verify that power is turned Off before making any electrical connections.

Before proceeding with installation, read all instructions, verify that all the parts are included and check the nameplate to be sure the voltage matches available utility power.

Follow all local codes.



WARNING

Risk of overheated electrical connection terminals can cause equipment damage.

Use copper wiring only. Make sure that all connections are tight.

To connect input power to the J Series.

If the J Series has a factory-installed power cord: Plug the input power cord into an appropriate receptacle.

If the J Series has hard-wire connections:

1. Extract the four screws holding the cover plate (with knockouts) to the J Series cabinet; refer to **Figure 8**.
2. Remove the knockouts required.
3. Strip 1/2" (12.7mm) of insulation from the ends of the input power wiring.
4. Connect strain relief at the required position on the input power wiring and insert it in the knockout.



NOTE

If remote interlock connections will be made, delaying attachment of the strain relief to the input power cable until all connections are made will ease that work.

5. Insert the wiring into the top-terminal wiring blocks, tightening them firmly with the screws. Refer to **Figure 3** for the location of the terminal blocks and to the documentation packet that shipped with the unit for specific connections to the unit.



NOTICE

Improper electrical connections can damage the J Series and the application to be cooled.

Improper connections may cause the motors to run in reverse on three-phase units or may cause a short-circuit, damaging the unit.

The J Series input power connections are labeled. Verify that the input power connections match the J Series labeling and that the input power matches the unit's requirements (check the unit's serial tag).

3.7.1 Electrical Connections—Optional Interlock Wiring

1. Connect the interlock wiring if the optional alarms are present on your unit. Refer to **Figure 3** for the location of the terminal block and to the documentation packet for the wiring diagram. The interlock terminal blocks are marked as 2341 and 2351.
2. Connect the interlock to the equipment as shown in the wiring diagram in the documentation packet that shipped with the unit.

Remote Start Only

3. Remove the factory-installed remote start/stop jumper (purple insulation) on the terminal block inside the J Series cabinet.
4. Replace the jumper with a dry contact. Refer to **Figure 10** for its location.
5. Retain the jumper for replacement if the remote Start/Stop will not be used with all applications.



CAUTION

Any holes or other cut outs must not reduce the ingress protection of the panel, which is IP55.

Figure 10 Interlock Jumper Location

Three-phase unit terminal blocks are shown. Appearance on single-phase models will differ, but the jumper will have purple insulation.

Remote start/stop jumper inside cabinet

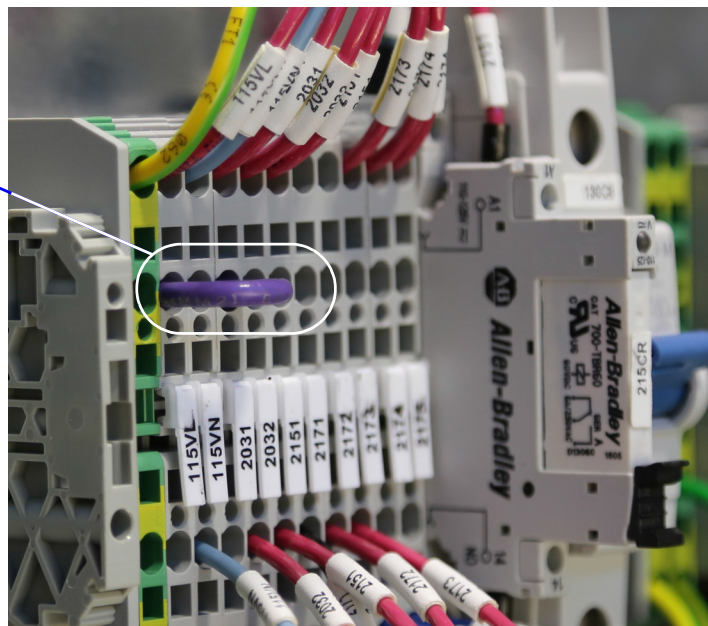

3.8 Check Pump Motor Rotation (Three-Phase Units Only)

Input wiring connections must be correct for the pump motor to operate properly. Making improper phase connections could cause the motor to rotate in the wrong direction. To verify that the motor is rotating properly:

1. Look at the back of the pump motor to see the rotation arrow (see **Figure 11**).
2. Use the power switch on the front of the J Series to briefly power the pump motor so that it rotates a few times. Do not start the unit.
3. Watch the pump motor fan vanes to make sure it is turning as the arrow indicates.

If the pump does not rotate in the proper direction: Swap any two incoming power supply wires and check the rotation again. Do not change the wiring in the pump.

Figure 11 Motor Rotation Indicator

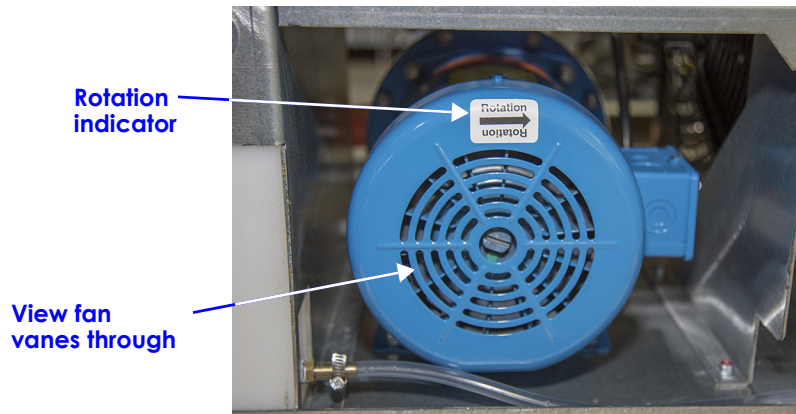

4.0 CHECKLIST FOR COMPLETED INSTALLATION

4.1 Moving and Placing Equipment

- 1. Unpack and check received material.
- 2. Proper clearance for service access and airflow has been maintained around the equipment.
- 3. Equipment is level and mounting fasteners or casters are tight.

4.2 Electrical

- 1. Supply voltage and phase matches equipment nameplate.
- 2. All internal and external high-voltage and low-voltage wiring connections are correct.
- 3. All internal and external high-voltage and low-voltage wiring connections are tight.
- 4. The unit is properly grounded to an earth ground.
- 5. Control transformer setting matches incoming power.
- 6. Electrical service conforms to national and local codes.
- 7. Pump rotates in the correct direction.

4.3 Piping

- 1. Piping has been checked for leaks.
- 2. Piping has been flushed to clear debris, pipe dope and contaminants.
- 3. The plug for the chiller's internal strainer is installed.
- 4. Piping is properly supported and is not kinked.
- 5. Piping to and from the chiller is at least the same size as the chiller connections.
- 6. Coolant reservoir is filled and closed.
- 7. No closed valves exist between the chiller and the application to be cooled.

5.0 OPERATION

5.1 Initial Startup



CAUTION

All startup procedures must be followed precisely and performed in sequence. Failing to follow these procedures may cause damage to the unit, loss of coolant to the application and injury to personnel.

If trouble is encountered in putting a chiller in operation, the fault can often be traced to one of the control or safety devices. This outline can be used as a checklist for the initial startup and for subsequent startups if the chiller is taken out of service for a prolonged period.

- ___ 1. Verify that the main power source is connected properly and that it matches the voltage shown on the nameplate of the unit.
- ___ 2. Verify that all process chilled fluid piping connections are secure.
- ___ 3. Turn the main power On using the Main Disconnect on the front of the unit.
- ___ 4. Check the coolant flow.
- ___ 5. Check the coolant tank; any empty area in the piping will fill from the tank and it may require additional coolant.
- ___ 6. Check the coolant temperature on the LCD on the front of the unit.

5.2 Chiller Shutdown



CAUTION

All shutdown procedures must be followed precisely and performed in sequence. Failing to follow these procedures may cause damage to the unit, loss of coolant to the application and injury to personnel.

To shut down the unit without disconnecting from the process:

1. Move the Main Disconnect to the Off position.
2. Maintain electrical power to the unit at all times except for service purposes.

To shut down the unit and disconnect from the process:

1. Move the Main Disconnect to the Off position.
2. Shut chiller disconnect Off.
3. Disengage the electrical supply to the chiller at the disconnecting device.

5.3 Basic Operation

The IR33 display will show the temperature of Probe B1 (fluid temperature). Other display options include temperature of Probe B2 (ambient temperature when used) and Setpoint 1 (St1) (temperature setpoint).

Other inputs and outputs may be used for specific applications. For those settings, refer to the program settings sheet in documentation package.

If the function of the controller is not being used it will display *n0*. To change the default screen information, use the *Down* arrow key and scroll to the desired display option. While scrolling, the display will flash between the parameter name and the value of that parameter. To select the desired display option hold the *Set* key for 3 seconds. If nothing is selected, the display will stop flashing and will return to the previous display option.

5.3.1 Changing the Setpoint

To change the setpoint, press and hold SET until *St1* appears. Use the Up and Down arrows to select the desired setpoint. Press SET to save.

6.0 TROUBLESHOOTING

Fan Overload, Low Pressure and High Pressure: These faults will prevent the compressor from starting, but will not display an error on the controller. If not resolved the fluid temperature will rise and trigger an overtemperature alarm at 10°F (°C) above the current setpoint.

Pump #1 Overload: This fault will cut power to the controller and all control circuits. To reset this fault, the Pump #1 overload must be reset manually in the electrical enclosure.

Overtemperature Fault: Output 1 relay will open and 1 will no longer be displayed on screen.

Error Codes that may display:

E01: Probe B1 error, check connection (Fluid Temperature Sensor).

E02: Probe B2 error, check connection (Ambient Temperature Sensor).

E04: Extreme over temperature (alarm will sound*).

E05: Extreme under temperature (alarm will sound*).

Any other codes will require service.

* Pressing mute will silence the audible alarm.

Table 4 IR33 Troubleshooting Guide

| Problem | Possible Cause | Corrective Action |
|---|----------------------|--|
| Controller displays E01. | Probe 1 fault. | Turn Off main disconnect. Check NTC plug for tight, metal-to-metal connections. If connections are loose, remove the NTC plug and re-tighten the wires in the plug, then reconnect the plug to the controller. |
| Controller display alternates between b1, ST1, or ST2, and the value. | b1 input is not set. | Press the <i>Up</i> or <i>Down</i> arrow until b1 is displayed; press <i>Set</i> for 3 seconds to confirm setting. |
| Controller display alternates between b2, di1, or di2, and n0. | b1 input is not set. | Press the <i>Up</i> or <i>Down</i> arrow until b1 is displayed; press <i>Set</i> for 3 seconds to confirm the setting. |
| Controller displays steady n0. | b1 input is not set. | Press the <i>Up</i> or <i>Down</i> arrow until b1 is displayed; press <i>Set</i> for 3 seconds to confirm the setting. |

Table 5 Troubleshooting

| Problem | Possible Cause | Corrective Action |
|--|---|--|
| Chiller will not turn On. (No display on temperature controller) | No power to Chiller | Check power feed to Chiller. |
| | Main disconnect is turned Off. | Turn On main disconnect. |
| | Blown fuses | Check for and replace blown fuses. |
| | Tripped starter overloads | Reset any tripped overloads. |
| | Low fluid level in tank | Fill tank |
| Chiller turns On but nothing happens. (Display is On but no pump or cooling cycle) | Remote signal is not active | Check remote connection for signal. |
| | Fault present within Chiller | Determine fault and clear if possible. |
| | Fluid pump is not operating | Check pump overload and power to contactor. |
| | Blown fuses | Check and replace fuses. |
| | Incorrect phase rotation | Correct phase rotation at main disconnect. |
| Fluid pump is On but does not create required pressure or flow. (Flow fault condition) | No fluid present at pump suction | Check fluid level and ensure there is fluid at the pump's suction. |
| | Incorrect phase rotation | Correct phase rotation at main disconnect. |
| | Pump / fluid system is air-bound. | Vent pump cavity to flood the suction. |
| | Fluid line size too small. | Increase fluid lines outside the Chiller. |
| | Fluid/filters dirty | Clean fluid and change filters. |
| | Pump discharge closed or blocked | Ensure all fluid lines are open to flow. |
| Fluid pump is operational but the refrigerant compressor will not run. | Fluid temp is below setpoint. | Allow fluid system to increase in temperature. |
| | Inadequate fluid flow | Correct fluid system to establish flow |
| | Low refrigerant pressure | See "Low refrigerant fault" section. |
| | High refrigerant pressure | See "High refrigerant fault" section. |
| | Compressor overload is tripped. | See "Compressor overload" section. |
| | Compressor lube protector tripped (if equipped) | Reset lube protector. |
| | Blown fuses to compressor | Check and replace blown fuses. |
| | Faulty temp controller output | Consult DTS customer service department. |
| Bad compressor | Consult DTS customer service department. | |
| Chiller is running but does not maintain the desired fluid temperature. | Fault present within Chiller | Determine fault and clear if possible. |
| | Incorrect phase rotation | Correct phase rotation at incoming power. |
| | Fluid or heat exchanger is dirty. | Replace fluid and clean fluid system. |
| | Loss of flow or fluid level | Check fluid system for free flow and ensure Chiller has adequate fluid level. |
| | Low refrigerant pressure. | Restart Chiller or clear fault on controller. See "low refrigerant fault" section. |
| | Ambient temperature too high | Ensure Chiller is operating within its designed ambient temperature specification. |
| | Heat load exceeds Chiller's capacity. | Reduce heat load to Chiller if possible. Check the factory specifications to ensure the Chiller is not being operated more than $\pm 10^{\circ}\text{F}$ of the original temperature setpoint or fluid flow. |

Table 5 Troubleshooting (continued)

| Problem | Possible Cause | Corrective Action |
|---|--|--|
| Low refrigerant pressure fault (automatically resets when acceptable pressure is reached) | Low ambient air temperature | Ensure Chiller is operating within its designed ambient temperature specification. |
| | Loss of fluid flow through evaporator | Check fluid flow and ensure evaporator is clean. |
| | Loss of refrigerant | Have a refrigeration technician leak check unit and charge with the appropriate refrigerant. |
| | Refrigerant solenoid not functional | Check wiring to solenoid or replace valve. |
| | Faulty pressure switch | Replace pressure switch. |
| | Compressor crankcase not warm or faulty crankcase heater | Ensure main power disconnect has been on for at least 8 hours prior to use. Replace crankcase heater if faulty. |
| High refrigerant pressure fault - (automatically resets when acceptable pressure is reached) | Air filters dirty | Clean filters (see 7.0 - Maintenance). |
| | Condenser dirty | Clean condenser (See 7.0 - Maintenance). |
| | Incoming air too hot | Ensure that the Chiller is properly ventilated with fresh air not exceeding 90°F (32°C), unless designed for high-ambient temperature operation. |
| | Inoperative fans | Check for blown fan fuses. |
| | Back panel out of Chiller | Ensure all covers and panels are in Chiller. |
| | Phase rotation incorrect | Correct phase rotation at incoming power. |
| | Refrigerant system overcharged | Have a refrigeration technician ensure the system is properly charged. |

7.0 MAINTENANCE

Establishing and following a proper maintenance schedule will substantially reduce down time, reduce repair costs and extend useful lifetime for the chiller. Any cost of implementing these procedures will almost always more than pay for itself.

Prepare a checklist of the recommended service operations and when they are to be performed. A suggested list is included in **7.4 - Suggested Maintenance Checklist**. The checklist includes voltage readings, amperages, etc. so that they can be monitored over time. With this information, maintenance personnel may be able to correct a potential problem before it causes any downtime. For best results, these readings should be taken with a full heat load from process, preferably with similar operating conditions each time. The following is a list of suggested periodic maintenance.

Record all maintenance and repair work carried out on the unit and auxiliary equipment. The frequency and the nature of the work performed over a period can reveal adverse conditions that should be corrected and will reduce maintenance.

If replacement parts are needed use only original replacement parts.

Contact Dimplex Thermal at 800-968-5665 for service, support or parts.

7.1 Cleaning External Electrical Parts

If it should become necessary to clean this equipment, disconnect the unit from its power source first. Do not use liquid cleaners, aerosols, abrasive pads, scouring powders or solvents, such as benzene or alcohol. Use a soft cloth lightly moistened with a mild detergent solution. Ensure the surface cleaned is fully dry before reconnecting power.

7.2 Cleaning Contaminated Refrigerant System

Cleaning out a very heavily contaminated refrigerant system, such as might result from a refrigerant compressor burnout, may require services of a properly trained and qualified refrigeration engineer.

7.3 Maintenance Guidelines

Disposing of parts and waste material of any type must comply with national, state and local regulations. No waste material, solid or liquid, should be disposed of in a manner that drains into or placed into any body of water. Never burn waste. Recycle waste material when possible.

Use only the type of refrigerant gas specified on the unit's serial plate.

Follow all instructions about operation and maintenance strictly.

Maintain the chiller and all ancillary equipment and safety devices in good working order. Keep the unit clean. Cover components and openings during long idle periods and repair work.

Check the accuracy of temperature and pressure measuring devices regularly. Replace any measuring devices that show inaccurate readings.

7.4 Suggested Maintenance Checklist

7.4.1 Maintenance Checklist—Weekly

- ___ 1. Inspect and clean condenser and air filter.
Excessive buildup of dirt, oil and other debris on the condenser coil will cause refrigerant pressures to increase and prevent operation at full capacity. Ensure that the fins of the condenser are clean and not damaged to keep airflow at a maximum. Use compressed air at no more than 30 psi (2.0 bar; 200kPa) to blow out the condenser in the opposite direction of air flow.
- ___ 2. Check to make sure that the temperature is maintained close to the setpoint temperature. If the temperature stays more than 5°F (3°C) from the setpoint, there may be a problem with the chiller. If this is the case, refer to **Table 4** or contact the Dimplex Thermal Solutions service department.
- ___ 3. Check the process fluid to be sure it is clean and free of contaminants. Check the reservoir, for debris and contaminants. Test the process fluid to ensure proper freeze and corrosion protection.
- ___ 4. Check for normal inlet and outlet fluid pressures through the chiller. A large pressure differential could indicate a plugged heat exchanger or dirty tank.
- ___ 5. Check refrigerant sight glass for air bubbles or moisture indication. If the sight glass indicates a refrigeration problem, have the unit serviced as soon as possible.
- ___ 6. Check the in-line strainer and remove any buildup. The fitting removes with a wrench, either 1/4" or 1/2".
- ___ 7. Inspect the fluid filter shortly after startup to determine how frequently they need changing. Set up a schedule for replacing the filter.
- ___ 8. Inspect all internal and external wiring for loose connections and damage.
- ___ 9. Check voltage and current draws on all motors and heaters. Refer to the chiller's electrical schematics or the motor nameplate for proper voltage and amperage ratings. Readings should be $\pm 10\%$ of the nameplate value and have a maximum difference of $\pm 2\%$ between each phase.
- ___ 10. Check the inside of the chiller for evidence of refrigerant leaks, such as oil spots or refrigeration lines covered in oil. Have a certified refrigeration technician make any repairs.

7.4.2 Maintenance Checklist—Monthly

- ___ 1. With the main disconnect shut Off, check the condition of electrical connections at all contactors, starters and controls. Check for loose or frayed wires.
- ___ 2. Check the incoming voltage to make sure it is within 10% of the design voltage for the chiller.
- ___ 3. Check the amp draws to each leg of the compressor and pump to confirm that they are drawing the proper current.

7.4.3 Maintenance Checklist—Every Three Months

- ___ 1. Have a qualified refrigeration technician inspect the operation of the entire unit to ensure proper operation.
- ___ 2. Have condenser cleaned if necessary.

7.4.4 Electric Panel

The electric panel should be inspected for any loose electrical connections.



WARNING

Risk of electric shock. Can cause injury or death.

Open all local and remote electric power disconnect switches before working within the unit.

Be sure that power to the unit is shut down before attempting to tighten any fittings or connections.

7.4.5 Filter

The J Series chiller filter is in front of the unit, behind the grille. The fiberglass mat must be installed so that the blue side faces the interior of the J Series chiller.

The filter should be inspected periodically, based on how much dust and other airborne debris is in the air. The filter can be cleaned if care is exercised, but it should be replaced when needed. The filter lays in the recessed front grille, which is hinged for easy opening. The grille on J Series chillers with the optional filter has knurled knobs for opening (See **Figure 12**).

Figure 12 Filter Replacement

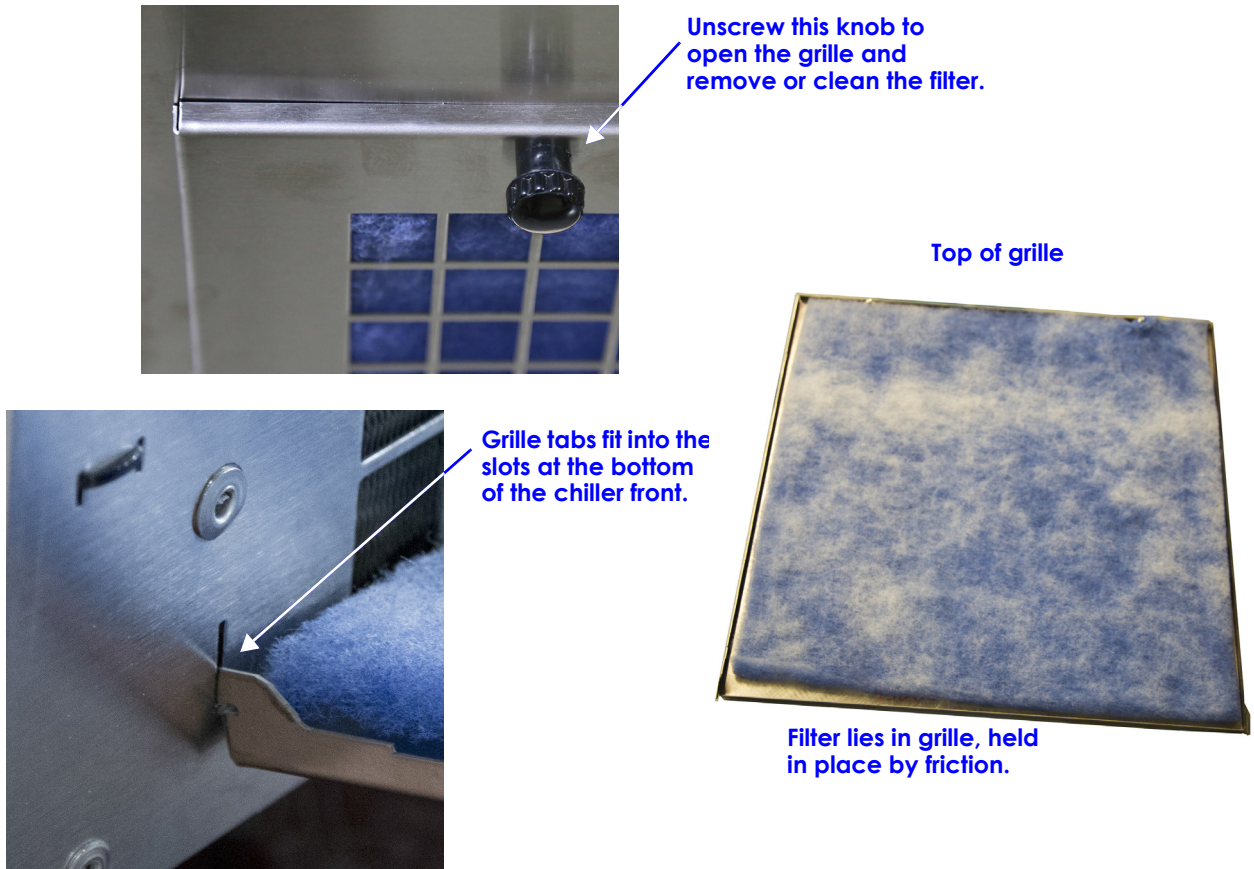

8.0 DISPOSAL AND RECYCLING INFORMATION

Most of the J Series chiller's components can be recycled when the unit reaches the end of its serviceable life. Fluids used in the chiller may be harmful to the environment and must be recycled or disposed of properly.



NOTICE

Check state and local codes when selecting, preparing, using and disposing of the process fluid. Certain areas have environmental regulations about the use and disposal of glycol or other additives.

Failing to follow the relevant state and local codes and the guidelines below may cause damage to the environment, may damage the equipment and contravene environmental law.

8.1 Recycling Methods

Hydraulics, lubricants and other fluids used in the J Series chiller must be recycled as required by local, state and national environmental laws and regulations. They must not be discharged into any type of sewer system or waterway or poured on the ground.

Electronics must be recycled as required local, state and national environmental laws and regulations. Many electrical and electronic components contain hazardous elements. These must be recycled. They must not be disposed of in waste disposal systems.

Metals and other parts of the J Series chiller must be recycled as required by local, state and national environmental laws and regulations.

APPENDIX A - SPARE PARTS

The Dimplex Thermal Solutions Parts Department offers replacement parts for any component of your Koolant Coolers, Schreiber and Riedel brand chillers. Some parts, such as filters and fuses, are offered singly, but DTS also offers replacement parts kits (see **Table 6**).

After-Market Part Sales for Spare and Consumable Parts

The Dimplex Thermal Solutions Parts Department offers a complete line of replacement pumps, motors, compressors, evaporators and glycol for your Koolant Coolers, Schreiber and Riedel brand chillers. DTS also offers accessories such as anti-back flow kits, filter kits, and flow meters for your unit. We are able to ship almost every item the same day you order.

DTS has a dedicated parts warehouse fully stocked with more than 1,000 parts, which are ready to be shipped the same day if orders are placed by 3 pm EST weekdays except holidays.

Generic Spare Parts List for J-Series Chiller

Spare parts lists are available for all chillers. If down-time is not an option and your application is critical, DTS can create a specific spare list for your chiller. To request a free spare parts list, contact partsdept@dimplexthermal.com, or call 1-800-968-5665, with your model number and serial number.

Each kit purchased will include a one-year parts warranty.

Any combination of spare parts kits can be purchased.

Call or email for your custom Spare Parts List with part numbers, pricing and availability of the components specifically used in your chiller.

Table 6 Replacement Parts Kits

| | |
|-------|--|
| Kit 1 | Air Filter(s) |
| | Fluid Filter - If option on unit |
| | Pump Seal Kit - If option on unit |
| | Temperature Controller |
| Kit 2 | Pump |
| | Pump Contactor |
| | Pump Overload - If option on unit |
| | Fan Assembly - If option on unit |
| Kit 3 | Compressor or Condensing Unit |
| | Crankcase Heater - If option on unit |
| | Compressor/Fan Contactor |
| | High Pressure Switch - If option on unit |
| | Low Pressure Switch - If option on unit |
| | Expansion Valve |
| | Temperature Sensor - If option on unit |

APPENDIX B - SERVICE

Dimplex Thermal Solutions offers these additional products and services:

- Startup Assistance
- Planned Maintenance
- Chiller Registration
- Factory Refurbishments
- Service Evaluations and Repairs

DTS ensures that every chiller provides optimal, efficient cooling performance today and in the future.

Proper maintenance ensures not only the life of the chillers, but also improves the quality of process output. Through component sales, site visits and 24-hour technical support, DTS demonstrates Complete Customer Care to bring you the best possible outcome.

Startup service and planned maintenance contracts are efficient and economical ways to ensure your DTS equipment provides optimum performance with trouble-free operation for years to come. These services are especially valuable and recommended in the instances of large capacity, multi-module, or otherwise complex applications, or where it is known that units will be located in facilities that lack personnel with a basic understanding of refrigeration circuits. These services are a stand-alone product, to be purchased separately from the cost of your DTS equipment.

B.1 STARTUP ASSISTANCE SERVICES

When startup service is purchased, a DTS certified contractor will be dispatched to the site during the initial startup or reinstallation if a unit has been relocated or installed with new process equipment. **Startup Service is not an installation service.** Startup Service checks the overall operation of DTS equipment and how it has been integrated into the associated heat process application, while performing within the actual ambient conditions of the facility. Startup Service technicians will check the overall operation of equipment and how it has been integrated into the associated heat process application, while performing within the actual ambient conditions of your facility.

Startup Service includes:

- A check of the overall installation to ensure the DTS product has been installed in a way that allows for future service, proper air circulation, and correct anchoring
- Check of field piping for proper sizing and configuration, proper fluid flow and pressure, leak checks, fluid levels, and verification that any necessary valves have been installed, as necessary
- Check of incoming power supply; proper compressor, fan and pump rotation; amperage draws; correct field wiring to specification; and controls verified in good operation
- Check of refrigerant pressures, and adjustment of solenoids and valves, as necessary, to fine-tune the chiller operation to meet the ambient conditions and actual heat loads of the associated processes.
- Instruction for use, maintenance, and basic troubleshooting for the facility's operators and/or maintenance staff

Guidelines for Arranging a Startup Assistance Visit

- DTS Customer Care representative will contact customer service to schedule service. This usually happens within a week of the chiller shipping from DTS.
- Service can be requested by emailing: industrial_service@dimplexthermal.com
- The pre-startup checklist must be completed and returned to DTS prior to service being arranged.
- DTS Customer Care representative will schedule a date and time.
- The Startup Assistance program covers services during standard business hours.

B.2 PLANNED MAINTENANCE SERVICES

Planned Maintenance (PM) Contracts consists of regularly scheduled visits to perform operational checks upon existing cooling equipment. Contracts can vary in length and may be purchased at any time during the life of the equipment. These contracts can be of extra value to facilities that do not staff their own equipment maintenance crews, making it possible to maintain the equipment at optimum performance and to protect this investment without having to train or hire technically advanced personnel. Planned Maintenance can also diagnose potential problems and the need for replacing wearable components before failure can cause a lost productivity event.

Planned Maintenance Service

- Check of overall operation to ensure chiller is maintaining capacity within seasonally changing ambient conditions, adjustments as necessary to fine-tune to customer's needs.
- Check and clean or change air and water filters.
- Check the condition of water, fill levels, glycol ratios, also checking plumbing lines for leaks, flow rates and water pressure (if optional pressure gauge is installed).
- Check voltage supply to chiller, component amperages, and electrical panel wiring.
- Check refrigerant pressures, superheat, sub-cooling, cleanliness of condensing coils, and condition of wear parts.
- Review of unit condition with on-staff personnel.



NOTE

DTS and our DTS certified contractors will change water filters and fill water reservoirs to appropriate levels when needed at these visits. However, it is the customer's responsibility to maintain a supply of these consumable products, available from the DTS Parts Department. The intent of this service is to prevent unnecessary down time of cooling equipment by keeping it in optimum operating condition through regular visits. The customer will be advised of any non-warranty work necessary, such as the replacement of wearable parts.

B.3 ONLINE CHILLER REGISTRATION

DTS sells chillers around the world, often bundled with other manufacturers' equipment. To provide a reliable chiller service network across the United States and bordering areas, we ask our customers to register their chiller's site location with our Service Department. Our team will map your location and make efforts to provide a reliable service experience in your area for years to come.

As soon as chiller location is known, DTS requests that our online product registration page be completed, this is located on our website at: <http://www.dimplexthermal.com/service/register-chiller-location/>

We are continuing to grow our global presence and service offerings. Services outside of the United States will have different response times and will abide by local standard business hours and recognized holidays.

Product registration is quick and easy, yet provides peace of mind knowing there is a certified contractor available locally to maintain optimal performance of your process.

B.4 DTS FACTORY REFURBISH PROGRAM

Our refurbishment center allows chillers to be returned to our facility to be evaluated, cleaned, repaired and factory tested to the designed specifications. All repairs are handled by our in-house factory technicians. Components are replaced with OEM parts or engineering approved replacements, most of which are in stock. Standard refurbishments can be evaluated, repaired, tested and re-shipped within two weeks. The savings associated with factory refurbishing can be more than half the cost of on-site/field repairs.

Contact Aftermarket Sales and Service Department at: partsdept@dimplexthermal.com and we will get started ensuring that your chiller provides optimal, efficient cooling performance today and in the future.

B.5 SERVICE EVALUATIONS AND REPAIRS

DTS has a certified contractor network that covers Canada, Mexico and the United States, developed to quickly address and take care of customers' needs. DTS has vetted each certified contractor to provide quality, professional, timely service to our customers and their customers. There are many benefits of working directly with DTS for any service issues (both warranty and non-warranty):

- Free 24/7 phone support
- Services provided by our vetted, nationwide DTS certified contractor base
 - We ensure contractors who are familiar with the DTS chillers.
 - We provide drawings and manuals to your specific chiller before the contractor arrives on site.
 - Our contractors have direct access to our in-house support technicians and engineers while at your facility.
- Ability for us to track a unit's history
 - By being able to track a unit's history and our customer's overall history, DTS is able to be proactive, to make informed decisions about design changes or upgrades.
 - Notice any recurring issues that require investigation.

Contact Aftermarket Sales and Service Department at 800-968-5665 or partsdept@dimplexthermal.com for an evaluation and estimate.

APPENDIX C - WARRANTY

WARRANTY OF WORKMANSHIP AND MATERIALS THE IMPLIED WARRANTIES OF MERCHANTABILITY AND OF FITNESS FOR A PARTICULAR PURPOSE AND, EXCEPT AS SPECIFICALLY SET FORTH HEREIN, ALL OTHER WARRANTIES AND REPRESENTATIONS, EXPRESSED OR IMPLIED, ARE HEREBY DISCLAIMED AND EXCLUDED BY THIS AGREEMENT. THERE ARE NO WARRANTIES THAT EXTEND BEYOND THE DESCRIPTION HEREOF. SELLER'S WARRANTIES HEREIN APPLY ONLY TO THE ORIGINAL PURCHASER AND DO NOT EXTEND, EXPRESSLY OR BY IMPLICATION, TO ANY OTHER PERSON OR PERSONS. Seller guarantees all North American installed equipment and materials of its manufacture or start-up services performed by Seller against defects in workmanship and material-under normal and intended use, service, maintenance and proper installation-for a period of and eighteen (18) months for Koolant Kooler Brand Chillers from date of shipment. Equipment installed outside of North America will be warranted for parts only, standard delivery shipment. The Seller obligation under this agreement is limited solely to repair or replacement at Seller's option, in Seller's factory or in the field, with Seller approval, within said warranty period. If the equipment is returned to Seller's factory, the unit must be returned freight prepaid, with prior approval from Seller, with Buyer having obtained a returned goods authorization (RGA) number from Seller. Seller will make any needed repairs at no charge to Buyer if the damage is determined not to be the fault of the Buyer. Seller will then return the equipment to Buyer freight prepaid; in other words, Seller will be responsible for one leg of the transportation costs. The above warranty shall not apply to any equipment, or components thereof, which have been subject to abnormal or improper use, negligence (including failure to maintain the equipment as recommended in writing by Seller) or accident or which have been altered or repaired by other than Seller or Seller's authorized representative. Nothing shall be construed as an additional warranty unless specifically designated as such in writing and signed by Seller ("Additional Warranty"). The Additional Warranty shall be subject to the provision of this document as to duration and limitation of remedy, unless the Additional Warranty expressly amends such provisions. The above warranty shall not apply to any parts sold independently of the unit sold. All parts sales are subject to ninety (90) day warranty.

(Effective Date 7-5-2012)

Scan the QR code for quick access to online manuals. This requires having the chiller's serial number and model number.



Contact the Parts Department to replace printed manuals; fee \$100.00 each. Price subject to change without notice.

 **Dimplex** | Thermal Solutions

Koolant Coolers J Series | **USER MANUAL**

Assembled in the USA

ISO 9001 Certified

Dimplex | Thermal Solutions

2625 Emerald Drive
Kalamazoo, MI 49001
Toll Free: 800.968.5665
Phone: 269.349.6800



Technical Support: serviceteam@dimplexthermal.com
Sales: salesdept@dimplexthermal.com
Service and Parts: partsdept@dimplexthermal.com

DTS-KKJS-2017

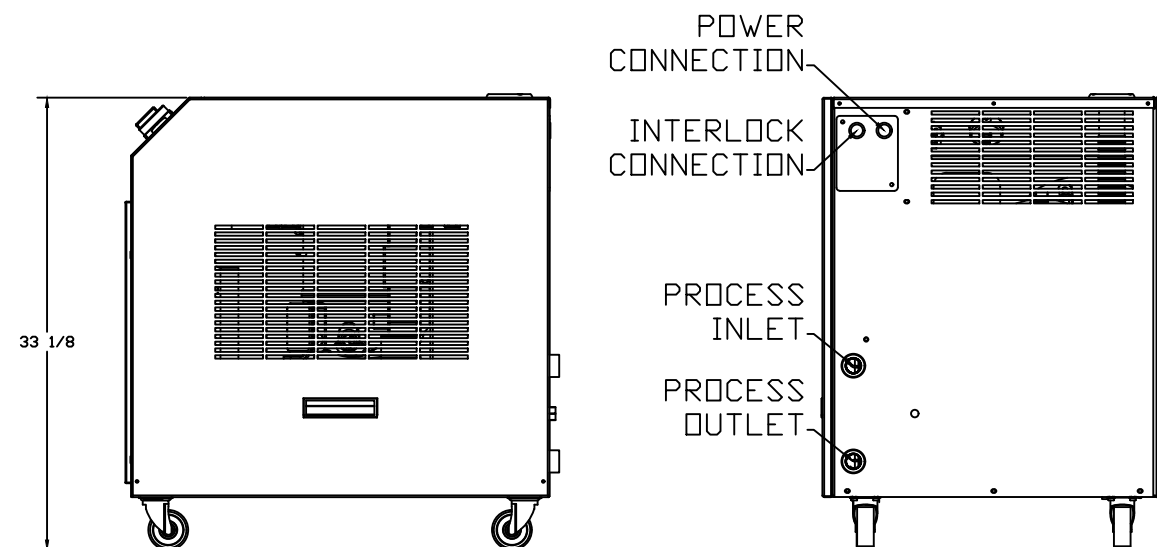
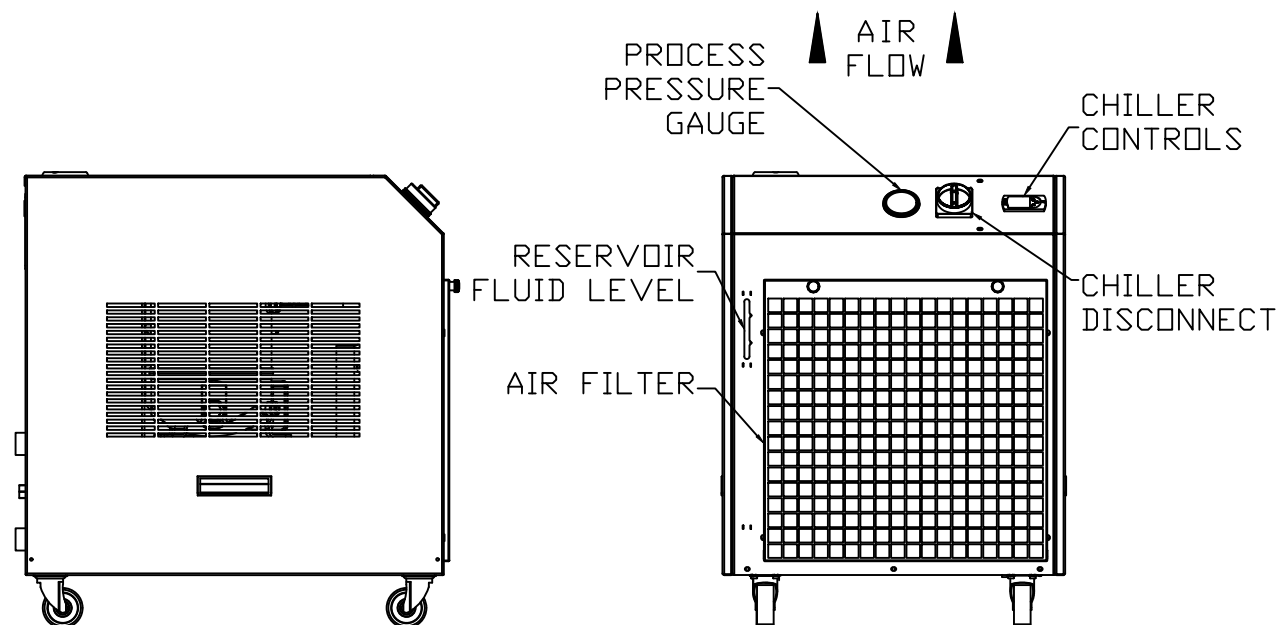
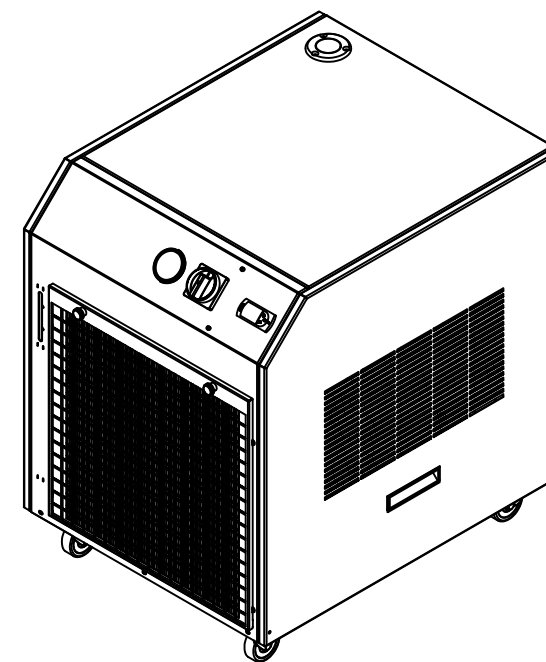
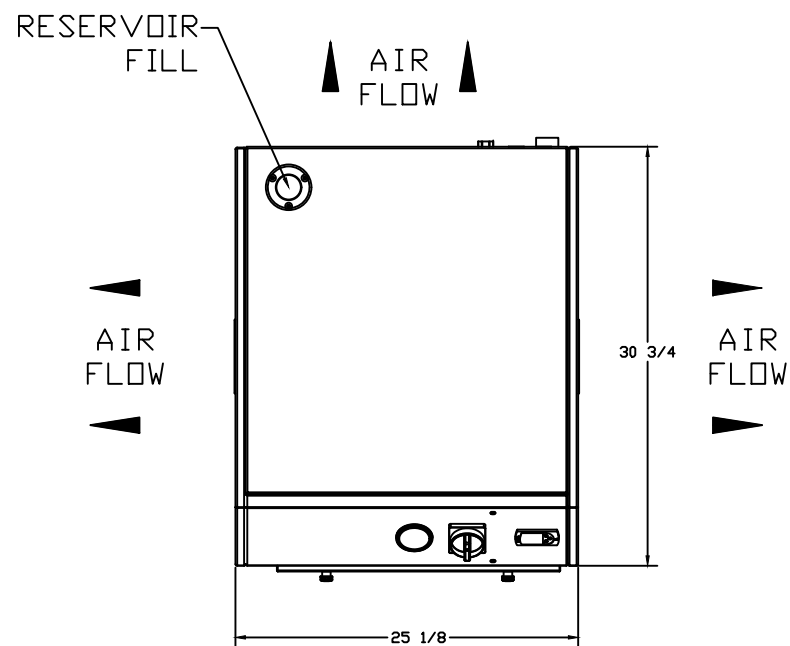

ALL DIMENSIONS ARE IN INCHES

THIS PRINT CONTAINS INFORMATION PROPRIETARY TO DIMPLEX THERMAL SOLUTIONS AND MAY NOT BE DUPLICATED, REPRODUCED, OR SHARED IN ANY WAY WITHOUT THE EXPRESSED WRITTEN CONSENT OF DIMPLEX THERMAL SOLUTIONS.

CONFIDENTIAL AND PROPRIETARY

| DATE | DESCRIPTION OF REVISION | APPROVED BY |
|----------|-------------------------|--------------|
| 05/19/15 | REMOVED AIR FILTER NOTE | JP,KB,00XXXX |
| 05/19/15 | INITIAL RELEASE PRINT | JP,KA,N/A |

Dimplex
Thermal Solutions

Koolant
Koolers

DESIGN BY: CJS
DATE: 10/15/14

DRAWN BY: CJS
PAGE 1 OF 1

KALAMAZOO, MI.
PH (800) 968-5665
WWW.DIMPLEXTHERMAL.COM

J SERIES 1.5 TON

LAYOUT (MC MACHINE)

DRAWING NO. 102110

TAGGING INSTRUCTIONS

- A) MANUALS MUST SHIP WITH MACHINE OR MACHINE DOES NOT SHIP.
- B) PLACE ADDITIONAL TAGS INSIDE THE MACHINE.
- C) PLACE ADDITIONAL TAGS INSIDE THE ELECTRICAL ENCLOSURE MOUNTED ON TAG RAILS WHICH ARE RIVETED TO THE PANEL. ADD NOTE TO ELECTRICAL PRINTS.
- D) TAGS OUTSIDE AND OUTSIDE THE ELECTRICAL ENCLOSURE NEED TO BE RIVETED.
- E) TAGS INSIDE THE MACHINE NEED TO BE RIVETED.
- F) SEQUENCE OF OPERATION TAG REQUIRED
- G) INLET AND OUTLET TAGS ONLY TO BE RIVETED.
- H) SPECIAL LANGUAGE TAGS ARE REQUIRED.
 - FRENCH GERMAN
 - SPANISH OTHER

SPECIAL INSTRUCTIONS:

* 0612638 SHOULD BE ASSEMBLED AND THEN PACKED FOR SHIPPING.

* 56°F SET POINT LABEL SHOULD BE MOUNTED ABOVE CONTROLLER (SEE ELECTRICAL PRINT).



| NO. | DESCRIPTION | PART# | QTY | TYPE |
|-----|-------------------------------------|---------|-----|------|
| | JHI-1501-MIT-R1-CE-M 460/3/60 | 800251 | | ASSY |
| 010 | PANEL FRONT 29.25X23.63X5.25 18GA | 458786 | 1 | PC |
| 020 | PANEL BACK 29.13X23.63X.75 18GA 430 | 458832 | 1 | PC |
| 030 | DOOR VENTED 29.25X30.63X.75 18GA | 458835 | 1 | PC |
| 040 | DOOR VENTED 29.25X30.63X.75 18GA | 458834 | 1 | PC |
| 050 | RISER PUMP/COMPRESSOR | 306495 | 1 | PC |
| 060 | BRACE REFRIG 15.5X13.25X10 12GA | 458787 | 1 | PC |
| 070 | LID SOLID 31.93X27.93X.88 18GA 430 | 458833 | 1 | PC |
| 080 | BASE JH 30.5X23.43X.75 12 GA GALV | 458785 | 1 | PC |
| 090 | COVER ELEC 5.5X4.5 18GA 430 | 458772 | 1 | PC |
| 100 | BRACKET PLUMBING ASSY 1IN NPT | 700198 | 1 | PC |
| 110 | BRKT BP BACK 9.31X3.25X6.06 14GA | 458790 | 1 | PC |
| 120 | BRKT BP FRONT 5.19X3.38X3 14GA GALV | 458789 | 1 | PC |
| 130 | JH-1501-M PLUMBING | 102120 | 1 | ASSY |
| 140 | JHI-1500-M REFRIGERATION 460/3/60 | 702005 | 1 | ASSY |
| 010 | JHI-1501-M ELECT 460/3/60 | 700175 | 1 | PC |
| 010 | REFRIGERANT R134A 125LB CYLINDER | 2990135 | 2.8 | LB |
| 010 | J SERIES 1-1.5 TON AIR FILTER ASSY | 700110 | 1 | ASSY |
| 020 | INSULATION PACKAGE B | 457694 | 1 | PC |

* PARTS NOT SHOWN ON DRAWING DETAIL

ALL DIMENSIONS ARE IN INCHES
 THIS PRINT CONTAINS INFORMATION PROPRIETARY TO DIMPLEX THERMAL SOLUTIONS AND MAY NOT BE DUPLICATED, REPRODUCED, OR SHARED IN ANY WAY WITHOUT THE EXPRESSED WRITTEN CONSENT OF DIMPLEX THERMAL SOLUTIONS.

CONFIDENTIAL AND PROPRIETARY

| DATE | DESCRIPTION OF REVISION | APPROVED BY |
|------|-------------------------|-------------|
| | | |
| | | |
| | | |
| | | |
| | | |

| | | |
|---|---------------|---|
|  | |  |
| DESIGN BY: CJS | DRAWN BY: CJS | |
| DATE: 10/14/14 | PAGE 1 OF 1 | KALAMAZOO, MI. PH (800) 968-5665 WWW.DIMPLEXTHERMAL.COM |
| <h3>JHI-1501-M</h3> | | |
| <h2>TABLE OF CONTENTS</h2> | | DRAWING NO. 800251 000 |

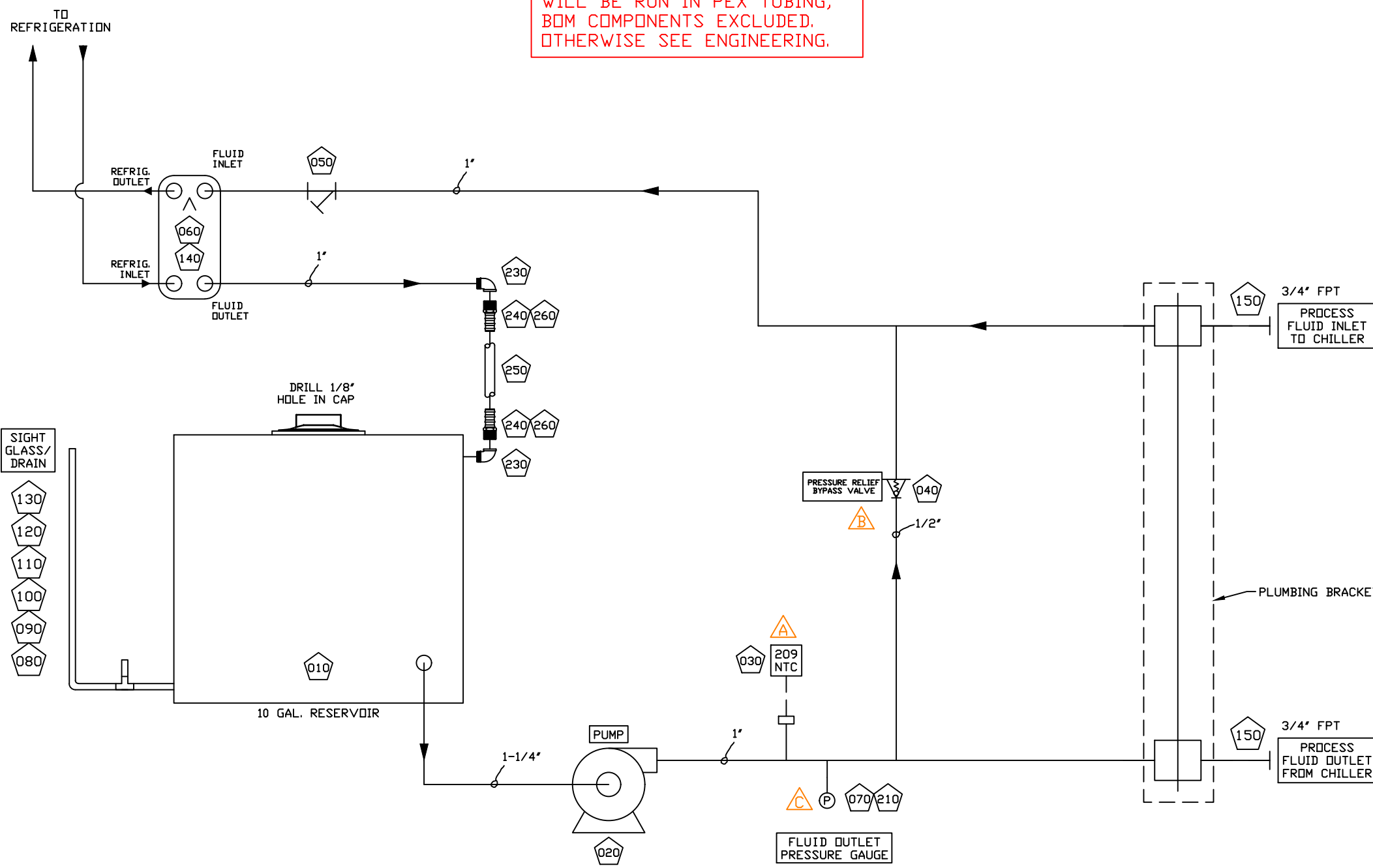

ALL INTERCONNECTING PLUMBING
WILL BE RUN IN PEX TUBING,
BOM COMPONENTS EXCLUDED.
OTHERWISE SEE ENGINEERING.

PIPING PARTS

| NO. | DESCRIPTION | PART# | QTY | TYPE |
|-------|--------------------------------------|----------|-----|------|
| | JH-1501-M PLUMBING | 102120 | | ASSY |
| 010 | TANK PLASTIC 21X16X8 11 GAL | 4514017 | 1 | PC |
| 020 | TPH2T6KS HORIZONTAL PUMP- 3/4 HP | 1785034 | 1 | PC |
| 030 | 1/2 SENSOR ASSY FOR CAREL15' LONG | 611318 | 1 | ASSY |
| 1 | THERMISTOR 15' | 5000161 | 1 | PC |
| 1 | COMPRESSION FITTING 1/2 NPT X 3/16 | 7504920 | 1 | PC |
| 040 | 6815G-1/2-HSS-300 VALVE RELIEF 1/2 | 4183052 | 1 | PC |
| 050 | 1 LF777SI Y-STRAINER FILTER BRONZE | 4353011 | 1 | PC |
| 060 | K070W20C- KTR1 BRAZE PLATE | 2200573 | 1 | PC |
| 070 | GAUGE PIPING CBM 0-160 PSI/BAR | 4246016 | 1 | PC |
| 080 | PC STEM MALE 3/8 DD X 1/4 NPT | 7499018 | 1 | PC |
| 090 | PC TEE - UNION 3/8 DD X 3/8 DD | 7499022 | 1 | PC |
| 100 | PC DOUBLE SEAL 3/8 DD | 7499017 | 2 | PC |
| 110 | HOSE 1/4 CLEAR PVC (VINYL) 1/16 WALL | 4400016 | 3.5 | FT |
| 120 | RED POLYPROPYLENE BALL .1875 DIA | 7802902 | 1 | PC |
| 130 | PC CAP 3/8 DD | 7499019 | 1 | PC |
| 140 | BP INSULATION FOR K070W20 2200501 | 441220 | 1 | ASSY |
| 1 | BP INSULATION FOR K070 FRONT | 441220-1 | 1 | PC |
| 1 | BP INSULATION FOR 2200501 MIDDLE | 441220-2 | 1 | PC |
| 1 | BP INSULATION FOR K070 BACK | 441220-3 | 1 | PC |
| 150 | BUSHING 1 MPT X 3/4 FPT BRS | 7508603 | 2 | PC |
| * 160 | JH 1/8-1.5TDN CASTER & FASTENER ASSY | 703537 | 1 | ASSY |
| 1 | SWIVEL CASTER 3" 125# LOCK | 4503032 | 4 | PC |
| 1 | SCREW 1/4-20 X 5/8 PANHEAD TORX ZINC | 5001299 | 8 | PC |
| 1 | NUT 1/4-20 HEX NYLON INSERT LOCK | 7714012 | 8 | PC |
| 1 | WASHER 1/4 FLAT ZINC | 7715111 | 8 | PC |
| * 200 | TUBE 1 PEX 1-1/8 DD 20' STRAIGHT | 4400027 | 3 | FT |
| 210 | 1/4 HOSE ASSY NF 1/4NPTM X 1/4NPTF | 611482 | 1 | ASSY |
| 1 | HOSEBARB 1/4 MPT X 1/4 HOSE BRS | 7502910 | 1 | PC |
| 1 | HOSE 1/4 ID RED | 4400013 | 3 | FT |
| 1 | 6202052 HOSE CLAMP 7/32 - 5/8 SS | 7797410 | 2 | PC |
| * 220 | HOSEBARB 1/4 X 1/4 FPT BF22 (BRASS) | 7502912 | 1 | PC |
| 1 | FOAM TAPE 3/8" THK X 5/8" WIDE | 5000671 | 0.1 | FT |
| 230 | ELBOW 90 1 MPT X 1 FPT BRS | 7508302 | 2 | PC |
| 240 | HOSEBARB 1 MPT X 1 HOSE BRS | 7508903 | 2 | PC |
| 250 | HOSE 1 RED 300 PSI | 4410002 | 1.5 | FT |
| 260 | 61175 CLAMP HOSE LINED 1" | 7797422 | 2 | PC |

* PARTS NOT SHOWN ON
DRAWING DETAIL



DESIGN BY: CJS DRAWN BY: CJS KALAMAZOO, MI
DATE: 10/16/14 PAGE 1 OF 1 PH (800) 968-5665
WWW.DIMPLEXTHERMAL.COM

**JH-1501-M
PLUMBING**

DRAWING NO.
102120

ALL DIMENSIONS ARE IN INCHES
THIS PRINT CONTAINS INFORMATION PROPRIETARY TO DIMPLEX THERMAL SOLUTIONS AND MAY NOT BE DUPLICATED, REPRODUCED, OR SHARED IN ANY WAY WITHOUT THE EXPRESSED WRITTEN CONSENT OF DIMPLEX THERMAL SOLUTIONS.
CONFIDENTIAL AND PROPRIETARY

| DATE | DESCRIPTION OF REVISION | APPROVED BY |
|----------|-----------------------------------|-------------|
| 1/6/16 | MOVED PRES GAUGE BACK PER REQUEST | AJMKF, 1981 |
| 01/04/16 | CASTER/FASTENER NOW AS ASSEMBLY | JMNKE, 1971 |
| 11/17/15 | CORRECTED OBSOLETE PARTS | AJMKD, 1783 |
| 06/26/15 | P GAUGE WAS AT PUMP OUTLET | CJSC, 0941 |
| 12/15/14 | CORRECTED BYPASS REF & LINE SIZE | CJSC, N/A |
| 10/28/14 | MOVED TEMP SENSOR BEFORE BYPASS | MACA, 6960 |

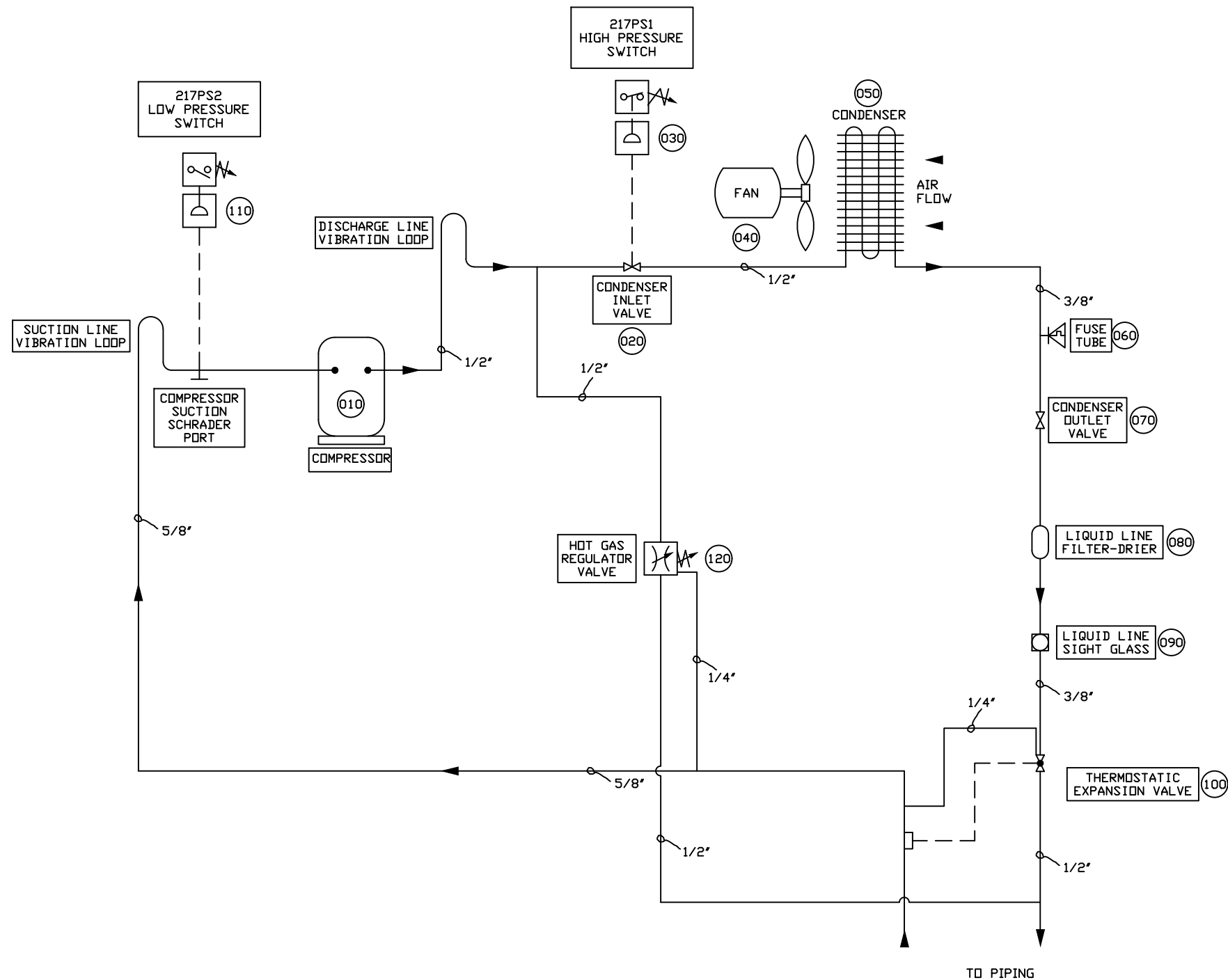

| NO. | DESCRIPTION | PART# | QTY | TYPE |
|-----|-------------------------------------|---------|-----|------|
| | JHI-1500-M REFRIGERATION 460/3/60 | 702005 | | ASSY |
| 010 | COMPRESSOR 1.5 TON 460/3/60 R-134a | 612656 | 1 | ASSY |
| 1 | MTZ32-4 COMPRESS 1.5 TON LF 460/3 | 1442164 | 1 | PC |
| 1 | PTC CRANKCASE HEATER 27 W | 1445001 | 1 | PC |
| 020 | VALVE ANGLE REFRIG 1/2 | 3980001 | 1 | PC |
| 030 | SWITCH HIGH PRESS. 300 MANUAL | 3640018 | 1 | PC |
| 040 | FN-FAN ASSEMBLY - 14" 3PH J SERIES | 612654 | 1 | ASSY |
| 1 | FAN 14" 50/60HZ | 5000271 | 1 | PC |
| 1 | VENTURI 14" 18GA GALV DWG #458750 | 4504152 | 1 | PC |
| 050 | COIL COND JH 20"FH x 18"FL | 1413500 | 1 | PC |
| 060 | FUSE TUBE COPPER/SOLDER | 7399201 | 1 | PC |
| 070 | VALVE ANGLE REFRIG 3/8 | 3980000 | 1 | PC |
| 080 | C-053S FILTER DRIER 3/8" | 2730002 | 1 | PC |
| 090 | SA-13S SIGHT GLASS 3/8 ODF (R146-1) | 2720002 | 1 | PC |
| 100 | EBF JE-B-CP60 VALVE EXPANSION R134A | 2760078 | 1 | PC |
| 110 | LDV PRESSURE SWITCH 10/20 | 3640006 | 1 | PC |
| 120 | ADRSE-2 VALVE DISCHARGE BYPASS 1/2 | 2740001 | 1 | PC |
| 130 | JHI-1500 PRE-BENT KIT | 703061 | 1 | PC |

* PARTS NOT SHOWN ON DRAWING DETAIL

ALL DIMENSIONS ARE IN INCHES

THIS PRINT CONTAINS INFORMATION PROPRIETARY TO DIMPLEX THERMAL SOLUTIONS AND MAY NOT BE DUPLICATED, REPRODUCED, OR SHARED IN ANY WAY WITHOUT THE EXPRESSED WRITTEN CONSENT OF DIMPLEX THERMAL SOLUTIONS.

CONFIDENTIAL AND PROPRIETARY

| DATE | DESCRIPTION OF REVISION | APPROVED BY |
|----------|-----------------------------|--------------|
| 11/30/15 | ADDED PRE-BENT KIT | CJS<C, 1830> |
| 9/17/15 | UPDATED BOM | CM<B, 1454> |
| 5/8/15 | MADE FROM 101731 AND 612671 | JMKA, 006072 |

DESIGN BY: CJS
DATE: 08/28/14

DRAWN BY: CJS
PAGE 1 OF 2

KALAMAZOO, MI
PH (800) 968-5665
WWW.DIMPLEXTHERMAL.COM

JHI-1500 460/3/60

REFRIGERATION

DRAWING NO.
702005

TAG TO ES-002 STANDARD

WIRE TO SBP-WIRESTD

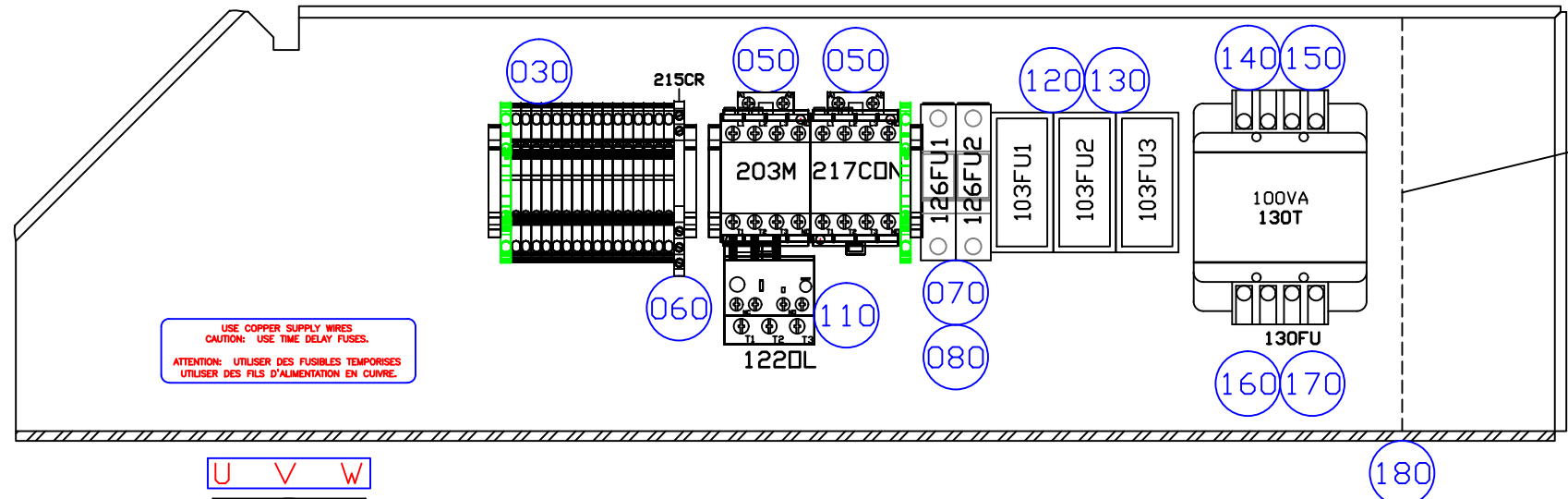

USE COPPER SUPPLY WIRES
CAUTION: USE TIME DELAY FUSES.
ATTENTION: UTILISER DES FUSIBLES TEMPORISES
UTILISER DES FILS D'ALIMENTATION EN CUIVRE.

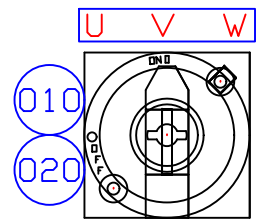

CAUTION: DISCONNECT THE REMOTE
ELECTRIC POWER SUPPLY OR
SUPPLIES BEFORE SERVICING.

TEMPERATURE ADJUSTMENT
1. HOLD SW UNTIL TEST APPEARS
2. USE A #2 TORX TO ADJUST TEMP. SET POINT.
3. PRESS SW TO SAVE.

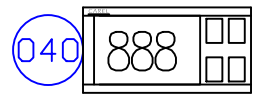

NRTL LISTED COMPLIES WITH
UL 1995
LISTING # KDD1995

Dimplex Thermal Solutions
2625 Emerald Drive
Kalamazoo, Michigan 49001-4542
Phone: (269) 349-6800 Fax: 349-8951
Model: JHI-1501-M
Serial:

| 480 VOLT-3 PHASE-60Hz | | | |
|-----------------------|--------|-----------|-----------|
| | H.P. | FLA(Amps) | LRA(Amps) |
| 1 Compressor | 1.5 | 6.7 | 25 |
| 1 Pump | 3/4 | 2.1 | |
| 1 Fan | 0.30KW | 0.46 | |

Minimum Circuit Ampacity: 10 Amps
Maximum Overcurrent Protection: 20 Amps
SCCR: 5KA

REFRIGERATION
Refrigerant: R-134a
Pounds: 2.8 Lbs
Design Pressure
High Side: 200 PSI Low Side: 55 PSI
Manufactured:
Indoor Use

WARNING: RISK OF ELECTRICAL SHOCK. CAN CAUSE
INJURY OR DEATH. DISCONNECT ALL REMOTE
ELECTRICAL POWER SUPPLIES BEFORE SERVICING.

DRAWINGS
700175 (1-3)

REPLACE ONLY WITH
TIME DELAY FUSES

| | | |
|----------|------|------|
| 103FU1-3 | 15A | 600V |
| 126FU1-2 | 0.6A | 600V |
| 130FU | 1A | 250V |

* NOTE: TERMINAL
CONNECTORS MOUNTED
ON INTERNAL BRACKET

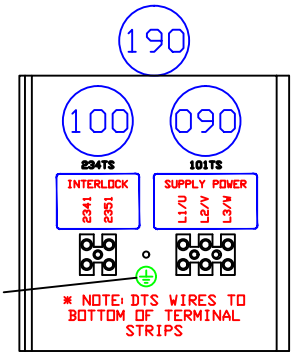

* NOTE: USE 10/32
GROUND STUD

* NOTE: DTS WIRES TO
BOTTOM OF TERMINAL
STRIPS

CAUTION: DISCONNECT THE REMOTE
ELECTRIC POWER SUPPLY OR
SUPPLIES BEFORE SERVICING.

* NOTE: PLACE BELOW
THE ACCESS COVER

* PARTS NOT SHOWN ON
DRAWING DETAIL

| NO. | DESCRIPTION | PART# | QTY | TYPE |
|-----|-------------------------------------|---------|-----|------|
| 010 | JHI-1501-M ELECT 460/3/60 | 700175 | | ASSY |
| 020 | 194E-E32-1753 DISCONNECT 32A | 3110051 | 1 | PC |
| 030 | 194L-HC6N-175 DISCONNECT HANDLE | 3110050 | 1 | PC |
| | 10 TEC TERMINAL BLOCKS A-B 1492-LQ3 | 606532 | 1 | ASSY |
| 1 | 1492-L30 TERMINAL BLOCK (20 AMP) | 3123021 | 11 | PC |
| 1 | 1492-EBL30 END BARRIER (20 AMP) | 3123086 | 1 | PC |
| 1 | 1492-ERL35 END ANCHOR (20/50 AMP) | 3123087 | 4 | PC |
| 1 | 1492-LG30 GROUNDING BLOCK (20 AMP) | 3123017 | 1 | PC |
| 1 | 1492-CJK510 JUMPER (20 AMP) | 3123095 | 0.1 | PC |
| 1 | 199-DR1 MOUNTING RAIL | 3127100 | 1.5 | PC |
| 040 | IR33E7HR20 CONTROLLER CAREL | 4807822 | 1 | PC |
| 050 | 100-C09D10 CONTACTOR 120VAC CDIL | 3100200 | 2 | PC |
| 060 | 700-HLT1U1 RELAY 120V AC/DC | 3159103 | 1 | PC |
| 070 | CHCC1D FUSE HOLDER 30A CC CLASS | 3511203 | 2 | PC |
| 080 | FUSE ATDR-6/10 DR FNQR-6/10 | 3500983 | 2 | PC |
| 090 | 39100-2203 TERMINAL BLOCK MOLEX | 3899570 | 1 | PC |
| 100 | 39100-1902 TERMINAL BLOCK MOLEX | 3899569 | 1 | PC |
| 110 | 193-EDICB RELAY 1 - 5 AMP | 3103504 | 1 | PC |
| 120 | JT60030 SINGLE 30 AMP FUSE HOLDER | 3511502 | 3 | PC |
| 130 | AJT15 DR LPJ15 FUSE | 3500909 | 3 | PC |
| 140 | E100 TRANSFORMER 100VA | 3842164 | 1 | PC |
| 150 | TP20 TOUCH SAFE COVERS HEVI | 3899019 | 1 | PC |
| 160 | FBXC SECONDARY TERMINAL COVER | 3899018 | 1 | PC |
| 170 | TRM1 DR FNMI FUSE | 3500010 | 1 | PC |
| 180 | BRKT EBOX 21.31X5.75X10 12GA GALV | 458836 | 1 | PC |
| 190 | BRKT TERMINAL 21.31X5.75X10 12GA | 458797 | 1 | PC |
| 200 | 9600K47 GROMET 3/8"X7/8"X1/8" MAT'L | 7739580 | 1 | PC |

ALL DIMENSIONS ARE IN INCHES

THIS PRINT CONTAINS INFORMATION PROPRIETARY
TO DIMPLEX THERMAL SOLUTIONS AND MAY NOT BE
DUPLICATED, REPRODUCED, OR SHARED IN ANY WAY
WITHOUT THE EXPRESSED WRITTEN CONSENT OF
DIMPLEX THERMAL SOLUTIONS.

CONFIDENTIAL AND PROPRIETARY

| DATE | DESCRIPTION OF REVISION | APPROVED BY |
|--------|-------------------------|-------------|
| 1/6/16 | ADDED IR33 TEMP TAG | JMNCB, 1991 |



DESIGN BY: KC DRAWN BY: KC
DATE: 10/14/14 PAGE 3 OF 3
KALAMAZOO, MI
PH (800) 968-5665
WWW.DIMPLEXTHERMAL.COM

JHI-1501-M

ELECTRICAL

DRAWING NO.
700175-3

460V / 3PH / 60HZ

8.6 FLA

* NOTE: APPLY ORANGE TAPE ON BOTH WIRE ENDS FOR L1, L2, & L3

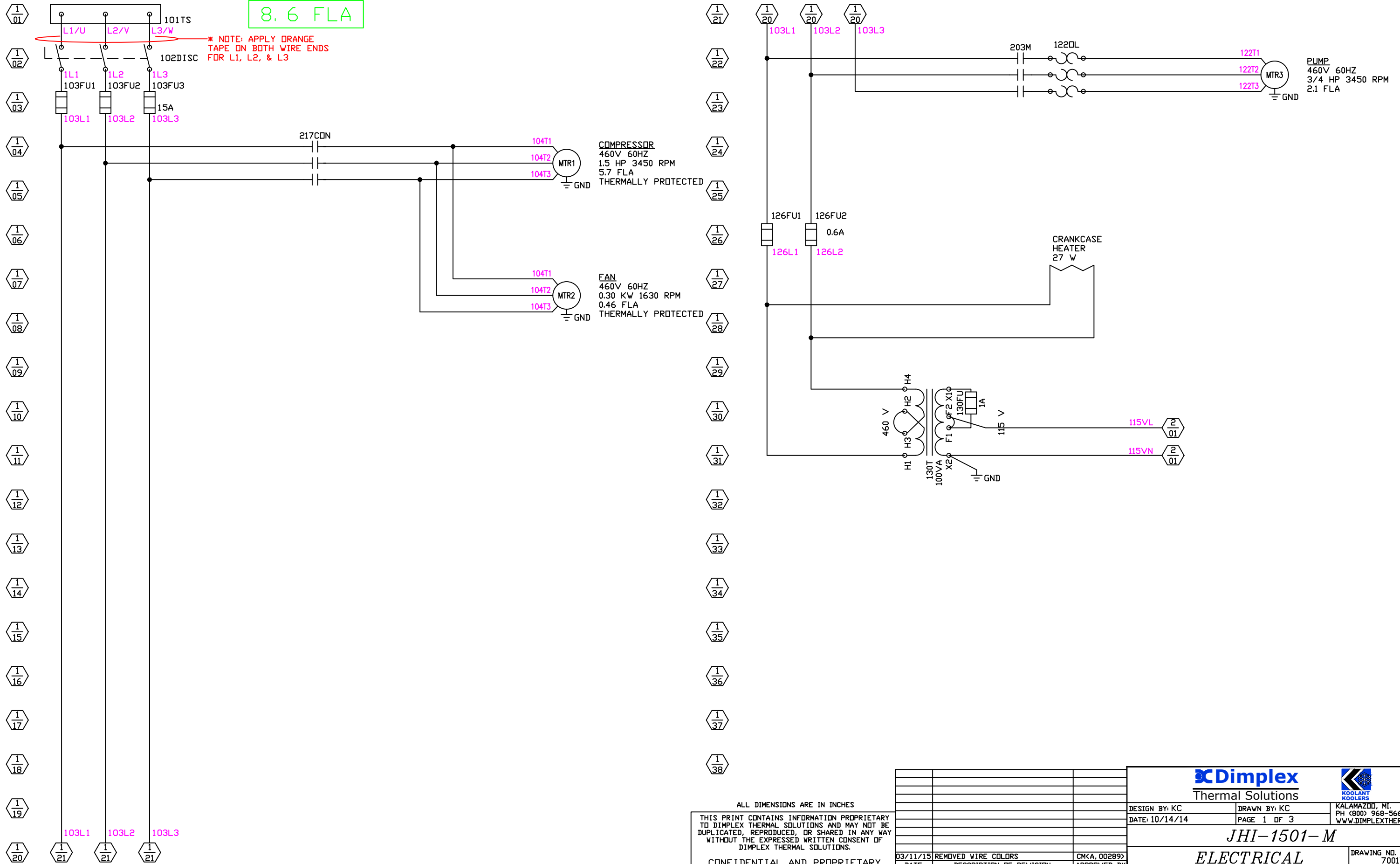

ALL DIMENSIONS ARE IN INCHES
 THIS PRINT CONTAINS INFORMATION PROPRIETARY TO DIMPLEX THERMAL SOLUTIONS AND MAY NOT BE DUPLICATED, REPRODUCED, OR SHARED IN ANY WAY WITHOUT THE EXPRESSED WRITTEN CONSENT OF DIMPLEX THERMAL SOLUTIONS.
 CONFIDENTIAL AND PROPRIETARY

| | | |
|----------|-------------------------|--------------|
| 03/11/15 | REMOVED WIRE COLORS | CMKA, 002899 |
| DATE | DESCRIPTION OF REVISION | APPROVED BY |

| | | |
|-------------------------------------|--------------|---|
| Dimplex Thermal Solutions | | |
| DESIGN BY: KC | DRAWN BY: KC | KALAMAZOO, MI |
| DATE: 10/14/14 | PAGE 1 OF 3 | PH (800) 968-5665 WWW.DIMPLEXTHERMAL.COM |
| JHI-1501-M | | |
| ELECTRICAL | | DRAWING NO. 700175-1 |

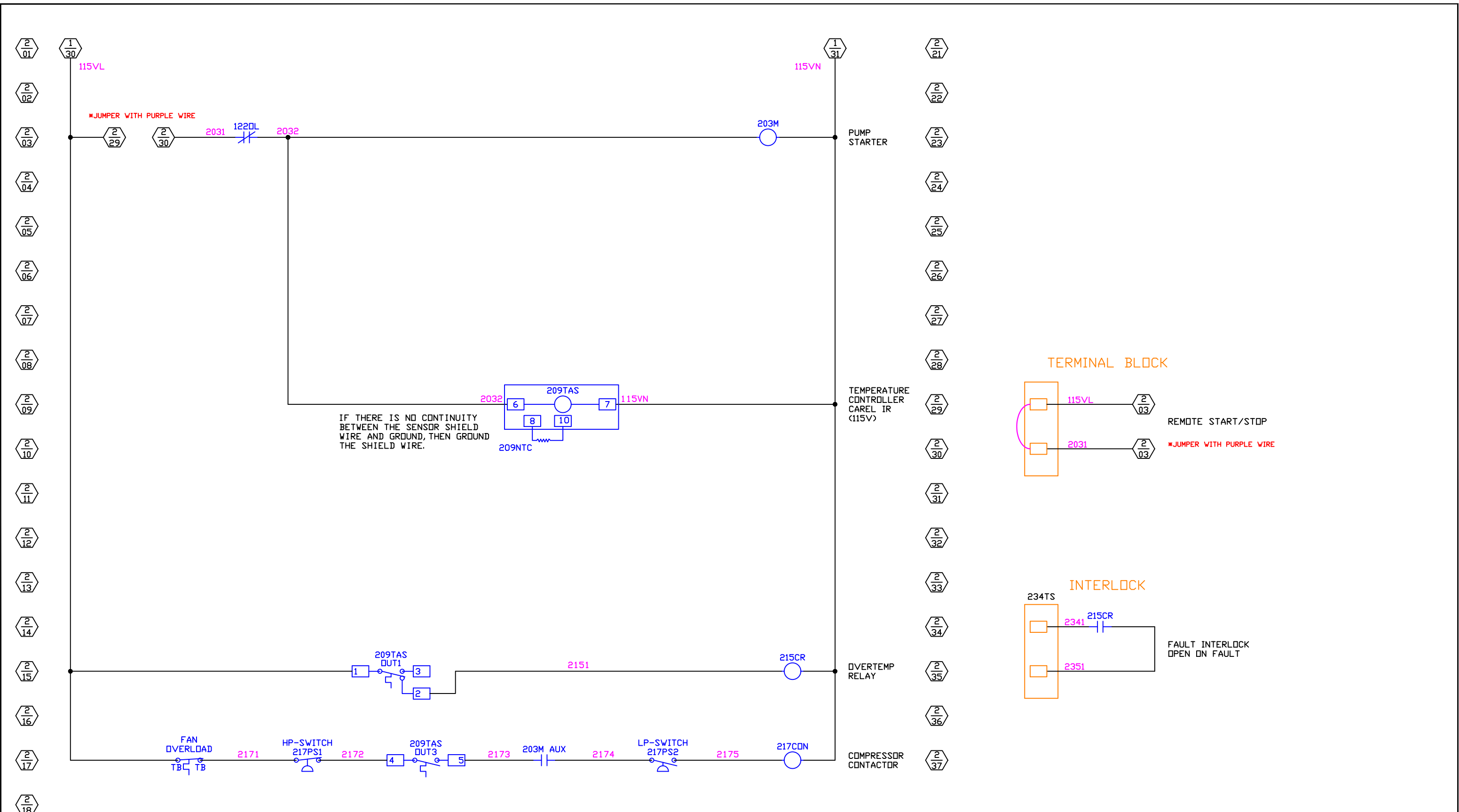

2/01
2/02
2/03
2/04
2/05
2/06
2/07
2/08
2/09
2/10
2/11
2/12
2/13
2/14
2/15
2/16
2/17
2/18
2/19
2/20

1/31
2/21
2/22
2/23
2/24
2/25
2/26
2/27
2/28
2/29
2/30
2/31
2/32
2/33
2/34
2/35
2/36
2/37

ALL DIMENSIONS ARE IN INCHES

THIS PRINT CONTAINS INFORMATION PROPRIETARY TO DIMPLEX THERMAL SOLUTIONS AND MAY NOT BE DUPLICATED, REPRODUCED, OR SHARED IN ANY WAY WITHOUT THE EXPRESSED WRITTEN CONSENT OF DIMPLEX THERMAL SOLUTIONS.

CONFIDENTIAL AND PROPRIETARY

| DATE | DESCRIPTION OF REVISION | APPROVED BY |
|----------|--------------------------------|--------------|
| 9/1/15 | CHANGED GROUND NOTE FOR SENSOR | CM<B, 1347> |
| 03/11/15 | REMOVED WIRE COLORS | CM<A, 00289> |

Dimplex
Thermal Solutions

Koolant
Koolants

DESIGN BY: KC
DATE: 10/14/14

DRAWN BY: KC
PAGE 2 OF 3

KALAMAZOO, MI
PH (800) 968-5665
WWW.DIMPLEXTHERMAL.COM

JHI-1501-M

ELECTRICAL

DRAWING NO.
700175-2